

Development of Methodologies for the Testing and Evaluation of Solar Lanterns

by

Amit A. Gandhi

B.S. Mechanical Engineering

California Institute of Technology, 2009

SUBMITTED TO THE DEPARTMENT OF MECHANICAL ENGINEERING IN PARTIAL FULFILLMENT OF THE REQUIREMENTS FOR THE DEGREE OF

MASTER OF SCIENCE IN MECHANICAL ENGINEERING
AT THE
MASSACHUSETTS INSTITUTE OF TECHNOLOGY
FEBRUARY 2014

ARCHIVES

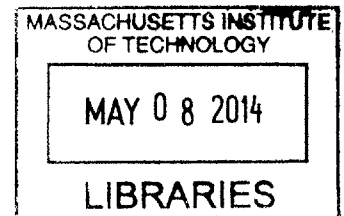

© Amit A. Gandhi, MMXIII. All rights reserved.

The author hereby grants to MIT permission to reproduce and to distribute publicly paper and electronic copies of this thesis document in whole or in part in any medium now known or hereafter created.

Author _____
Department of Mechanical Engineering
September 30, 2013

Certified by _____
Timothy G. Gutowski
Professor of Mechanical Engineering
Thesis Supervisor

Accepted by _____
David E. Hardt
Chairman, Department Committee on Graduate Students

Development of Methodologies for the Testing and Evaluation of Solar Lanterns

by

Amit A. Gandhi

Submitted to the Department of Mechanical Engineering
on September 30, 2013 in Partial Fulfillment of the
Requirements for the Degree of Master of Science in
Mechanical Engineering

ABSTRACT

Solar lighting technologies have reached a point where they are affordable in many developing countries. While many of these products have had a positive impact on communities, the market also has poorly designed and manufactured products that develop a poor reputation among users and hurt adoption rates of solar technologies. Current efforts to evaluate solar lanterns have resulted in the development of standards and testing protocols for solar lanterns manufacturers. In this thesis, we explored the development of new user-focused testing methodologies that include both field testing and technical testing. In particular, for the field testing, we applied projective methods to understand biases in reported usage, addressed individual decision making process, and applied maximum difference methodology to understand user-valuation. For the technical testing, we developed a new system for characterizing the light output of solar lanterns and developed embedded instrumentation for solar lanterns to understand how they were used in the field.

Thesis Supervisor: Timothy G. Gutowski

Title: Professor of Mechanical Engineering

Acknowledgements

I would like to first acknowledge USAID, the CITE program, and the PEGS Fellowship for their financial support in helping me to conduct this research.

Further, I would like to thank my advisor, Timothy Gutowski, for his feedback and support through the project. I would also like to thank Amy Smith and Derek Brine for helping to guide me towards this research topic and providing support along the way.

D-Lab played a significant role in shaping this thesis and allowing it to happen and I would like to thank everyone I have worked with over the past few years for the inspiration and opportunities. I would like to thank Kendra Leith for providing guidance on the development of the field methodology and insight into the intricacies of conducting field work. I would like to thank Amelia Carver for accompanying me to Ghana to conduct field research. I would also like to thank Victor Lesniewski and Christopher Pombrol for their long hours and insightful discussions spent preparing for the Uganda study. Finally, I would like to thank Jessica Huang for her help throughout my research and with her help editing my thesis and Jack Whipple for his help and positivity whenever we needed to fabricate something for our project.

I would like to thank Dr. Jeff Asher and Dr. Dan Frey for the provoking conversations in the development of the last part of the study and for their support and encouragement. I learned a great deal through those conversations.

Contents

Chapter 1.....	12
1.1 Background	12
1.2 Approach.....	13
1.3 Solar Lanterns for the Study	14
Chapter 2.....	15
2.1 Stage I Pilot	15
2.1.1 Community and User Profiles	15
2.1.2 Procedure.....	17
2.1.3 Conclusions	19
2.2 Stage II Ghana	19
2.2.1 Community and User Profile.....	19
2.2.2 Procedure.....	20
2.3 Stage III Uganda	23
2.2.1 Community Profile	23
2.2.2 Procedure.....	25
Chapter 3.....	27
3.1 Projective Methods – modified ZMET Analysis	27
3.2 Decision Making Process.....	29
3.3 Solar Lantern Usage	32
3.3.1 Usage in Ghana	32
3.3.2 Usage in Uganda	33
3.4 Maximum Difference Analysis	34
Chapter 4.....	37
4.1 Measuring Brightness	37
4.2 Spectral Measurements.....	40
4.3 Measurement System.....	40
4.4 Photodiode Layout.....	42
4.5 Calibration.....	44
4.6 Measurement & Results	45

Chapter 5.....47

- 5.1 Design of the system.....47
 - 5.1.1 Selection of Components.....48
 - 5.1.2 Design of PCB49
 - 5.1.3 Operation Mode Characterization49
 - 5.1.4 Accelerometer Measurements50
- 5.2 Integration into Solar Lantern.....52
 - 5.2.1 Fabricating the Chip52
 - 5.2.2 Installing the Chip52
 - 5.2.3 Starting Acquisition.....53
 - 5.2.4 Retrieving Data.....54
- 5.3 Results.....55

Chapter 6.....58

Appendix A – Surveys.....59

List of Figures and Tables

Figure 1: Solar Lantern Models. From left to right: Firefly, Kiran and Mini BoGo.....	14
Figure 2: Field Protocol for Stage 1 Pilot Study	17
Figure 3: Age and Gender Distributions for the Stage II Ghana Study.....	20
Figure 4: Field Protocol for Stage II Solar Light Users	21
Figure 5: Field Protocol for Stage II New Participants	22
Figure 6: Map of the Regional Stratification for the Stage III Study	24
Figure 7: Age and Gender Distributions for Stage III Subjects.....	24
Figure 8: Field Protocol for Stage III Solar Lantern Users	25
Figure 9: Model of the Decision-Making Process	29
Figure 10: Histogram of Distance Traveled to Purchase Last Light.....	31
Figure 11: Solar Lantern Usage Distribution in Ghana.....	32
Figure 12: Solar Lantern Usage Distribution in Uganda.....	33
Figure 13: Standard Scores for Different Attributes of Solar Lighting from Stage II Ghana	35
Figure 14: Standard Scores for Different Attributes of Solar Lighting from Stage III Uganda	36
Figure 15: Diagram of the Measurement of a Closed Surface with a Representative Area	39
Figure 16: Normalized Spectra for the DLight and Firefly lights plotted with Luminosity Function	40
Figure 17: Circuit Diagram for the Photodiode – OpAmp – Multiplexer System	41
Figure 18: Photodiode Layout.....	42
Figure 19: Photodiode Board Layout and Schematic.....	43
Figure 20: Assembled LightBox.....	43
Figure 21: Sample Calibration Curve for a Photodiode	44
Figure 22: Light Output Diagrams from LightBox	46
Figure 23: Overall System Architecture	47
Figure 24: PCB Designed for Instrumentation System.....	49
Figure 25: Circuit Diagram for Current Measurement System	49
Figure 26: Sample Usage Frame for D-Light (left) and Firefly (right).....	50
Figure 27: Sample Acceleration Profile for a D-Light.....	51
Figure 28: Completed Instrumentation Board.....	52
Figure 29: Solar Lanterns with Instrumentation Installed. Left: Firefly. Right: D-Light.	53

Figure 30: Solar Lanterns with Instrumentation Embedded. Left: Instrumented Lanterns. Right: Normal Lanterns. 54

Figure 31: Histograms of Usage Error. Top: Firefly. Bottom: D-Light. 57

Table 1: Strengths and Weaknesses of Follow-up Locations 19

Table 2: Field Methodologies Developed for Different Stages..... 27

Table 3: Design of the Max-Diff Survey 34

Table 4: Voltage Differences and Corresponding Usage States..... 50

Table 5: Percentage Error in Average Usage 55

Table 6: Individual Errors in Reported Usage for Each User 56

Chapter 1

Introduction

1.1 Background

The solar lighting market has been rapidly growing in developing countries. With the recent availability of cheap white LED light sources and the decreasing price solar panels, consumers are able to purchase personal solar lighting systems that cost between \$10 and \$100. However, in recent years, the market for WLED lanterns has been flooded with a number of technologies, many of them poorly designed and manufactured. As with other technologies in developing countries, introducing sub-par technologies adversely impacts the rate at which technologies are adopted. For example, in Kenya, the prevalence of low-quality brands has drastically reduced consumer confidence and hindered sales for over a decade (1). Several testing agencies, such as Lighting Africa and the Lumina Project, have begun evaluating the impact and quality of solar lighting technologies and are calling for independent testing of solar technologies to address the varying levels of lantern quality compared to claims.

The primary goal of this thesis is to establish a framework for the evaluation of solar lighting technologies by assessing their quality and usability. The study consists of two broad components, the development of field methodology for understanding the usage and valuation of the products in the field and the development of laboratory methodology for technical testing and solar lantern performance characterization.

There are two major solar lighting testing organizations that have provided much of the framework for the testing of solar lanterns. The Lumina Project is an initiative from the U.S. Department of Energy's Lawrence Berkeley National Laboratory. The goals of the Lumina Project are to provide "industry, consumers, and policymakers with timely analysis and information on off-grid lighting solutions for the developing world." (2) Lighting Africa is a joint IFC and World Bank initiative looking at developing the commercial market for off-grid lighting

in Sub-Saharan Africa. Lighting Africa provides both technical testing of solar lanterns and market analysis of products to promote solar lighting technologies.

1.2 Approach

The overall approach to the development of methodologies for the evaluation of solar lanterns was to couple laboratory testing results with usage information from an intensive field study. This thesis looks to draw upon the methodologies and results developed by Lighting Africa, the Lumina Project, and other testing organizations.

Chapters 2-3 focus on field methodologies. Chapter 2 provides an overview of the fieldwork carried out in this study, presenting the overall scope, community information, and field protocols carried out.

Chapter 3 focuses on the development and application of different field methodologies to solar lantern evaluation. Four distinct methods are explored, a projective method to provide cultural context, an assessment to understand individual decision-making processes, a survey to capture solar lantern usage information, and the application of a maximum difference analysis to understand user valuation of characteristics of light.

Chapter 4 focuses on technical testing. We present a novel, low-cost device for the characterization of light output from a solar lantern that functionally corresponds to the recently developed IEC standards. The chapter focuses on the design of the lightbox and presentation of the results from measurements taken with the device.

Chapter 5 focuses on the development of field instrumentation. We explore the opportunity to assess usage patterns in the field through the use of embedded instrumentation and present a design for an instrumentation system. The chapter also examines the issue of unreliable reporting in field studies by comparing results from the field instrumentation with user-reported usage.

Chapter 6 provides a conclusion for the study and addresses future work.

1.3 Solar Lanterns for the Study

We elected to use three different solar lanterns in the development of the methodologies: the Barefoot Power Firefly, the D-Light Kiran, and the SunNight Solar Mini BoGo as shown in Figure 1.

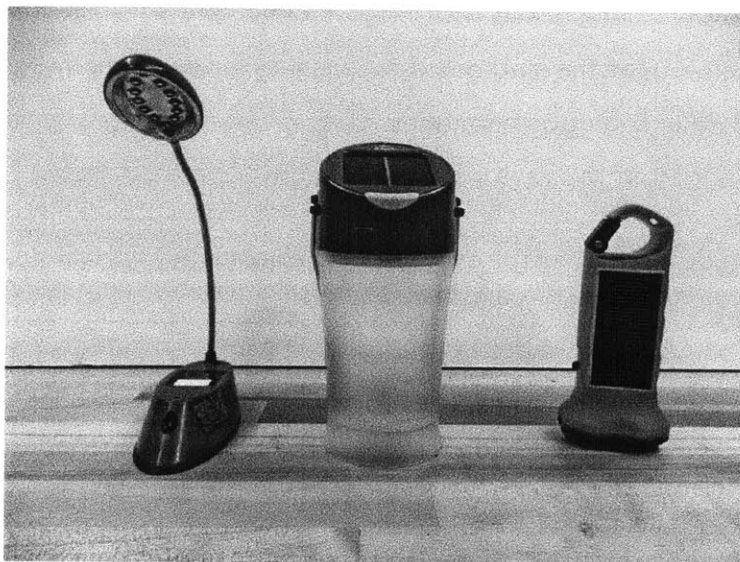

Figure 1: Solar Lantern Models. From left to right: Firefly, Kiran and Mini BoGo.

The three solar lanterns chosen for the study each represent one of the types of personal solar lighting systems available for individuals. The Firefly is a task light manufactured by Barefoot Power. The primary advantages of task lights are that they are portable, easy to handle and use, and provide a bright light applicable for many tasks. Primary disadvantages are that they generally have an unfamiliar design, are fragile, and provide directional light. The Kiran (S10) is a lantern manufactured by D-Light. The primary advantages of lantern designs are that they are easy to use, familiar, portable, and convenient. Primary disadvantages are that they provide inadequate light for large areas and have a lower battery life. Finally, the Mini BoGo is a torchlight/flashlight manufactured by SunNight Solar. Torchlights are easy to maintain, reliable and familiar. The primary disadvantages of torchlights are that they are not practical for household illumination. (3)

Chapter 2

Fieldwork Methodology

The field research for this study was conducted to understand usage of solar lighting technologies in developing countries. The study was divided into three distinct stages: The first stage was a pilot study carried out in various countries to establish user context and to determine future direction. The second stage was an in-depth follow-up study on usage patterns in rural Ghana focused at understanding user valuation of lighting. The third stage was a study of solar lighting users in Uganda.

2.1 Stage I Pilot

The aims of the initial stage of field-testing were primarily to understand the local context in which the study would be conducted and choose an appropriate location to administer a follow-up study. To achieve this, we developed an open-ended, semi-structured interview tool to meet the following goals.

- 1) Understand user valuation of different lighting technologies
- 2) Understand the cultural/socio-economic context of the communities
- 3) Identify which qualities of lighting were important to users

Through the D-Lab Development Course, we were able to pilot the survey with trained student teams that were already traveling on field trips to Ghana, Zambia, Brazil, and Cambodia in January 2012.

2.1.1 Community and User Profiles

The pilot study focused on small communities of four distinct geographic regions, the villages of Dwere and Gomboi in the Brong-Ahafo region in mid-western Ghana, Kandal Kraom in the Kandal Province in southern Cambodia, Jardim Santo Antonio the Sao Paulo state in Brazil, and

Linda Compound in the Lusaka District in Zambia. Of the four countries, Cambodia and Ghana showed the most promise for follow-up fieldwork.

Kandal Kraom

Kandal Kraom is located in the Banteay Daek commune of the Kandal Province in Cambodia. In this region, the surveys were conducted in small on- and off- grid villages surrounding the Kandal Kraom village hub, with fewer than 100 households each. The Banteay Daek commune has a population of 14,593 (7,441 female, 7,152 male) as of 2008 (4). While exact population data on the Kandal Kraom is unavailable map estimates approximate the population of the region as somewhere between 3,000-5,000.

Dwere and Gomboi

Dwere and Gomboi are two off-grid villages located in the Kintampo District of the Brong-Ahafo region of Ghana. While documented population data for the villages is unavailable, the villages have an estimated population of 200 based on community surveys. Population statistics from the 2010 Ghana census indicate the encompassing Kintampo North District has a population of 95,480 (47,302 male, 48,178 female) (5).

2.1.2 Procedure

The procedure for the study is shown in Figure 2:

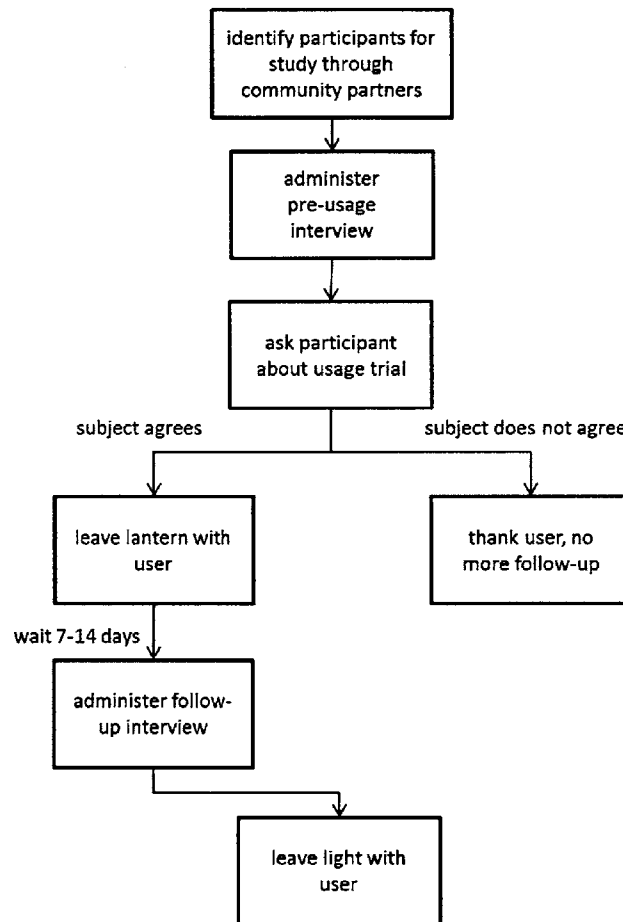

Figure 2: Field Protocol for Stage 1 Pilot Study

Identify a sample of subjects

Participants in the study were selected to representatively match the age and gender demographics of the region; however, the sample selection could not be fully randomized. This was primarily due to the limitations in time available for interviewing and the availability of community partners and subjects in the trials. Given the short duration of the study, a randomized trial could not be constructed and only subjects who were available and willing to be interviewed participated in the study. While the specifics of this selection process varied

based on the region, it is important that a selection bias was noted in the analysis of the resulting data.

Administer a pre-usage interview

Participants in the study were administered a 30 minute pre-usage interview aimed primarily at establishing background information the user's existing lighting situation. The questions were developed to provide a contextual basis from which to compare the solar lighting technologies that would be provided to the users and to understand the use of these newly introduced lighting sources.

Leave a lantern with the subject for user-testing

Following the initial interview, users were left with one of the three solar lighting technologies for product testing and informed that there would be a follow-up interview about the lights administered between 7 and 14 days after the initial interview.

Administer a follow-up interview

Following the trial period, participants were re-interviewed for approximately 30 minutes to understand their usage of the lanterns. The follow-up questions were aimed primarily at understanding how much the users valued the lights and which aspects of the lights they valued. The follow-up interview was administered as a semi-structured interview with open-ended questions to allow users to express themselves freely and no quantitative measurements were made at this stage.

End of Study

At the conclusion of the study, the users were informed that they would be allowed to retain the solar lanterns if they agreed to participate in a potential follow-up study that would take place within the next year. Contact information for the individuals was collected for follow-up purposes and kept separate from the results.

2.1.3 Conclusions

	Brazil	Cambodia	Ghana	Zambia
Strength of community partners	0	0	+	+
User-interest in technology	0	+	+	0
Community size	0	-	-	-
Accessibility	0	-	-	0
Potential for follow-up	0	0	+	+
Exposure to solar technologies	0	0	+	+

Table 1: Strengths and Weaknesses of Follow-up Locations

Based on the results of the first survey, we chose Ghana as our region of focus primarily due to the interest in solar lighting technologies from the community, our ability to follow-up with the community, and the strength of our field partners there. By processing the initial data we also learned that we needed to develop more quantitative tools to enable a ranking methodology.

2.2 Stage II Ghana

Based on the results of the pilot study, we developed a more focused secondary study to assess the user valuation of lighting technologies. This second stage of field testing occurred in August 2012 and consisted of several different components aimed at understanding user behavior around lighting. The secondary stage of the study was conducted in the Brong-Ahafo region of the Ghana and consisted of three types of follow-up interviews, a full length semi-structured interview for follow-up with subjects who had been using solar lighting technologies (SOLAR LIGHT USERS n=10), a full-length semi-structured interview for new subjects (NEW PARTICIPANTS n = 17), and a shorter interview consisting of best-worst scaling questions for new subjects with limited time (MAX-DIFF ONLY n = 8).

2.2.1 Community and User Profile

The region of interest for the Stage 2 study was four communities in the Brong-Ahafo region where the pilot study took place. Three of the four communities were in the Kintampo North District and included Dwere, Gomboi (see 2.1.1) and the larger village of New Longoro, with an approximate population of 2,000 based on community partner estimates. The fourth community was the Subingya village, an off-grid village in the Wenchi Municipal District. The villages are located in separate districts, located within 50 km of each other.

Figure 3 demonstrates the age distribution of the subjects in the study.

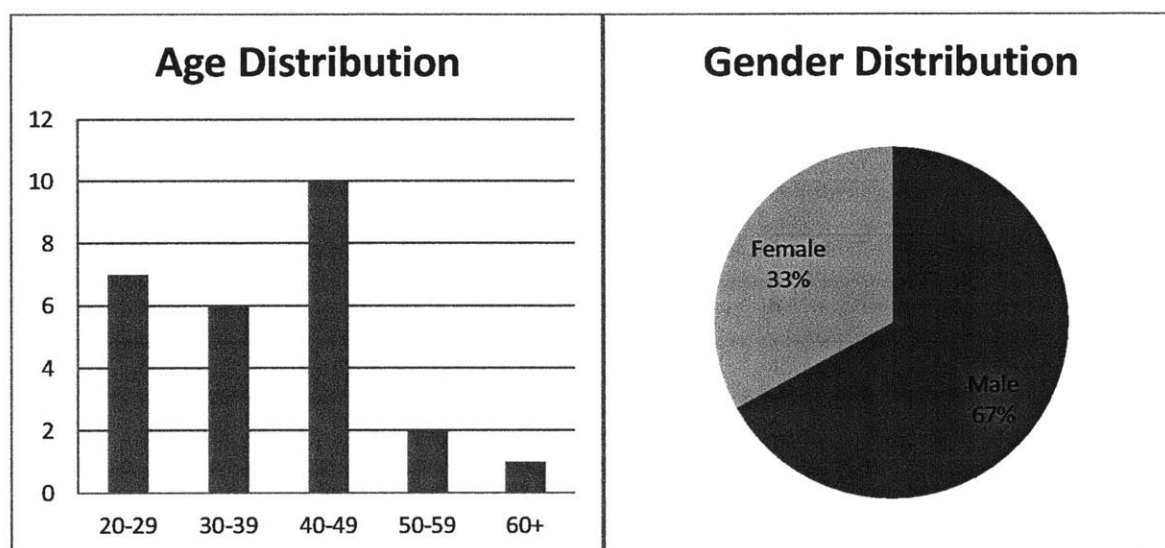

Figure 3: Age and Gender Distributions for the Stage II Ghana Study

2.2.2 Procedure

The procedure for the Stage II study consisted of conducting interviews in two parallel tracks with two different goals. The first was to follow-up with participants from the Stage 1 study and understand how they had been using their solar lanterns, as shown in Figure 4. The second was to assess community lighting usage by interviewing new subjects about their valuation of different characteristics of lighting. Two surveys were designed for new subjects: a longer survey for new participants who were willing and able to be interviewed for a longer period and a shorter survey for new subjects who were unable to commit a longer length of time for an interview, as shown in Figure 5.

SOLAR LIGHT USERS PROTOCOL

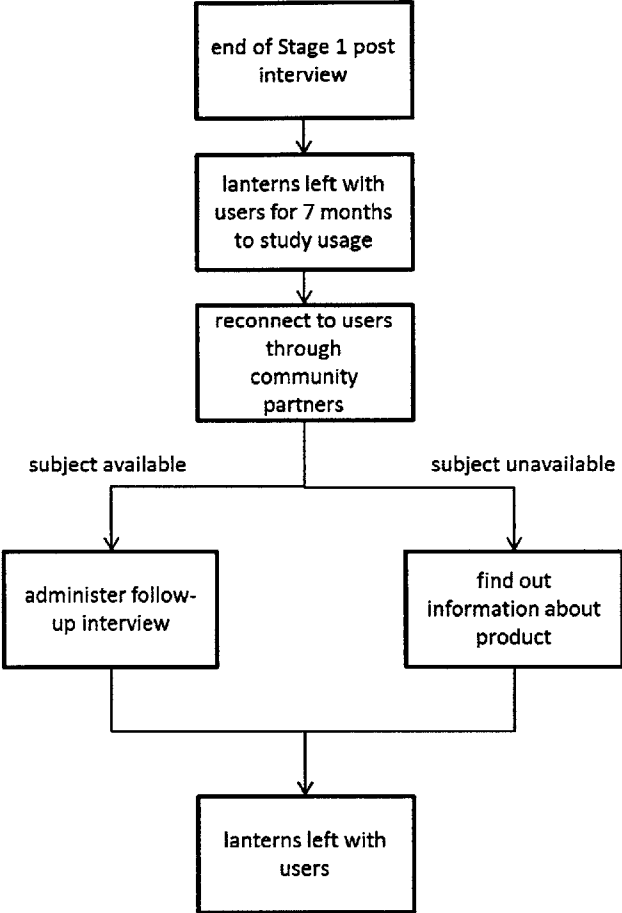

Figure 4: Field Protocol for Stage II Solar Light Users

Administer follow-up interview

The solar light user protocol consisted of reconnecting with users who had participated in the Stage 1 January field study. These users had been left with the trial solar lanterns for usage between January and August and were notified that they would be interviewed through community contacts. For subjects that were available, we conducted a 1 hour semi-structured interview for follow-up (APPENDIX) that asked questions to assess the functionality of their solar lantern, to understand how they were using their solar lantern and how it displaced other lighting options for the user, and finally to rate the functionality of the light through a scale. We also requested that the subjects allow us to observe them using their solar lanterns in the

community following the interview. For subjects that were unavailable for follow-up interviewing, we attempted to find out information about the functionality of their product.

NEW PARTICIPANT PROTOCOL

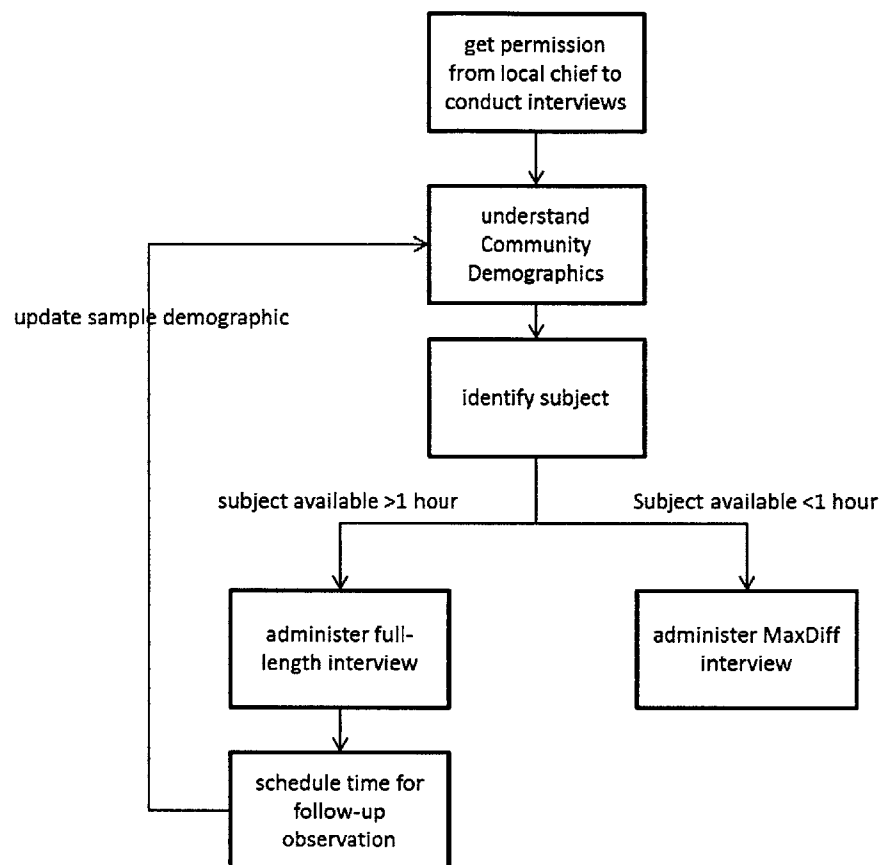

Figure 5: Field Protocol for Stage II New Participants

Identify a sample of subjects

As in the Stage 1 study, we attempted to choose a sample of participants that matched the demographics of the community. However, this was difficult to implement or to measure given the lack of available demographic information and the time and resource constraints for conducting the trial. To maximize the number of participants that would be available for interviewing, we first contacted the village chiefs in order to get permission to interview the

residents of the village. Once the village chief granted his permission, we approached individuals in the community and asked their permission to be interviewed while trying to speak to a representative sample based on our understanding of the community.

Interview and Observation

After explaining the goals of the study, individuals were asked if they were able to participate in a 1-2 hour interview followed by an optional observation session. If the subject was available, we administered a full-length interview (APPENDIX) and scheduled a time for follow-up observation, if possible. When the subjects were unable to commit at least an hour, we administered the shorter MaxDiff only survey (APPENDIX).

2.3 Stage III Uganda

A third stage of field research was developed to extend the study to Uganda to focus on existing solar lantern users. Through a partnership with Solar Sister, a sustainable enterprise that sells solar lanterns through female entrepreneurs, we conducted a field study in July 2013 in Uganda. The purpose of the study was primarily to understand how customers used solar lanterns in the field and to assess their valuation of different characteristics of the solar lanterns.

2.2.1 Community Profile

The regions of interest in the Stage 3 study in Uganda were broadly stratified into Central Uganda and Northern Uganda. The central Ugandan communities consisted of rural areas surrounding Kampala and periurban areas in Kampala and Jinja. The northern Uganda communities consisted of rural and periurban communities in Gulu and Lira. In both regions, the majority of rural users did not have access to grid electricity and used their solar lanterns as their primary source of light. While many of the urban users direct or indirect access to grid electricity, the unreliability in the electricity required them to purchase and use solar lanterns as a backup form of lighting.

2.2.2 Procedure

The procedure for the Stage 3 study consisted of conducting interviews with existing solar lantern users. The protocol overview is shown in Figure 8.

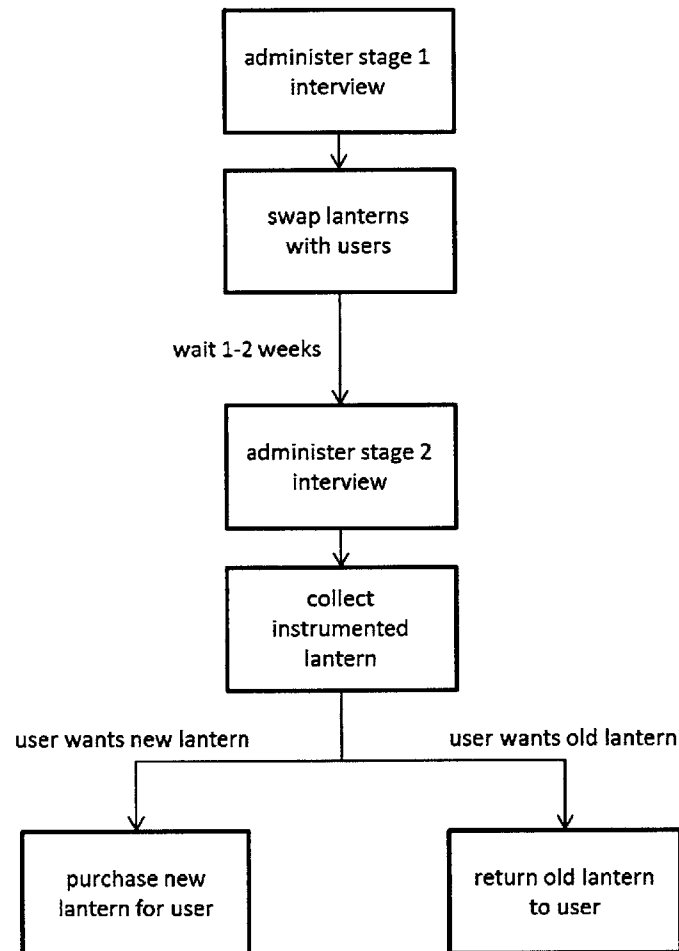

Figure 8: Field Protocol for Stage III Solar Lantern Users

Administering the Uganda Stage 1 Interview

The first step in administering the Stage 1 interview was to find a sample of users of who had been using either the S20 or Firefly solar lanterns. Through our partnership with Solar Sister, the regional coordinators for the organization put us in contact with individual entrepreneurs who had sold either lantern to users near central or northern Uganda in the past three years. Individual entrepreneurs then served as our primary contact to the users and facilitated

connections. Subjects were informed about the terms of the study prior to the Uganda Stage 1 interview and then interviewed for between 30 minutes and 1 hour. The interview created context for the study by asking users how they use lighting in their typical days, explored how users get information relevant to making purchases, and included a MaxDiff component to understand valuation of lighting.

Swapping Lanterns

Users were asked to swap their existing lantern with an instrumented lantern. The instrumentation was described in detail and users were encouraged to ask questions about any reservations they might have. If the user agreed to the lantern swap, we collected their existing lanterns and gave them an instrumented lantern of the same model to use normally for 1 or 2 weeks. A follow-up interview time was scheduled with the users and users were informed that at the end of the study they could choose to retain their original lantern or be provided a newer model of the same lantern type instead. This was done both to thank users for helping with the study and to collect used solar lantern samples from the field for additional testing in lab.

Administering the Uganda Stage 2 Interview

After the instrumented lantern usage period, we returned to the users to administer a follow-up interview. The second interview was a shorter 15 minute to 30 minute interview primarily structured around asking how the user had used their solar lantern in the past week and what their overall thoughts about the product were. Respondents were also asked about the functionality of the instrumented lantern that had been left with them.

Collect Instrumented Lantern

After the second interview, subjects were thanked for helping with the study and the instrumented lanterns were collected. Subjects were given a choice about whether they would like a new lantern or if they would like their old lantern back and respondents

Chapter 3

Field Methods and Results

Table 2 provides an overview of the four different field methodologies that were developed and tested.

	Stage 2 - Ghana		Stage 3 - Uganda
	SOLAR LIGHT USERS	NEW PARTICIPANTS	
Projective Methods	some	some	some
Decision Making Process	yes	no	no
Light Usage	yes	no	yes
Max Diff	yes	yes	some

Table 2: Field Methodologies Developed for Different Stages

3.1 Projective Methods – modified ZMET Analysis

In order to understand individual biases in our data, we performed a modified ZMET (Zaltman metaphor elicitation technique) analysis, which seeks to understand a subject’s conscious and subconscious thoughts through the use of metaphors. A traditional ZMET involves giving participants culturally familiar pictures from magazines, newspapers, and other printed media and having them associate the pictures with the topic of interest (6). The participants can then be asked to fabricate stories revolving around the pictures and the topic of interest. The goal of the analysis was to allow users to better approach usage issues that are otherwise difficult to talk about, such as gender discrimination and poverty, to understand how they affect biases in the data collection. The approach was to show users a solar lighting technology and start with the basic premise that a hypothetical individual who lived in the village had just purchased and returned to the community with the lantern. Users were then asked follow-up questions about what the user would do, allowing them to project their values onto the hypothetical user. The

ZMET analysis was carried out at the initial phase of survey primarily to understand the cultural context and the following observations were made:

The lantern functioned as a status symbol in the community.

Interviewed individuals asserted that the novelty of the light and its aesthetic appeal would make the lantern valuable. One respondent stated that the owner of the lantern would likely take it around town and show as many people as he could. As it provided social value to the user, the he further stated that the male head of the household would use it in public settings and gatherings as often as possible, even though it may bring more utility to his children or his wife.

Theft was not an issue in rural areas.

The novelty of the light made it hard for someone to steal it without repercussions. In the smaller rural communities, theft was not a primary concern for individuals.

Usage Preference.

Two respondents asserted that usage preference would be given to the male head of the household followed by children for reading and homework or his wife for cooking and chores.

3.2 Decision Making Process

In order to better understand the consumer’s product preferences, we included a section of questions aimed at understanding the decision-making process. The questions were aimed at understanding the process that users follow from deciding that they need a light to purchasing one. We model this process in Figure 1Figure 9:

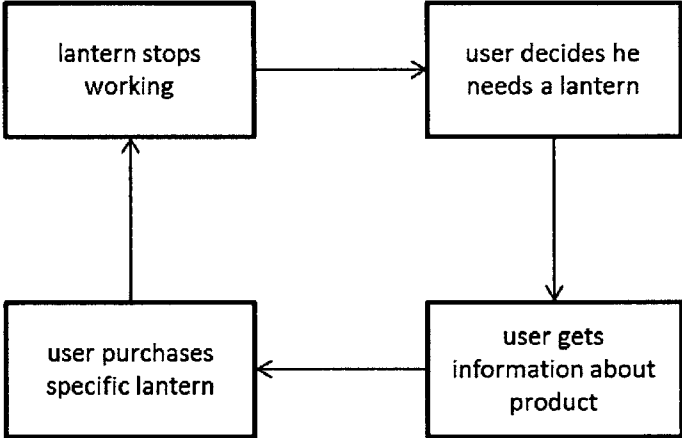

Figure 9: Model of the Decision-Making Process

Getting Information

The survey also aimed at understanding how users gather more information to make their decisions. Of the 20 individuals who responded to the survey, 11 consulted with others, 6 saw someone using the lantern they eventually purchased, and 3 made the decision without consulting anyone. Of the individuals who consulted with others, 6 consulted with people who had used the light before. It is important to note that individuals did not consult any published resources or consult with vendors before purchasing the lanterns.

Purchasing the light

The primary motivator for the purchase of a lighting technology for the consumers was a lack of light caused either by the failure of their previous lighting source or because of lack of access to electricity. The necessity and urgency of the issue are the primary driving factor in the decision to purchase a light for most users. 64% of the 14 respondents from New Longoro and Subingya purchased their light at the first store they went to. Four of the users went to three different stores in the same area and only one user went to the open marketplace to look at different options. This is further corroborated by the distance that users travelled to purchase their lanterns. 15 of the 17 respondents purchased their lanterns within 5 km of their homes, and 11 of those respondents purchased the lights at the nearest shops to them. Further, the two respondents who purchased the lights outside of their neighborhood purchased the lights while they were travelling for other reasons. Of the stores inventoried in the New Longoro community, only 5 types of lighting devices were available. Individuals who made the decisions to purchase lights only considered other options half the time, and otherwise purchased the device that they had thought about directly when going to the store. The data presented is indicative that local availability dominates the decision making process for individuals.

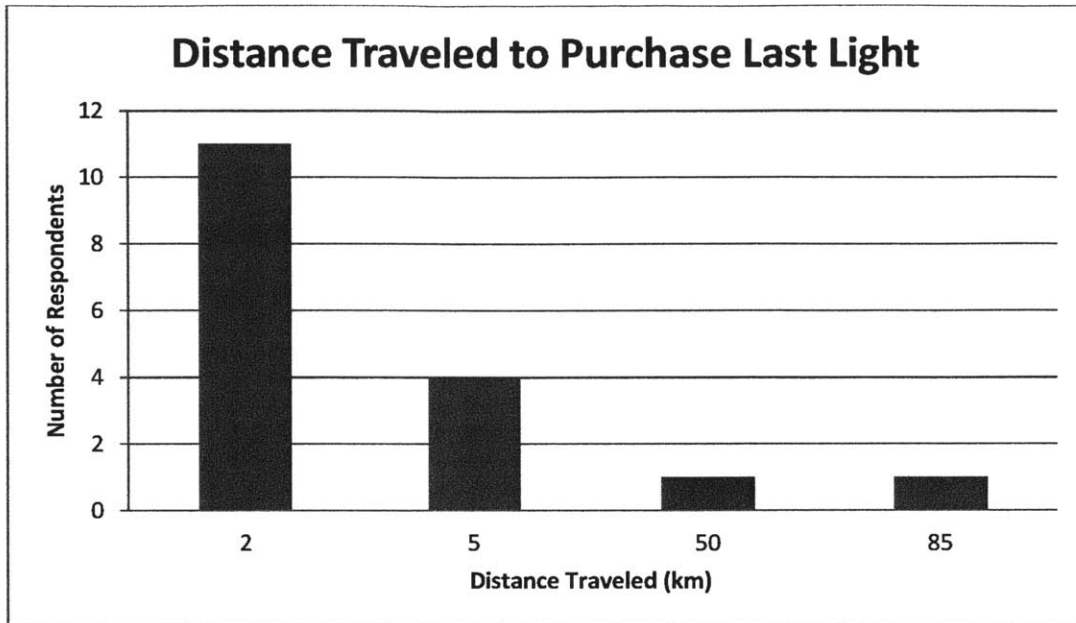

Figure 10: Histogram of Distance Traveled to Purchase Last Light

Individual Role as a Decision Maker

When asked about who made the decision to purchase the previous light source, 15 of the 17 respondents said viewed themselves as the primary decision maker and asserted that they did not need to consult with anyone before purchasing another lighting device. Of the 15 respondents, 10 were male and 5 were female, indicating that this attitude was cross-gender. Only 1 respondent claimed that the decision was made jointly with her husband, and 1 respondent said that she made the decision jointly with her friend.

Usage Period

Individuals were also asked about their last purchase to better understand the frequency and cost of purchases. The respondent's last purchase occurred 4.5 months ago on average, indicative of the replacement period of lighting devices in the community. One user asserted that the flashlights available in the community had very low standards of quality control – one light he purchased lasted him 2 years whereas another similar light which he purchased lasted only 3 days. The average cost of the last purchase for the respondents was GHC 8.1 (approximately 4 USD).

3.3 Solar Lantern Usage

To better understand solar lighting usage, participants in the study were asked about which specific activities and durations of time they used solar lights for. Respondents were initially asked an open-ended question about their usage patterns, and then the following activities were asked about specifically:

- | | |
|-----------------------|--------------------------|
| 1. Cooking | 8. Retail |
| 2. Social Interaction | 9. Manufacturing |
| 3. Outdoor Work | 10. Tending to Livestock |
| 4. Nighttime Security | 11. Agriculture |
| 5. Walking at Night | 12. Preparing the Bed |
| 6. Reading | 13. Other |
| 7. Religious Purposes | |

We asked participants to indicate how many days they had spent using solar lights for the activities in their past week and how many hours per day they used the solar lights for those activities.

3.3.1 Usage in Ghana

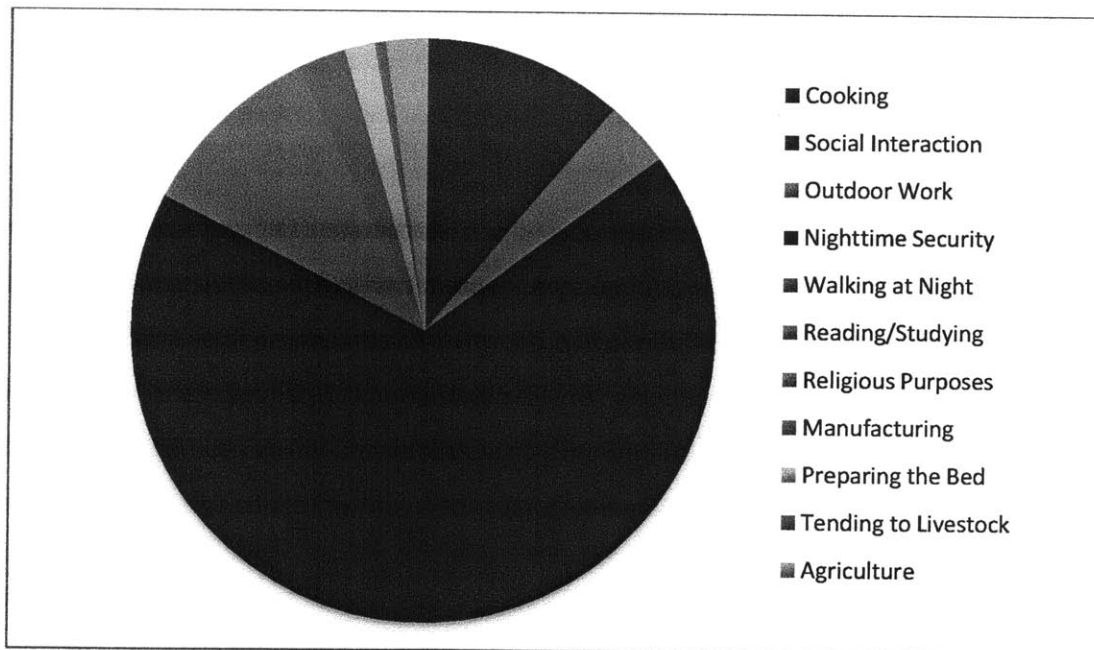

Figure 11: Solar Lantern Usage Distribution in Ghana

The responses were aggregated from the 11 solar lantern users in Ghana and are displayed in Figure 11. We can see that use of the product as a nightlight for nighttime security dominates the use phase of the product. However, the quality of light was of little significance in its use as a night light as indicated by several of the participants and the lights were kept on as night because it was free for them to do so. Figure 11 indicates that among the other uses of the solar lights, cooking and reading accounted for about half of active usage in the communities.

3.3.2 Usage in Uganda

Responses from the 38 users in Uganda were aggregated and displayed in Figure 12. Similar to Ghana, the product was used longer as a nightlight than for any other purpose; however it did not dominate the use phase. In addition, cooking, reading, social interaction, religious purposes, and general illumination each constituted large percentages of usage duration.

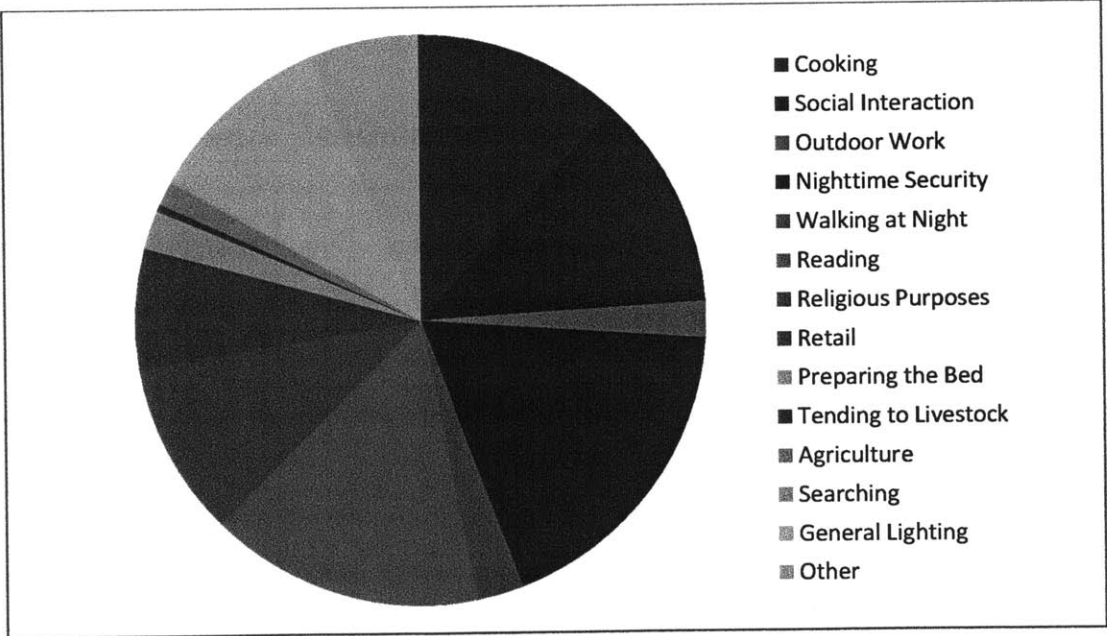

Figure 12: Solar Lantern Usage Distribution in Uganda

3.4 Maximum Difference Analysis

The max-diff analysis (also known as best-worst scaling) is a data analysis method designed to show relative preferences from a collection of choices. The strength of the analysis is that it allows for the assessment of degree of importance of a set of objects relative to each other. Traditional rating scales introduce response biases between differing users, for example, one user may rate a product a 4 out of 5 while another user who values that product the same may scale his responses differently. Further, the use of rating scales is not common in rural Ghana or Uganda, which exacerbates the problem. Max-diff analysis avoids this response bias by only providing a best and worst option for each dataset, and when constructed properly, provides a series of choice sets that includes the items of interest and possible comparisons an equal number of times (7). In the design of our study, we presented 11 attributes in 12 different choice sets to the various respondents where each attribute was paired against each other attribute 3 times Table 3.

	QUESTION NUMBER											
	1	2	3	4	5	6	7	8	9	10	11	12
Area Illuminated				X	X		X	X		X	X	
Battery Life	X		X				X		X	X	X	
Brightness			X		X			X	X		X	X
Charging Time	X			X				X	X	X		X
Cost		X				X		X	X	X	X	
Durability			X			X	X	X		X		X
Ease of Repair	X	X					X	X			X	X
How it Looks /Mobile Charging		X	X	X						X	X	X
Mobility				X		X	X		X		X	X
Number of Settings		X			X		X		X	X		X
Water Resistance	X				X	X				X	X	X

Table 3: Design of the Max-Diff Survey

The standard score, which is a normalized metric for the degree of importance for each attribute, can be calculated by using the formula:

$$SS = \frac{N_{best} - N_{worst}}{6n}$$

Where N_{best} = the number of times an attribute appeared as most important

N_{worst} = the number of times an attribute appeared as least important

N = the number of questionnaires

The standard scores for each attribute were calculated and are plotted in Figure 13 and Figure 14.

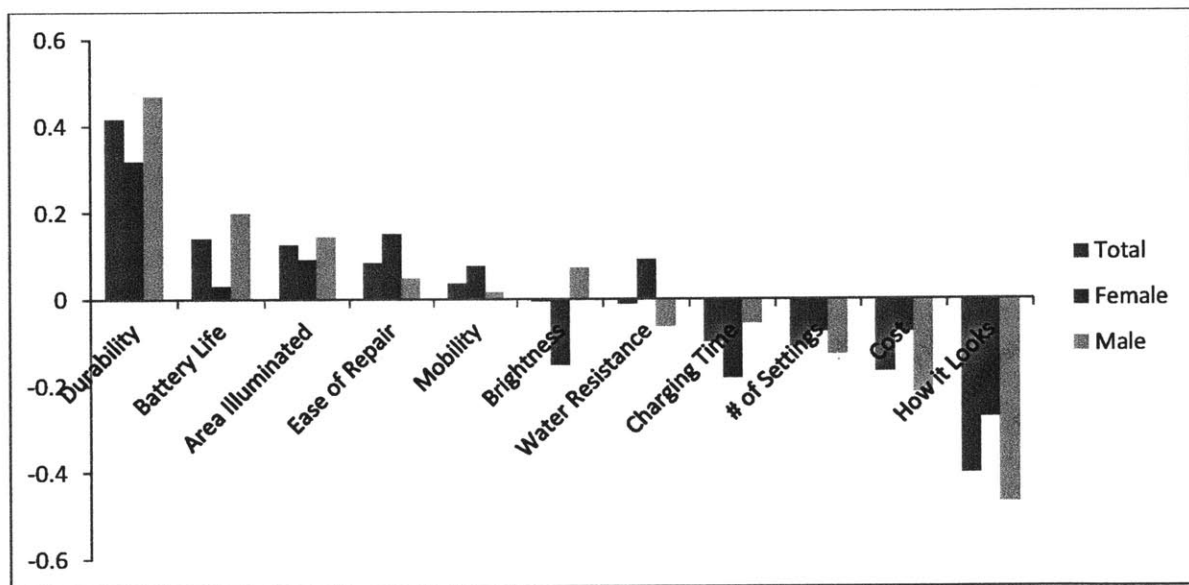

Figure 13: Standard Scores for Different Attributes of Solar Lighting from Stage II Ghana

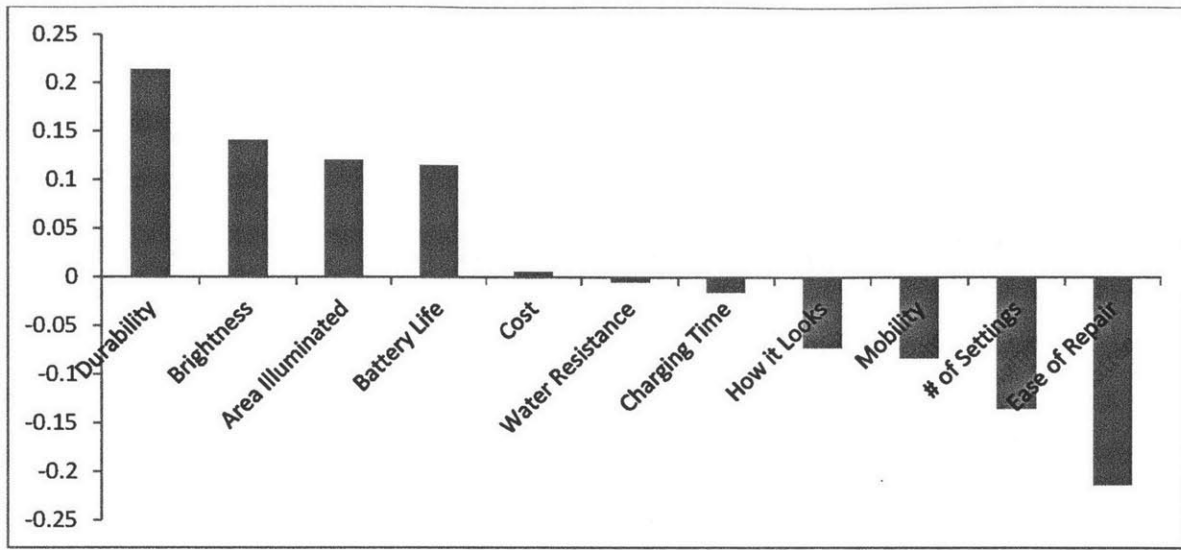

Figure 14: Standard Scores for Different Attributes of Solar Lighting from Stage III Uganda

Chapter 4

Photodiode Array and Integrating Box

The characterization of a light source is often a challenging task. While many of the solar lighting evaluation systems measure overall light output in lumens as an indicator of the brightness and functionality of the product, it is traditionally both difficult and expensive to measure and also an incomplete metric as it does not account for the distribution of the light. Traditional approaches to measuring total light output use an integrating sphere, a spherical enclosure that acts a near-perfect reflector and diffuser to physically distribute light evenly over its surface. The luminous flux can be then measured at any point on the surface to the sphere to calculate the overall light output. However, due to the nature of the device, the integrating sphere loses all information about initial light distributions. Because of the high cost of such a device and lack of information about light distribution, we have designed an alternative “integrating box” which is a closed non-reflective/non-diffusive surface with several photodiodes to measure the lighting level at various physical points on the surface. The values from these photodiodes can then be integrated mathematically to approximate overall light output. While it is less precise than an integrating sphere, the added functionality and lack of precision required for lantern characterization.

4.1 Measuring Brightness

To measure the luminous flux of a device, the power output at each wavelength of light is weighted using the luminosity function $\bar{y}(\lambda)$ to model the brightness of the source object as perceived by the human eye (8). The total luminous flux can then be found using the following formula:

$$F = 683.002 \text{ lm/W} \cdot \int_0^{\infty} \bar{y}(\lambda) J(\lambda) d\lambda$$

where

F is the luminous flux in lumens

$J(\lambda)$ is the spectral power distribution of the radiation (power per unit wavelength), in watts per meter.

$\bar{y}(\lambda)$ (also known as $V(\lambda)$) is the standard luminosity function (which is dimensionless).

λ is wavelength in meters.

However, if the light output spectrum is constant, the spectral power distribution can be represented as $J_{Device}(\lambda) = C_{Device} J_{LED}(\lambda)$

The total luminous flux can then be simplified to

$$F = C_{Device} F_{LED}$$

To obtain F , the light intensity, or the luminous flux per unit area (F/A), can be measured directly and this value can be integrated over a closed surface to measure the total luminous flux. We can approximate this surface integral by splitting the surface into smaller components and measuring the flux in each of those elements and adding them:

$$\int J dA \approx \sum_{n=1}^N \left(\int_0^{inf} J(l) * D(l) dl \right) * \frac{A_{RA}}{A_M}$$

where

$\left(\int_0^{inf} J(l) * D(l) dl \right)$ is the measured light intensity (lux)

A_{RA} is the representative area

A_M is the measured area

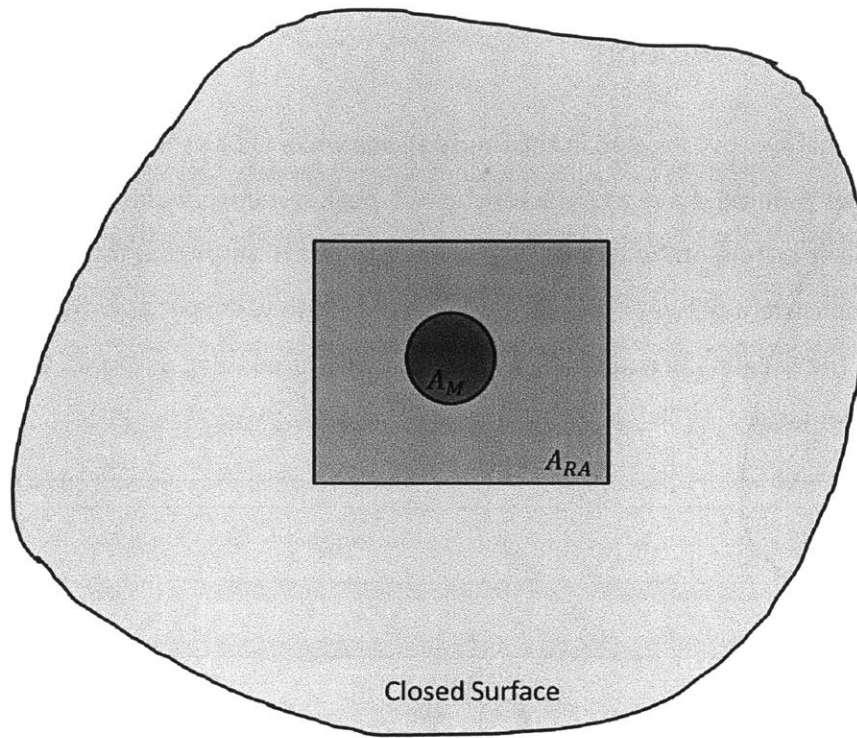

Figure 15: Diagram of the Measurement of a Closed Surface with a Representative Area

4.2 Spectral Measurements

The solar lights that we investigated in this study all use white LEDs as their source of light. While white LEDs generally have a characteristic two-peak system, it was important to characterize the spectrum of the lanterns we wanted to test to verify that the light output spectrum was consistent between different models of light to verify our assumptions. The light spectrum from the D-light S20 and Firefly Mobile was measured using an Ocean Optics USB4000 spectrometer.

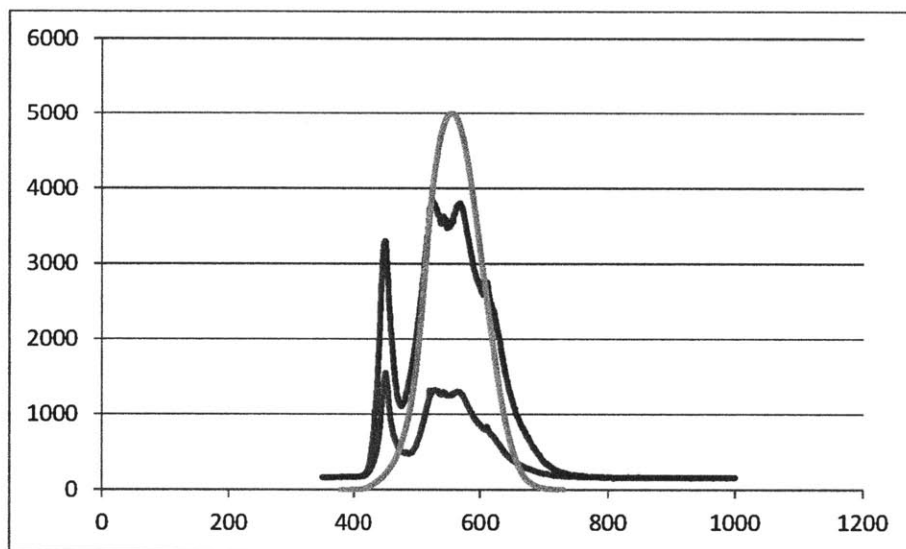

Figure 16: Normalized Spectra for the DLight and Firefly lights plotted with Luminosity Function

As shown in **Figure 16**, the both lanterns exhibit similar spectral power distributions, which are twin peaked at around 450nm and 550nm. While we can observe differences in the relative intensities at 450nm and 550nm for the two samples, when overlaid with the luminosity function as shown in **FIGURE**, it is evident that the 450nm peak is out of the range of interest for the luminosity function and therefore brightness measurements.

4.3 Measurement System

As demonstrated in 4.2 the spectral power distributions were similar for the different source lights of interest. As a result, photodiode calibrated to a white LED light could serve as a

cheaper alternative to direct photometer measurements. The TEFD4300 photodiode from Vishay Semiconductors provided a linear reverse light current vs irradiance curve and had a low price point, making it an ideal choice for this application. The photodiode was run in reverse bias mode and a LM324 Operational Amplifier was used with a $1\text{M}\Omega$ as a current-to-voltage converter to allow for measurement as shown in Figure 17.

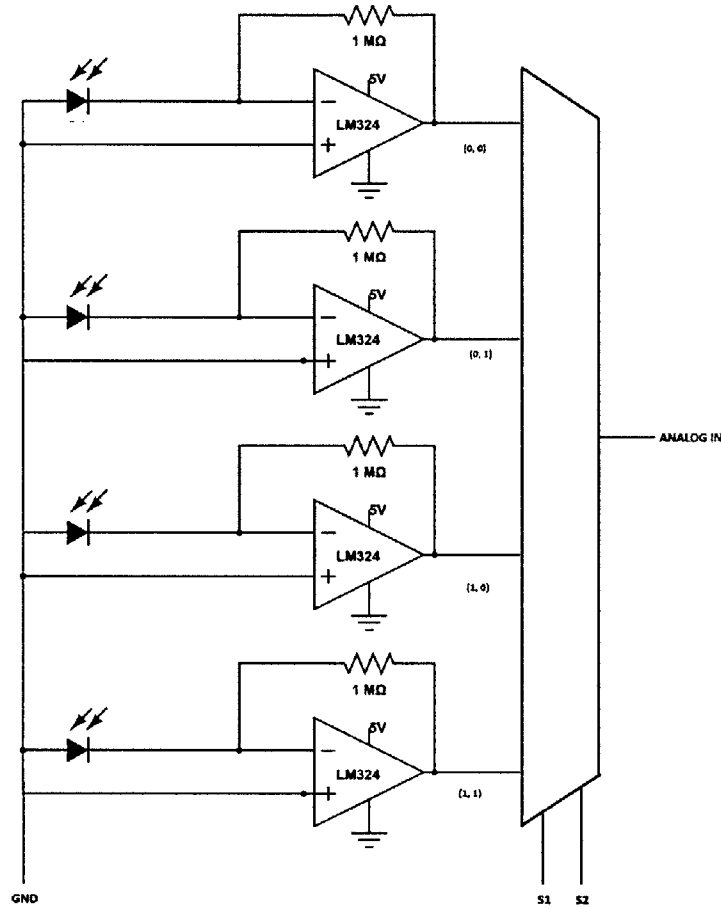

Figure 17: Circuit Diagram for the Photodiode – OpAmp – Multiplexer System

To cheaply measure and log data for the system, an Arduino Mega microcontroller with 16 analog inputs was used to measure the output from the photodiodes. To allow for measurements from more photodiodes, we used a low-impedance multiplexer controlled by the D2 and D3 digital outputs of the microcontroller as shown in Figure 17.

4.4 Photodiode Layout

Several different configurations of photodiodes were designed and tested to measure light output. To reach a high enough density of photodiodes, we chose the configuration shown in Figure 18. The 45-photodiode configuration provided a higher concentration of photodiodes near the center where more variation was present.

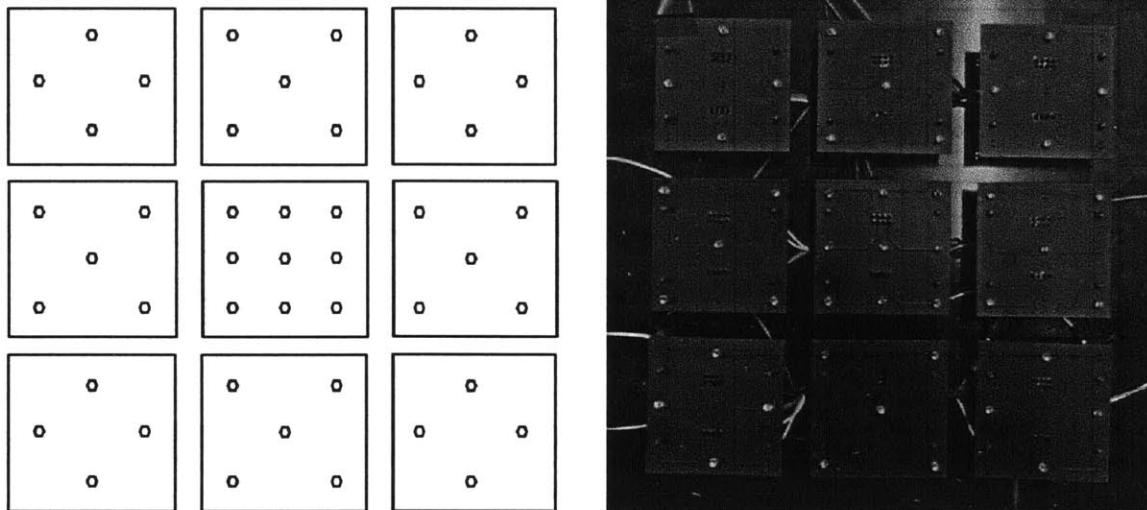

Figure 18: Photodiode Layout

To arrange the photodiode arrays, we developed a modular PCB design that could allow for the selection of multiple photodiode detectors. Each panel was designed to hold 9 photodiodes spaced 1" apart from each other. The board layout and schematics for the PCB are shown in Figure 19. To construct one wall of the device, 9 photodiode panels were mounted to a 0.25" ABS sheet with 1" spacers, allowing for a maximum of 81 photodiodes per wall.

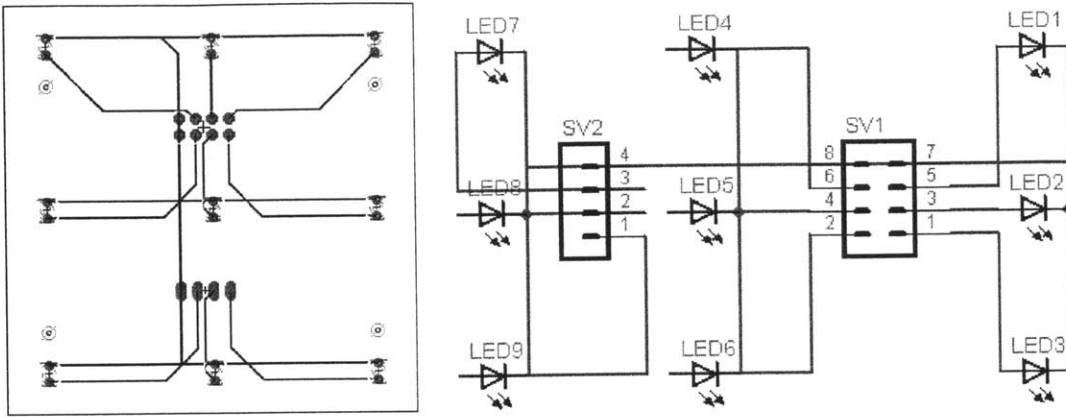

Figure 19: Photodiode Board Layout and Schematic

To create the lightbox, 6 walls were fabricated and attached together using 80 x 20 T-Slot framing as shown in Figure 20. The box was covered in foam to facilitate transportation in Uganda.

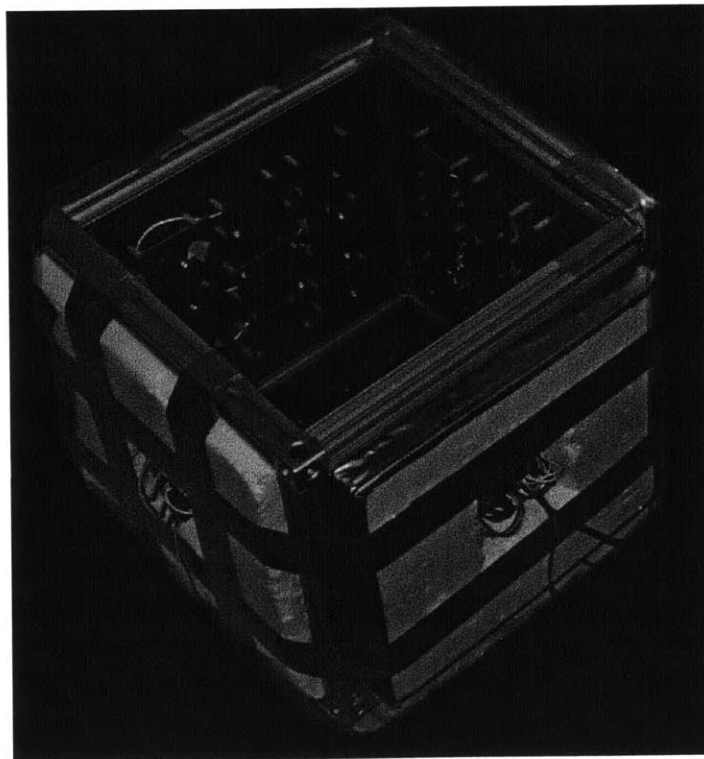

Figure 20: Assembled LightBox

4.5 Calibration

To ensure accurate readings from the photodiode array, each photodiode was calibrated individually against an Extech HD450 Light Meter using white LED light source was placed a variable distance away from the photodiode. The calibration curve plotted the voltage output of the amplified photodiode signal against light intensity (lux) to allow for correlation between the two. A sample calibration curve is shown in Figure 21. A linear fit was used to calculate the scaling coefficients to estimate light intensity from the voltage reading.

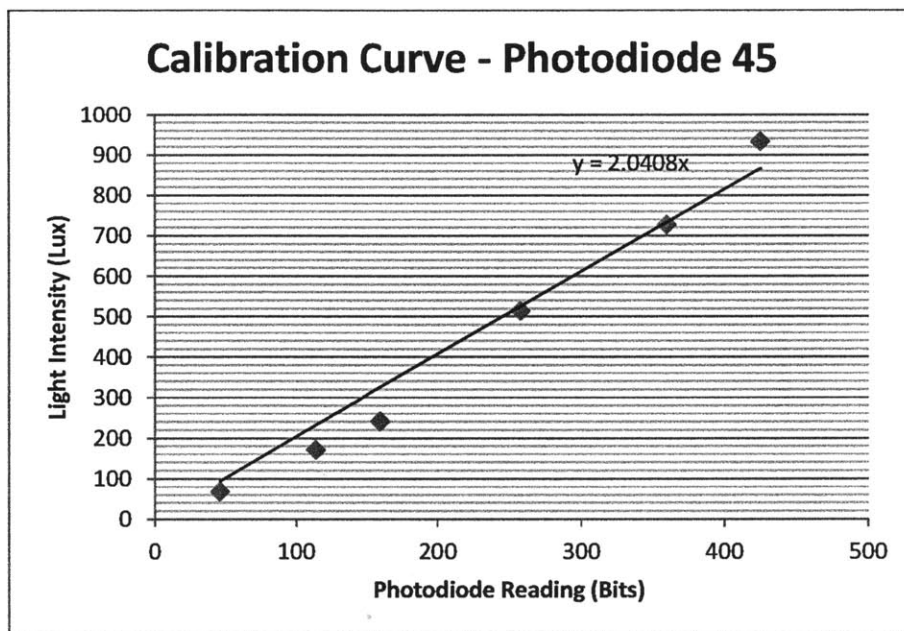

Figure 21: Sample Calibration Curve for a Photodiode

4.6 Measurement & Results

Sample solar lanterns were placed in 6 orientations relative to the calibrated plane to measure incident light on the surface. Each lantern was placed 6 inches above the plane of the light and the photodiode output was measured 5 times and averaged. Values for each photodiode reading were scaled to light intensity output using the calibration as demonstrated in 4.5.

To visually present the data from the photodiodes, we conducted a 3D interpolation on MATLAB using the `griddata` function and took planar and spherical volumetric slices as shown in Figure 22. The graphs serve as a demonstration of the total light output of each device, allowing for assessment of the brightness and directionality of lighting provided by the various products. We can clearly see that of the three test samples, the Firefly has the highest light output.

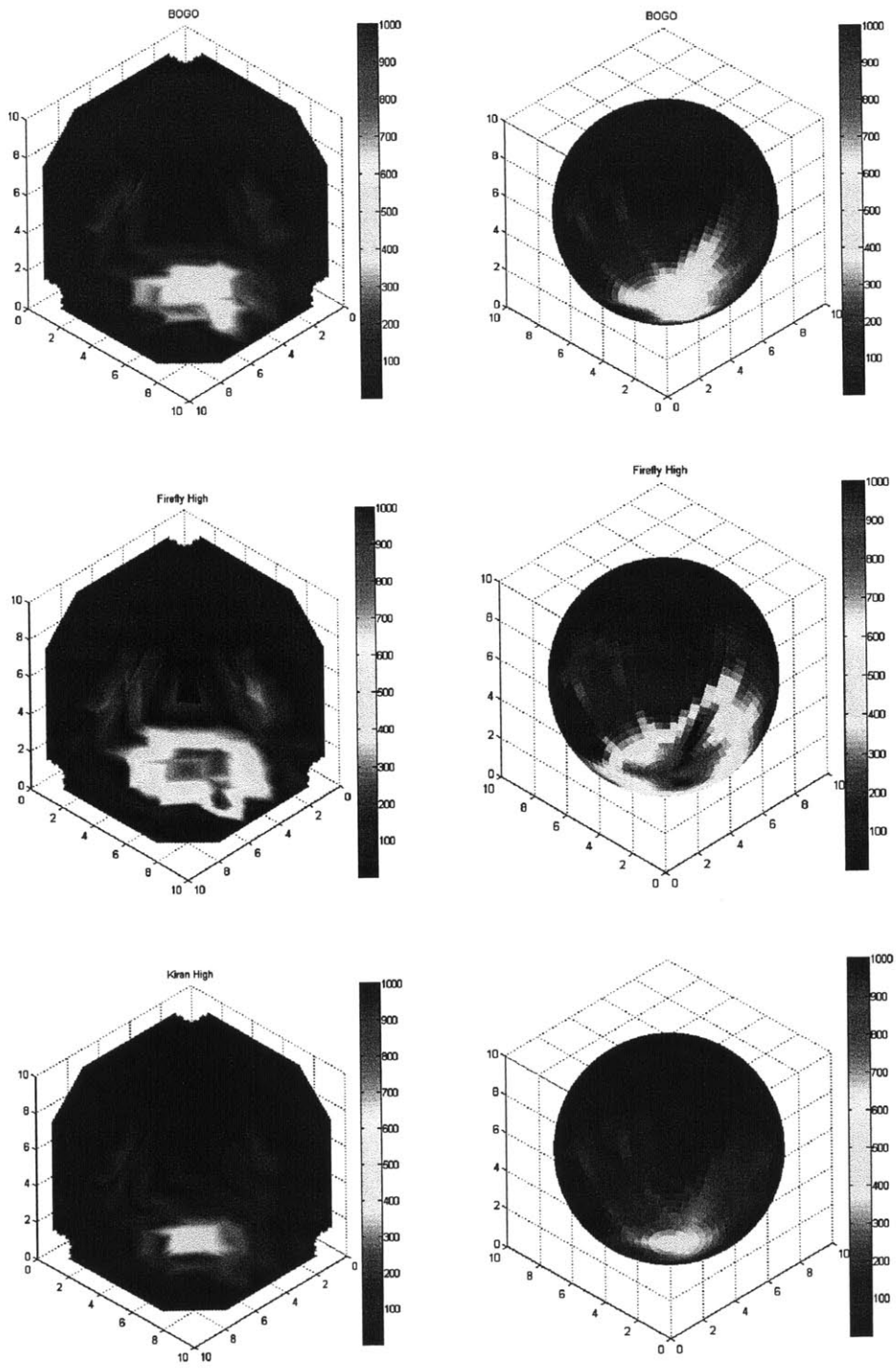

Figure 22: Light Output Diagrams from LightBox

Chapter 5

Embedded Instrumentation

Respondents in the initial stages of the survey estimated their usage of solar lanterns to the best of their abilities, however there was still uncertainty in their responses. In order to understand this response bias and track the usage and performance of solar lanterns in the field, an embedded instrumentation system was designed to log data on the usage state of the lantern (ON/OFF/CHARGING) and the acceleration profile. The instrumentation was installed in the S20 and Firefly Mobile lighting systems and deployed in the field for a test usage period of 1-2 weeks to users who had been using the same type of solar lantern.

5.1 Design of the system

The design of the instrumentation system consisted of integrating the subsystems while optimizing the overall system for size and power consumption. The instrumentation system consisted of the following four components: an Arduino Pro-Mini 3.3V microcontroller, an ADXL362 3-axis accelerometer, a microSD breakout board, a PCB to integrate the components and a 3.7V 1000mAh Lithium Polymer battery to power the system. The overall architecture of the system is shown in Figure 23.

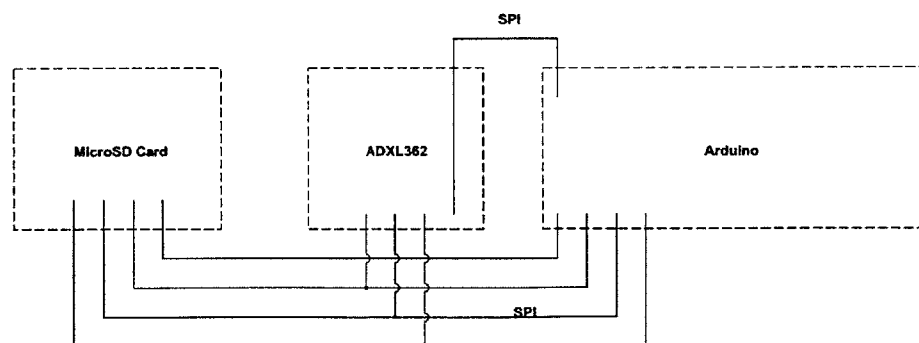

Figure 23: Overall System Architecture

5.1.1 Selection of Components

The Arduino Pro-Mini 3.3V microcontroller was chosen for the system primarily because of its small size and low-power functionality. The board is powered by an ATmega328 running at 8MHz and weighs about 2g and is approximately 18mm x 33mm x 1mm in size. The ATmega328 has 8 analog inputs with 10-Bit ADCs and 14 digital inputs, which allowed for interfacing with the In addition, the board operates at 3.3V, serving the dual purpose of allowing for low-power consumption and allowing for direct interfacing with external devices that operate at 3.3V, such as an SD card.

In order to log data over a period of several days at the sampling rate required to characterize performance, an external storage medium was required. A microSD card was chosen because of its small footprint and ease of accessibility and interfacing. Because the microcontroller operated at 3.3V, the device could interface directly with a microSD card without the need for logic-level shifting and allowed for direct data-logging.

Finally, to record data about the acceleration profile, the ADXL362 accelerometer was chosen due to its low-power consumption and interrupt capabilities. Operating at 3 MICROWATTS, the accelerometer allowed for measurement in 3-axis accelerometer and recorded temperature as well. Further, the ADXL362 had a programmable interrupt, which could be set to control the system in case of high acceleration.

The overall system architecture consisted of the following steps.

CASE 1: LANTERN OFF

RECORD ONE DATA POINT AND SLEEP FOR 8S

CASE 2: LANTERN ON

RECORD DATA FOR 2S AND SLEEP FOR 8S

INTERRUPT: HIGH ACCELERATION

RECORD DATA FOR 4S AND SLEEP FOR 8S

5.1.2 Design of PCB

We designed a PCB to mount the individual sub-components of the device and interface with the solar lanterns. The PCB was rapid-prototyped using a Roland Modela and then externally fabricated. The overall dimensions for the 2-layer PCB were 1" x 3" x .02", allowing for it to be installed into both test lantern models.

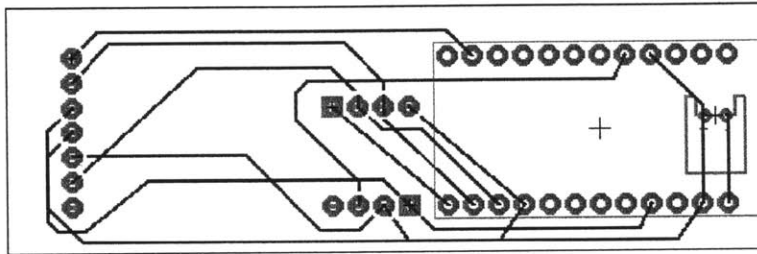

Figure 24: PCB Designed for Instrumentation System

5.1.3 Operation Mode Characterization

In order to understand the how the lanterns were being used, it was important to characterize the mode they were being operated at. Depending on the lantern type, these modes could be high, low, off, or charging. To characterize the mode, the system measured the current by measuring the voltage drop across a 0.5 Ω shunt resistor in series with the battery Figure 25.

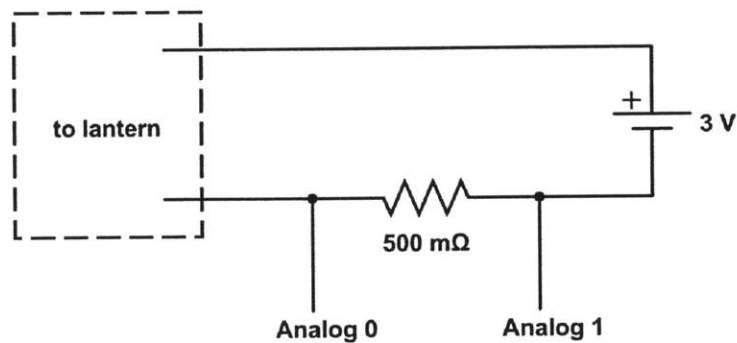

Figure 25: Circuit Diagram for Current Measurement System

The analog inputs of the ATmega328 have a 10-Bit ADC capable of measuring 1024 values between 0V and 3.3V, providing a 3.2mV resolution for the recorded measurements. By measuring the difference between the analog0 and analog1 inputs and recording the

corresponding usage, we were able to correlate the usage mode to the voltage difference as shown in

Table 4.

D-Light S20		Firefly Mobile	
Voltage Difference	Mode	Voltage Difference	Mode
30mV to 40mV	HIGH	60mV to 80mV	HIGH
10mV to 20mV	LOW	20mV to 40mV	MED
0 mV	OFF	5mV to 10mV	LOW
-5mV to -30mV	CHARGING	0 mV	OFF
		-5mV to -30mV	CHARGING

Table 4: Voltage Differences and Corresponding Usage States

Figure 26 shows a 3-hour sample-frame of usage from a D-Light S20 and a 2-hour sample-frame from a Firefly.

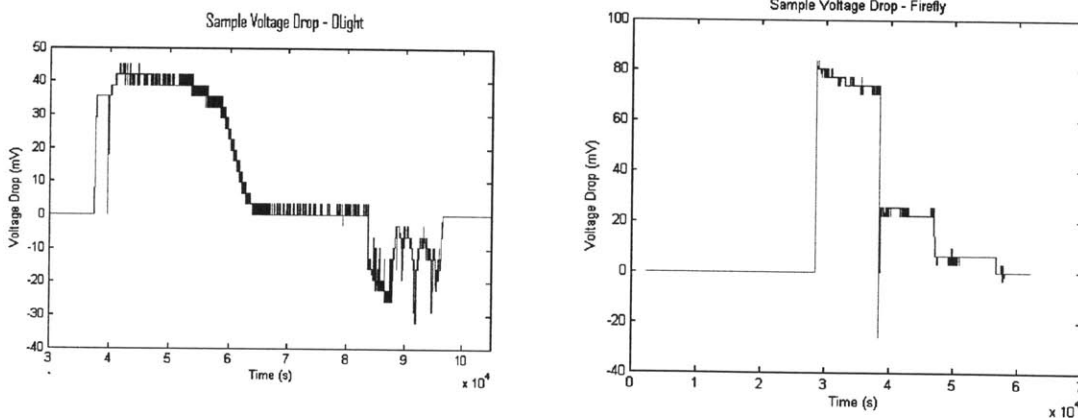

Figure 26: Sample Usage Frame for D-Light (left) and Firefly (right)

5.1.4 Accelerometer Measurements

The operational state of the device is indicative of overall use patterns, but does not capture specific usage information during that period of usage. In order to understand how lanterns were being used in the field, we incorporated accelerometer measurements into our

instrumentation. While no direct field assessments were made to correlate acceleration profiles to usage information, the development of this instrumentation served as a proof-of-concept for future testing and evaluation modules. The accelerometer-datalogging system measured X-axis, Y-axis, and Z-axis acceleration over the full usage period of the solar lanterns in the field and sampled at a rate of 0.2 seconds while in the logging state. The intent of the instrumentation was to assess two factors, the orientation of the product and its intensity of use. The orientation of the product can be assessed by comparing the X-axis, Y-axis, and Z-axis readings at a steady-state; different relative readings correspond to different physical orientations. Further, the intensity of use can be calculated from measuring the rate of change in the X, Y, and Z, accelerations as high intensity use scenarios will cause more rapid accelerations in the device.

Figure 27 captures a 5 minute interval in the usage of a D-Light S20 lantern in the field. As can be seen in the figure, the lantern starts off in a stationary position, is used actively for 2 minutes, and is returned to a stationary position.

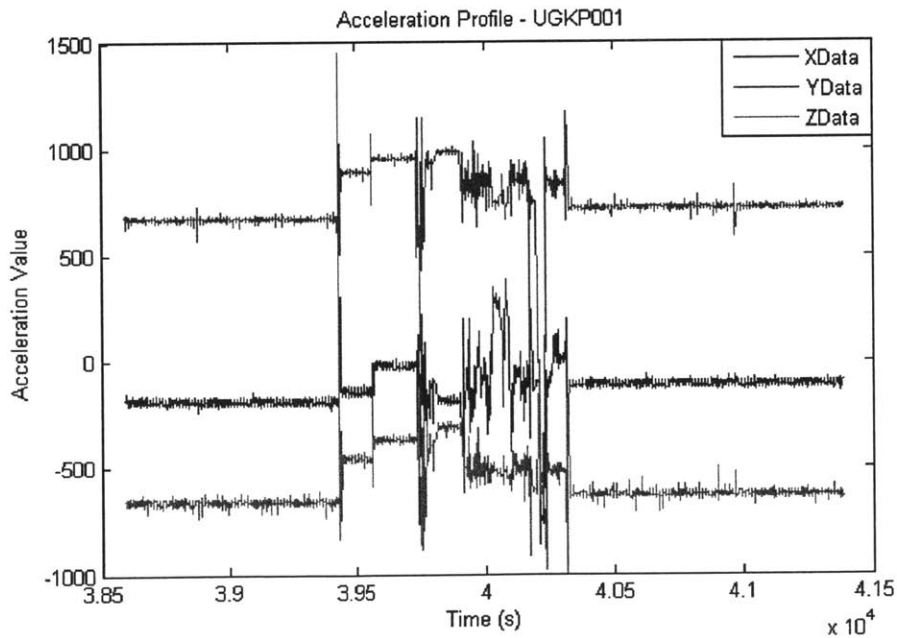

Figure 27: Sample Acceleration Profile for a D-Light

5.2 Integration into Solar Lantern

We installed instrumentation of the testing system into 50 individual solar lanterns. The integration process consisted of four parts, fabricating the complete chip, installing the chip into the solar lantern, starting the acquisition and retrieving the data.

5.2.1 Fabricating the Chip

The first step of integrating the device into the lanterns involved the fabrication of the fully functional chip. The individual components, the Arduino ProMini board, microSD holder, ADXL362 and battery pin connectors were soldered to the PCB using through-hole headers. Lead wires were soldered to the Analog0, Analog1, and ground pins of the board. After testing the board for connectivity, a microSD card was inserted into the holder and the board was programmed using an FTDI board. Figure 28 shows a complete board.

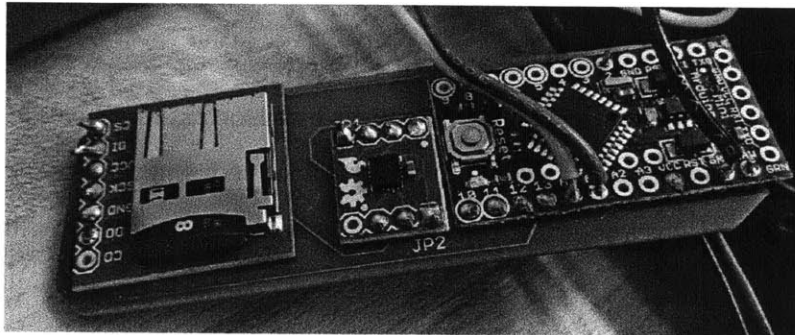

Figure 28: Completed Instrumentation Board

5.2.2 Installing the Chip

To second step of integration was to install the chip into the solar lanterns. The solar lanterns were taken apart and the battery was removed. The shunt resistor was then soldered across the ground wire of the battery and the two leads from the Analog0 and Analaoog1 pins were soldered to the resistor. Finally, the ground lead was soldered to the solar lantern ground.

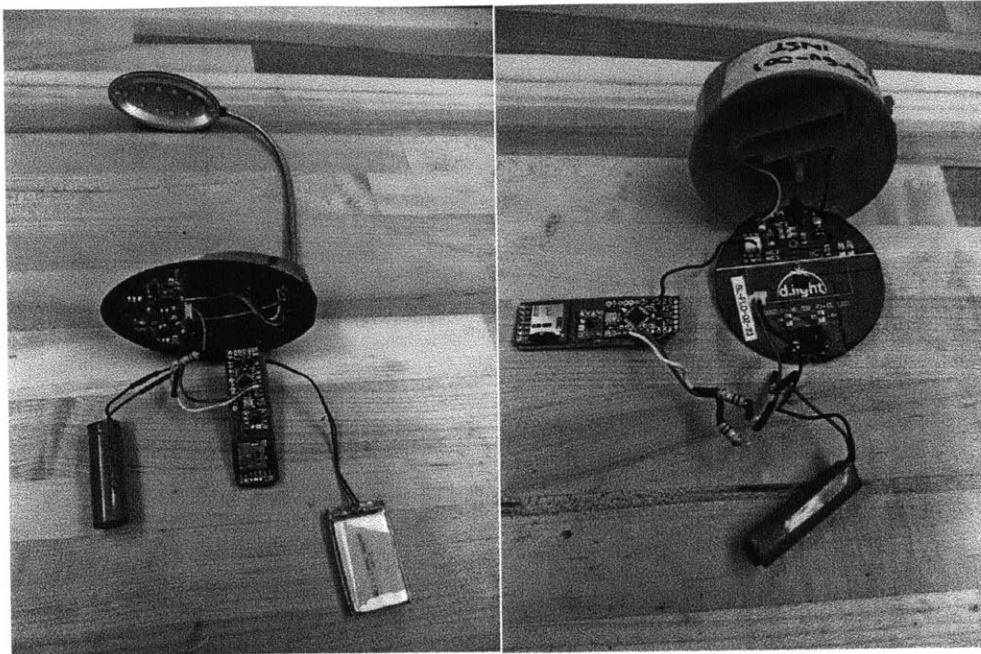

Figure 29: Solar Lanterns with Instrumentation Installed. Left: Firefly. Right: D-Light.

5.2.3 Starting Acquisition

The third step in the preparation of the solar lantern instrumentation system was to start the system for logging. Once the chip was installed, the following procedure was followed to ensure appropriate data collection.

1. Unscrew solar lantern
2. Unplug both the solar lantern battery and the instrumentation battery
3. Format microSD card and place into holder
4. Plug-in battery to the instrumentation
5. Record instrumentation start time
6. Plug-in battery into the solar lantern
7. Place device inside solar lantern in the proper orientation
8. Close solar lantern

Each solar lantern was assembled and tested using the above protocol. Prior to field deployment, the protocol was followed again and lanterns were deployed with 48 hours of starting acquisition.



Figure 30: Solar Lanterns with Instrumentation Embedded. Left: Instrumented Lanterns. Right: Normal Lanterns.

5.2.4 Retrieving Data

The final step was to retrieve the data after the lantern had been collected from the user. To mitigate the risk of damaging the data during retrieval the following protocol was followed:

1. Leave lantern on high state in the upright position for 5 minutes
2. Turn off lantern
3. Open lantern carefully
4. Unplug solar panel battery
5. Unplug instrumentation battery
6. Record stop time
7. Remove microSD card and save data

5.3 Results

The field instrumentation results demonstrate significant error in usage reporting. 37 out of the 41 field deployed lanterns functioned properly. Overall reported lantern usage data was aggregated from the field study and compared to measured usage. Specifically, the total hours of use over the past week was calculated for each user and converted to a usage percentage by dividing by total number of hours in the week. A MATLAB script was written to calculate the percentage of time the lantern was in any of the on states. Percentage error was calculated using the following formula:

$$Error = \frac{\%report - \%measured}{\%measured}$$

	Reported Usage	Measured Usage	Percentage Error
D-Light S20	27.29%	12.64%	115.77%
Firefly	24.35%	14.17%	71.75%
Combined	25.37%	13.22%	91.80%

Table 5: Percentage Error in Average Usage

Table 5 shows the average reported usage compared to the average measured usage for both solar lantern models individually and combined. We can observe a large error in reported usage for both lantern types.

Subject ID	Error	Lantern	Subject ID	Error	Lantern
UG-GU-001	80.80%	DLIGHT	UG-GU-006	188.14%	FIREFLY
UG-GU-002	283.75%	DLIGHT	UG-GU-010	-13.47%	FIREFLY
UG-GU-003	215.75%	DLIGHT	UG-GU-109	134.72%	FIREFLY
UG-GU-004	1582.76%	DLIGHT	UG-KP-002	123.51%	FIREFLY
UG-GU-005	758.41%	DLIGHT	UG-KP-003	-66.31%	FIREFLY
UG-GU-007	55.57%	DLIGHT	UG-KP-004	444.16%	FIREFLY
UG-GU-008	63.04%	DLIGHT	UG-KP-005	-76.64%	FIREFLY
UG-GU-009	-21.16%	DLIGHT	UG-KP-006	16.29%	FIREFLY
UG-GU-101	-92.56%	DLIGHT	UG-KP-008	145.85%	FIREFLY
UG-GU-102	-30.86%	DLIGHT	UG-KP-101	126.94%	FIREFLY
UG-GU-103	301.54%	DLIGHT	UG-KP-103	35.50%	FIREFLY
UG-GU-105	76.17%	DLIGHT	UG-KP-104	9.52%	FIREFLY
UG-GU-107	26.36%	DLIGHT	UG-KP-105	69.67%	FIREFLY
UG-GU-108	296.08%	DLIGHT	UG-KP-109	94.57%	FIREFLY
UG-KP-001	70.87%	DLIGHT			
UG-KP-007	3546.63%	DLIGHT			
UG-KP-009	388.59%	DLIGHT			
UG-KP-010	54.00%	DLIGHT			
UG-KP-011	93.60%	DLIGHT			
UG-KP-102	143.42%	DLIGHT			
UG-KP-106	62.76%	DLIGHT			
UG-KP-108	227.34%	DLIGHT			
UG-KP-110	670.82%	DLIGHT			

Table 6: Individual Errors in Reported Usage for Each User

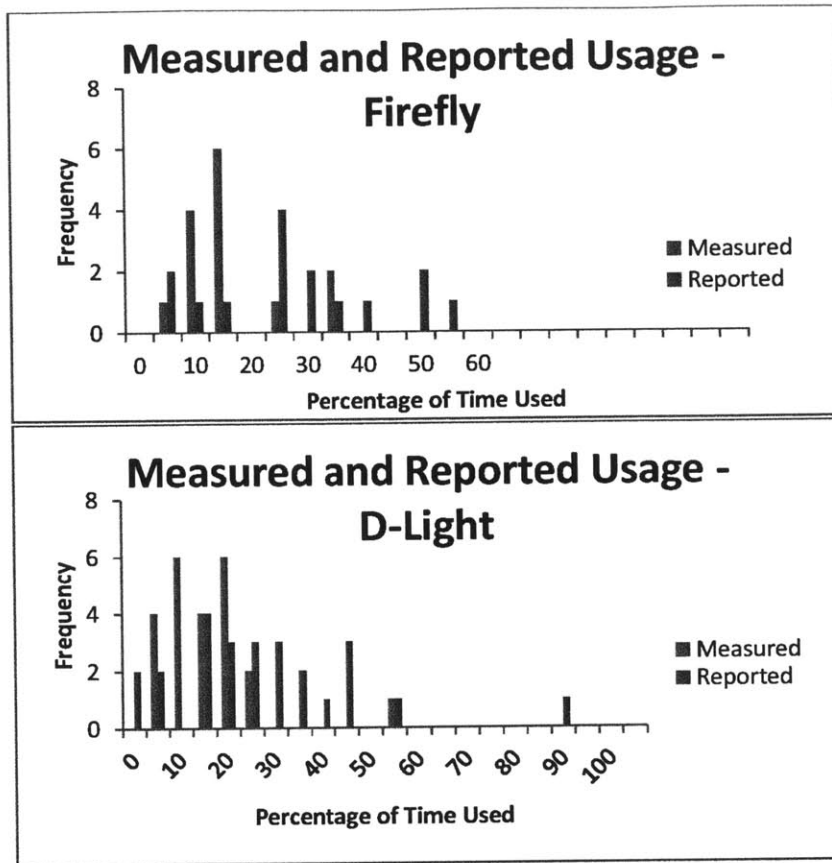

Figure 31: Histograms of Usage Error. Top: Firefly. Bottom: D-Light.

Figure 31 depicts histograms of reported and measured usage. We can see the clear overestimation of reported usage for both models of light. While we cannot assess the causes for over reporting, we have provided groundwork for future research in the subject.

Chapter 6

Conclusions and Future Work

In this thesis, we explored the evaluation and testing of solar lantern technologies and presented both field and lab testing strategies and results to promote better assessment. Through the use of projective methods in field analysis, we were able to better identify sources of bias in reporting and draw insights towards information that is traditionally difficult to gather. Further, through the application of the Max-Diff methodology, we were able to understand user valuations of the different characteristics of solar lighting. The application of this methodology in assessment frameworks in developing countries demonstrates the ability to gather this information quickly through fieldwork.

Through our instrumentation and lighting usage data collection, we were able to demonstrate a significant over reporting of usage by users. There are primary implication of the over reporting of information based on market research is that design requirements in the development of solar lantern technologies that are market based may carry this over reporting bias – causing technologies to potentially have a longer battery life and consequently price than actually required. Since solar lanterns are a price sensitive consumer market where designs are heavily optimized for cost, development of cheaper lanterns that are functional would positively impact adoption rates.

References

1. *Product Quality in the Kenya Solar Home Systems Market*. Duke, R. D., A. Jacobson, and D. M. Kammen. s.l. : Energy Policy, 2002, Vol. 30.
2. Lighting Africa Project. [Online] www.lightingafrica.org.
3. **Lighting Africa**. *The Off-Grid Lighting Market in Sub-Saharan Africa: Market Research Synthesis Report*. 2011.
4. **CELADE - Population Division, ECLAC; National Institute of Statistics, CAMBODIA**. Cambodia General Population Census 2008. <http://celade.cepal.org/khmnis/census/khm2008/>. [Online]
5. **Ghana Statistical Service**. Ghana General Population Census 2010. <http://www.statsghana.gov.gh/>. [Online]
6. *Mapping Consumers' Mental Models with ZMET*. Olson, Glenn L. Christensen and Jerry C. 6, s.l. : Psychology and Marketing. , June 2002., Vol. 19.
7. *Best-Worst Scaling: A Simple Method to Determine Drinks and Wine Style Preferences*. **Steven Goodman, Larry Lockshin, Eli Cohen**. Sonoma. : International Wine Marketing Symposium., 2005.
8. **Stiles, G. Wyszecki and W. S.** *Color Science: Concepts and Methods, Quantitative Data and Formulae*. s.l. : Wiley Classics Library Edition, 2000.
9. *The need for independent quality and performance testing for emerging off-grid white-LED illumination systems for developing countries*. **Mills, E., & Jacobson, A.** 5-24, s.l. : Light & Engineering, 2008, Vol. 16(2).
10. *The Off-Grid Lighting Market in Western Kenya: LED Alternatives and Consumer Preferences in a Millennium Development Village*. **Mills, E., & Jacobson, A.** s.l. : The Lumina Project, Vol. Technical Report #2.

Appendix A – Surveys

TEV Solar Lantern PRE-USAGE SURVEY:

Name of interviewer:

Date:

Time:

Location:

Subject ID:

Gender:

Age:

Household size:

1. What do you currently use as a source of lighting (kerosene, bulbs, batteries, matches, candles, etc.)?
2. Usage Time
 - a. For how many hours per day do use your current lighting source?
 - b. How many of these hours are in the morning and how many are at night?
3. Activity Usage
 - a. Which activities do you use your current lighting for typically?
 - b. Are there things that you like or dislike about your current lighting for those activities?
 - c. What do you like or dislike?
 - d. How would you describe the lighting for the following categories?
 - e. How many hours per day do you need lighting for each activity?
 - Reading
 - Cooking
 - General Illumination
 - Travel
4. Light Quality
 - a. How would you describe the quality of light that you currently have?

- b. Please comment on the brightness of the light.
 - c. Please comment on the steadiness of the light.
 - d. Are there other attributes that you would like to comment on? Please comment on them.
5. Mobility
- a. Do you move your lighting source?
 - b. For which activities do you move your lighting source?
 - c. How often per day do you move your lighting source?
 - d. How easy is the lighting source to move? What makes it easy or difficult?
6. Duration
- a. For how many hours does your current lighting source last?
 - b. How often do you purchase or collect [sources of lighting from earlier] for lighting per week?
 - c. How much [sources of lighting from earlier] do you purchase or collect at a time?
 - d. How far do you usually travel to purchase or collect more [sources of lighting from earlier] for lighting?
7. How difficult is it to light your current lighting source? Describe the process. About how much time does it take?
8. Overall, what are the things you like the most about your current lighting source?
9. What do you dislike the most about your current lighting source?
10. What would you do if you had more light?
11. How much do you spend on lighting per week?
12. Do you have access to electricity? If so, how many hours/day? How much do you spend on electricity per week?

TEV Solar Lantern POST-USAGE SURVEY:

Name of interviewer:

Date:

Time:

Location:

Subject ID:

The following survey is about the solar lantern that was provided for use over the past week.

1. Who was the primary user of the light?
2. For how many days did you use the light?
3. Usage Time
 - a. For how many hours per day did you use your light?
 - b. How many of these hours were in the morning and how many were at night?
4. Activity Usage
 - a. Which activities did you use your light for?
 - b. Are there things that you liked or disliked about your light for those activities? What did you like or dislike?
 - c. How would you describe the lighting for the following categories?
 - d. How many hours per day did you need lighting for each activity?

Reading

Cooking

General Illumination

Travel
5. Light Quality
 - a. How would you describe the quality of light from your solar light?
 - b. Please comment on the brightness of the light.
 - c. Please comment on the steadiness of the light.

d. Are there other qualities that you would like to comment on? Please comment on other qualities.

6. Mobility

- a. Did you move your light?
- b. If so, for which activities did you move your light?
- c. How often per day did you move your light?
- d. How easy was the light to move? What made it easy or difficult to move?

7. Duration

- a. For how many hours did your light last before you had to recharge it?
- b. Did the lantern provide light for a sufficient amount of time?
- c. How many times per week did you have to recharge the light?
- d. How easy was the solar light to charge?
- e. What made it easy or hard to charge?

8. Placement

- a. When your solar lantern was stationary, where did you place it?
- b. How easy was it to place your solar lantern where you needed it?
- c. What made it easy or difficult?
- d. After placing the lantern in a location, how easy was it to shine the light for your activities?
- e. Where would you place the light if you could place it anywhere?

9. How long does it take to turn on your light? Describe the process.

10. Overall, what are the things you like the most about the light?

11. What do you dislike most about the light?

12. What would you tell a friend about the light? Would you recommend it?

13. Would you buy one? If so, for how much?

14. Would you sell one?

**Technology Evaluation
Solar Lighting Survey**

TABLE OF CONTENTS

Section I: All Participants

1. Part I: Basic Information—Page 2
 Completed
2. Part II: Background—Page 2
 Completed
3. Part III: Lighting Usage—Page 3
 Completed
4. Part IV: Decision-Making Process—Page 4
 Completed
5. Part V: Characteristics of Light—Page 6
 Completed
6. Part VI: MaxDiff Questions—Page 7
 Completed
7. Part VII: Observation—Page 8
 Completed

SUBJECT ID: _____

Part I: Basic Information

[BI1]. INTERVIEWER: _____ [BI2]. SUBJECT ID: _____

[BI3]. DATE: ___DD ___MM ___YY [BI4]. TIME (0 - 24H): _____

[BI5]. CITY/TOWN: _____ [BI6]. COUNTRY: _____

[BI7]. GENDER: Male Female [BI8]. AGE (Approx.): _____

[BI9]. OCCUPATION: _____ [BI10]. MARITAL STATUS: _____

[BI11]. MEMBERS OF HOUSEHOLD: _____

[BI12]. PHYSICAL DESCRIPTION: _____

[BI13]. TYPE OF DATA COLLECTED: Interview/Observation Audio Recording
 Photographs Video Recording

Part II: Background

Can you walk me through a typical day for you? Do any of the activities require lighting? If yes, please explain.

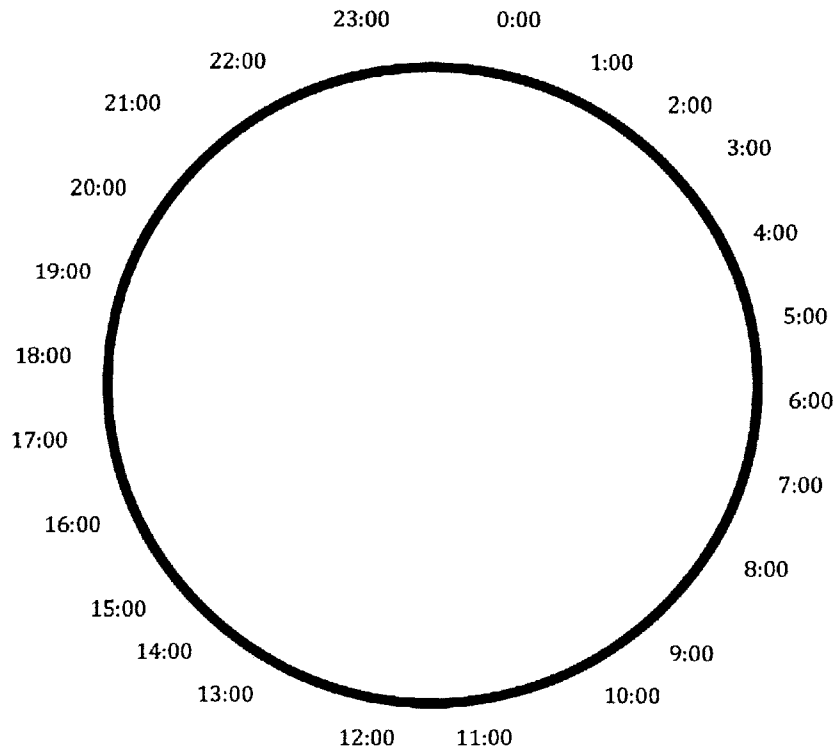

SUBJECT ID: _____

Part III: Lighting Usage

Fill out the table below by having a conversation about lighting usage. Start by asking *“Which activities do you use lighting for?”* and then mention specific categories if they are not addressed.

[LU1]. Activity	[LU2]. Current Sources of Household Lighting	[LU3]. Hours	[LU4]. Days Per Week
[A]. Cooking			
[B]. Social Interaction			
[C]. Outdoor Work			
[D]. Nighttime Security			
[E]. Walking at Night			
[F]. Reading/Studying			
[G]. Religious Purposes			
[H]. Retail			
[I]. Manufacturing			
[J]. Tending to Livestock			
[K]. Agriculture			
[L]. Preparing the Bed			
[M]. Other(s): Please Specify			

SUBJECT ID: _____

Part IV: Decision-Making Process

Address the following questions through the conversation these questions could be asked about their purchases of lighting devices over the past year or. Try to gather behavioral information for the period in which they can clearly recall their thought processes and actions.

DECISION STEPS		
[DMP1]. When did you realize that you needed to buy a light source or sources?	[DMP2]. Did you think about the type of light source(s) that you wanted?	[DMP3]. How many places did you go before choosing the light source(s)?
LAST PURCHASE FACTORS		
[DMP4]. What type of information did you need before making the decision to purchase a light source or sources?	[DMP5]. Who did you talk to or where did you get this information? And why are they a reliable source of information?	

SUBJECT ID: _____

[DMP6]. When you made the decision to purchase this light source(s) did you consider other options? How are they different from the light source(s) that you bought?			
[DMP7]. Which characteristics of light influenced your decision about which light source(s) to purchase?		[DMP8]. Why are these characteristics important?	
[DMP9]. If you need to buy something that you can't get here, how do you get it?			
LAST PURCHASE DETAILS			
[DMP10]. Who made the decision to purchase the light source(s) in your home?	[DMP11]. When was the last light source or sources purchased?	[DMP12]. How much did you pay for the light source(s)?	[DMP13]. Where was the light source purchased? How far away is that (if applicable)?

Part V: Characteristics of Light

Which characteristics of a light would you consider if buying a new light source?

Leave as an open-ended question-possible answers listed below. Check if mentioned, write details in space beside. Once the interviewee completes their response, ask about any characteristics on the list that were not mentioned.

- | | |
|---|--|
| <input type="checkbox"/> Durability [CL1]
(How long the light source lasts before breaking)
<input type="checkbox"/> Dust-Proof
<input type="checkbox"/> Rain/Water-Proof
<input type="checkbox"/> Insect Proof
<input type="checkbox"/> Resistant to Sun Damage
<input type="checkbox"/> Resistant to Hard Hits or Dropping | <input type="checkbox"/> Mobility [CL2]
(How easy the light source is to move around)
<input type="checkbox"/> Has a handle
<input type="checkbox"/> Is not heavy |
| <input type="checkbox"/> Charging or Replacement Time [CL3]
(How long it takes to recharge or replace sources such as batteries, fuel, etc) | <input type="checkbox"/> Charging Source [CL4]
(Where the new energy comes from) |
| <input type="checkbox"/> Aesthetics [CL5]
(How nice/beautiful the light source looks)
<input type="checkbox"/> Color
<input type="checkbox"/> Shape
<input type="checkbox"/> Material | <input type="checkbox"/> Size [CL6]
(How big or small the light source is)
<input type="checkbox"/> Big
<input type="checkbox"/> Medium
<input type="checkbox"/> Small |
| <input type="checkbox"/> Battery Life [CL7] (How long before there is a noticeable change in light quality) | <input type="checkbox"/> Weight [CL8]
(How much the light source weighs)
<input type="checkbox"/> Heavy
<input type="checkbox"/> Light |
| <input type="checkbox"/> Brightness [CL9] (How bright or dim the light source is) | <input type="checkbox"/> Has a Warranty [CL10] |
| <input type="checkbox"/> Placement [CL11]
(Where the light source goes)
<input type="checkbox"/> Ability to Hang
<input type="checkbox"/> Ability to Stand
<input type="checkbox"/> Ability to be Put in More than One Place
<input type="checkbox"/> Whether or Not it Tips Over | <input type="checkbox"/> Cost [CL12]
<input type="checkbox"/> Of Purchase
<input type="checkbox"/> Of Maintenance
<input type="checkbox"/> Whether or not it can be paid for over time |
| <input type="checkbox"/> Area Covered by Light [CL13]
<input type="checkbox"/> Lights an entire room
<input type="checkbox"/> Light can shine far | <input type="checkbox"/> Easily Repaired [CL14]
<input type="checkbox"/> Spare Parts are Available
<input type="checkbox"/> People Nearby Know How to Fix It
<input type="checkbox"/> I Can Fix It |
| <input type="checkbox"/> Whether It Has More Settings Than On and Off [CL15] | <input type="checkbox"/> Other: Please Specify [CL16] |

Part VI: MaxDiff Questions

In the following tables, please indicate which attributes are **MOST** important to you and which attributes are **LEAST** important to you when you consider becoming the owner of a light.
 Check **ONLY ONE** issue for each of the most and least columns, in each table.
 Each table will have one item ticked for the **MOST** preferred and one item for the **LEAST** preferred.

EXAMPLE: About Characteristics of Rice

LEAST IMPORTANT	CHARACTERISTIC	MOST IMPORTANT
X	Softness	
	Color	
	Size of Grain	
	Saltiness	X

[MD1].

LEAST	CHARACTERISTIC	MOST
	Charging Time	
	Battery Life	
	Ease of Repair	
	Water Resistance	

[MD2].

LEAST	CHARACTERISTIC	MOST
	# of Settings	
	How It Looks	
	Ease of Repair	
	Cost	

[MD3].

LEAST	CHARACTERISTIC	MOST
	Durability	
	Battery Life	
	Brightness	
	How It Looks	

[MD4].

LEAST	CHARACTERISTIC	MOST
	Charging Time	
	Mobility	
	How It Looks	
	Area Illuminated	

[MD5].

LEAST	CHARACTERISTIC	MOST
	# of Settings	
	Brightness	
	Area Illuminated	
	Water Resistance	

[MD6].

LEAST	CHARACTERISTIC	MOST
	Durability	
	Mobility	
	Water Resistance	
	Cost	

[MD7].

LEAST	CHARACTERISTIC	MOST
	Durability	
	# Of Settings	
	Battery Life	
	Mobility	
	Ease of Repair	
	Area Illuminated	

[MD8].

LEAST	CHARACTERISTIC	MOST
	Durability	
	Charging Time	
	Brightness	
	Ease of Repair	
	Area Illuminated	
	Cost	

[MD9].

LEAST	CHARACTERISTIC	MOST
	Charging Time	
	# Of Settings	
	Battery Life	
	Brightness	
	Mobility	
	Cost	

SUBJECT ID: _____

[MD10].

LEAST	CHARACTERISTIC	MOST
	Durability	
	Charging Time	
	# of Settings	
	Battery Life	
	How It Looks	
	Area Illuminated	
	Water Resistance	
	Cost	

[MD11].

LEAST	CHARACTERISTIC	MOST
	Battery Life	
	Brightness	
	Mobility	
	How It Looks	
	Ease of Repair	
	Area Illuminated	
	Water Resistance	
	Cost	

[MD12].

LEAST	CHARACTERISTIC	MOST
	Durability	
	Charging Time	
	# Of Settings	
	Mobility	
	How It Looks	
	Brightness	
	Ease of Repair	
	Water Resistance	

Part VII: Observations

Observe the users in their homes paying attention to the following:

[Ob1]. Others present during the observation (approximate age, gender, relationship, disabilities):		[Ob2]. Activities occurring during observation (interviewee or others):	
LIGHTS IN USE DURING OBSERVATION			
[Ob3]. Types of lights (including source)	[Ob4]. Number of lights	[Ob5]. Activities for lights	[Ob6]. Placement of lights

SUBJECT ID: _____

LIGHTS NOT IN USE DURING OBSERVATION			
[Ob7]. Types of lights (including source)	[Ob8]. Number of lights	[Ob9]. Placement of lights	
NATURAL LIGHT DURING OBSERVATION			
[Ob10]. Location of where natural light comes into the house		[Ob11]. Area that the natural light covers	
ELECTRICITY			
[Ob12]. Is the household connected to the electricity grid: <input type="checkbox"/> Yes <input type="checkbox"/> No		[Ob13]. If so, is it consistent: <input type="checkbox"/> Yes <input type="checkbox"/> No	
DIMENSIONS OF HOUSE			
[Ob14]. Length (In Meters)	[Ob15]. Width (In Meters)	[Ob16]. Height of Rooms (In Meters)	[Ob17]. Number of Rooms
[Ob18]. How does the house compare to other houses in the area in terms of amenities, general condition, etc:			

REACTIONS TO QUESTIONS OR CONVERSATION (VERBAL OR NON-VERBAL) OR OTHER NOTES, QUESTIONS, AND/OR INTERPRETATIONS:

SUBJECT ID: _____

THANK YOU FOR PARTICIPATING IN OUR SURVEY!!!

10

74

SUBJECT ID: _____

**Technology Evaluation
Solar Light Survey**

TABLE OF CONTENTS

Section II: Solar Light Recipients Only

1. **Part I: Solar Light Status—Page 2**
 Completed
2. **Part II: Solar Light Usage—Page 3**
 Completed
3. **Part III: Solar Light Questions—Page 4**
 Completed
4. **Part IV: Solar Light Rating Questions—Page 5**
 Completed
5. **Part V: Overall Satisfaction—Page 6**
 Completed
6. **Part VI: Observations—Page 7**
 Completed

SUBJECT ID: _____

Part I: Solar Light Status

[SLS1]. INTERVIEWER: _____ [SLS2]. SUBJECT ID: _____

[SLS3]. DATE: ___ DD ___ MM ___ YY [SLS4]. TIME (0 - 24H): _____

[SLS5]. CITY/TOWN: _____ [SLS6]. COUNTRY: _____

[SLS7]. GENDER: Male Female [SLS8]. AGE (Approx.): _____

[SLS9]. OCCUPATION: _____ [SLS10]. MARITAL STATUS: _____

[SLS11]. MEMBERS OF HOUSEHOLD: _____

[SLS12]. PHYSICAL DESCRIPTION: _____

[SLS13]. TYPE OF DATA COLLECTED: Interview/Observation Audio Recording
 Photographs Video Recording

[SLS14]. SOLAR LIGHT USED: The Firefly
 The Bogo Light
 The D. Light
 Other (Specify): _____

[SLS15]. Do you still have your solar light? <input type="checkbox"/> Yes <input type="checkbox"/> No	
[SLS16]. If yes, have you been using your solar light? <input type="checkbox"/> Yes <input type="checkbox"/> No	[SLS17]. If no, what happened to it?
[SLS18]. How long have you had your solar light?	
[SLS19]. Have you noticed any changes in the solar light since you received it? <input type="checkbox"/> Yes <input type="checkbox"/> No	
[SLS20]. If yes, what were these changes?	

Part II: Solar Light Usage

SUBJECT ID: _____

Fill out the table below by having a conversation about lighting usage. Start by asking about which activities people use lighting for and then mention specific categories if they are not addressed.

[SLU1]. Activity	[SLU2]. Current Sources of Household Lighting	[SLU3]. Hours	[SLU4]. Days Per Week
[A]. Cooking			
[B]. Social Interaction			
[C]. Outdoor Work			
[D]. Nighttime Security			
[E]. Walking at Night			
[F]. Reading/Studying			
[G]. Religious Purposes			
[H]. Retail			
[I]. Manufacturing			
[J]. Tending to Livestock			
[K]. Agriculture			
[L]. Preparing the Bed			
[M]. Other(s): Please Specify			

Part III: Solar Light Questions

SUBJECT ID: _____

REPLACEMENT OF LIGHT SOURCES		
<p>[SLQ1]. Did the solar lantern you used fully replace or partially replace existing light sources or did you use it in addition to your existing light sources?</p> <p><input type="checkbox"/> Fully Replaced</p> <p><input type="checkbox"/> Partially Replaced</p> <p><input type="checkbox"/> Used in Addition</p>		
<p>[SLQ2]. If fully replaced, what lighting sources did you replace?</p>	<p>[SLQ3]. If partially replaced, what lighting sources did you partially replace? How many hours less were you using them?</p>	<p>[SLQ4]. If used in addition to light sources, what activities did you use the solar light for?</p>
RECHARGING		
<p>[SLQ5]. Did you recharge the solar light?</p> <p><input type="checkbox"/> Yes</p> <p><input type="checkbox"/> No</p>		
<p>[SLQ6]. How many times per week did you recharge the solar light?</p>	<p>[SLQ7]. On average, how long did you let the lantern charge for?</p>	<p>[SLQ8]. Where did you recharge the light?</p>

Part IV: Solar Light Rating Questions

SUBJECT ID: _____

Please rate the following items of the solar light that you used. Please choose just one answer per item.

[RQ1]. Overall performance:

Very Poor	Poor	Average	Good	Excellent
1	2	3	4	5

[RQ2]. Battery Life:

Very Poor	Poor	Average	Good	Excellent
1	2	3	4	5

[RQ3]. Brightness:

Very Poor	Poor	Average	Good	Excellent
1	2	3	4	5

[RQ4]. Area Illuminated:

Very Poor	Poor	Average	Good	Excellent
1	2	3	4	5

[RQ5]. Cost:

Very Poor	Poor	Average	Good	Excellent
1	2	3	4	5

[RQ6]. Charging Time:

Very Poor	Poor	Average	Good	Excellent
1	2	3	4	5

[RQ7]. Ease of Repair:

Very Poor	Poor	Average	Good	Excellent
1	2	3	4	5

[RQ8]. Mobility:

Very Poor	Poor	Average	Good	Excellent
1	2	3	4	5

[RQ9]. Durability:

Very Poor	Poor	Average	Good	Excellent
1	2	3	4	5

[RQ10]. Water Resistance:

Very Poor	Poor	Average	Good	Excellent
1	2	3	4	5

[RQ11]. How It Looks:

Very Poor	Poor	Average	Good	Excellent
1	2	3	4	5

[RQ12]. Number of Settings:

Very Poor	Poor	Average	Good	Excellent
1	2	3	4	5

Part V: Overall Satisfaction

SUBJECT ID: _____

LIKES	
[OS1]. What do you like MOST about the solar light?	[OS2]. Why?
DISLIKES	
[OS3]. What do you like LEAST about the solar light?	[OS4]. Why?
[OS5]. Is there anything that you would change about the light? <input type="checkbox"/> Yes <input type="checkbox"/> No	

SUBJECT ID: _____

<p>[OS6]. If yes, what would you change?</p>
<p>[OS7]. Is there anything else that you would like to say?</p>

Part VI: Observations

Observe the users in their homes paying attention to the following:

<p>[Ob1]. Others present during the observation (approximate age, gender, relationship, disabilities):</p>	<p>[Ob2]. Activities occurring during observation (interviewee or others):</p>
--	--

SUBJECT ID: _____

LIGHTS IN USE DURING OBSERVATION			
[Ob3]. Types of lights (including source)	[Ob4]. Number of lights	[Ob5]. Activities for lights	[Ob6]. Placement of lights
LIGHTS NOT IN USE DURING OBSERVATION			
[Ob7]. Types of lights (including source)	[Ob8]. Number of lights	[Ob9]. Placement of lights	
NATURAL LIGHT DURING OBSERVATION			
[Ob10]. Location of where natural light comes into the house		[Ob11]. Area that the natural light covers	
ELECTRICITY			
[Ob12]. Is the household connected to the electricity grid: <input type="checkbox"/> Yes <input type="checkbox"/> No		[Ob13]. If so, is it consistent: <input type="checkbox"/> Yes <input type="checkbox"/> No	

SUBJECT ID: _____

DIMENSIONS OF HOUSE			
[Ob14]. Length (In Meters)	[Ob15]. Width (In Meters)	[Ob16]. Height of Rooms (In Meters)	[Ob17]. Number of Rooms
[Ob18]. How does the house compare to other houses in terms of amenities, general condition:			

REACTIONS TO QUESTIONS OR CONVERSATION (VERBAL OR NON-VERBAL) OR OTHER NOTES, QUESTIONS, AND/OR INTERPRETATIONS:

SUBJECT ID: _____

Stage I: Part I: Basic Information

[B11]. INTERVIEWER: _____ [B12]. SUBJECT ID: _____

[B13]. DATE: ___DD ___MM ___YY [B14]. TIME (0 - 24H): _____

[B15]. CITY/TOWN: _____ [B16]. COUNTRY: _____

[B17]. GENDER: Male Female [B18]. AGE (Approx.): _____

[B19]. OCCUPATION: _____ [B110]. MARITAL STATUS: _____

[B111]. MEMBERS OF HOUSEHOLD: _____

[B12]. TYPE OF LANTERN: _____ [B13]. HOW MANY LANTERNS
PURCHASED BEFORE THIS ONE? _____

[B112]. TYPE OF DATA: Photo Release Audio Recording

Part II: Background

Can you walk me through your typical day? Do any activities require lighting? If yes, please explain.

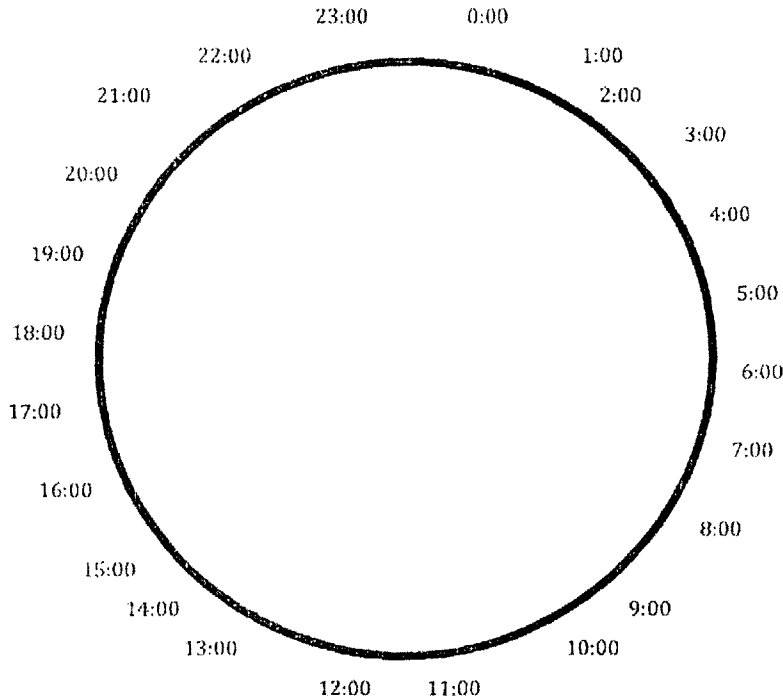

Part III: Lighting Usage

Follow on from the conversation about a typical day.

OTHER LIGHTING SOURCES		
[LU1]. What sources of light (besides a solar lantern) do you use? For which activities do you use these sources?		
LIGHT USAGE		
[LU2]. Have you been using your solar light? <input type="checkbox"/> Yes <input type="checkbox"/> No	[LU3]. If no, what happened to it?	
[LU4]. Have you noticed any changes in the solar light since you received it? <input type="checkbox"/> Yes <input type="checkbox"/> No		
[LU5]. If yes, what were these changes? Did you need any repairs? If so, what type of repairs and how long did they take?		
RECHARGING		
[LU6]. Do you recharge the solar light? <input type="checkbox"/> Yes <input type="checkbox"/> No		
[LU7]. How many times per week do you recharge the solar light?	[LU8]. On average, how long do you let the lantern charge for?	[LU9]. Where do you recharge the light?
[LU10]. Do you use the solar lantern to charge your phone? <input type="checkbox"/> Yes <input type="checkbox"/> No	[LU11]. How many times per week do you use it to charge your phone?	[LU12]. On average, how long do you let your phone charge for?

SUBJECT ID: _____

Part IV: Decision-Making Process

Address the following questions through the conversation. These questions should be asked about their last purchase of a solar lantern. Try to gather behavioral information for the period in which they can clearly recall their thought processes and actions.

DECISION STEPS	
[DMP1]. What made you realize that you needed to buy a solar lantern?	
LAST PURCHASE FACTORS	
[DMP2]. What type of information did you need before making the decision to purchase a light source or sources? Who did you talk to or where did you get this information? And why are they a reliable source of information?	
[DMP3]. When you made the decision to purchase this light source(s) did you consider other options? How are they different from the light source(s) that you bought? How many places did you go?	
LAST PURCHASE DETAILS	
[DMP4]. Who made the decision to purchase the light source(s) in your home?	[DMP5]. When did you purchase the lantern?
[DMP6]. How much did you pay for the light source(s)?	[DMP7]. Where was the light source purchased? How far away is that (if applicable)?
[DMP8]. Which characteristics of light influenced your decision about which light source(s) to purchase? Why?	

SUBJECT ID: _____

Part VI: MaxDiff Questions

EXAMPLE: About Characteristics of Rice

LEAST IMPORTANT	CHARACTERISTIC	MOST IMPORTANT
X	Softness	
	Color	
	Size of Grain	
	Saltiness	X

[MD1].

LEAST	CHARACTERISTIC	MOST
	Charging Time	
	Battery Life	
	Ease of Repair	
	Water Resistance	

[MD2].

LEAST	CHARACTERISTIC	MOST
	# of Settings	
	Phone Charging	
	Ease of Repair	
	Cost	

[MD3].

LEAST	CHARACTERISTIC	MOST
	Durability	
	Battery Life	
	Brightness	
	Phone Charging	

[MD4].

LEAST	CHARACTERISTIC	MOST
	Charging Time	
	Mobility	
	Phone Charging	
	Area Illuminated	

[MD5].

LEAST	CHARACTERISTIC	MOST
	# of Settings	
	Brightness	
	Area Illuminated	
	Water Resistance	

[MD6].

LEAST	CHARACTERISTIC	MOST
	Durability	
	Mobility	
	Water Resistance	
	Cost	

[MD7].

LEAST	CHARACTERISTIC	MOST
	Durability	
	# Of Settings	
	Battery Life	
	Mobility	
	Ease of Repair	
	Area Illuminated	

[MD8].

LEAST	CHARACTERISTIC	MOST
	Durability	
	Charging Time	
	Brightness	
	Ease of Repair	
	Area Illuminated	
	Cost	

[MD9].

LEAST	CHARACTERISTIC	MOST
	Charging Time	
	# Of Settings	
	Battery Life	
	Brightness	
	Mobility	
	Cost	

[MD10].

LEAST	CHARACTERISTIC	MOST
	Durability	
	Charging Time	
	# of Settings	
	Battery Life	
	Phone Charging	
	Area Illuminated	
	Water Resistance	
	Cost	

[MD11].

LEAST	CHARACTERISTIC	MOST
	Battery Life	
	Brightness	
	Mobility	
	Phone Charging	
	Ease of Repair	
	Area Illuminated	
	Water Resistance	
	Cost	

[MD12].

LEAST	CHARACTERISTIC	MOST
	Durability	
	Charging Time	
	# Of Settings	
	Mobility	
	Phone Charging	
	Brightness	
	Ease of Repair	
	Water Resistance	

SUBJECT ID: _____

Stage II
Part I: Basic Information

[BI1]. INTERVIEWER: _____ [BI2]. SUBJECT ID: _____

[BI3]. DATE: ____DD ____MM ____YY [BI4]. TIME (0 - 24H): _____

[BI5]. CITY/TOWN: _____ [BI6]. COUNTRY: _____

[BI7]. GENDER: Male Female [BI8]. AGE (Approx.): _____

[BI9]. TYPE OF DATA COLLECTED: Photographs Audio Recording

Part II: Specific Solar Light Usage

Fill out the table by having a conversation about the **specific solar lantern's usage within the past 7 days (1 week)**. Start by asking about which activities households used the specific lantern for and then mention the listed categories if not addressed. Ask how many times the activity happened in the past week, and then how long the activity lasted. Ask if any activities happened at the same time.

[SLU3]. Activity	[SLU4]. Days /wk	[SLU5]. Hours/day	[SLU6]. Notes
[A]. Cooking			
[B]. Social Interaction			
[C]. Outdoor Work			
[D]. Nighttime Security			
[E]. Walking at Night			
[F]. Reading/Studying			
[G]. Religious Purposes			
[H]. Retail			
[I]. Preparing the Bed			
[J]. Tending to Livestock			
[K]. Agriculture			
[L]. Other(s):			
[M]. Other(s):			

SUBJECT ID: _____

<p>[SLU1]. Did you notice any differences between the instrumented solar lantern and your original lantern?</p>	<p>[SLU2]. Who used the solar lantern within the last week?</p>
---	---

Part III: Overall Satisfaction

LIKES	
<p>[OS1]. What do you like MOST about the solar light?</p>	<p>[OS2]. Why?</p>
DISLIKES	
<p>[OS3]. What do you like LEAST about the solar light?</p>	<p>[OS4]. Why?</p>
<p>[OS5]. Is there anything that you would change about the light? <input type="checkbox"/> Yes <input type="checkbox"/> No</p>	
<p>[OS6]. If yes, what would you change?</p>	
<p>[OS7]. Is there anything else that you would like to say?</p>	