

The object
as a vessel
for Vitality:
A Design
Methodology

by Allan David Schwarz
Bachelor of architecture
University of the Witwatersrand
Johannesburg, South Africa
1980

Submitted to the Department of Architecture in partial fulfillment
of the requirements of the degree Master of Science in Architecture
Studies at the Massachusetts Institute of Technology.

JUNE, 1988

(c)Allan David Schwarz, 1988 The Author hereby grants to M.I.T permission
to reproduce and to distribute publicly copies of
this thesis document in whole or in part.

Signature of the author

Allan David Schwarz
Department of Architecture
May 12, 1988

Certified by

Edward Robbins
Lecturer, Department of Architecture
Thesis supervisor

Accepted by

Julian Beinart
Departmental Committee for Graduate Students
Department of Architecture

1

MASSACHUSETTS INSTITUTE
OF TECHNOLOGY
JUN 3 1988
Rotch LIBRARY

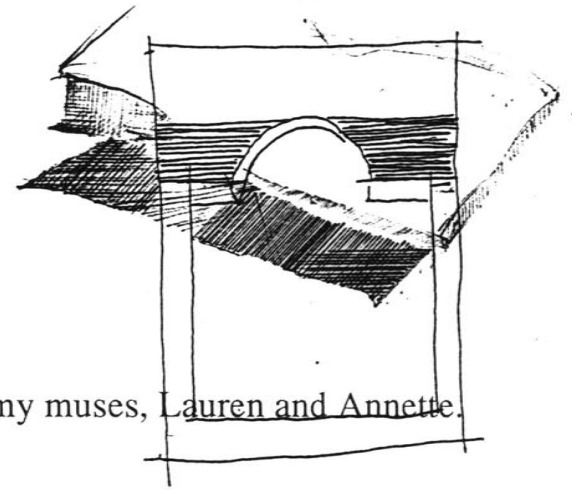
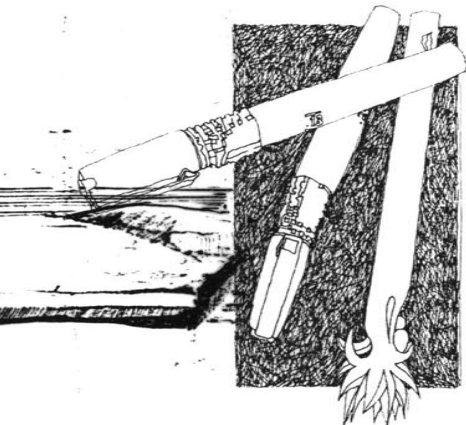
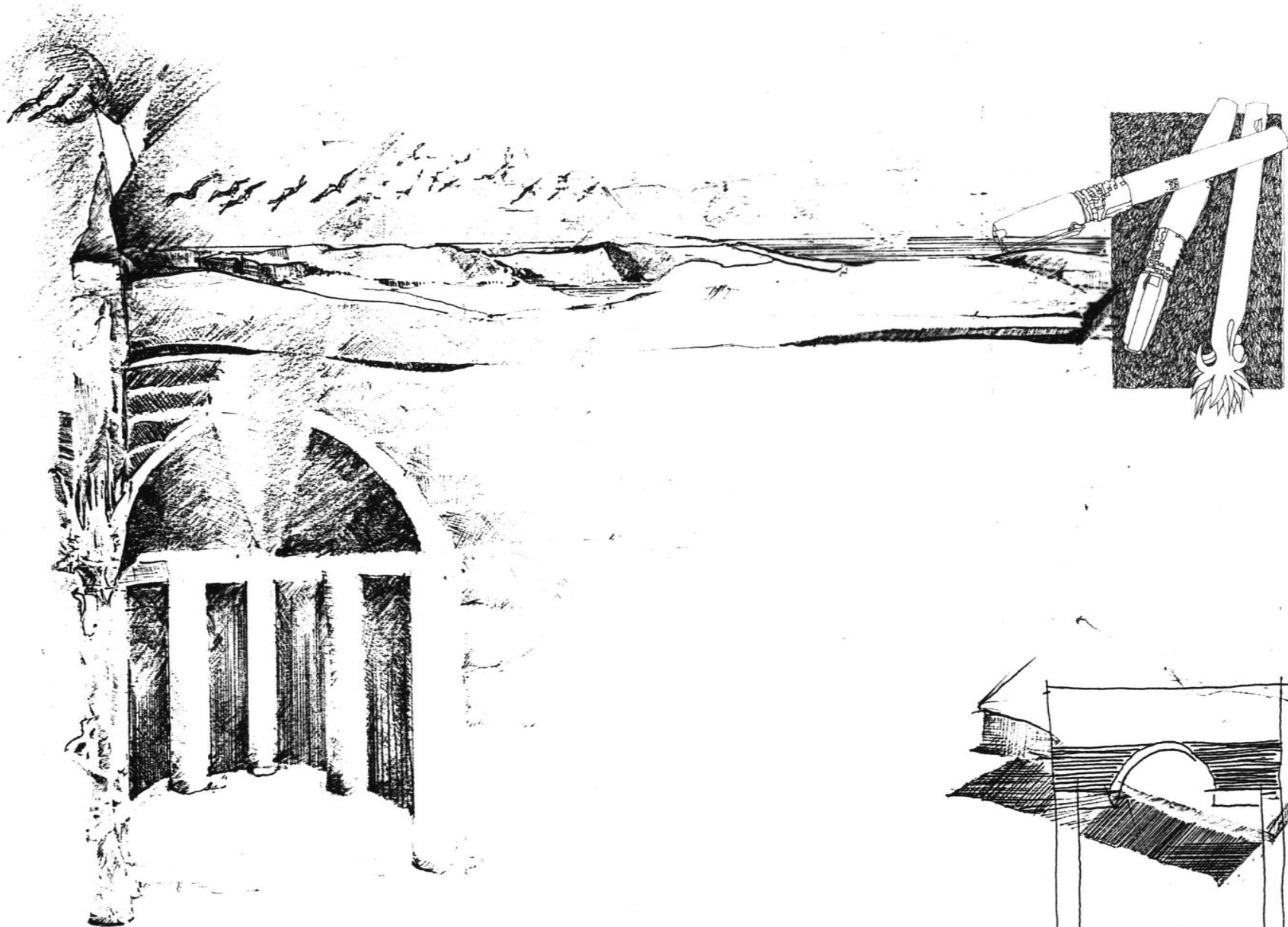

for my muses, Lauren and Annette.

The object as a vessel for Vitality:A Design Methodology

by Allan David Schwarz

Submitted to the Department of Architecture on May 13, 1988 in partial fulfillment of the requirements of the degree Master of Science in Architecture Studies at the Massachusetts Institute of Technology.

Abstract

"To Build,form blocks, like a ladder into the sky, into the Earth,to bind the elements, Water and Fire".

Like Wittgenstein's this is an attempt to define a personal methodology, which when documented and left behind might help others along a similar path of exploration.

I began in an art museum, examining the artifacts of old cultures,Their usable objects which are assumed of "Museum Quality",they were chosen by virtue of being either more desirable than others, having survived the years where others have not,the only pieces left, or for having some special appeal which the others didn't have.

It is assumed that they are a reflection of the cultures that they represent, and from them we can deduce the nature of the society which made them.

What is the nature of the society that we act in? and how do the objects around us reflect it?What is the nature of the society that we desire? can the making of objects reflecting that desire affect the reality of society and change it,even if only a little, towards what we believe to be desirable?What are the issues of design and production which may have this effect?

This is then an attempt to explore some of those issues, and to test them through designing, making and using some special objects.

Thesis supervisor: Edward Robbins

Title:Lecturer,Department of Architecture

Acknowledgements

Producing a thesis would not have been possible without the space and encouragement to explore which is at the root of M.I.T.'s philosophy. Within that system, it becomes increasingly apparent that the chief resource here is the students, whose backgrounds, and interests are so diverse as to provide the answers to almost any questions which arise. And to have had them available I am most grateful.

I would like to express my appreciation for the staff at the C.A.V.S., and particularly thank my fellow Fellow Joe Davis for his constant encouragement and inspiration.

Also, thanks to Otto Piene for the space and encouragement he has given me as a Fellow at the center.

Similarly, Chris Dewart at the woodshop has unflinchingly provided space and advice throughout this process.

Ed Robbins, my advisor, mentor and friend for just being that.

And finally, Maria De Angelis, who rescued me from the morass of words, with Lauren Weingarten for her help with drawings, photographs, and constant inspiration.

How to Read the Thesis



It consists of two columns of thoughts, the right hand side of the page, a documentation of various design/making/use experiments, abstracted from note books, sketches, technical drawings, models, mock ups and finished products, as well as user reviews. I guess that these form what would usually appear as appendices to a thesis, but as they are so closely related to the essays on the other side of the page, they need to be right there.

The essays on the left, comprise a series of principles largely extrapolated from the hands on work, invented, or produced to clarify the ideas in preparation, or extracted from the thinking of others. occasionally a drawing or two takes over more than its allotted side of the page.

Table of contents

1.Abstract	3		
2.Acknowledgements	4		
3.How to Read the Thesis	5		
4.Table of contents	6		
5.Left hand side		Right hand side	
A. Design, Art, and Life	7	G.Introduction	7
B. The Meaning of Work	13	H.Marble Hand Sculpture	8
C. Relation of Nature to Self	18	J. A Stair Story	12
D. Nature of the Object	29	K.Sky Cloths	19
E. The ritual of Design Through Making	33	L.An Observatory Campus	22
F.Choosing Things to Make	44	M.On Miro	30
		N.Star Pictures	33
		P.Star Sphere	43
		Q.Snow sculpture	45
		R.Dies	51
		S. Suiseki Boxes	57
		T.Work Table	61
		U.Crit Stool	63
		V.Cutting board	66
		W.Home Suite	67
		X. Music Stand	72
6.Conclusion	77		
7.Bibliography	81		

But in every single work he particularly verifies and lucidly demonstrates his basic assumption, that those things most concerned with Architecture are those which refer to it least. It is as though he has discovered a set of hidden laws of architecture which underlie everything and to which everything relates. - on Massimo Scolari.

Design, Art, and Life

At the root of every maker's introspection lies the query: What motivates me to design? in every act of design, art, architecture- which are essentially inseparable- is implicit an utterly personal, usually intangible sense of yearning and doubt. to explore these questions and this unspoken wish is the task at hand.

First, some assumptions must be made. That design and art are very closely related is no mystery to anyone, I furthermore believe that design and art are largely inseparable. Both are interrelated manifestations of our lives desires, and both are records of how we actually live. Basic to our desire to make things are our aspirations for life. Especially, perhaps, in architecture, where we are making places to live and work (I do not mean to

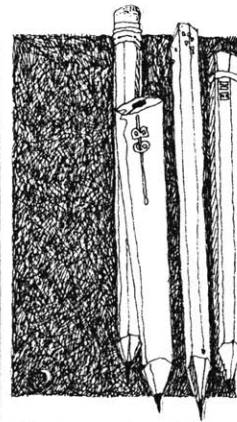

Introduction

All the projects included here are at scales of either hand held objects, or small items of furniture, which assemble into "roomscales" and from which landscapes and buildings can be fantasied.

imply a separation here), our desires, from the most elemental to the most spiritual, are made explicit. These desires range from the level of animal need- survival, shelter, comfort- to more human need - sense of self, relationships with one's immediate world- to man's highest yearnings- a connection with the cosmos. So design and art- perhaps formulating and making aspects of the same act- are one with the life of the maker, in that they reflect the artist's wishes for life and the circumstances of how he actually lives.

Next, we may focus on the act of making itself. When one makes something, it is a final act in itself. Whether the thing made is a sketch, a maquette, or a full-scale building, it is final in that it is the last thing made. Seen in this state of completion, it deserves an intensity in making. Since each thing done is directly related to the way the maker wants to live, each object somehow aids and clarifies his aspirations. Yet the very fact that the object aids his dreams implies a sense of continuity, a knowledge that further steps toward self-realization must be made. There is inevitably conflict between, on the one hand, the completion of each object in and of itself, and on the other this sense of more doors opening upon its completion, that actually one is

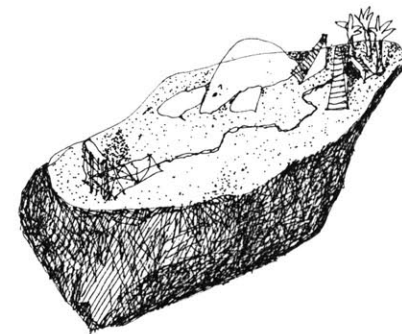

Marble Hand Sculpture

I recall in the desert, a good few years ago finding a stone age hand axe, I picked it up thinking it was just another stone but it fitted into my hand so naturally, that I decided to keep it, and later when I cleaned it, discovered it to be a wonderfully crafted object. The energy of the men who made and used it, many years later, still seeps into my palm when I hold it.

never truly finished. The positive aspect of this is that the open doors lead always to further exploration. at the very least, the made object has continuity with its intended (or unintended) use. And this continuation is only possible as a carryover of the intensity demanded in the object's making.

Thus the third assumption concerns the Zen notion that the care and intensity with which you make is both carried by the object and is felt by the person using it. We can speak of the making and drinking of tea as an example of this. In Britain, where tea-time is in some sense a regulator of the everyday life of people, the way tea is made and the vessels out of which it is drunk is also of the ordinary, reflecting the normalising ritual. While there is some ceremony attached to making tea, much like daily prayers. Likewise British teacups are sturdy durable and mass produced. In Japan, on the other hand, the tea ceremony is a highly ritualized individual event. It takes an ordinary event and makes it superordinary, with attendant dances, coquetteries, etc. Teacups in Japan are handmade, one of a kind, and utterly refined to match this ceremony. So in this example we see that the object or artifact, the teacup, is a record of ritual and in

I also remember as a boy splitting open agates in the hope that they were geodes, and contained crystals, or magic.

I was given a compass, a tool for orientation, a way of finding ones self and not getting lost, through lines of site, from this little piece of the earth, to a distant star, maybe just maybe, I can link the earth with the sky and me.



some sense an indicator of the life of the people. Likewise archaeologists speculate on what life was like in past civilizations from the artifacts left behind.

To return to design and art, the making of these usable artifacts then becomes not just an end in itself, but actually refers to living. The objects one makes indicate how one would like to live. Just as dramatic theatre is an intensification of human behavior, design is an intensification of the way you live. Theatre takes human actions and exaggerates them for the purpose of eliciting essential meanings from them. Design and art likewise makes an exaggerated statement for the purpose of demanding to live life in a certain distilled way. Thus a designed object is a record of intensified life.

A designer may have the technical skills to provide for the animal needs- shelter and survival. Furthermore he may have the sensitivity to provide for physical comfort. Yet this is not enough: to be a designer who strives for excellence, one must connect with the cosmos and in some way, religious

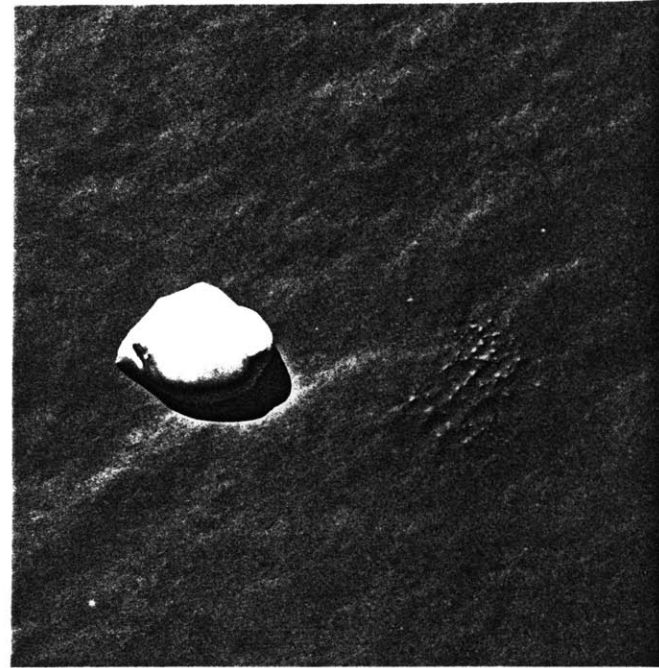

meaning. If he wants objects, he must know life's rituals and his life's desires. Only this struggle for knowledge, in sense living well, produces the ability to make good objects.



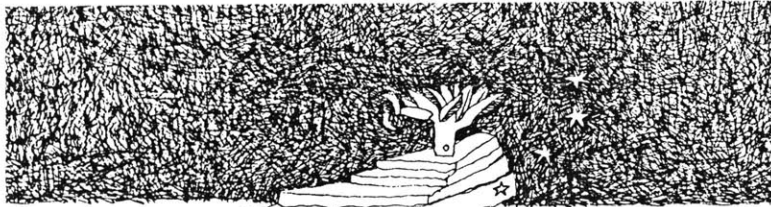

A Stair Story

A man looked up at the sky, and saw some stars gathering together in an angelic constellation, and desired to reach up to those stars, to touch them, and have them touch his life. Like a Kepler horoscope, cast in his own image, he remembered Babel, Babalon, and how he looked up at the sky when he first left an underground train, walking up stairs, channeling his view of the sky.

The first steps, a few, just four to be on a special platform, to get a little closer to the stars. He stopped and looked at these new stars and how they gathered together to form a wing in the sky, and in earnest started to build steps to the stars.

One by one he laid the stones, step at a time, soon it was too high to walk back to the ground to collect a new stone to hew and lay it another step higher into the sky, so he took one from halfway down, and placed it at the top of the flight. Then went down again, and picked up another middle stone, and again laid it at the top. Then scurried between the top few stairs, lifting stones and laying them, lifting and laying, until he flew away on his stone stairs to the angelic constellation.

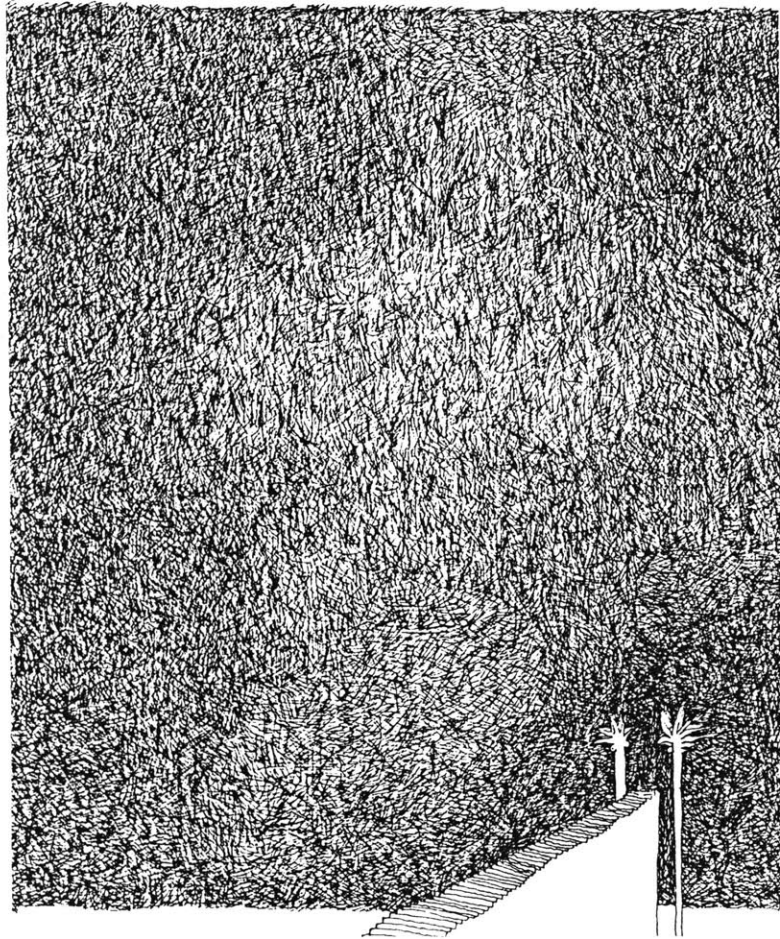

The Meaning of Work

We begin from the theory of existence proposed by E.F.Schumacher in his Guide to the perplexed. Here our own existence builds from an inanimate, mineral state through the plant state to animal and finally to human existence. Schumacher proposes that as you transcend one state, you master the problems endemic to it. That is, in ascending to a higher level the realities of the lower level left behind are mastered, realized or owned.

Now we imagine a conversation taking place between Hephaestus, the Olympian craftsman, and Socrates, gadfly of society, elucidator of difficult questions.

Hephaestus: What came ye here for, mortal? Trouble with the architects again, not knowing whether they're meant to be craftsmen or intellectuals?

Socrates: No, Great God; it seems there is a conflict between materials and spirituality. Those who call themselves ascetics and artists feel they must operate amaterially, that in order to approach spirituality they must abrogate their hold on the

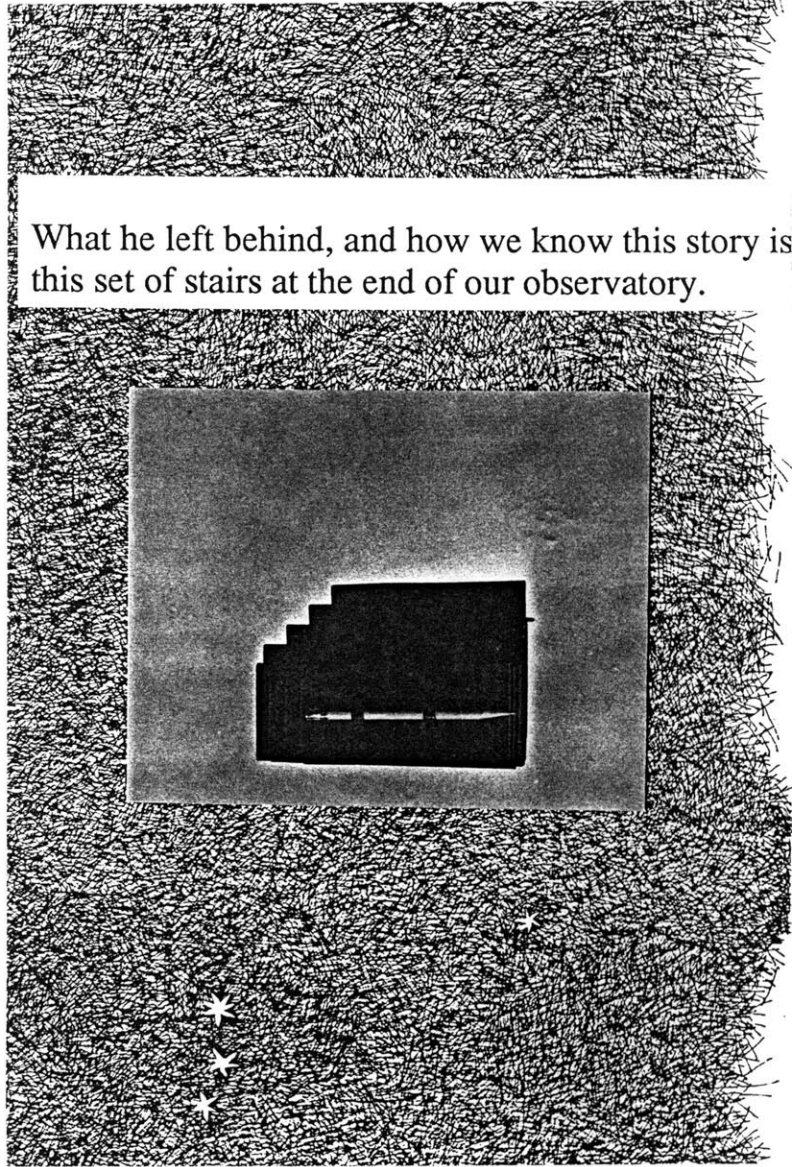

What he left behind, and how we know this story is this set of stairs at the end of our observatory.

goods of this world.

Hephaestus: And yet these artists are craftsmen like myself, and thus must deal directly with the material. Material is in fact their medium for spirituality, their only hope of transcendence.

Socrates: How can this be, if all the great spiritual masters warn against being bound to materialism?

Hephaestus: The answer lies in the transcendence of the material. Only in mastery of the material upon which he works can the artist or designer approach spirituality. And mastery can be sought through care in making. The greater the participation of the maker in all decisions connected making, the greater the possibility of transcending the material. There must be a constantly caring conversation between craftsman and his material.

Socrates: How could this dialogue occur? is it possible for a material to speak to its worker?

Hephaestus: It is indeed. A craftsman may force his intentions, or a design on a piece of timber, for example, The result is that the wood appears as if it

Pencil Box

At the same time as all this dreaming, I bought a very expensive piece of wood, Purple Heart, and decided, as it was my first project to be done in the Workshop and in all vanity, that I had to prove my craftsmanship and make an object of real beauty and refinement.

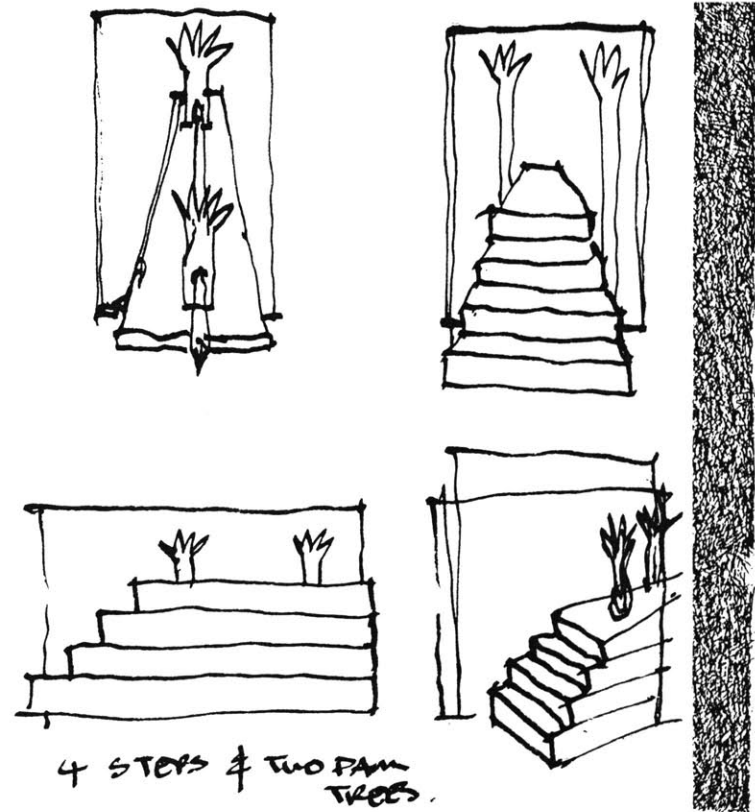

had been damaged. Its structure won't allow it to be worked against the grain so to speak. Whereas if, from the time he selects a piece of timber, the craftsman is open to and observant of what the material has to tell him,.....the result is far more synergetic.

Socrates: Could the artist then select a piece with no particular end in mind, and let the wood craft itself into what it wanted to be? Or would he select a piece which was appropriate to the use he has in mind?

Hephaestus: Either mode of selection is acceptable. The latter is more often the case for work which has a utilitarian intent. It is, however, of greater importance to "own" this selected piece.

Socrates: Assuming he has chosen a bit of material upon which to work, how can the craftsman make it his own, or somehow be the master of the thing he is making?

Hephaestus: Each workman must have a sense of leaving his mark and take responsibility for it. His hands, his tools are what enables him to leave his mark, and are thus most precious. These tools are what enable an artist to connect with the cosmos, by



The problem was however that while this can be planed and done, it kind of makes the box precious and quite resolved and static, in contrast to the later boxes, where the process of making and designing were not separated. Very little in the producing of the first box could inform its own design, as this was already established. The wood, the tools, the craftsman so to speak, had no say in the matter of the end products, but doing their production job properly, and leaving their mark exactly as specified, to do this with objects more complex in design and larger in scale would require an inordinate pre-knowledge of all the factors to take into account in order to pre-plan them as well as contingency planning for all the problems that might arise. If anything of value was learned it was that while this design process might produce beautiful objects, that's where it ends, and a little lost I deviated in a whole lot of other directions.

allowing him to make a mark in it. Remember that these tools are also crafted objects and carry with them the fineness of their making.

Socrates: And thus each craftsman is tied individually to the cosmos through his ritualized work? There is one school of thought which holds that a craftsman may not divide his work on his object because it removes a sense of the whole and confuses his sense of possession. The full benefit of the work is lost in diffusion among different makers.

Hephaestus: On the contrary, the world of mortals has become so complicated and therefore so specialized that in order to achieve mastery of his craft a man may perform only one kind of work while sharing in a vision of the whole process.

Socrates: How then can complex works be made well if the craftsman is only going to pass it along to another to do further work on it?

Hephaestus: The intensity of the object can be read by each successive worker and its user. The craftsman who begins the work invests a certain energy or integrity in the work. This is carried

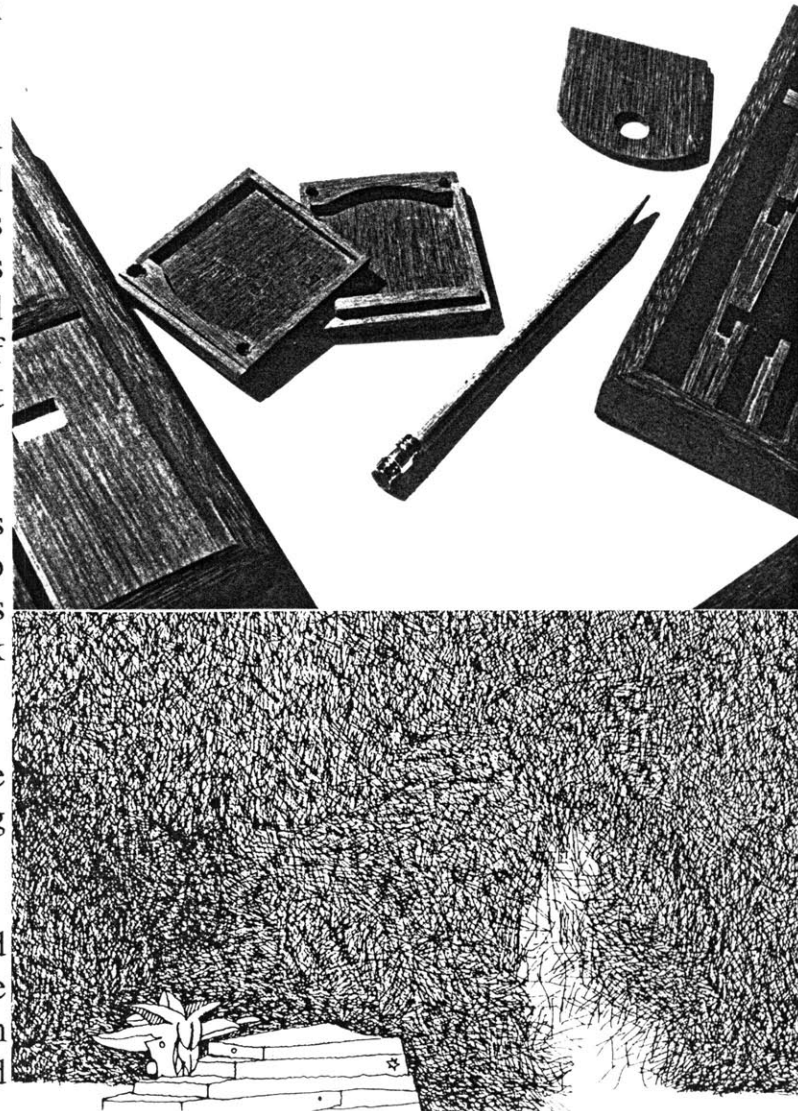

through the object to the next craftsman, who adds his own intensity to the energy already invested. This continues until the object, reaches the user. The user, like each successive craftsman, can then read the energy in the object, and this is what gives it greater value.

Socrates: So if a designer sits and draws, he produces an object. If it contains readable vitality, then the worker making a mockup of the object drawn should be able to feel that intensity, participate with his own sense of energy recording his possession of the object by making his mark in its production, passing it to the die-maker who now has the sum of the previous two participants energy in the objects he receives and the entire process becomes a cumulative ritual, without loss of integrity at any stage in the process. The issue is that each stage should compliment, not compromise the others.

Hephaestus: In this sense the design and the execution of work has a major sense of identity with one's sense of place.

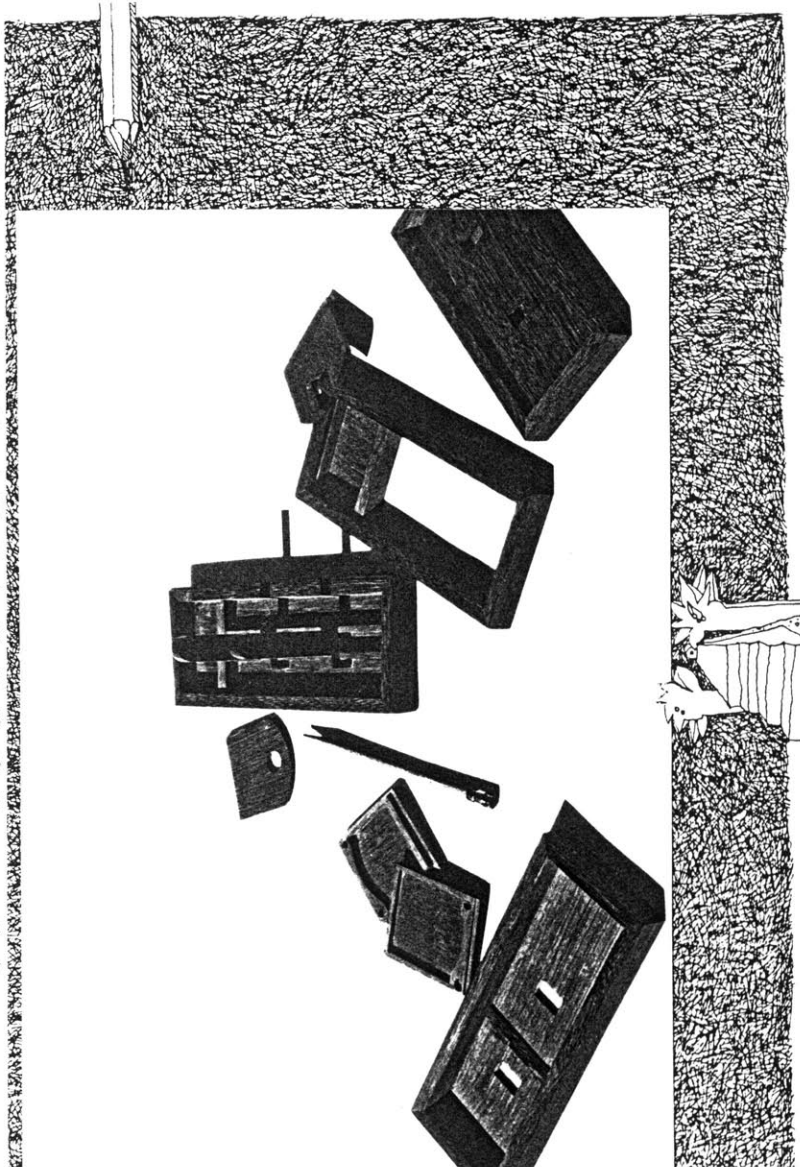

Relation of Nature to Self

We learn, that at the base of our existence is our presupposition of how we relate to the cosmos. Our approach to life - religious, cultural, and scientific - is rooted in this initial statement of our relationship to nature and to higher powers. One example of this idea can be seen each time we visit any museum of art and cultural history. Precious objects which have survived from ancient civilizations are decorated so as to depict the essence of religious icons. All of these objects explain the artists' -and through them the culture's - relationship with some higher level of existence.

Taking this example further, we can imagine trying to collect the precious items from our own era, in fact to define in a formal way those icons which connect us to the cosmos. We would be sadly faced with an oversaturation of media images, and a very thin link with our origins. The current trend is to relate to the cosmos in scientific terms .We herald as the new messiahs those aero-astrophysicists who came up with quantitative answers to the questions of the universe. Forgetting Wittgenstiens epilogue, where he states that it doesn't mean as much to resolve the formal questions as he did but what you



then do with it. The mythology of explanation is left up to religion, and, failing that, a few cranky artists, to determine. Few people seem to listen to these new alchemists.

In their book *Powers of Ten*, the Morrisons' and the Eamses' suggest that the cosmos is not only definable in terms of our relations to the stars, but actually starts with our relationship to each other, on a one-to-one scale. This interpersonal relationship can expand by powers of ten, they argue, to our relations with our immediate ecosystem, with the earth system, the solar system, the galaxy, and eventually with distant stars. These initial one-on-one relations can conversely shrink in scale to our relationships with smaller beings, with microbes, and with atoms. So our relationship to the cosmos can become bigger or smaller based on our initial relations with one another.

To return to the question of how cosmological ties are reflected in artifacts, we can discern two ways in which relationships are recorded in our making. Relationships which tend to grow outward are reflected in pattern-making: imagery, labeling, amazingly stars into constellations, and so on. We

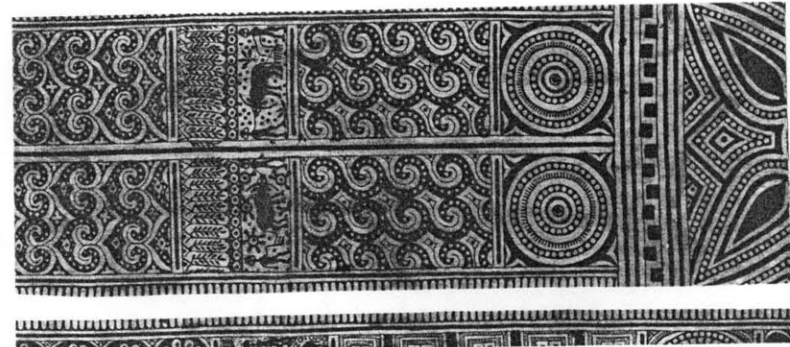

Sky Cloths

This Indonesian stuff is quite fascinating, really makes me want to go there and look around, maybe even live there for a little while, these cloths, in which the iconography of all their decorative elements that are in all their buildings and crafts appear out of every day living, around which legends and myths are generated, illustrated and from them again their cosmology. They seem in a lot of ways really primitive, and direct, but when examined closely, they are remarkably refined. Simple cloth, cotton, plain flat weave, then painted, stamped, dyed, drawn on in layer upon layer of work, producing exceptional subtlety of color, and form. The spaces between what at first seem to be regular patterns of repeated elements are not regular, and create wonderful fields of form and shape. anyway I need to let this stuff soak in, and feel its going to be useful.

then assume that these patterns have an effect because of the meaning we have invested in the arrangement of them. In former times, men invented myths to explain these applied patterned phenomena in religious terms.

Relationships which grow inward, conversely, first take the myths, and create them in things smaller than ourselves. For example, the Mayan civilization recognized a Frog constellation of stars. While the image was drawn from a lower form of life, in being elevated to the level of the distant stars it was imbued with the power to control the rain. Rain being a very rare, and thus precious commodity in that civilization, a myth was created to protect it. Coming full circle, the Mayans then turned back to the real embodiment of this symbol, the frog, and worshipped it as a symbol of good fortune. Their amulets, charms, and special occasion items such as cups directly depict the frog to bring them this luck.

The problem pointed out by this example is that the symbol or essence of the icon tends to become

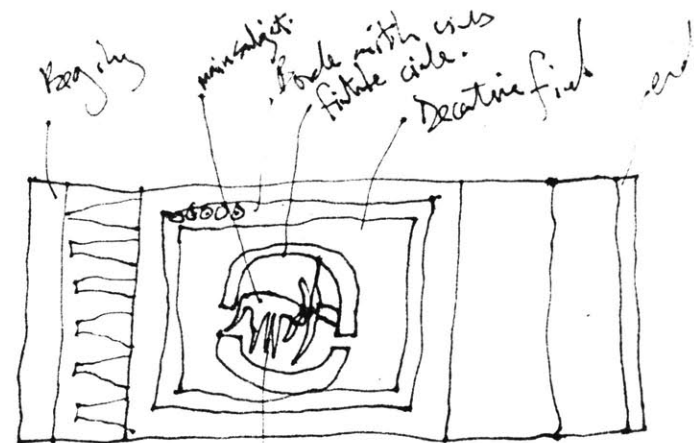

Legend or direct relation to life.

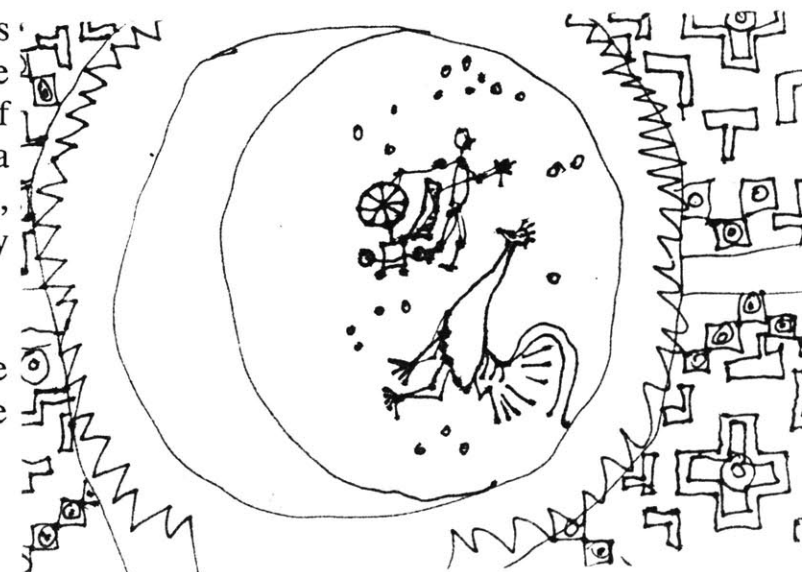

illustrative. It is so indirectly related with our own experience and relationships that it actually ceases to contain either the myths or the reality of myths. Perhaps the answer to this problem lies in greater emphasis upon our relationships at our own level as a basis for our myth making.

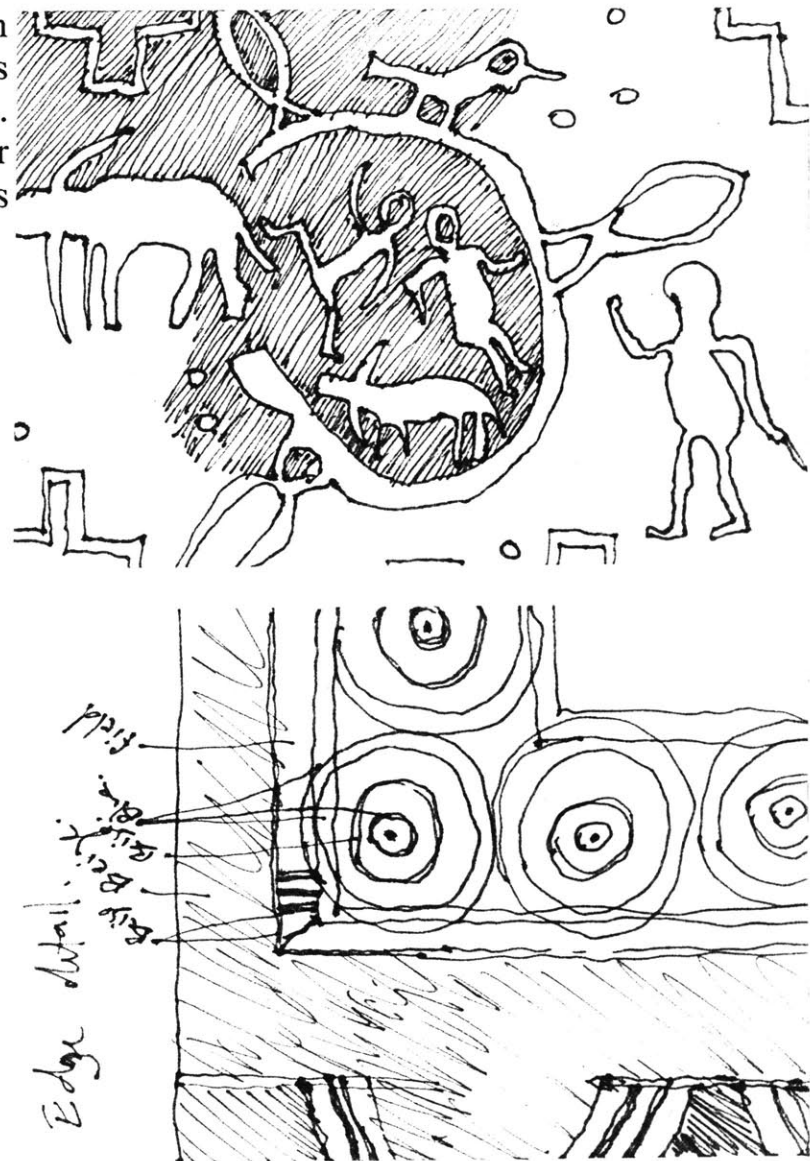

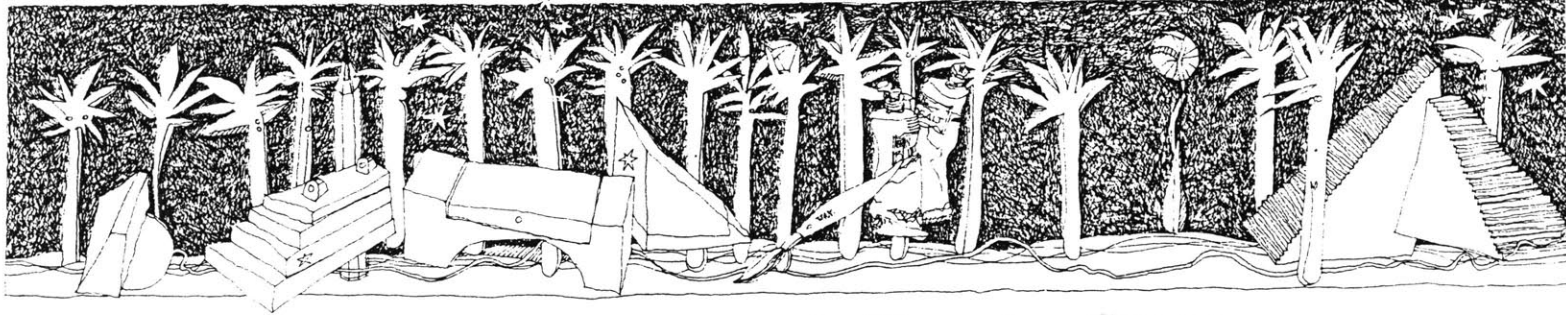

An Observatory Campus

*A religious Site.

*A place for a circus or carnival.

The Basic Ritual:

Take the old ideas, and cast them into a bath, a fountain, the source, from which flows a river of purification, to a dam, welled up, almost overflowing with newer and more wonderful dreams.

Along the river and around the dam are organized, like the pavilions of the Alhambra, or Jaipur, a series of observatories. Places for looking at, touching, seeing, smelling, hearing, tasting the elements, a place for contemplation, a place to gather creative energy a place to feel connected to the world, I really crave that sense of connection, and wonder if such a place could really provide it.

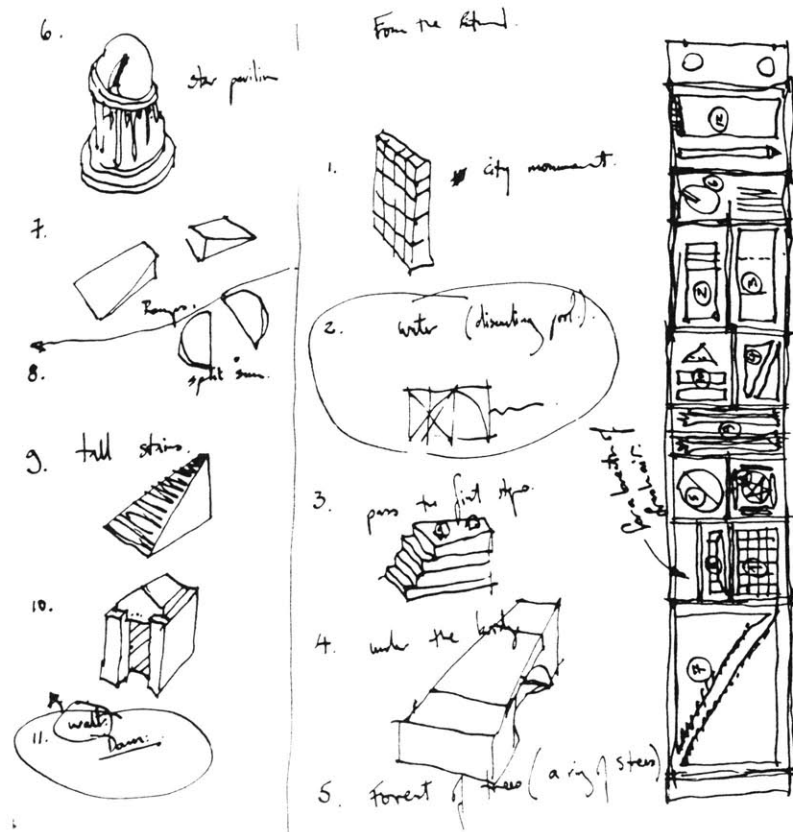
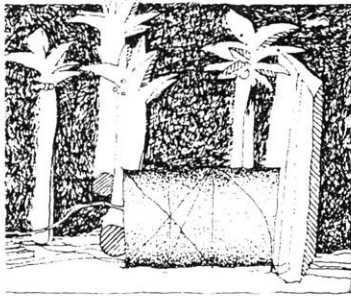

Scale:

1. Palm of the hand scale - from the smallest element of nature, can be generated the greatest of landscapes as we contemplate it, if this is true a toy box, of miniature observatories, wooden blocks, like a game could provide, at least in intent a model of the observatory.
2. First thinking model scale- giving greater meaning to the observatory idea, imbued with the ideas of the intended mega-sculpture, the intensity of connection to the elements as described before, and containing a set of tools, of artists materials, magicians wands. A series of pencil boxes, pen cases, paint sets, paper folders etc, fitting again into an artists bag. Hopefully the tools will be able to carry the love and care of the box maker, into the hands and soul of the artist, and onto the paper, into the works, new and connected works from traditional or new tools, and boxes arranged around, the artist as he or she works, in a sensual observatory, a pile of tools.
3. The scale of Furniture- still as playful as the toys, as connected as the observatories, filled with energy to soak through your bum as you sit on a step or a chair. A desk for a business

Piece of the Puzzle:

Tiny Box.

1. The Box / the Site

- a tall house
- split by a river.
- a box.

- a landscape
- a procession along river.
- an orientation point (the camp)
- a spring
- a shrine.

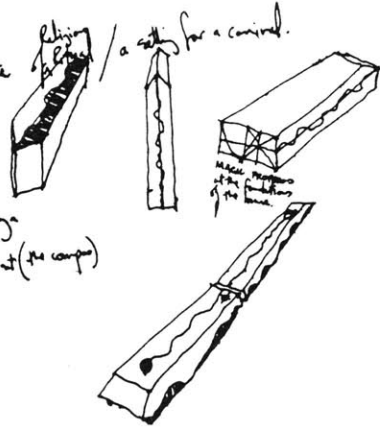

manager or an easel for an artist, files and bureau, all turning the setting of everyday work or leisure rituals into a slightly more rich animated experience, again i wonder what the effect will be of this kind of stuff, whether it will really breed enthusiasm in its daily use, and if it will wear thin after a while, get tired, loose its beauty its desire for excellence and wonder get bored, or whether there is some timeless quality, where excellence if attained doesn't fade.

2 1/2" x 10"

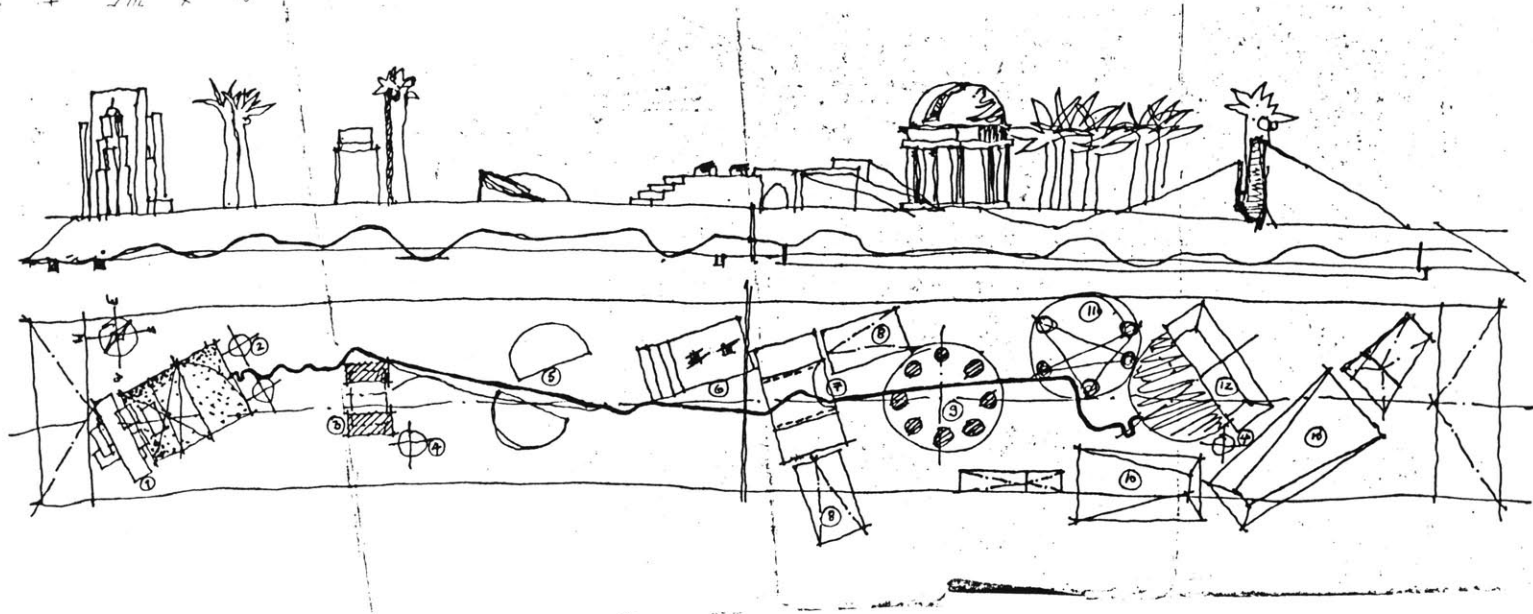

4. Architecture- the observatory, a large sculpture for all of this to happen, the site, mythical, but why not? right now, i don't know, maybe opposed to the grand entrance to M.I.T. opposite the Neoclassical, intellectual facade of 77 Mass. Ave., a site for a carnival, a religious ritual, or just a walk from Residence to school, to sit on a step while eating lunch.

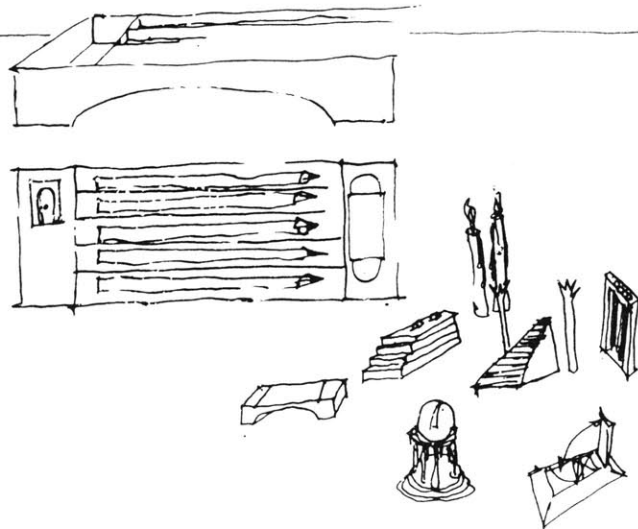
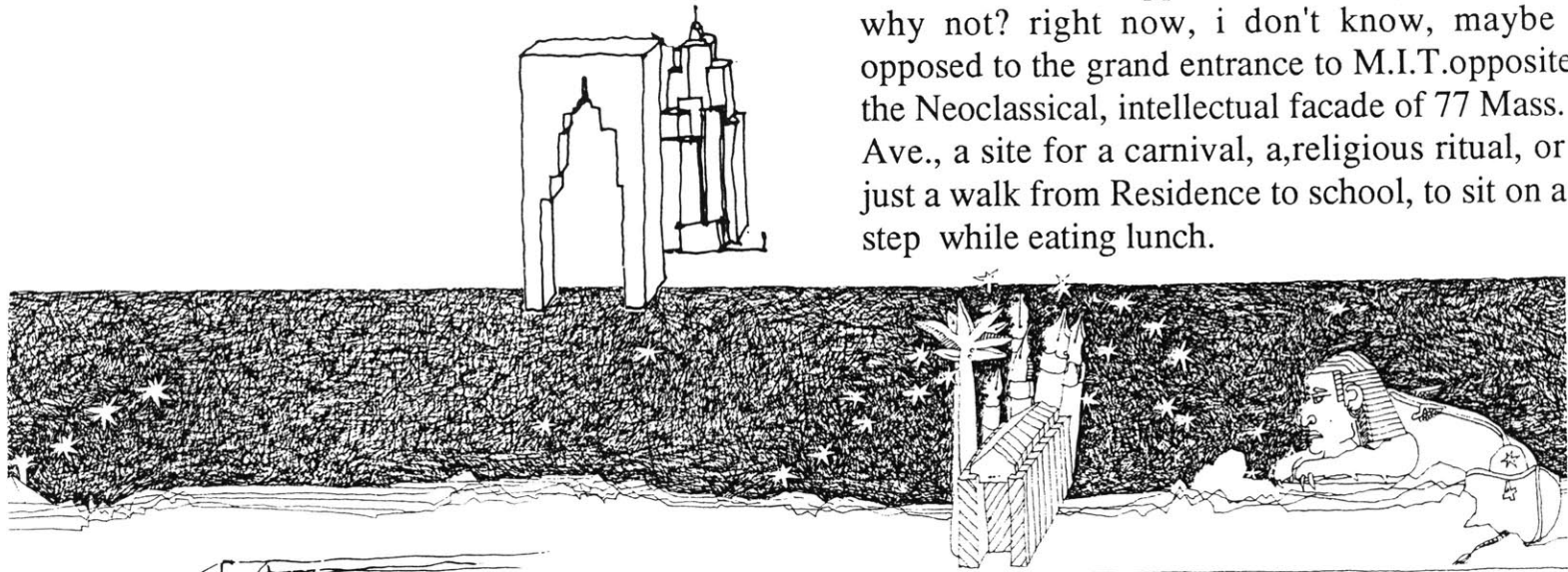

Somehow, the translation from stage to stage seems to direct in terms of shape, and should really be development to inform the next step in a deliberate way.

Toys need more playfulness, in order to really inspire the next step. They need to be more and more and more intensely within the order that they want to be, and then inform in some different way than they do now.



Themes:

- 4 elements:
 - earth
 - water
 - fire
 - air
- 4 characteristics:
 - mass vs. fluidity
 - stairways (around & from)
 - centrality (in & out)
 - fragments (cloning)
- 4 scales:
 - the toys (surrey of mythology)
 - the tools:
 - furniture & pieces
 - architecture & monumentality

Learning ideas

4 qualities

- ritual
- love
- mystery
- halfhearted meaning



form & physicality:

Form & physicality:

SCALE 1. TOYS:

NO.	ITEM.	DESCRIPTION.	LINKS.
B.	<u>THE BOX</u>	<p><u>LINKS:</u> A PREVIOUS MADE WOOD, LOCATION & CLUED JOINTING, SAME THINGS AS THE BOXES IN SCALE 2.</p> <ul style="list-style-type: none"> - <u>Boxes</u> compare in kind to orient. - <u>Boxes</u> like to do specific instances and to see results. - working with the wood is a very sensory experience, almost weird in its tactile nature. The result is a play of its own work, as one works with it, and dialogue with the material is possible. - I like it, it's a little dirty, you sense a little. 	<ol style="list-style-type: none"> 1. WORK 2. WORKMANSHIP 3. MATERIALS 4. CONSTRUCTION SYSTEMS 5. FUNCTIONS <p>Ref: Japh Correll, each boxes</p>
A.	<u>The Things:</u>		<p>like between volume</p> <ol style="list-style-type: none"> 1. think about volume 2. material - clay etc. - do any hole or fit - it's not over, but a part of and over, beyond being part of the set. <p>just a plane to start</p> <p>length, form & shape are used, understanding</p> <p>- surface, slight thing, light parts, with of holes</p> <p>- light & shadow? (with the part of that and it's effects)</p>

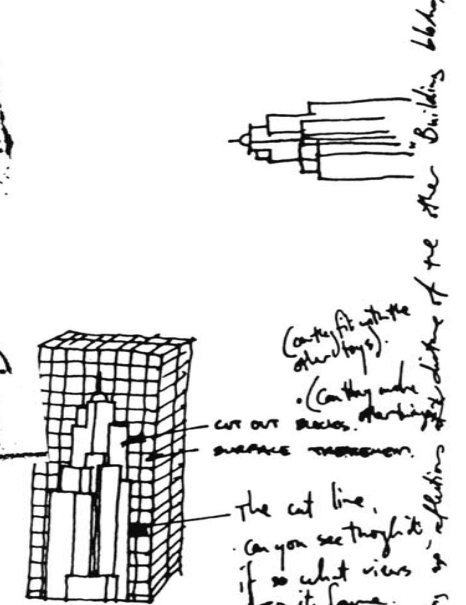
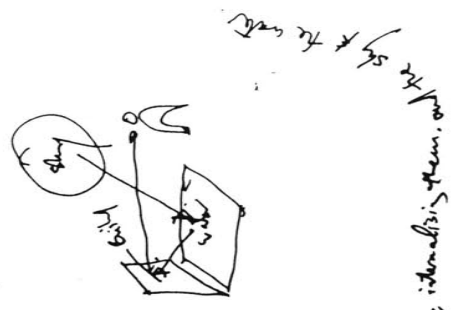
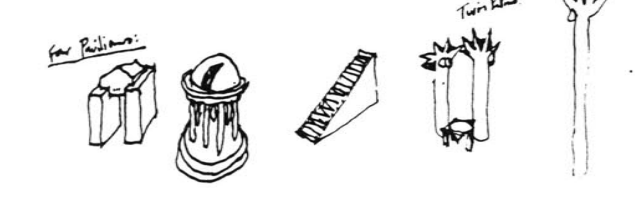
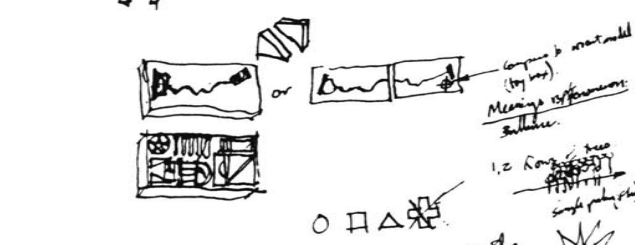
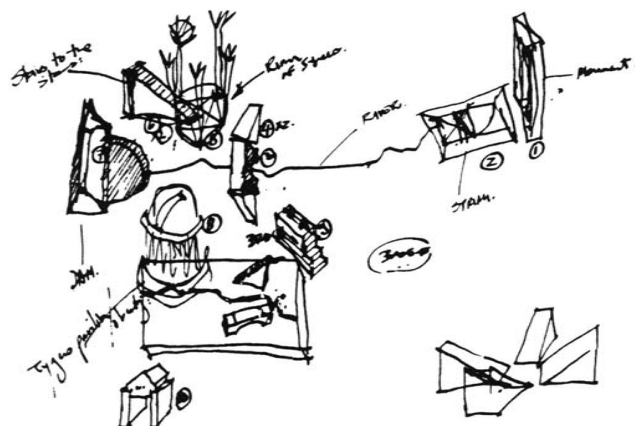
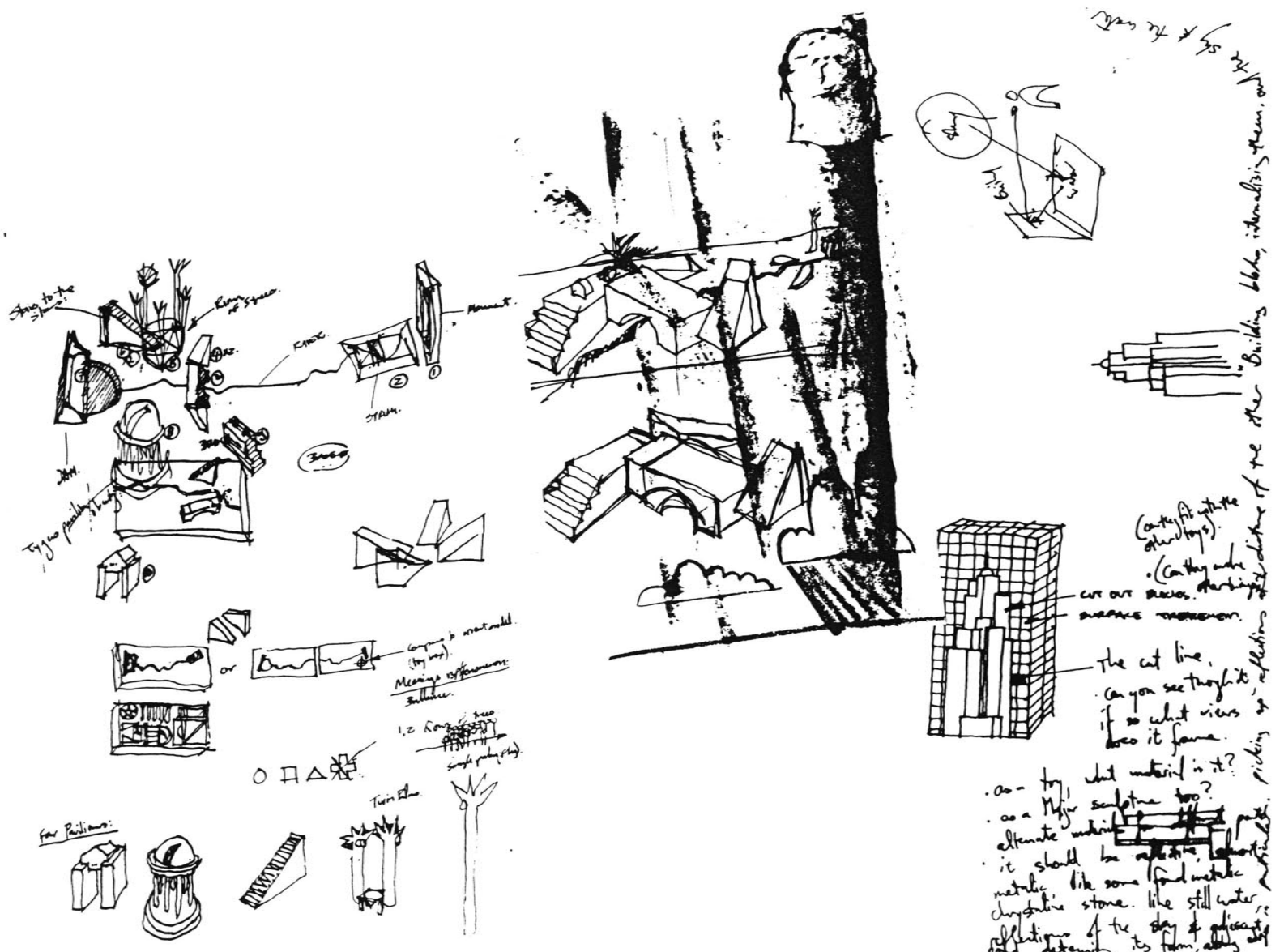

as - try what material is it?
 as a major sculpture too?
 alternate material
 it should be reflective, metallic like some found metallic crystalline stone. like still water
 reflections of the sky & clouds
 form determine its form, ability

Compare to the other Buildings like, internationalism, and

The City monument & its immediate site.

What about light penetrating through the gaps in the pieces, & the views through. (nature of cut surfaces & how they refer in shape & texture & color to where they were hit from - also how they might refer across to other elements.

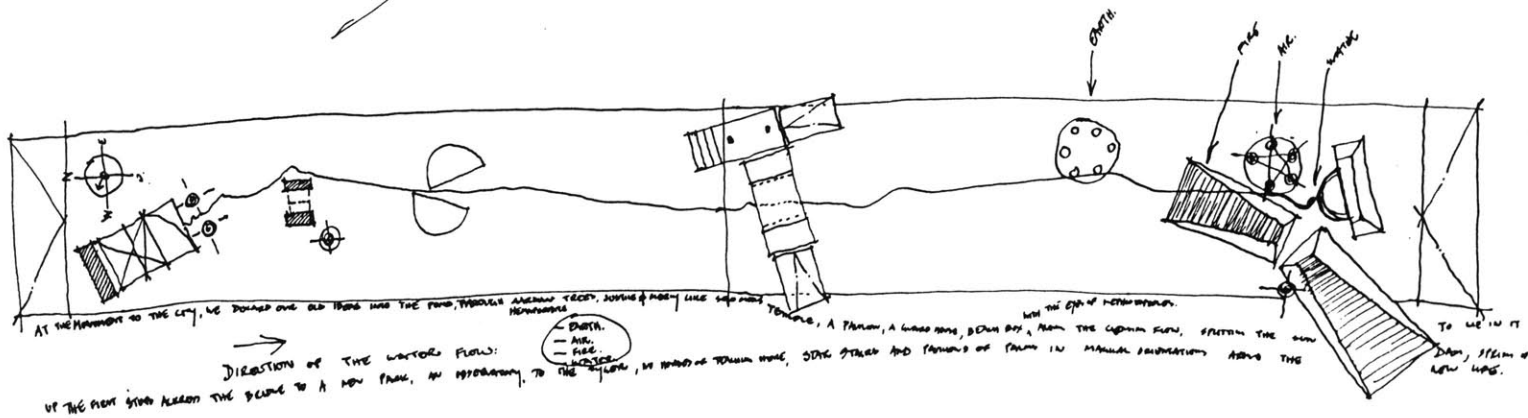
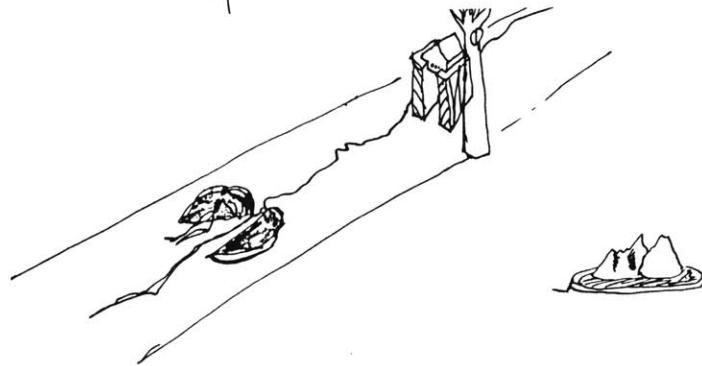

The Nature of the Object

We begin our inquiry into the object by recalling the Japanese term "suiseki", that is, the contemplation of stones. If you were to find a stone in a particular area and bring it back home to your house or garden, the shape of the stone its color and texture and its origin have the power to transport you in your thoughts back to the place whence the stone came. In some way the stone retains the essence of the place it originated, and it takes only contemplation to educe that essence.

Within "Suiseki" are a number of different classifications. Stones can denote a close landscape, a distant landscape, or an object. The stones which denote archetypal landscapes near and far, can take on one of twelve different representations; there are eight object archetypes which a stone can represent. Of these there are objects which remind us of other objects and object representative of abstract patterns, all the classifications refer to the same mythology as do Geomancy and "Feng Shui". So in this case, the object contemplated has definite physical characteristics, through which the contemplator may be transported to another place in physical and spiritual form.

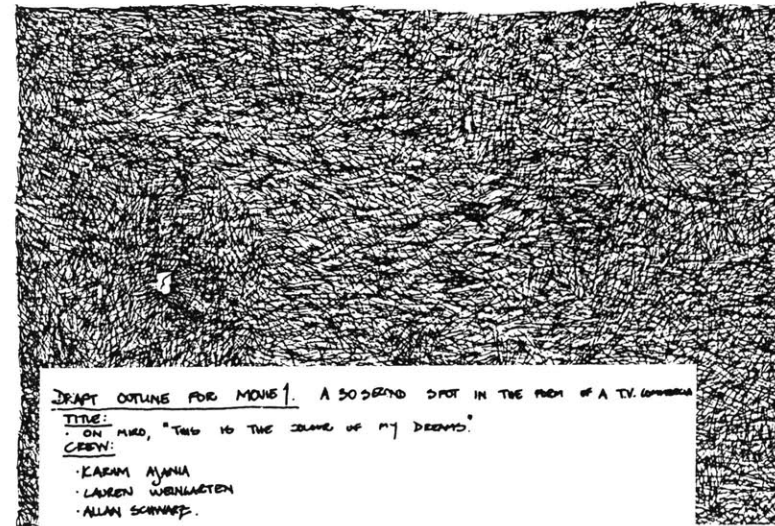

MEDIA:

VIDEO, ALTHOUGH IMAGE IS NOT AS SHARP AS FILM, IT IS MORE FLEXIBLE & PERKS IN EDITING, ESP. SOUND & SYNC.

SUBJECT:

THE ILLUSTRATION OF A POEM 0:50 SECONDS WITH ORIGINAL DRAWINGS & MUSIC AS A STATEMENT OF INTENT TO FURTHER ARTISTIC ENDOWMENT I.E. MOVIE 2, AND LOTS MORE DRAWINGS & PRINTING.

EQUIPMENT:

PROD: - 1X VIDEO CAMERA. (EXTRA BATTERIES)
1X DIRECTIONAL MICROPHONE, LOW CABLE & HEADPHONES.
1X TAPE DECK (CAMCORDER) - SAME MAKE AS FOR CAMERA.
2X 1500W LIGHTS. & LOTS OF PAPER & GELS.
SOFT: - 2X 30 MIN CASSETTES (VHS)
- 2X 30 MIN AUDIO CASSETTES.
- CREW LUNCH.
EDITING SUITE: OFFLINE.

LOCATION:

ALLAN'S STUDIO, THE PIT, C.A.V.S.

SCREEN PLAY: ATTACHED.

PROJECTED PROBLEMS:

- RESOLUTION OF VIDEO NOT IDEAL FOR SUBJECT MATTER.
- EXTREME DIFFICULTY LIGHTING DRAWINGS
- CONTINUOUSLY DIFFICULT SHOOTING DRAWING IN PROGRESS AS IT TAKES A LONG TIME TO DRAW.
- VERY RESTRICTED TIME, ALLOWS FEW DETAILS, CAN ONLY CONCENTRATE THE ESSENTIALS.

This transportation of the imagination has its roots in real, physical, material things. Within the system of suiseki, many landscapes and object types have been observed and codified. When you list the place and pick one of these characteristics in a stone there, you actually take something of the place with you. Almost like taking a photograph, the act of taking a stone back home from a place visited is a moment, a framed portion of that place. This gathering of mementos is not uncommon to western cultures, either: it is a way of imparting a place with special meaning.

This deals with taking found objects to reflect a landscape, now using these techniques, we can manipulate objects, stone or otherwise to externalize and represent our own inscapes.

In the same way, I took images which are important to me and used them as the basis for redesigning the constellations. Here a personal typology, arrived at in terms of objects, has been established to transport one, not to an existing landscape, but to a landscape which one intends to make or imagines. Tools normally used to represent reality are used here to represent fantasy, This is the first step toward making fantasy into reality.

On Miro "This is the color of my dreams"

Depressed, in my small apartment I sat, drawing black with a little intense optimistic cobalt blue, heavily rendered in ink and gouache, recollections of the African skys and the intensity of the numerous stars. Not all good memories, but ones which explain a little of why I left. Wrote a poem, to expurgate the memory. Read it to a friend back home, whose response was to set it to music, male voice and solo viola, published as opus 49 no.2.

We have collaborated regularly on common ideas and projects, so this response was a natural one. Exploring yet another medium, looking at the links between ourselves, the sky, and sounds, and sights. Proposed a short video to record the ideas.

Looking to the right-hand side of the page at the observatory campus, one can make out that the images used in its typology are the same as those in the planisphere. A first attempt at giving these images physical form is made in the design of the observatory campus. This may be seen as a first route toward investing extra- nature in an object.

Another method is to decorate the objects made, or to make objects directly in the form of things you have imagined.

A third way is to directly model physical intentions, as architects and sculptors have so often done. Here, the maker can build a scale model of an object which could be sculpture. If the model is made of the same material and the maker is fantasizing of the full scale, it can inform him of the actual/ intended object in its landscape. This source of knowledge in the object can and should also be tapped to convert fantasy into reality. If, on the other hand, the scale model is made of some nonanalogous material as is so often the case in architectural models, there is a much further jump to be made before the image can be realized.

DECORATIONS:	POEM: (TITLE)	MUSIC: (TITLE)	SCENE:	STORY BAND:
1				1
2				2
3				3
4	YOUR PINK RESEMBER	RECORDED IN STUDIO.		4
5	IN BIRTHA			5
6	SUNNY BY			6
7	ANNING.			7
8	STORIES IN AND 1.			8
9	There is a blue			9
10	There is a blue			10
11	There is a blue			11
12	There is a blue			12
13	There is a blue			13
14	There is a blue			14
15	There is a blue			15
16	There is a blue			16
17	There is a blue			17
18	There is a blue			18
19	There is a blue			19
20	There is a blue			20
21	There is a blue			21
22	There is a blue			22
23	There is a blue			23
24	There is a blue			24
25	There is a blue			25
26	There is a blue			26
27	There is a blue			27
28	There is a blue			28
29	There is a blue			29
30	There is a blue			30

The ritual of Design Through Making.

The whole idea of design, is to find appropriate forms for the usable objects that we make. That sounds fine but is it enough.

The idea of ritual is to set up formal patterns of behavior, a Way of doing something, which covers all the steps, a kind of process check list, which traditionally doesn't ask too many questions. "why is it so? because that is why." However in the generating of a ritual there are many questions, and most of the activities which are codified, are really explanations of the questions one wants to ask, couched in the familiarity of the ritual. You don't have to ask every question every time, but occasionally as one goes through the motions, a thing or two becomes revealed, especially when a ritual is structured around a process which is recouringly reflective, such as design.

Communication of Ideas and Intentions;

Having agreed that the process is essentially reflective, it is necessary to externalise the dreams and put them down, outside of oneself, so as to be able to look at and examine them, a first statement.

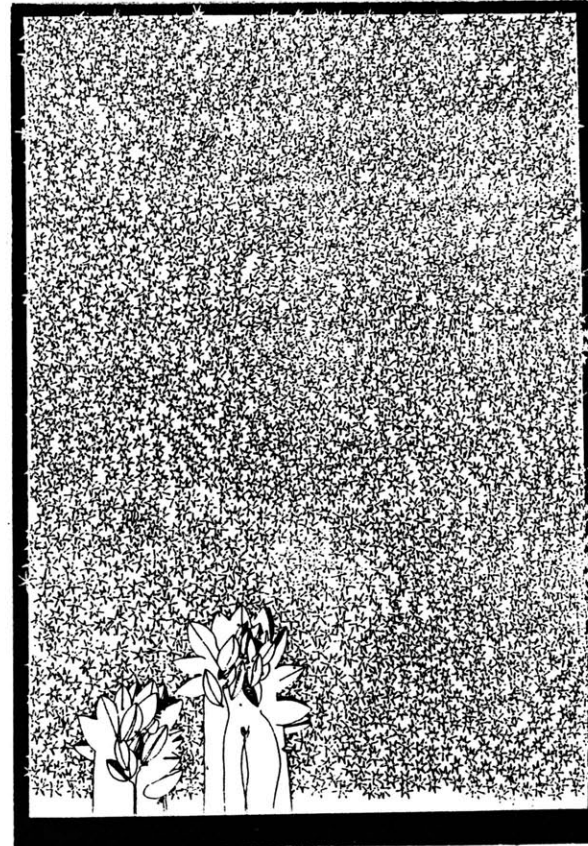

Star Pictures; and the development of a new iconography.

I started drawing the sky, black night sky, or at times of transition, dusk or dawn, in the veldt mainly, where the sky is very dark, and what fascinated me was the darker it got, the more stars

It can be examined in terms of three areas in which it must communicate;

1.It requires for the communication with the self , and ones intended process to carry as much of ones intentions as possible ,and for these to be readable by oneself , very often we work in codes of drawing and representation specific to our own understanding of them ,after all our own marks are ours, and reflect our hand. The greater the knowledge of ones own hand the more effective the communication. However this is not such a dry process, and the gap between our control and intention is a great source of inspiration when we put down in front of us, mistakes or work automatically (automatically in the Surrealist sense).Thus the reading of our marks is as important, if not more so than the ability to make them.

2.It has been demonstrated on the opposite side of the page that all work is a continuum, and that design work is desirably not an individuals only activity, so the making of marks and the reading of them, or objects is something of great importance especially when loaded with the intensity that we desire.So we must be able to communicate intentions with the other

appeared, or was it the more there were the blacker the sky became. My state of mind was also kind of black, and the early astronomers, Greeks or Egyptians, i started to look to the sky for my answers, and a sense of identity, clues to understanding what was happening in my life in a condemned third world country.

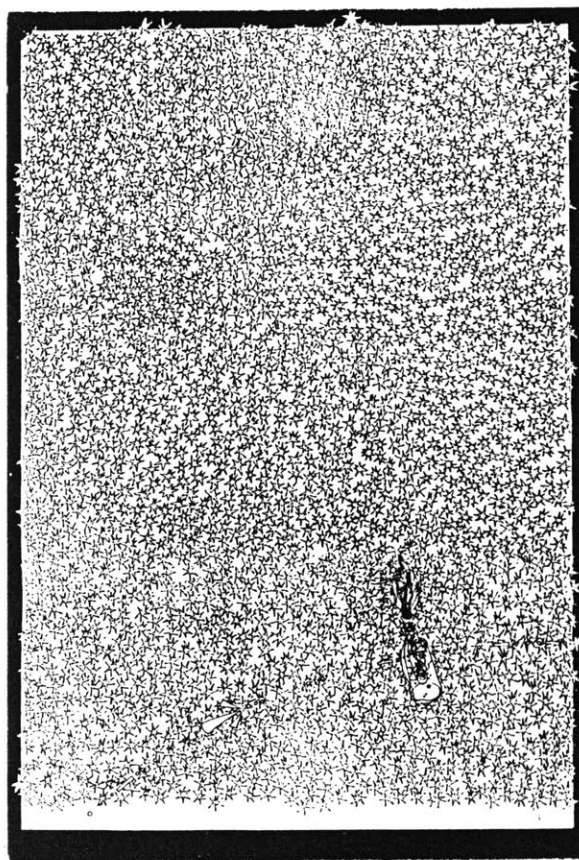

participants in the process, here conventions of presentation have evolved to fairly standard codes, in working drawings, flow charts, specifications mock-ups and models, but they can all be enriched. While they make for efficient definition of size, shape and material, there is no guarantee of their passing on of any other dimension. This does not mean to deny the conventions, just do them better, or add to them. 3. The last area is communication with people one doesn't know, via the completed and isolated object. Kind of a one way street, you put it into the work, and seldom do you know if it was read by the end user. In this thesis I have tested this area a little by monitoring the use of some of the object. And it appears that one must rely on one's knowledge of the general rules of perception for part of the objects effect, the rest relies on the tenuous quality of the vitality of the work itself.

Recording the Steps:

From the notions of communication, whether internally, shared or wholly external, we notice that there is a constant production of graphic or plastic objects as tools and expressions of the reflective

Twelve images started to regularly appear in my drawings and paintings:

1. a pair of palm like trees,(candle sticks)
2. a message in a bottle
3. an assault rifle
4. a suitcase
5. a small house
6. a highrise with a landscape on the roof
7. a picture frame.
8. a T.V.
9. an artificial tyger skin
10. my old army uniform, discarded
11. four red stars ,the southern cross
12. the four colored flag of the water snake

I have tried to group these in fields roughly defined by the traditional elements of Earth, Water, Fire, and Air, and through these define a new astrology, a personal one. After all, the recognized zodiac is an arbitrary applied arrangement of stars only seen from one fixed Middle Eastern view point, having little or no relationship to each other from any other point of view. Through this new astrology, chosen and controlled by me, I have assumed that a new horoscope could be cast, giving me positive control over my destiny. These images could then be used as semi-religious icons when designing "sacred" objects.

process. If we now apply the ideas about objects previously discussed that each object made has its own existence, then these form a separate trail of records of the process. The objectness can be further played up to increase their intensity as vessels of love and care, and to make them even more informative to the design process, both as items at their own scale and as models for a smaller or larger one.

The whole process so far has worked on the basis of one on one reflection and action, at ones own scale,the level of hands on intimacy.By making ones first statements hand held, and having a separate use, but related one to the final project, we explore the nature of the project, at its smallest scale to its visionary one in its essence and with much greater detail and intimacy. And as we work up from scale to scale we change the nature of each of these objects, so that what is a toy as a conceptual site model, becomes a desktop utensil at the sketch scale , the desk itself at a working scale and finally a building. We are left with a whole collection of products which can stand isolated from their specific continuum, and have a real purpose, or can be part of the landscape of their creation, standing as a volume of its history.

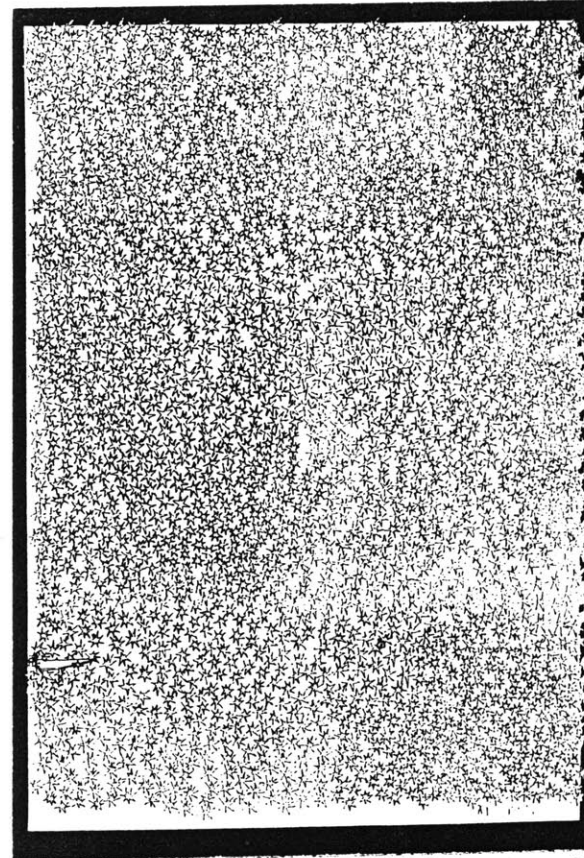

1.Palm trees in a pair(sabbath candle sticks):

*Earth sign linking to to Fire:growth, home of the divas.

*the palm trees, twin fecund phalus, forming a hemaphrodite gateway, like the entrance to Solomons Temple,justice and mercy,yin and yang.

The Design process and form finding for Architecture and furniture or utensils are not necessarily the same. Each scale has its own concerns, own sense of touch, its own possession of space and its own process, but each process informs the other and helps understand ones own scale and position within the others.

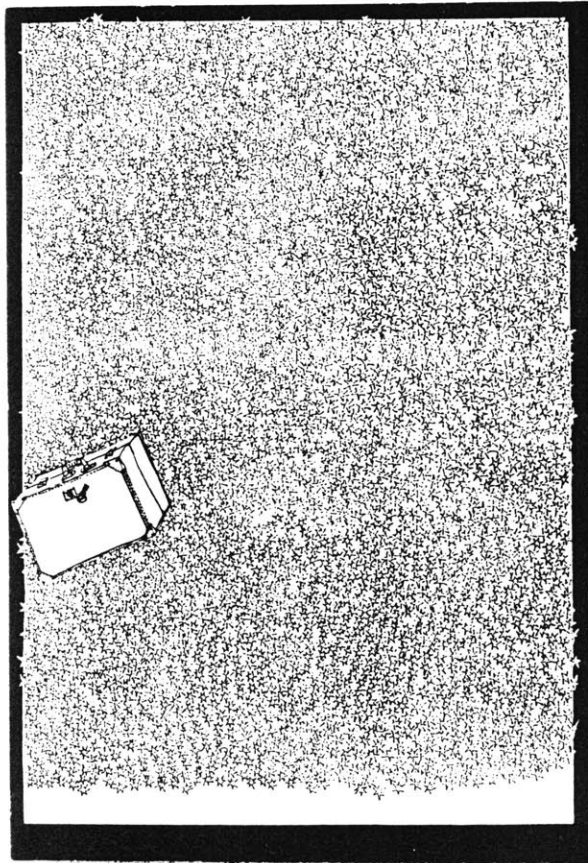

*reminds also of the sabbath candle sticks my father gave me when I left South Africa, and that his mother brought from Germany wrapped in a linen and lace tablecloth.

2. Message in a bottle;

- *the Bottle - Earth, containing water, champaign.
- *the Message - Fire.
- *its Movement - Air.
- *a bottle thrown, filled with petrol, and rolled up newspaper, alight.
- *a call for help, a sign of a last survivor.
- *when thrown through the sky, links to the Poetica Vaginal project of Joe Davis - message to the universe of our joyful yet sad plight.

3. Assault rifle;

- *sign of Fire, anger, bayonet fixed, reminds of the Chinese element of metal, driving from the Earth. Not a good memory at all.

4. Suitcase;

- *Water sign, sign of flux, willingness to move.
- *own little world, earth, internal security
- *a place to put the candle sticks, sign of the wandering Jew, the Renaissance refugee

5. A Small House;

- *Earth sign - like the beach boxes at Muizenberg, or of Aldo Rossi, bound to the

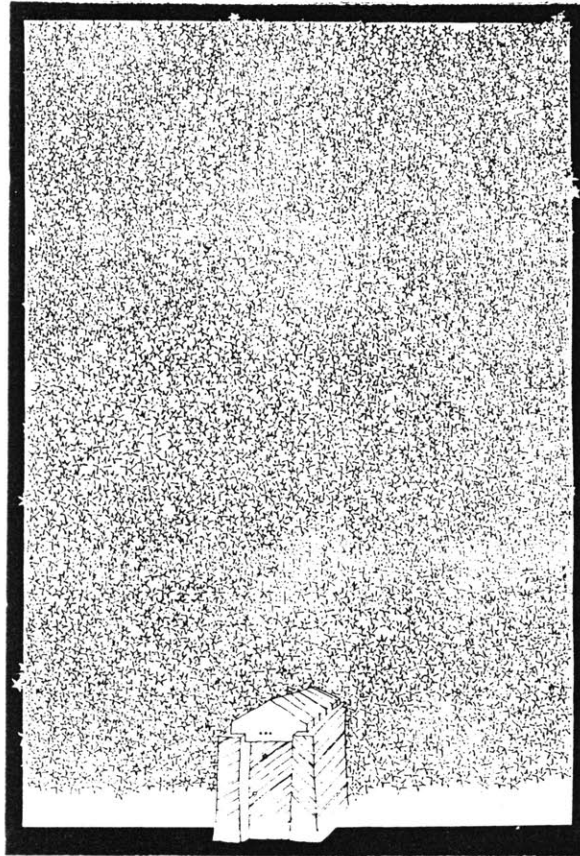

ground

*sentry box, place to watch from,

*built of elemental blocks, like a child's wooden toys.

*undertone of dissatisfaction - Herman Hesse, the Red house in *Wanderings*.

6. A High rise with landscape/roofscape:

*Earth and Air

*reminds me of a project that never materialized,

*an egalitarian grid, equal opportunity to mediocrity, stereotypes for the majority, fantasy for the few, bizarre ecology,

*fun to throw things off, not to jump,

*glass, reflects the sky, bites into it, call in clouds and the sun.

7. Picture Frame:

*Air - sign of the intellect, selection, framing, boxing

*an image of completion and stability, Earth, but empty, needs the picture, images of the ideal

*a safe place to build in and from

*also lots of questions basic to "What is Art?"

8. Television:

*Air

*lots and lots of captivating hot air

*"luftgescheft"

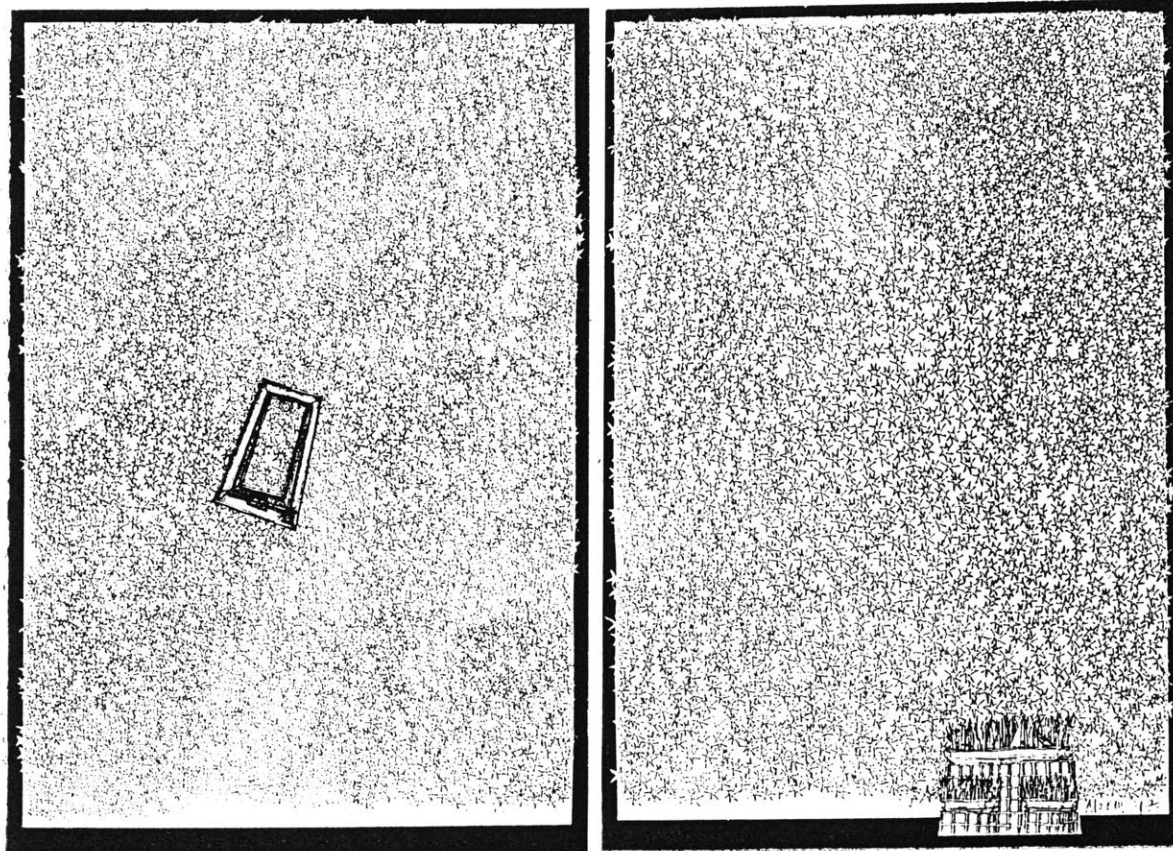

*provides no substance, nice images, celebrities, marketing, communication

9. An Artificial Tyger skin:

*Fire -like Blake's....."burning bright....night"

*symbol of creativity, energy, taking control, respect,

*radically active

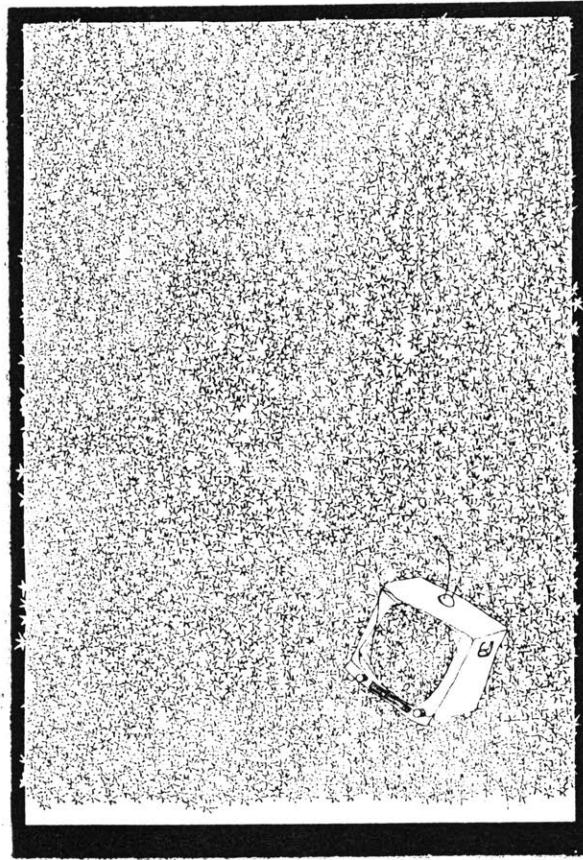

10. My old military uniform, discarded:

- *Air and Fire
- *many symbols attached- bright proud buttons, broad arrows, and insignia,
- *most important, Issia - from ...plough shares and pruning hooks, destruction and discipline turned to productivity

11. Four red stars of the sphinx:

- *Air sign
- *Edward Lear had trouble with sphinxes
- *profile of the mountains of Cape Town, Cape of Good Hope, Cape of Storms.
- *stars of hope and glory, dark stars, the Southern Cross, a good star to navigate by

12. The four colored flag of the water snake:

- *Water -link to the Air
- *the "Vierkleur" flag of my home province, taken and adopted flag of Europe, flag of fierce independence and of conservatism and oppression.
- *the water snake, sacred symbol of change to Native Americans, the animal of betrayal in the Bible, and the divine beast from which we all evolved according to Southern African mythology.

When we mix all these up we get a bit of a picture of the influences that I have felt under the sky, and in my move from Africa to America.

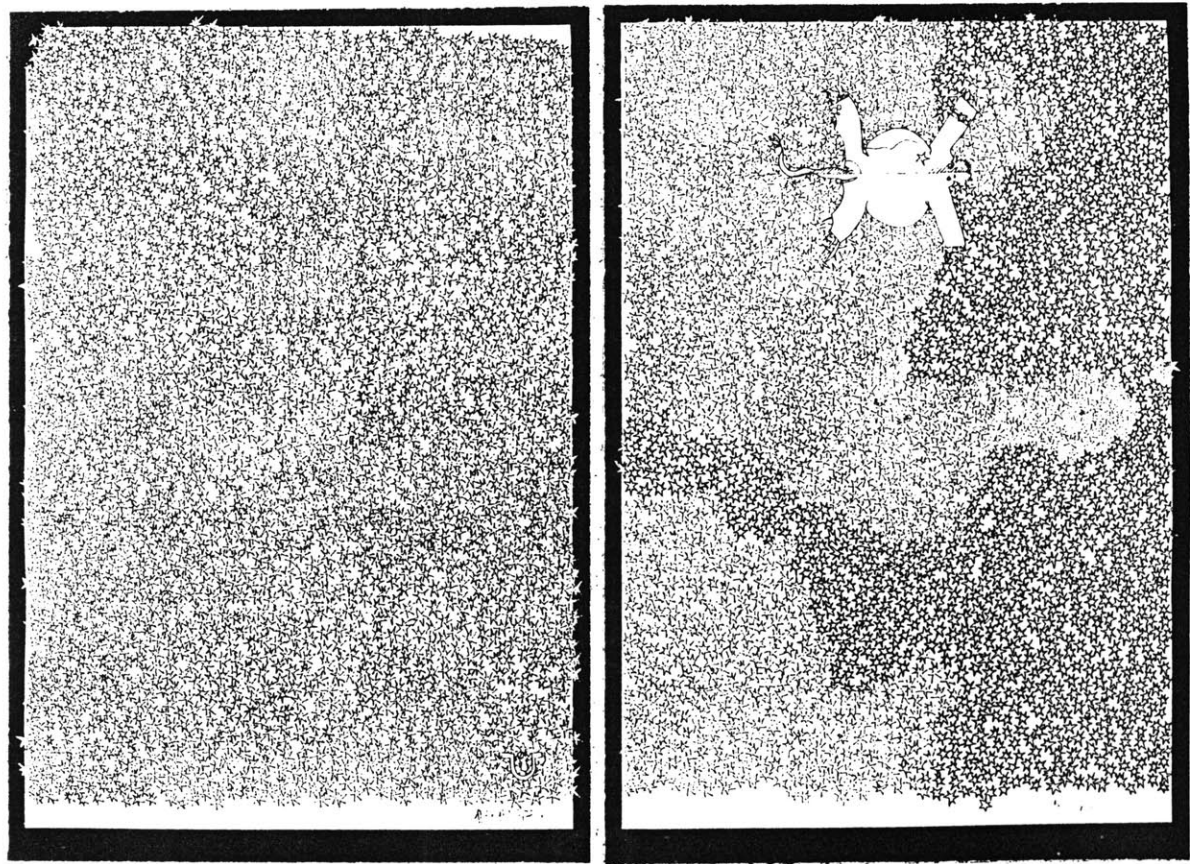

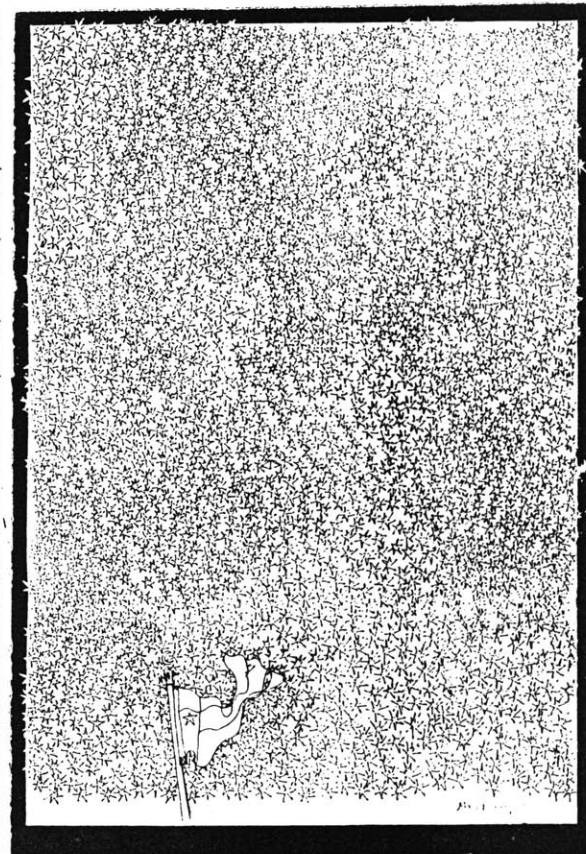
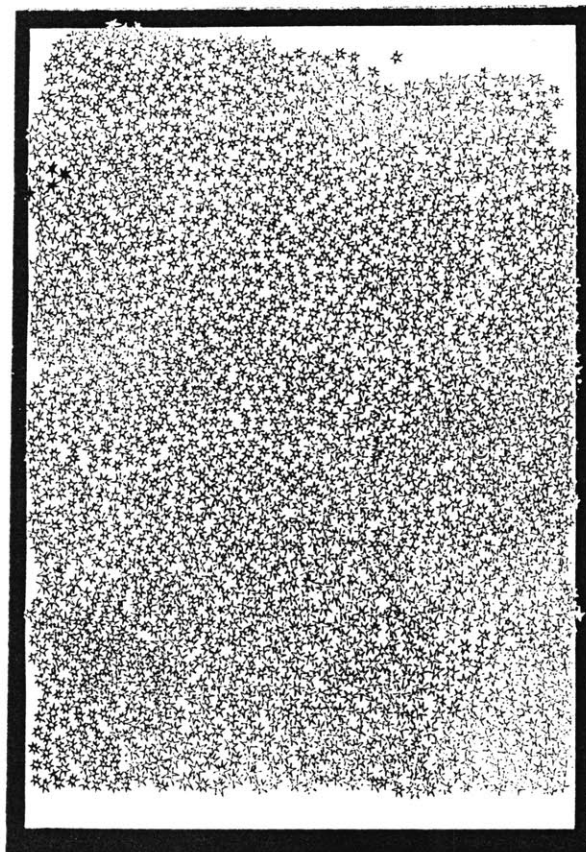

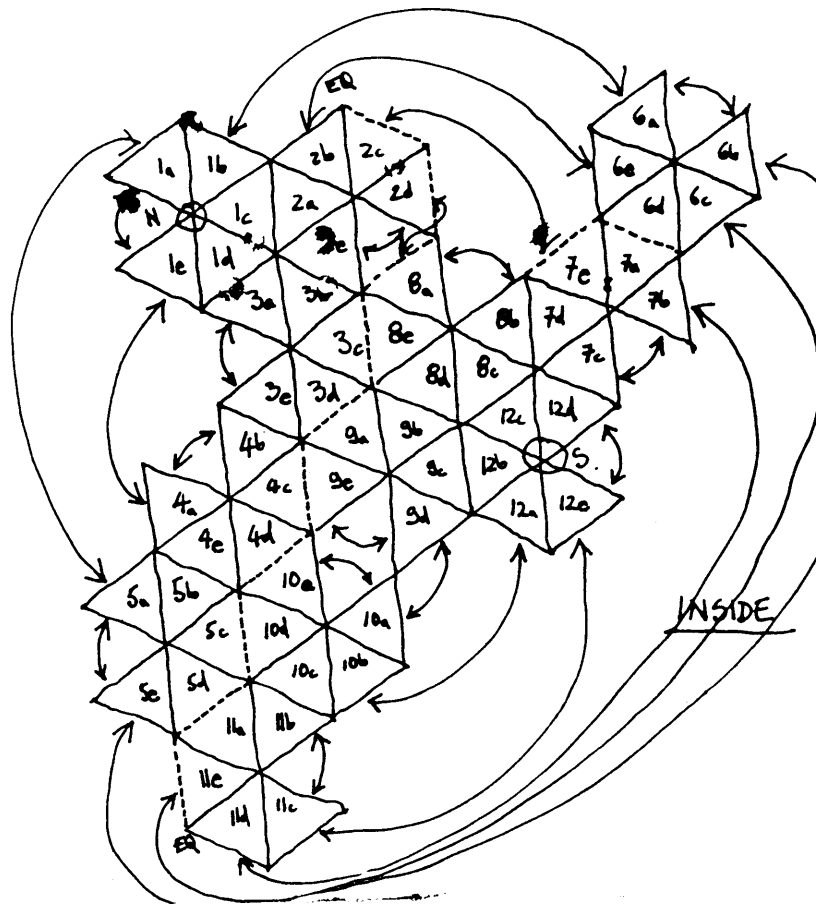

Star Sphere

All these signs were collated on a sphere, derived from the geometric pattern of a duodecahedral star, turned into a kind of a geodesic dome, developed by dividing the five sided parts into equilateral triangles, sixty in all, half outside half facing inside, 120 in all (coincidentally the full cycle of years in the Chinese calendar, meaningless trivia).

Anyway, painted and drawn on the inside surface were the icons, and holes punched to represent the stars, and placing it, centering the viewer at the Southern Cross - the only recognizable standard constellation - with it right over your head, a new artificial sky to read and know the stars from, a new astronomy for a "new alchemist." An introduction to my world, energy and see the real world through slightly altered eyes.

Choosing things to make

A drawing, a cross section through the Earth, from "the split pyramid of perceptions" to the bowels of the Earth, as deep as I can imagine, and up into the Heavens to re-arrange the stars. The objects I will make will all have a place drawn out of this section, but not just a pile of rocks or earthen stars, but usable objects on the surface where we live, practical sensible things.

When objects are seen as leftovers, records of some sort of ritual of life, imbued with all the values and identities of that rich and warm life, objects which link us to what we hold dear;

- *our cosmology,
- *our loves,
- *our God,
- *our basic survival, comfort, sense of being.

The collection of things which I will therefore attend to will form some kind of survival kit, for a single person, me or maybe a close friend or two, and they will be put into use. Some things will be made just as tools and explorations just to find out and express where I stand. Then there will also be some things which are done impulsively, because it

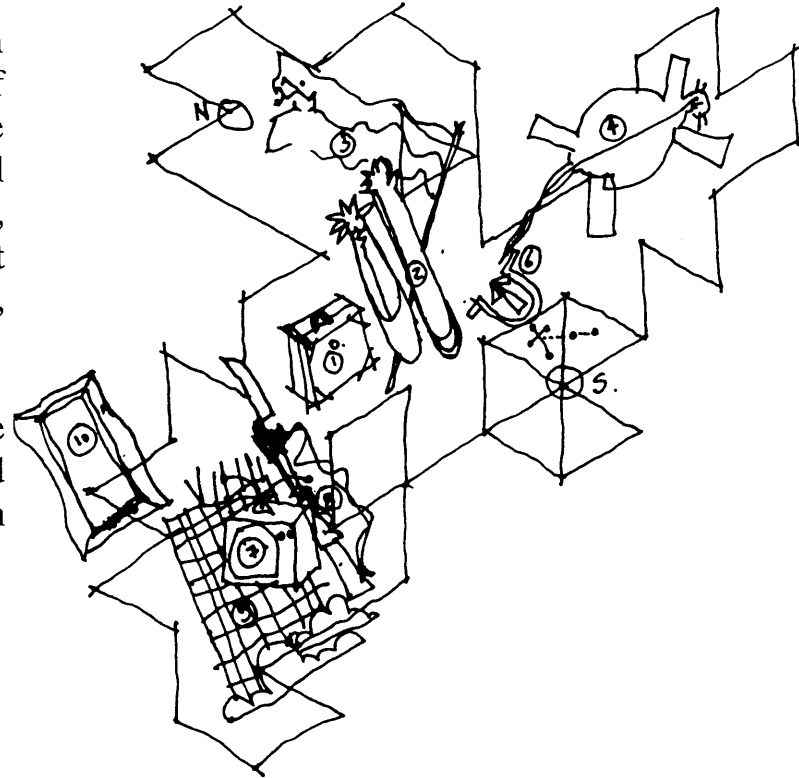

seemed right at the time, compulsively.(put on the kettle.)

Let me make a list;

- *Home; kitchen, bathroom, bedroom
- *Studio; Work, tables and chairs,files
- *Relax; a couch or something
- *Intensify; music, video
- *Garden;
- *Links in and out
- *Empty space;

And the categories into which the objects might fall are as follows;

*Tools; things to help me orient my thinking or record it, like the charts of some adventurer, his maps compasses and pens.Like the stone compass the planisphere of the stars, and observatories.

*Sketches drawings calculations and models; items made for the purposes of exploration,and expression of ideas.They then might break down again into searches for links into the cosmos, to materials, to relations with functional things, to friends; often in the form of "toys or games". For example, the observatory park.

*Usable objects, upscale well attended to

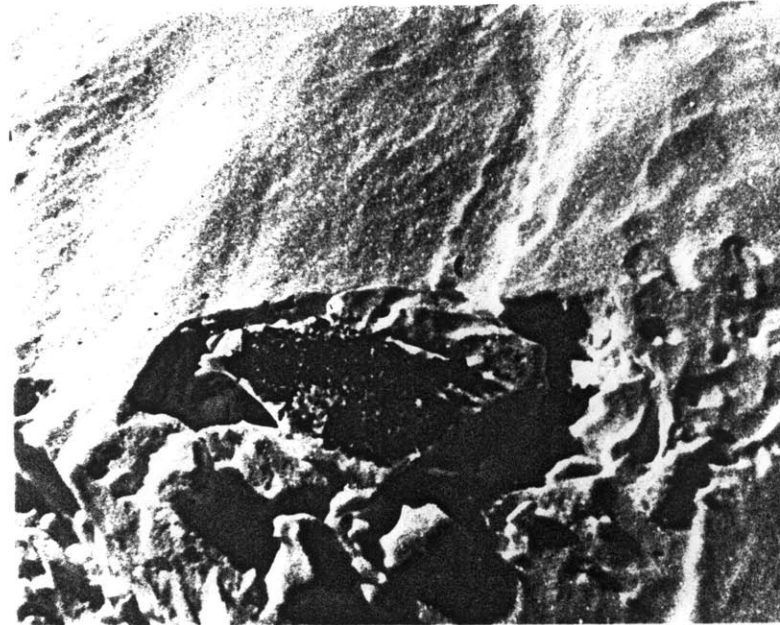

Snow Sculpture

Talk to a friend;

8th Jan.Friday

Same old stuff, I know it, a lot of things well contained, defined and worked out, but the element of "breathing life into it" is still missing. The box is a little like a coffin, of perfect secure and final containment, not the kind of thing which could be a pleasure to carry around. What about the "Feng Shui" ideas of containment and flow of 'chi, the life force.

things, things which would be useful in a kitchen, a design studio, an office, little things, like the pencil boxes and pen cases, an earring container, decorative "tzatskes."

*Good solid stuff; furniture which works and is a part of one's everyday life.

*Maybe some buildings and architectural spaces.

No single piece will fit squarely into one category, but may function at different levels in some or even all of them at the same time, these categories are only there to help understand the range of more places where an idea can move.



Suggestion:

Go to a real site, in the snow, on a coast, water, wind, earth, and sky are all there, and build something of my own scale. An item on the surface, using my body as the only tool (I cheated and took along a shovel) and what I find on the site as the only materials. Look at this for clues as to where to move to next, where and what to work on, what to identify with.

All the previous stuff feels so precious, and certainly I see little growth in it. A weekend's work, let's see.

Friday night I lit candles and it snowed heavily.

Alone and early I went to the site, one that we had discovered in the fall, Squantum Rock. I took along the following ideas to examine;

- *Taking possession of the site (personalization)
- *Making a shelter or a place to feel at "home"
- *A place of some sanctity, a "temple" (from Cassirer's *Templum of space*)
- *To find a balance between the flow of energy and containing it
- *Tapping some kind of life force of the place



*To contemplate and create links with the elements.

Saturday; the first day of work.

*disappointment, there was only snow, and more snow, all of the wonderful rocks, driftwood and plants were well covered, and impossible to recognize at first.

*walked around for some time and with some difficulty in the deep virgin snow.

*I found a place which seemed a little warmer, it sloped south, across a small bay, there was an owl sitting there too, the Romans I believe considered owls a good sign, so why shouldn't I?

*there was a lot of wind here, and the snow was not very deep, there were little hollows on the leeward side of the trees and shrubs, quite sheltered, and a little grass was visible. The bay was frozen, and cracking with the tide.

*I sat and rested, drove back to the doughnut shop and had a coffee, and loaded on the carbohydrates.

*went back.

*there was now a path, my own deep footprints to mark where the chosen site was, coincidentally it fell halfway up a south slope, on a slight rise, the Tortoise of geomancy, prote

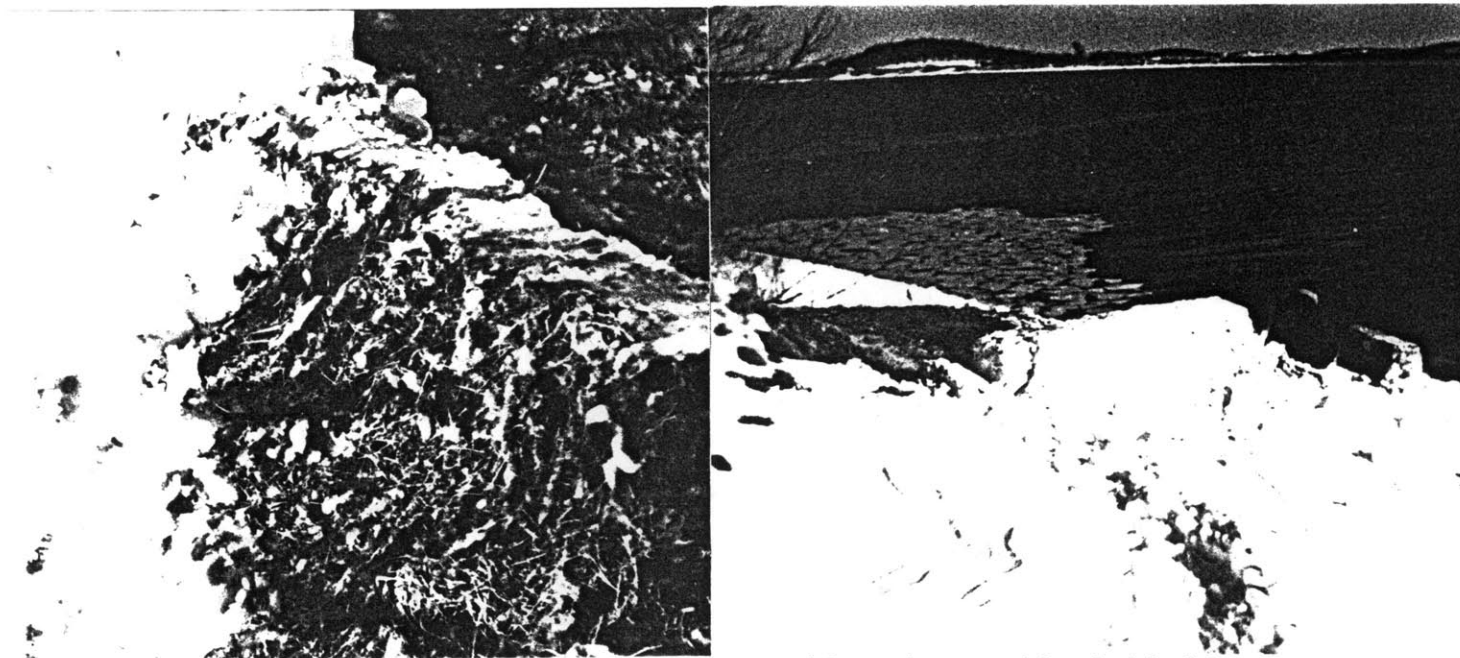

cted by a dragon ridge behind it.

*I started to clear a bit of snow away, and pile it up in a sort of cairn/wall, to stop the wind and make a first primitive shelter, this defined a line running from the top to the bottom of the clear area, dividing deep snow from shallow, now as I cleaned it, the works became more defined, a sharp line, two or more feet deep, the wall, another couple of feet of snow with a little dirt and grass mixed into it, packed by hand.

*I had made my mark, of dirt in the snow just by turning over one piece, and tried to expand



on this idea of exposing what was underneath, edges to the work, defined by what makes my body, my hands or the shovel made against the snow, or snowy vegetation. I took great care to do as little damage to the frozen soil below.

*this spot was only sheltered when I was lying low, and the wind was strong, so I continued my cut down the slope to a small level spot, with a tiny gully besides it. It appeared like some kind of water course, a natural flow (a little innocent to consider water and energy flow to have the same form, but it really felt energetic to be on that path).

*the snow was cleared and this time packed with much more soil and grass to make two sheltering walls, one to stop the main winds, the other a little wind, but also to reflect more sun onto a nice little natural seat, where one could look across the little bay and sun one's face. That I had to rough calculate and guess using my watch and the last rays of the sun, and my basic knowledge of orientation.

*I went home, cold wet and very tired, wondering what the next days work would bring



Sunday;

*returned the next morning to find my solar reflector worked, the owl was basking in my seat, and even more interesting, the wind had weathered only one side of the walls, which now looked like some kind of peat construction. While the other sides were left undamaged. The reflector surface had also begun to erode making how the deflected wind just caught a corner of it, and the sun was slowly melting the surface.

*I built a small wall of stones, now exposed by my previous days work, to dam up the energy flow, leveled off behind this little wall to make a platform to light a little fire and had a rest, now once again in the late afternoon. Took a few photographs and left.

*with new snow it was all covered, then melted and disappeared, almost, except the areas under the wall are now growing greener than their surroundings and there are a few signs of the stone platform having been there. It is still a warm place to sit.

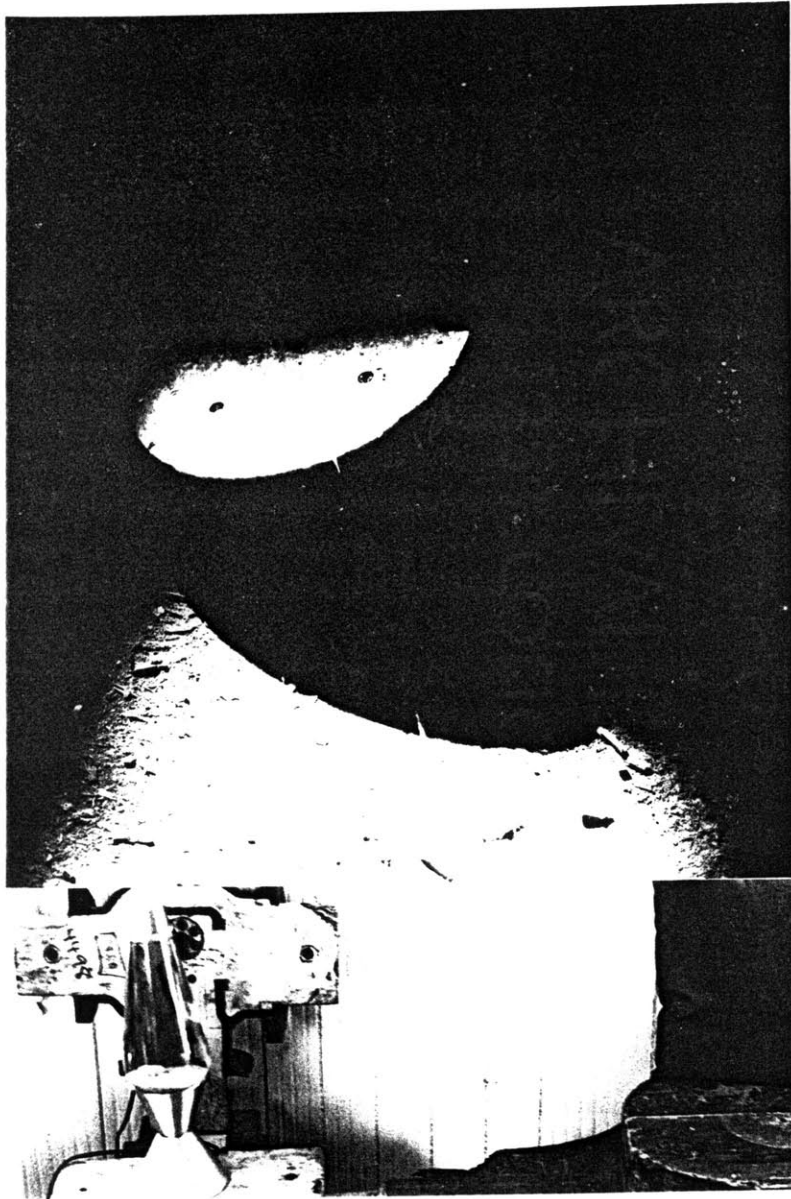

Dies

In January Lauren found a Warehouse, or is it an old factory, I don't really know, in the old Navy yard, it appeared to be a place where war ships were built, on a wharf, with piles and piles of discarded dies and moulds for casting parts of Dreadnaughts or something. As pieces in themselves, covered in dirt, they were a very exciting find. Rough outsides, made to be handled and hold together their almost secret gems of workmanship inside, in brightly colored coded patterns. We wished to use them for something useful and beautiful.

There are two sets of things here to think about; One using found materials in new ways, particularly the old "shields and pikes to plough shares and pruning hooks" stuff and then the appreciation of the objects in themselves, reading them and re-using them. What struck me first was the care with which the active parts of the moulds were made. The accuracy and obvious attempt at approaching perfection, finely worked mahogany and brass, with grain fillers and body putty to finish in slick black paint, where each operation of production could be read, as against the almost rough and ready assemblage on the outside moulds,

sort of left over consequence of the way the insides were shaped, and then held together with basic functional galvanized tags or primitively painted numbers and color codes for identifying the parts, and order of assemblage, held together sturdily but basically with screws, nails, wire almost chewing gum.

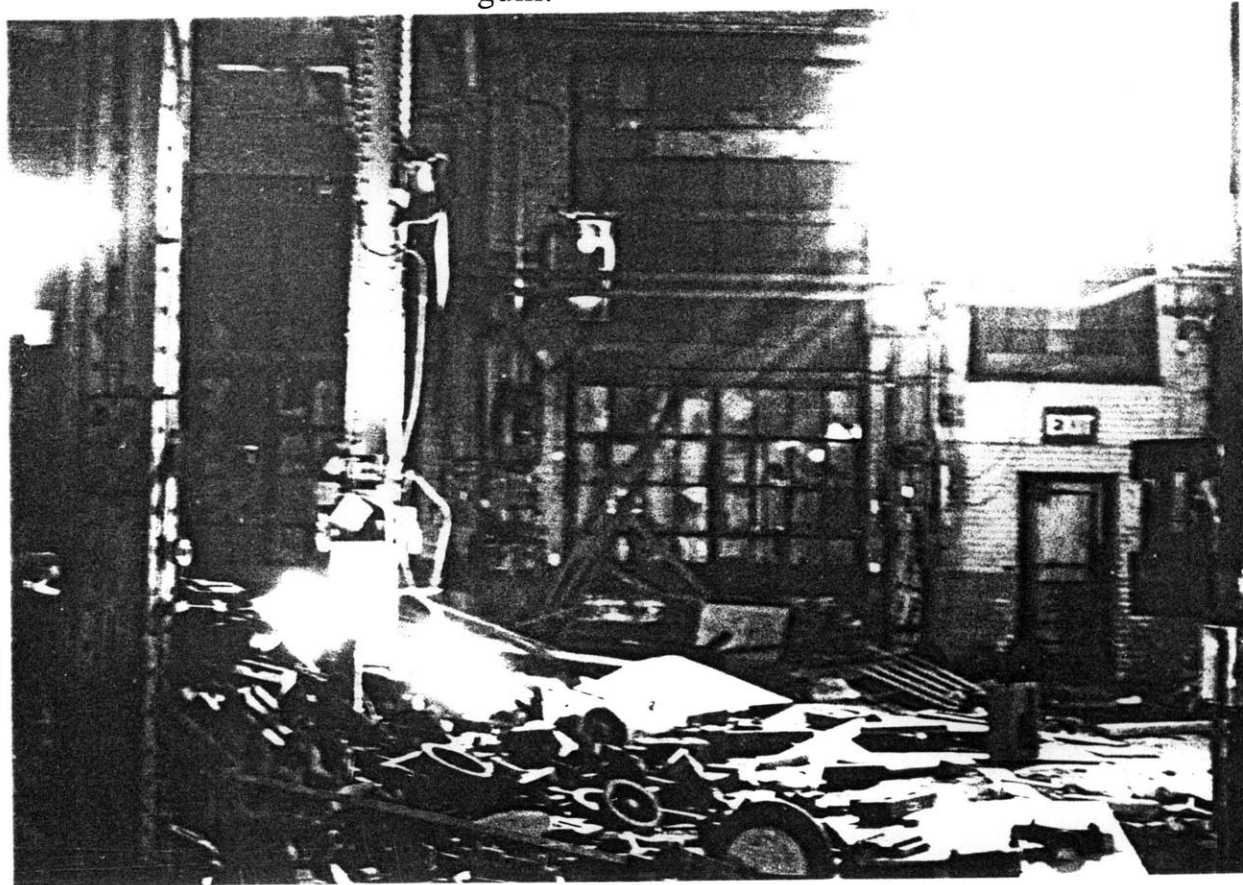

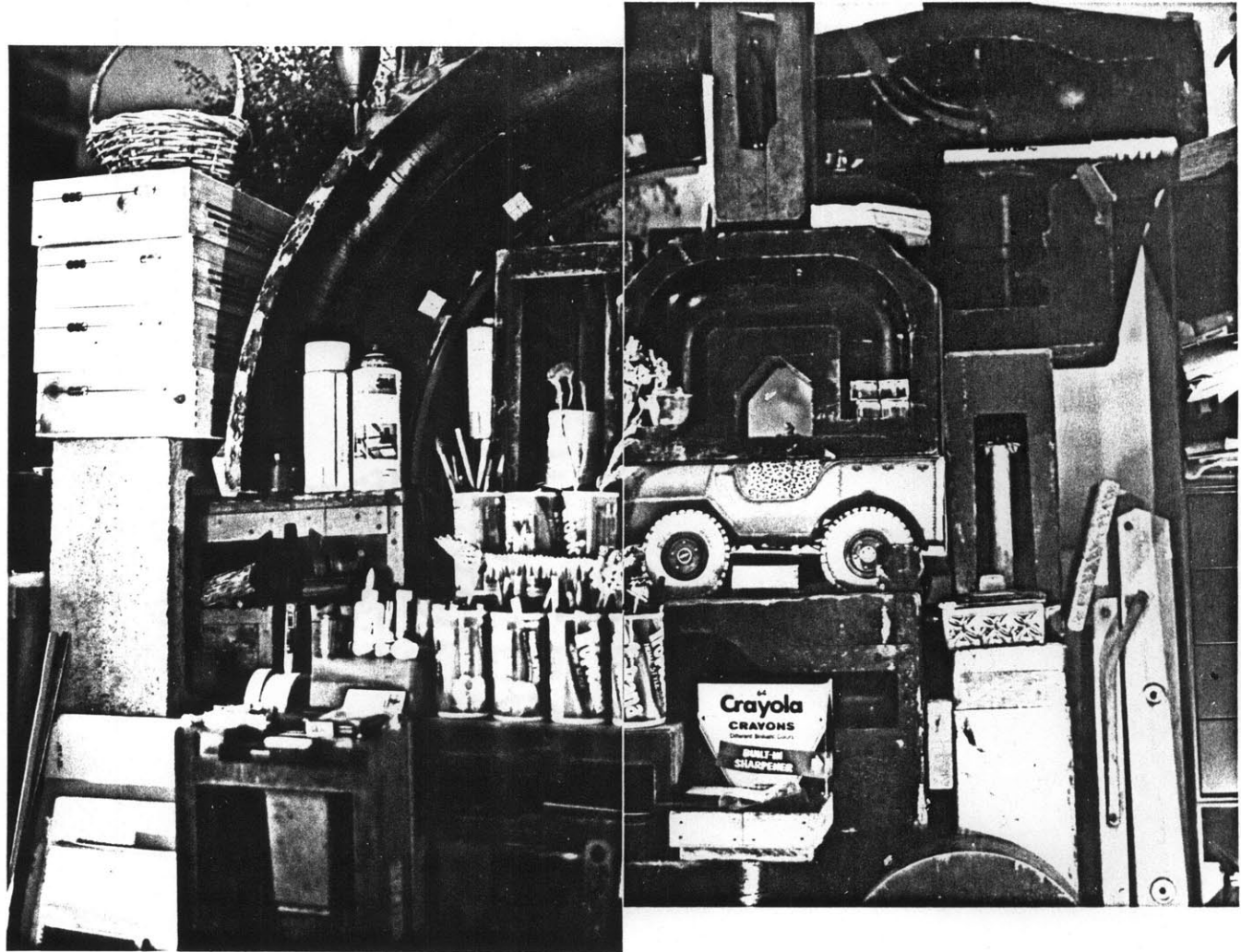

A pile of these were cleaned, and re-piled in new orders again and again to form much needed furniture in my apartment, an object of use, one of

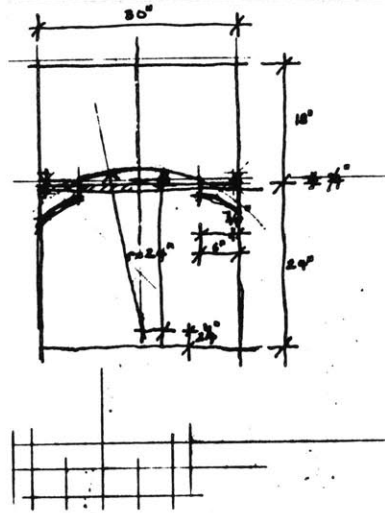
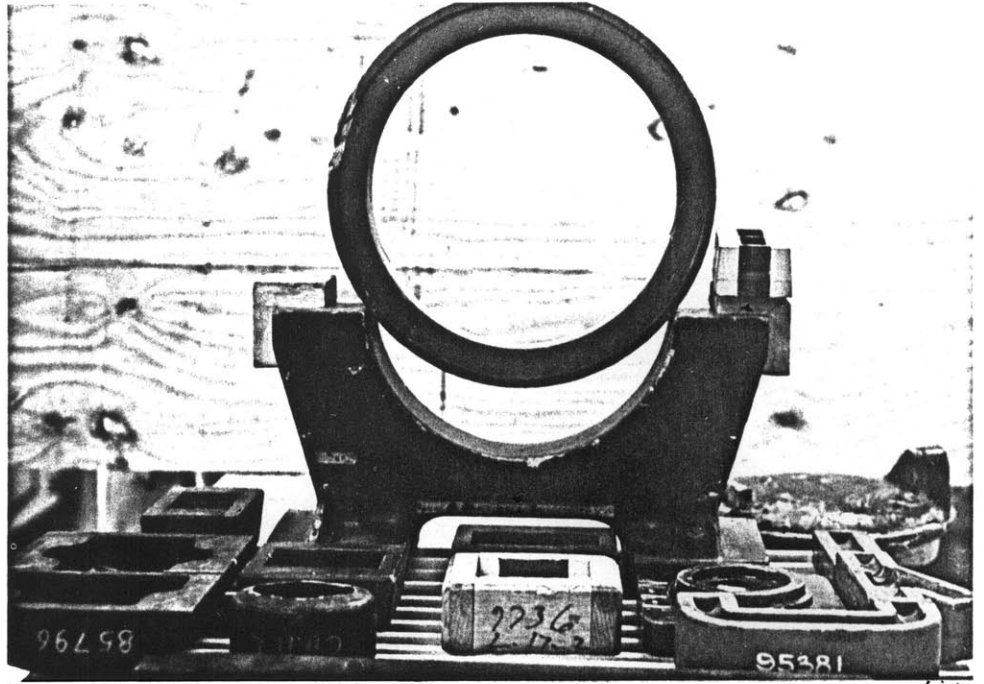
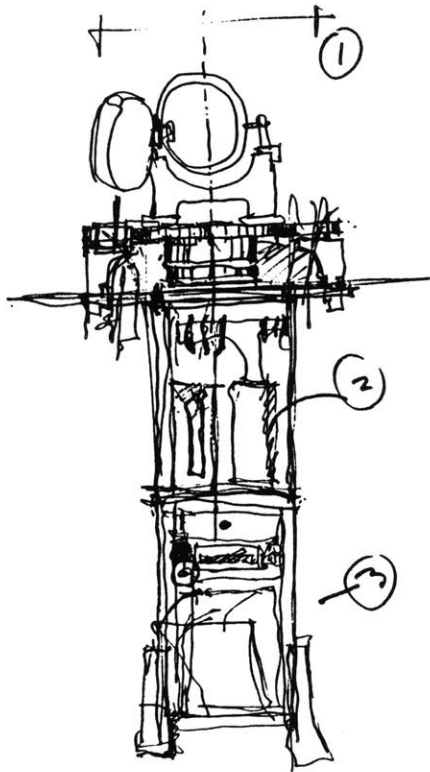
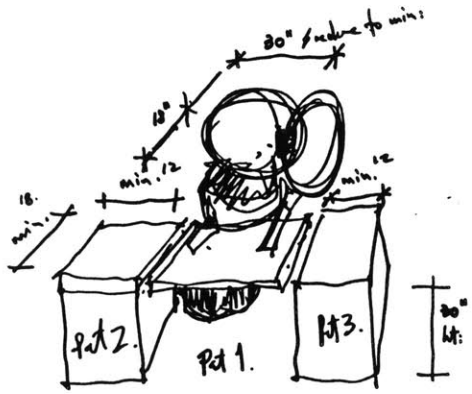

need plywood for top
+ pipe (metal)

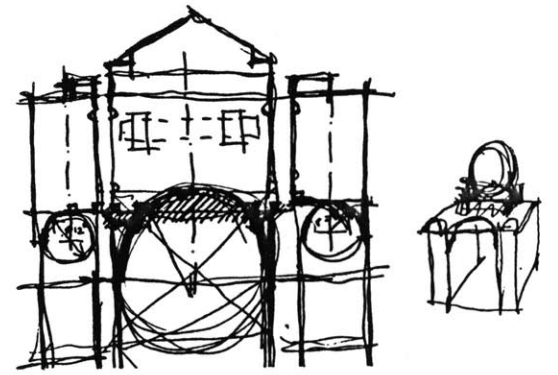

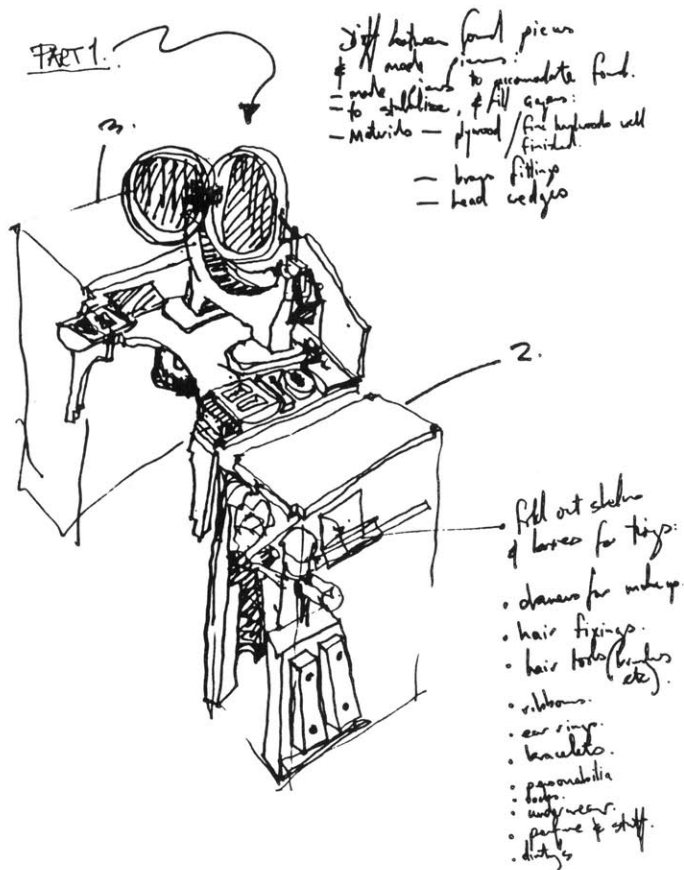

contemplation, and when used and populated with other things becomes a whole domestic /work sculpture.

And then a more deliberate use in the making of a dresser with additional specially machined parts.

The handling of these, the feel of them in my hands, re-working and assembling them into new forms for new uses, or just to play with had a profound influence of how I approached the boxes I then began to make, three in all, and the discoveries in this work, although difficult to write about are very evident in the hands and reflections of the next phase of work.

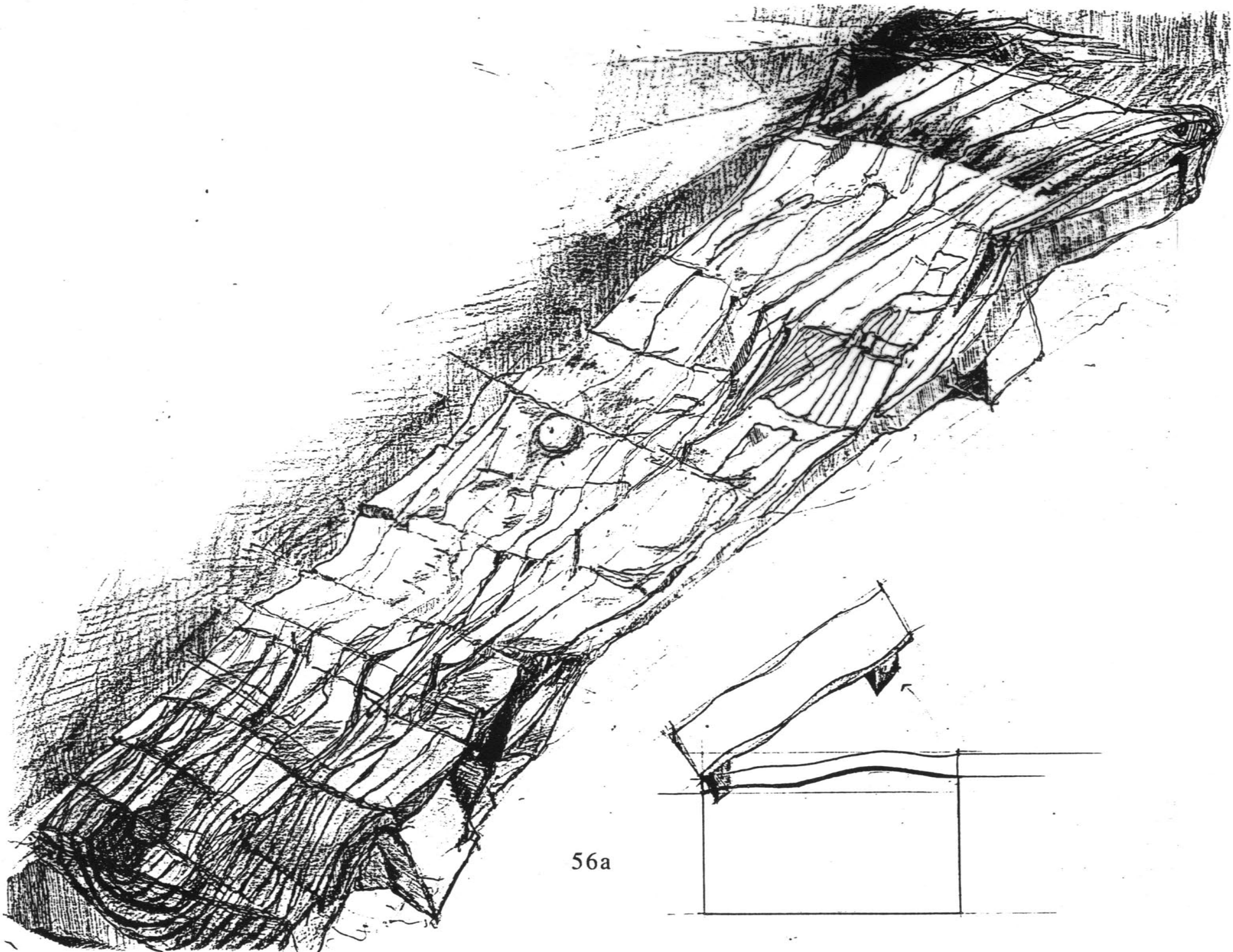

56a



THIS IS A NEW STRONG INSPIRATION & REVISION OF SOME PROVISIONS, CAN WE LOOK ON THAT TO SEE WE CAN USE

AS IF WE WERE IN THE MOUNTAINS, THIS BRINGS OUT THE ISSUE OF HOW REAL DREAMING CAN BE & CAN THEY

1. I want to find out what the magic could be? I don't know how to show it.
2. I don't want to find out what the magic could be? I don't know how to show it.
3. I don't want to find out what the magic could be? I don't know how to show it.
4. I don't want to find out what the magic could be? I don't know how to show it.



Transformation of the same plan
Can we use it to show
or transition
Next it is a first step
In the plan just a little of the building might be different
If we express or discuss in the plan

Suiseki Boxes

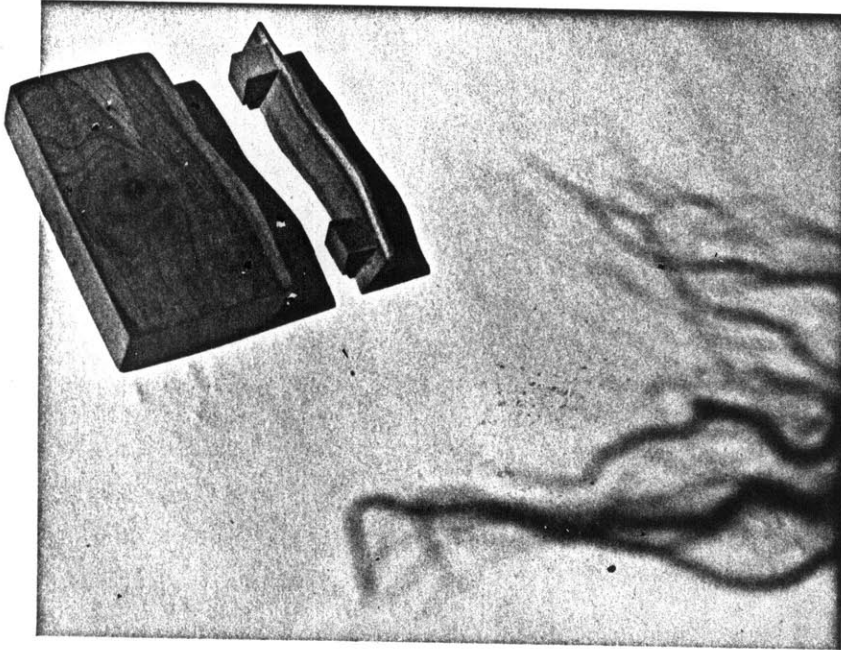

Remembering the dreams and rolling hills of my youth, I picked up a discarded piece of wood, poplar, with a defective knot in it, and unplanned. The changes in color from sap to heartwood, the grain figures, and faults all remind me of that landscape. I cut it on the bandsaw, in a line to reinforce the grain of the structure, and then decided to hollow out the larger section into a box with a chisel and a mallet. Sanded the box down to a rough hand finish, enough texture to feel the real nature of the wood, smooth enough to read the grain features. Got carried away with the sanding and turned the top into a landscape, put feet on it to hold the lid closed, and to work like the stand of a suiseki when open.

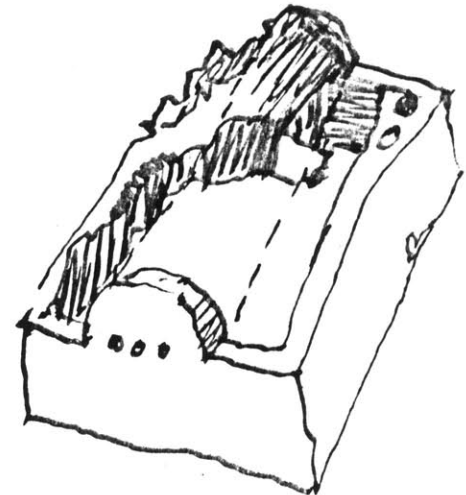



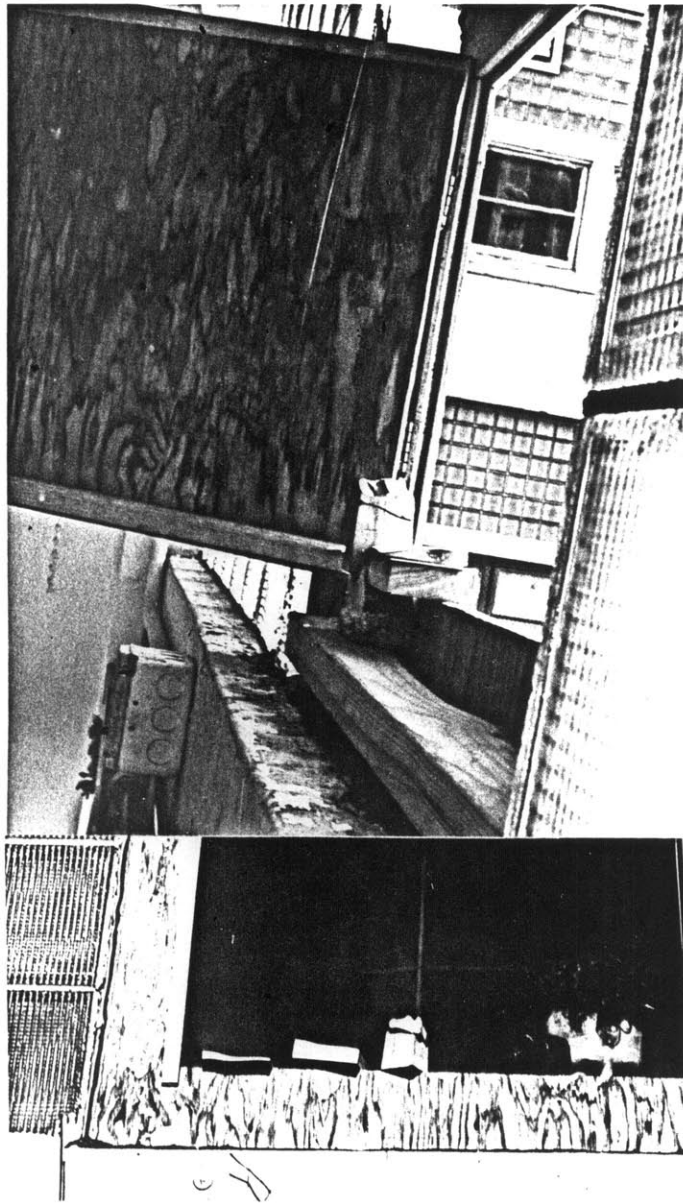

Did a lot of comparing, this box with the pencil box and with the intended ideas of the bedside box. Most Important was how i could capture ideas of landscape in an object, and still make it usable. To prove this I gave the box away to sit on the work desk of a friend who after some time in use, prepared illustrations of it to give back to me what she read through it. Also having only been waxed once when first made, its surface now after some few months are developing a patina, from continuous fingering and handling, in patterns read by the hands of the user and reinforcing the natural images and identities with the landscape.

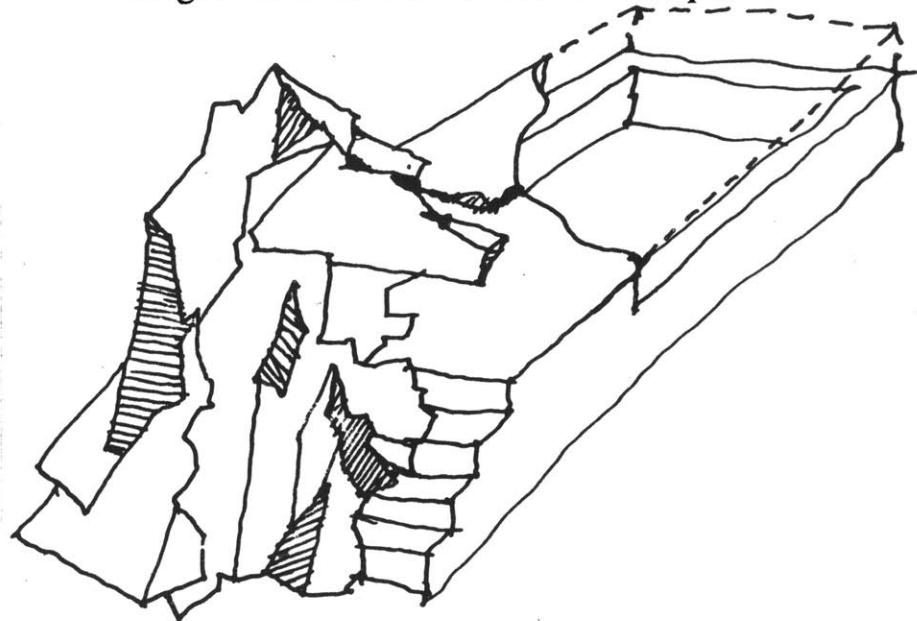

This and the following two boxes were done in a suite learning and transferring reflections from one to the next. The boxes seem to have an even greater sense of being somewhere between the frame and house constellations.

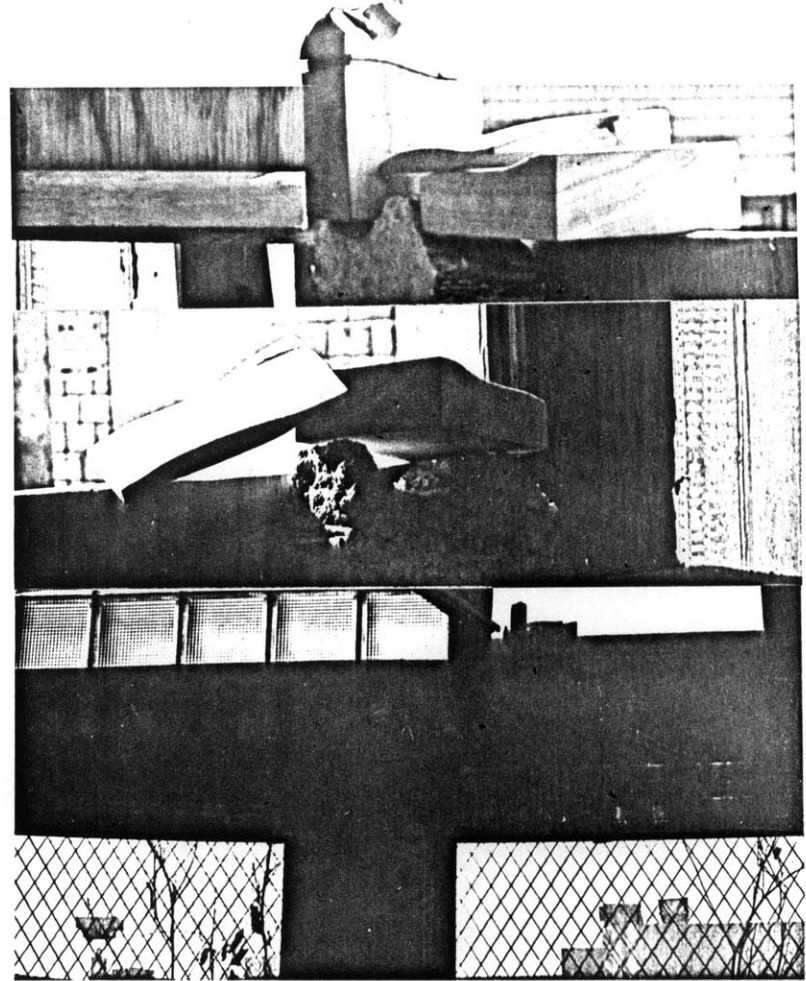
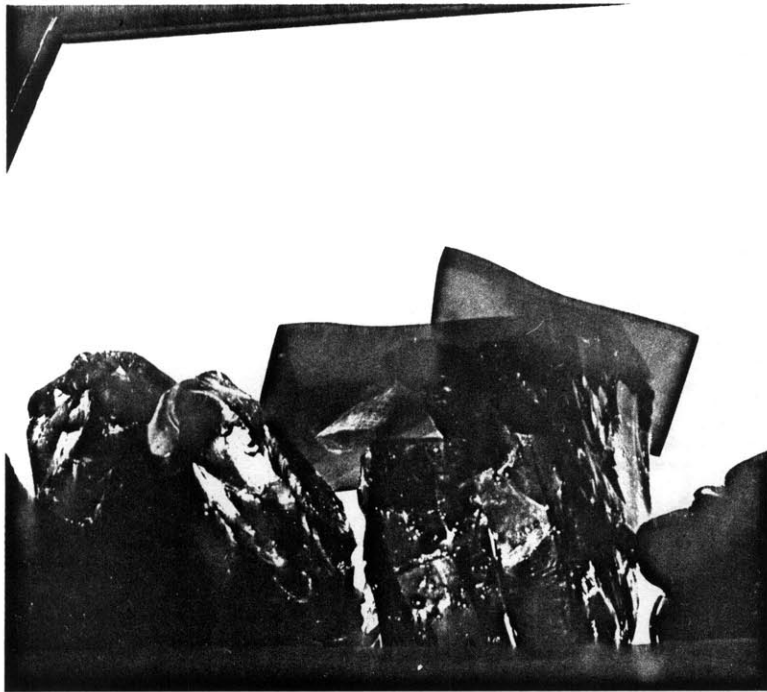



Work Table

I had planned a grand studio where I could sit like Loewe and create visions, with chairs and tables, work stations customized and all that, but having only a small moderately lit room in the architecture school with no furniture provided, a work table became an urgent requirement, I also had no money. So it would have to be made of discarded materials, other peoples waste. I really didn't know what I was doing except that I had collected a bit of plywood, and a few nails, some two by fours were lying around unattended, very close at hand, for the ergonomic data, I once read Neuferts and A.J.Metric, and decided that all you really need is an appropriate body and a measuring tape and to get to work. Table, so high, and none of that nonsense of redefining what to call things either, you stand and work at it its a table, and that was understood. so height to work, less the thickness of a piece of plywood, the length of a leg, cut a few, work out how to put them together so that they would be collapsible, and fit into an ordinary compact car, nail and glue, then make a top, a bit of plywood, and some more bits, a fixing to the leg system, joints between the slats, hey if I recess them(discovered by loosing a pencil in a

gap) I could have pencil trays,same with the shelves
and there it was. No drawings no notes, just
make,and it still works.



Crit Stool

Work in a design studio, whether at a school or in a practice is often a very lonely business, and when somebody comes by to chat, or sit and work with you at a drawing board there is never an extra chair to be found which is the right height, or isn't covered in phone books and old coffee cups, to use at hand, so sitting together at work, or rather not sitting together at work becomes a problem.

I was quite taken by the proportions of the Egyptian furniture remakes at the Boston Fine Art Museum, and I had recently acquired a whole pile of semi-usable pine plywood from a dumpster.

Showing how the chair was made and of what material was important in the design. Also there needed to be a lot of safety factors, as the strength of the material was pretty suspect. I wanted to experiment with the use of a lot of repeated elements to test if one became bored with the mass production or if it would inspire a challenge or maybe just meditative.

So height, depth and slope of seat and position of the back support were examined critically in full scale

drawings, the width of the chair was extended to just over double the normal drafting chair to allow for two intimate persons to sit on it at the same time, or for one person to spread out in grand comfort, with space spare to put a book the phone and a cup of tea. The thickness of the seat was made to be able to deflect with a load of about 100 lbs to add to the comfort of moving or squirming about in the chair, while it is expected to fail at about 400 lbs, but then two people that fat won't fit.

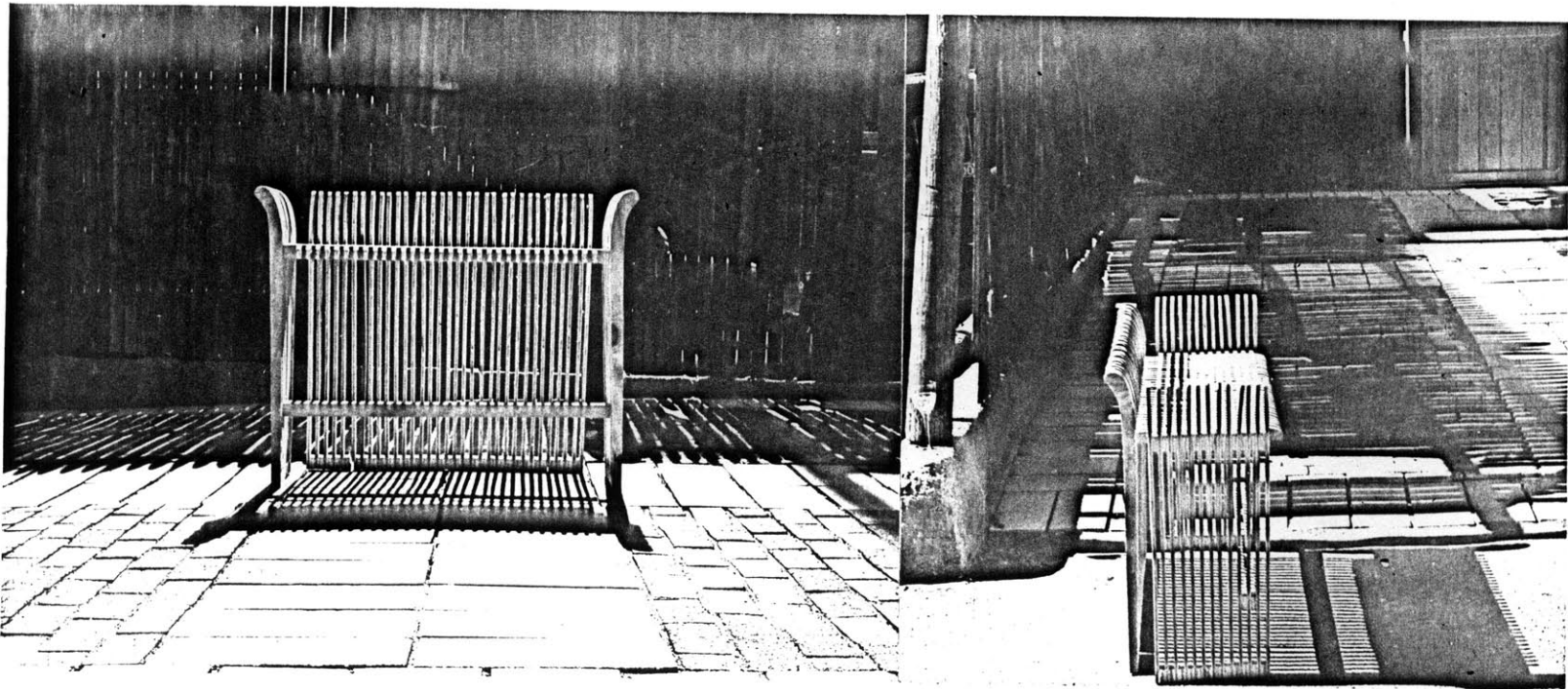

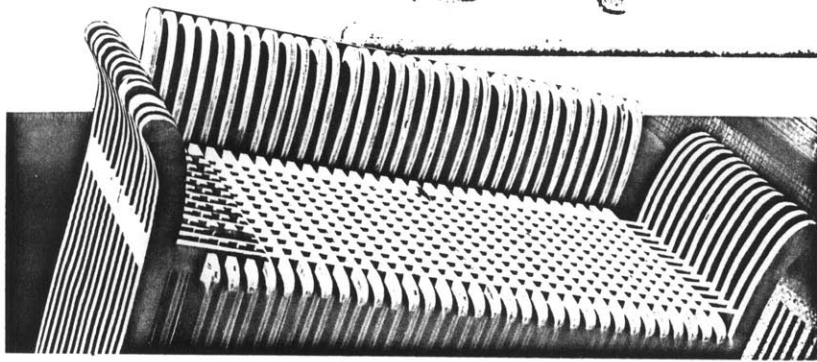
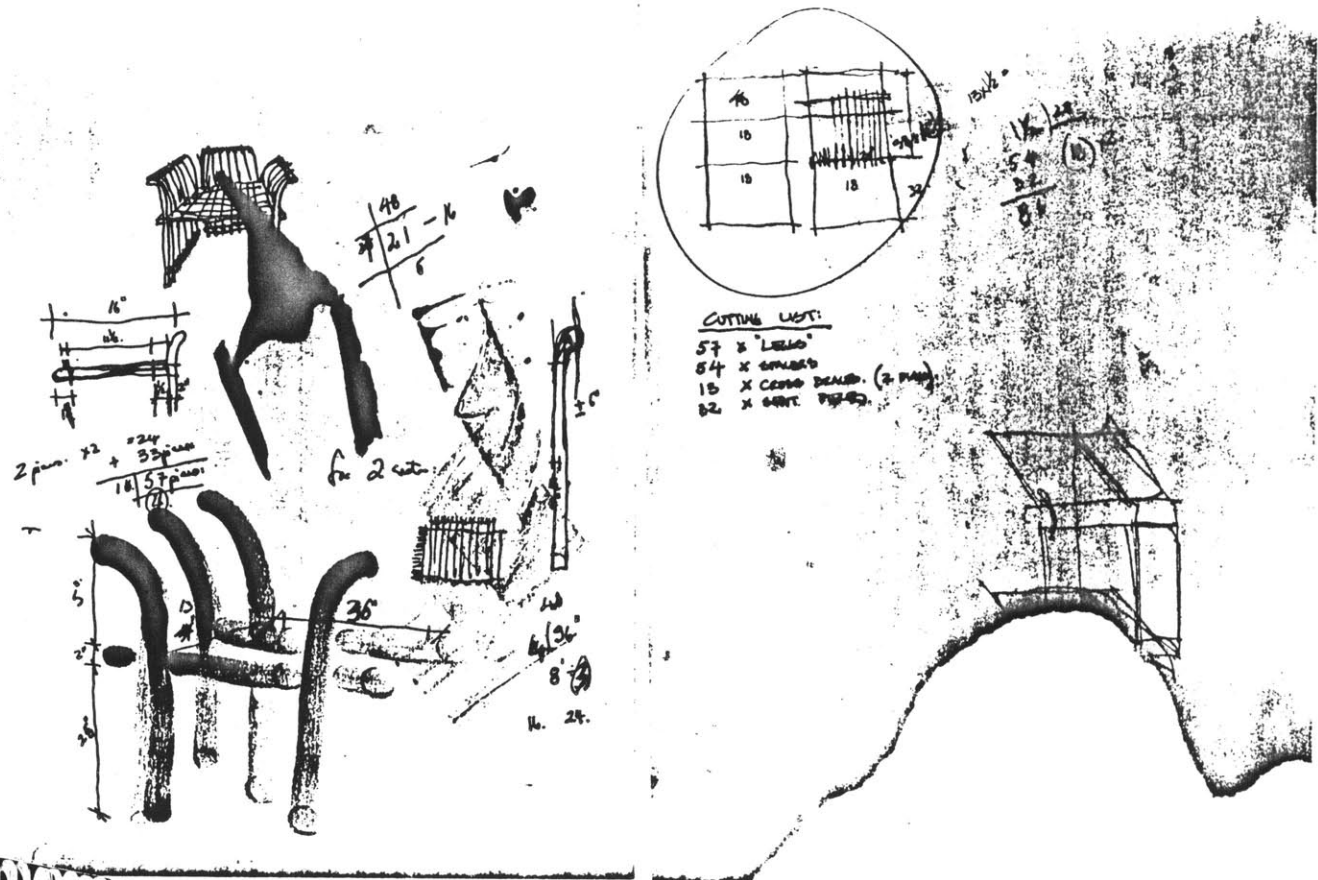

The chair was used in the workshop at a design, detail and pattern making board for a few months and proved a valuable addition to the shop's furniture. Then moved to a friends studio where it has used since on a daily basis, where it adds to the "sitsfleisch" of the impatient designer.



Cutting board

They use a lot of maple in this shop, and they waste a lot of it too, maple is regular grained very dense and durable, ideal for the making of butcher blocks and cutting boards and general kitchen utensils. So over a period of about three months i've collected offcuts from the rubbish bin. Today I squared up and planed them to a common thickness, and plan to use a bit of cascamite , if I can find any to laminate a whole bunch of them together.(Cascamite is a natural milk based waterproof glue) Trim the edges, scrape it to a suitable finish for my kitchen. I could do with a decent board, I have some nice knives, and cooking is a joy to me, this would just add to that.

There are a few common threads that link this to the work table and shelves, besides the basic material, and family of use, or the laminates all being of different widths, setting up similar rhythms to the slats in the table tops or shelf adjusting ladder of the shelves. One edge (due to irregularities which are probably not to healthy in a kitchen) has been trimmed with the slight wave form of the water snake.

But then it is just a simple no nonsense piece made robustly but with care and I'm sure it will be used the same way.

Home suite

So what are the things that we are designing? A whole suite of simple things for the home. Kitchen and studio stuff. There is something quite sensual, almost sexual about cooking, in its immediate rewards, a little more solid in doing design work, but they both relate to life very directly and there are lots and lots of parallels in the process. From shopping at the market, to a quiet dinner, and searching for materials to presenting the product for consumption.

The suite, designed for a good friend, so far consists of a chair, and a table already discussed and some shelves and a large work top, which sort of fit together, all made of junk, hopefully turned into some usable stuff. I know they are in good use.

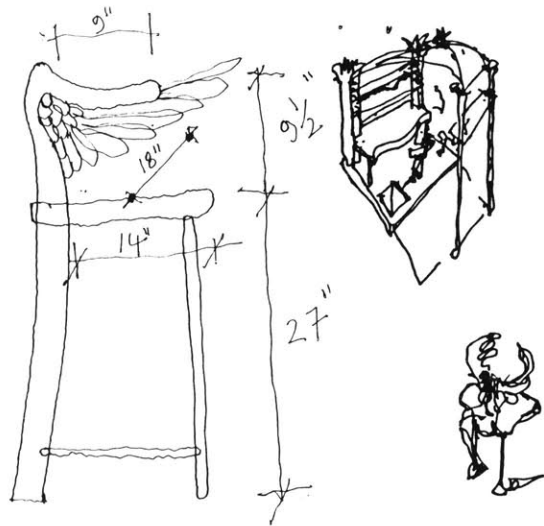

a wing backed chair
a chair for an aye
steady flat seat
wings up! and your
wishes support you in
comfort & ease while you
write.

the chair bones fill
into "rib" with many
rising from the seat, for
the passions of its maker.



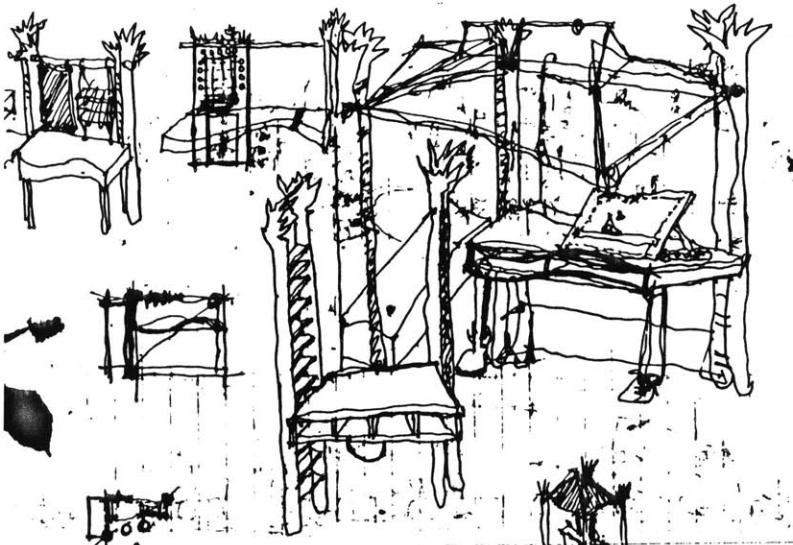

First thoughts, dreams, lying under a canopy of flowers you in a palm tree, rich dreams, dreams of wonder, thoughts of transportation, a desk, under the trees, amongst the flowers, shaded from the sun, a drawing board, a typewriter a lot of paper and pretty stones, hot sand, cool water, gentle shadows, and a sense of inspiration, a closeness to the elements, feet and fingers in the ground, eyes in the air, first thoughts of a place that I will build.

1. we choose a place
2. and possess it, by planting a tree
3. a pair of trees to mark its boundaries
4. build a pavilion to shelter in
5. and start to populate it with useful elements, things which carry identities
6. fill the place with the energies of one's soul
7. and transport you out of the place.

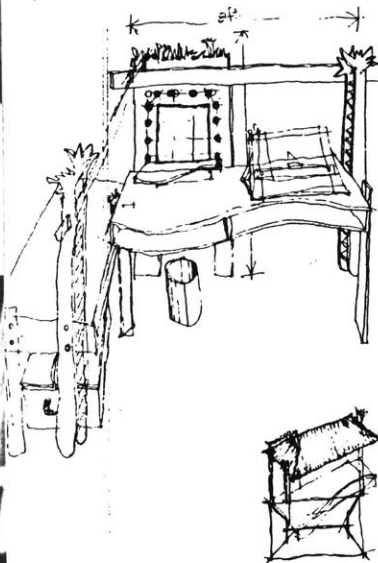

The idea of the suite was to build up a set of independent yet interrelated items which could be made individually and used immediately, each on their own. But would collect into a tailored work/living environment, one which could easily convert from kitchen to studio, dining room to office almost in an instant.

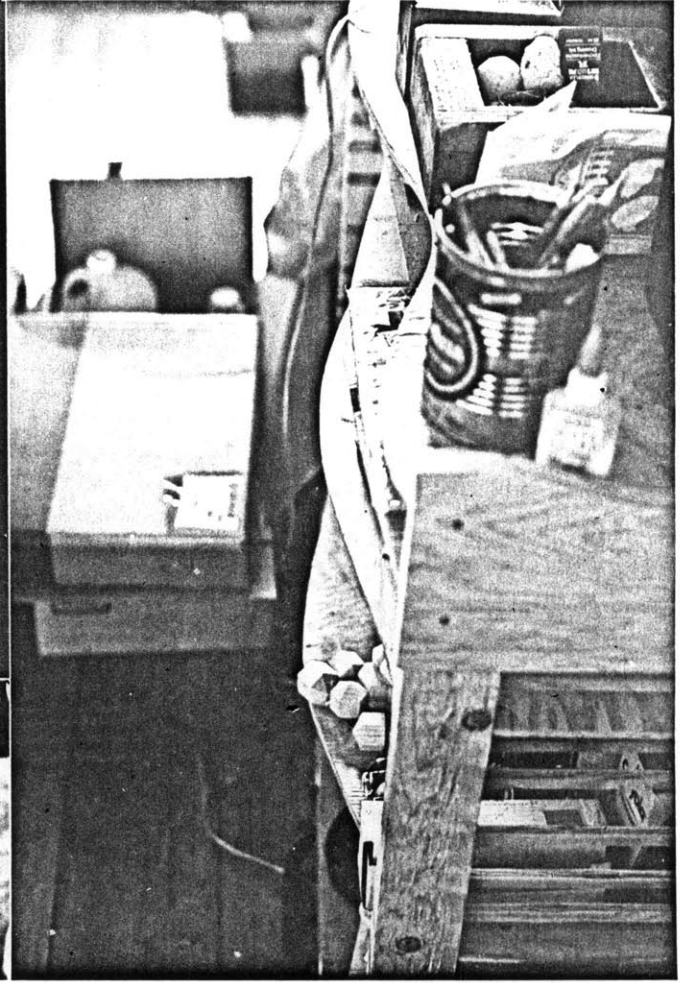
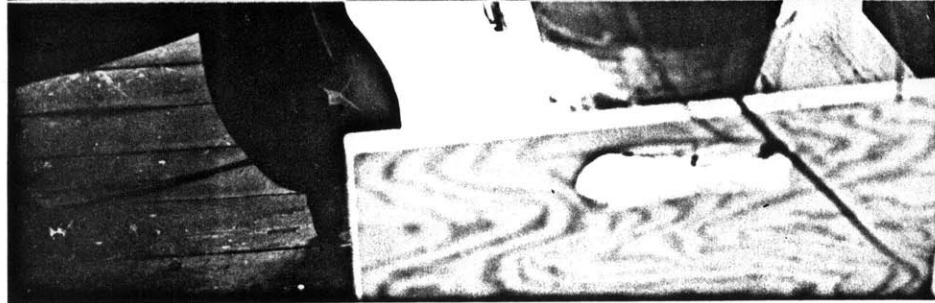

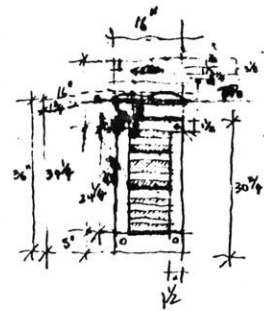
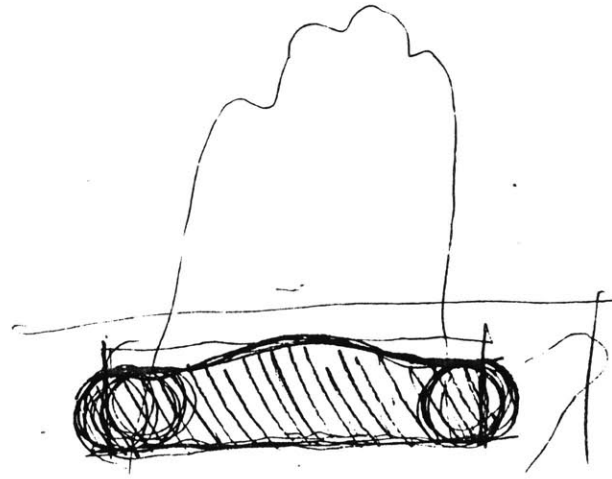
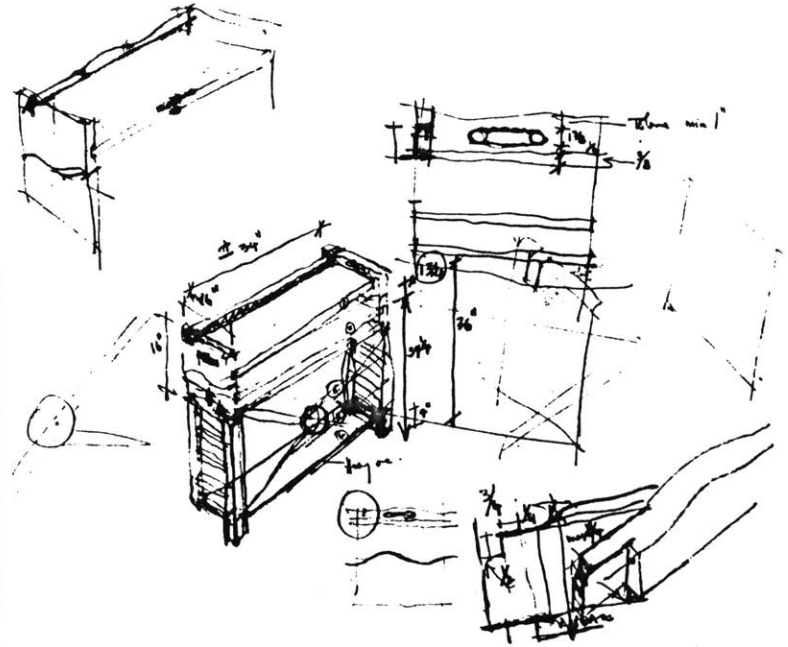

$$\begin{aligned} &= \sqrt{16^2 + 8^2} \\ &= \sqrt{266 + 64} \\ &= \sqrt{330} \\ &= 18.16 \\ &+ 8. \\ &= 26 \end{aligned}$$

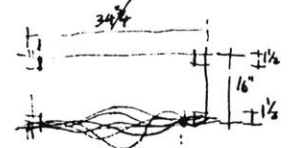



As the pieces are made over a long period of time and as the process of designing and making them was not a fixed one, they relate largely by the hand that made them and that they are all of recycled materials, and fit into the basic scheme of things. Also in that they are in turn lesson or exercises for the production of the following one.

The main lesson learned here is one of changing ideas as one goes, recording in a fixed way, by the products made.

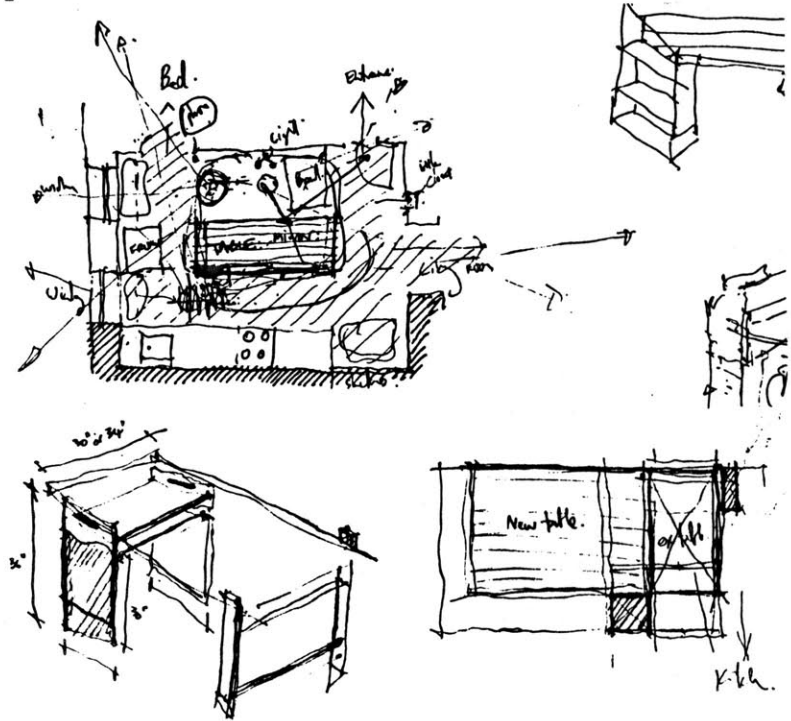



The sun
splits
and in its rays
inspired music.

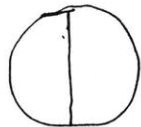

Music Stand

A piece of work sponsored by a generous friend. The first one is a gift for the wedding of two musicians.

I know from my work with David that our links formed between music and plastic arts where our work complimented each others by attacking different senses with common themes.

I was going to make a stand to put my tapes and player on but when Larry asked me to make him a wooden music stand a whole load of ideas started to grow (I wouldn't even dare to invent or make an instrument, probably the best thing to prove the points I wanted to, but this is a step)

My thoughts are tied to memories of David, writing in a garret back home, I wonder if as he played it would make a difference, the kind of stand his music stood on. I know that he uses ordinary paper, printed by the army, he used to be in the army band, and a very beautiful bakelite pen, Montblanche I think, with an engraved gold nib, heavy and light as it writes beautiful scores, just to look at, black ink. Accurate yet stylish, I

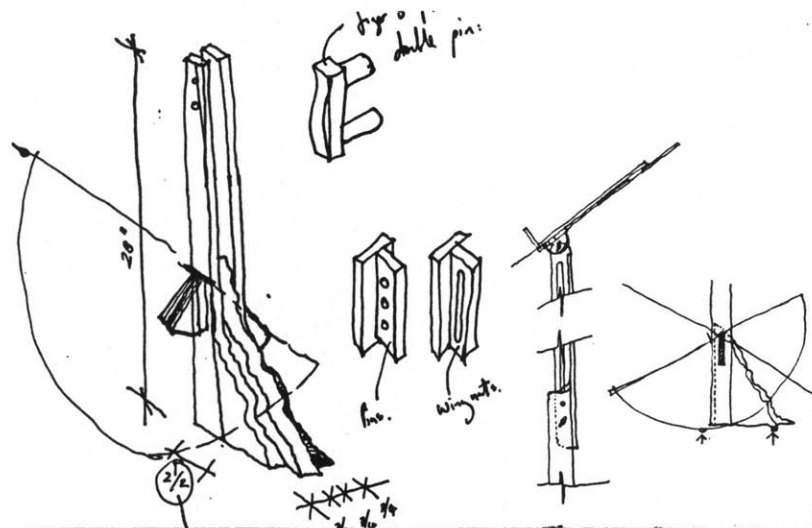

digress. The stand has its basic idea wrapped in memories from the time we met. I was working for the Living Arts Biennale, preparing an installation in winter, for a grey building. I built a beach.

In the three dimensional painting, was a house, a board walk, sand and sea, and two deck chairs made out of a split sun. That image of the split disk still occupies me, its shape and the tensions available when arranging and placing the two halves is constantly fascinating.

Aside; when making the two halves, they are both

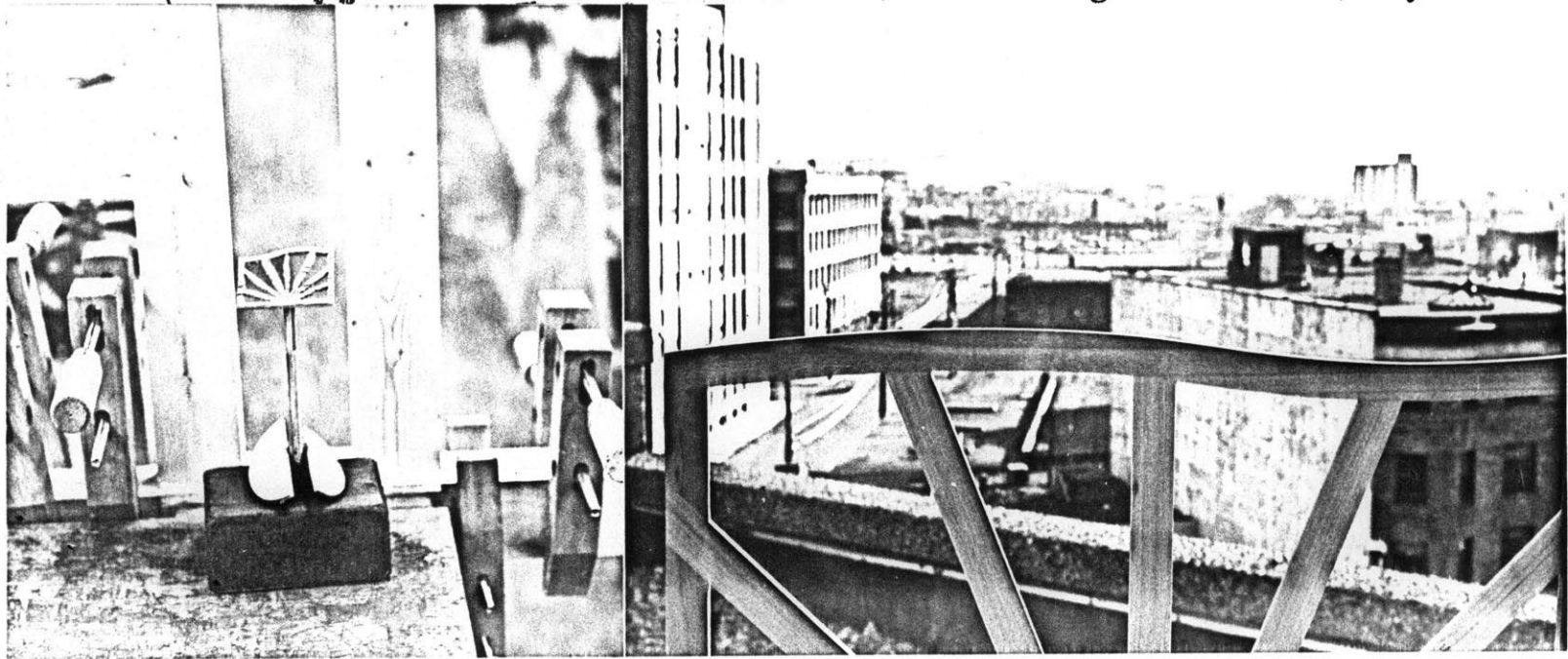

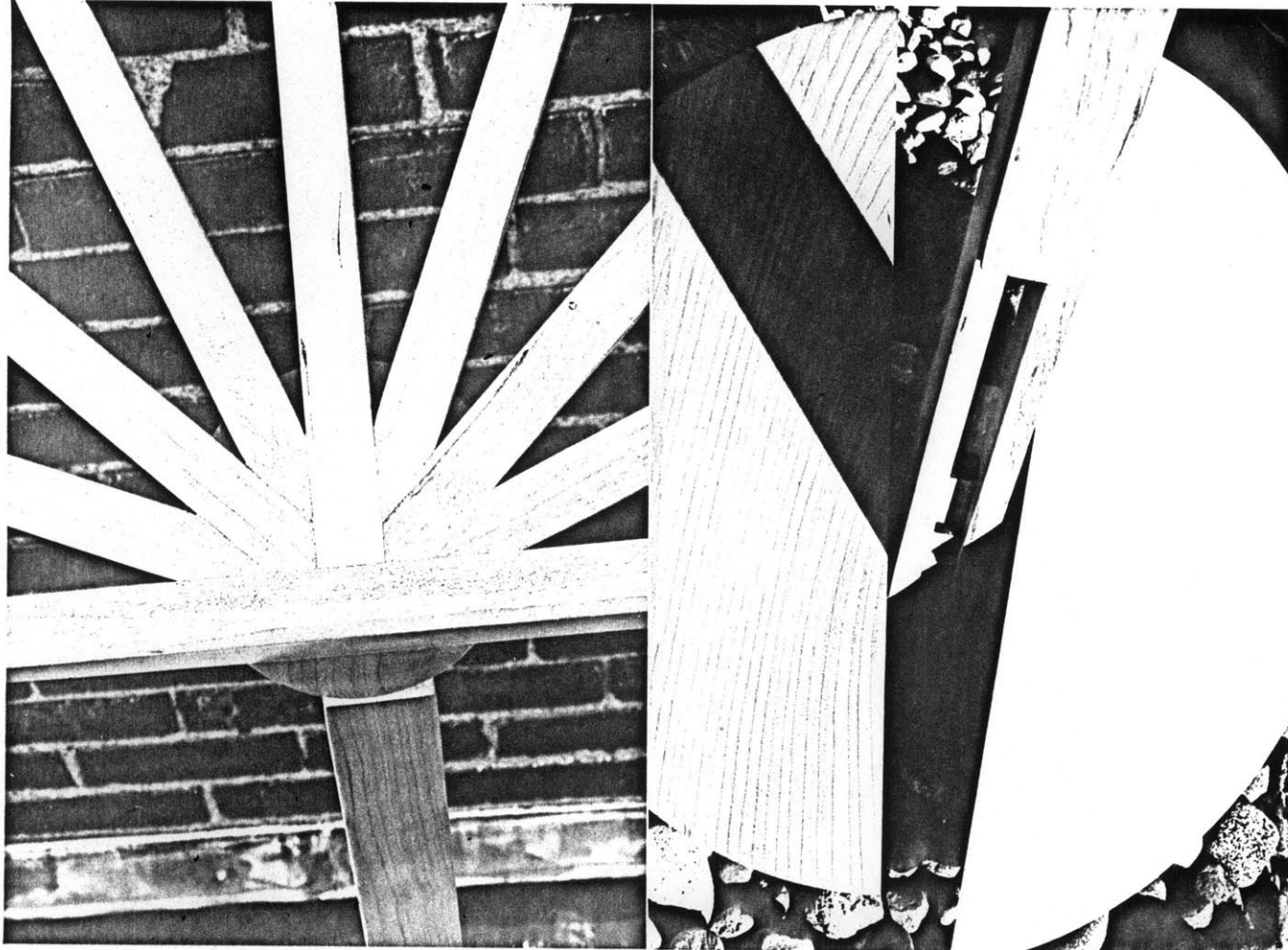

POUND CUTTING LIST:

- 2x 30" x 3/4" x 2 1/4" } val. 10.
- 2x 24" x 3/4" x 2 1/4" }
- 3x 12" x 3/4" x 8" }

- 6x 12" x 3/4" x 3/4" } sub. 10.
- 7x 15" x 1/2" x 3/4" }
- 2x 18" x 1/4" x 2 1/4" }
- 2x 2" x 1/4" }
- 2x 16" x 1/2" }

- 14 16" 1/2" }
- 12 4" x 3/4" }

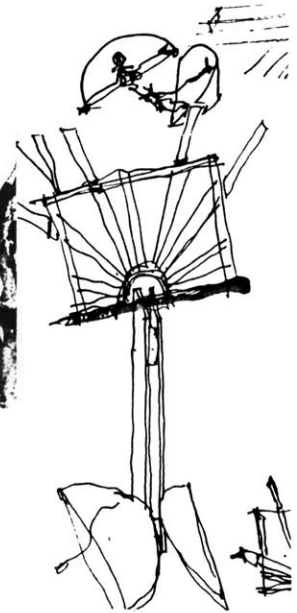

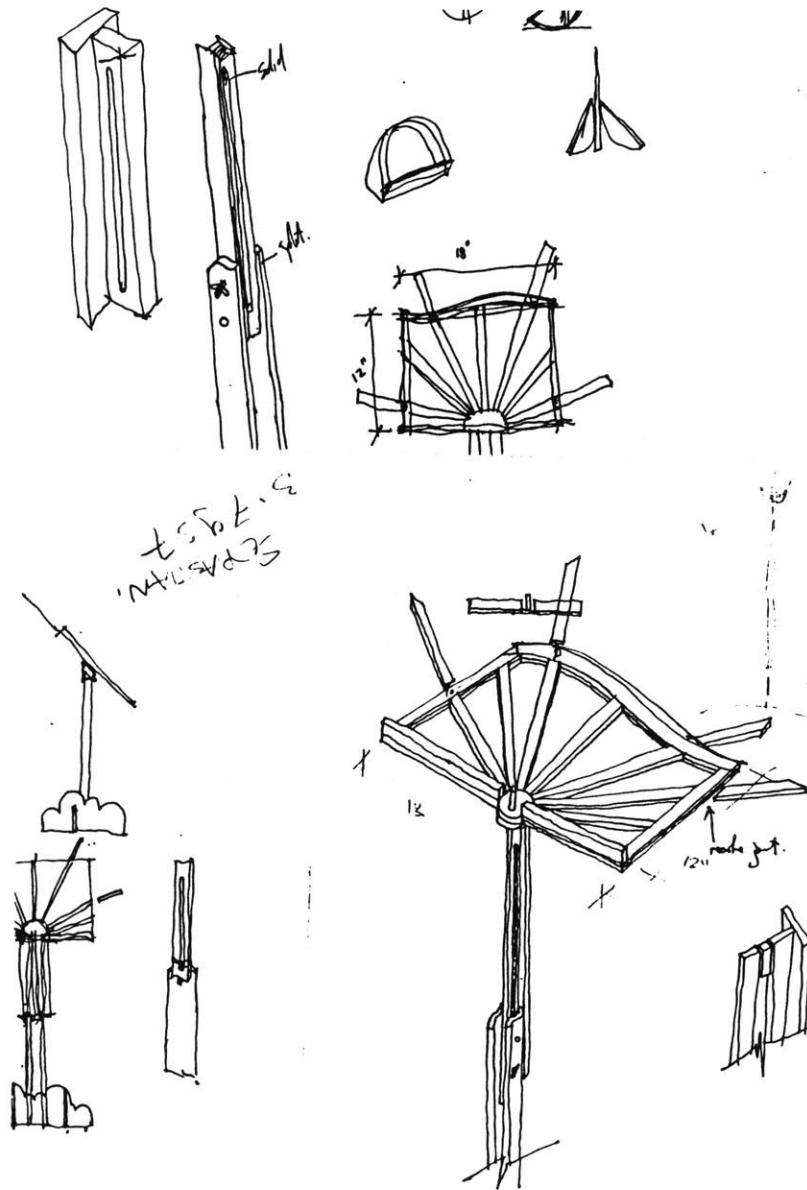

about a quarter of an inch bigger than half as the curve then looks more like a half than a true semi-circle does.

I could now afford a precious wood, cherry, and a few solid brass bolts, and the time involved in making was not quite as urgent.

The test was, could I use the semi loose approach to preparing drawings and refine the design in the making in conversation with the tools and materials.

I presented Larry with a rough model, and my sketches, and a few sample bits of wood, licked them to show the accented grain. He was excited. I started straight away, milling the timber to rough size, it felt too bulky not anywhere near elegant enough. I milled it down more and roughly assembled some of the bits with masking tape, selecting each piece for where it was to go with extreme care as to be structurally suitable and show off its grain best, within showing off the ideas of the design, subtly changing shapes here and there to suit the wood and how it might move with moisture and use. The only detail drawing to scale that I made were of the

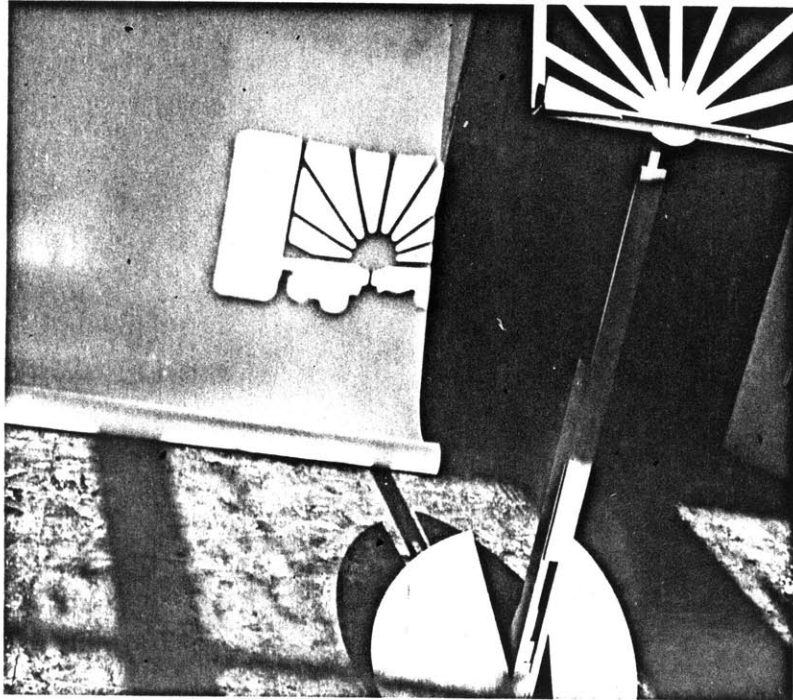

sunburst joint, as the tolerances to fit them were to be extremely fine. For the rest it was approximate size and size proportion and fit by eye, trial assembling and testing in mock use. Sebastian suggested more detail which made sense, and I developed the page holders. Final trial assembly, and then Lauren spent a night sanding and polishing the parts with me, prior to its final assembly.

Now there are a few bits to add again, and some details I'd like to change and improve, but it's been in use a while, and inquiries about making more of them are mounting up.

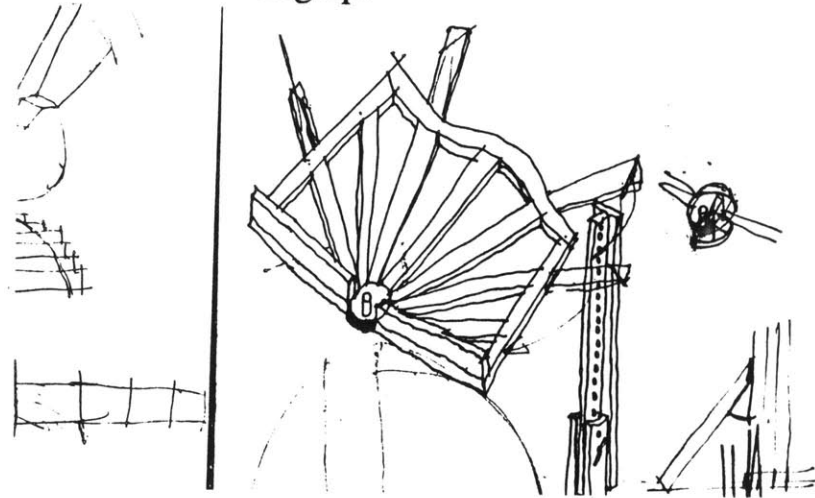

Conclusion

Reading about Joseph Cornell, drawing the sky and building boxes, making furniture, thinking of how to tie all this together, with the "Gesamtkunstwerk" and other environmental design notions. The fusion of dreams with reality, the translation of dreams into reality.

What I do know is that most of my work to date has been a set of ideas about making worlds, little worlds, I guess belonging to some kind of romantic tradition. Dreams of a world, not only the image, but how they might operate in a system that is fair and just.

My own area is design, thinking up not only the products of design but the whole life, a full dream of life, full, rich, intense, meaningful, connected, Ah! what a dream.

Translate this dream into reality, with out loss, but with additional richness at each level of translation, this was an exercise to prove that it at least in part is worth trying.

So what is this "Grand vision", Excellence, beyond all else.

I have started with blue and black drawings;

The black, to exorcise my dark history, the experiences of a soldier, of a bored middle class professional and a semi-successful artist,

The blue, like Miro, the color of dreams, White and Black, look
b a c k ,
blue, here's to you, the celestial blue of your eyes and Novalis's
magic flower.

These drawings were of the sky, and the stars, new constellations, new identities, links with the celestial, source of our religious mythology.

Then a ritual, of offering to the divas of the local forest and the city, drawn and built objects, in both the city and the country and transmit them to the other environment, as offerings and as an attempt to gain a connection with the earth in this place, make a boat, in small paper, an ark of ideas and cast it into the harbor, a cleansing pond. And thus we have the elements of air, earth, fire and water.

A set of drawings to which I think I might return to often to reinforce those identities, and from which to draw new strength.

I drew new constellations to summarise those identities, and they will act, I'm sure as icons to help invest meaning to other things later.

Let me briefly digress to the nature of design in this exercise. What I want to do is state how as one dreams, generating the ideas on which we base our worlds we start to express those dreams, a little

more solidly each time we review them, either in words or drawings or model them in some way. The dreams are about life, a good life.

The act of expressing each dream, each notion is in itself a ritual, a final act, a complete act, and therefore the "model" is a complete object in itself, referring back to the intentions of which it is the material expression, and forward to what it might become.

At this point I must clarify a point about materialism and spirituality, its pretty simple really. There are two parts to it, the first is that we gain our spiritual insights through transcending the material, this by mastering our relationship with making things. Making them almost in some form of ritual, filling them with meaning. The actual work, the craft, the intense connection with the material and its natural spirit help us transcend through it. The other is through an object richly made or selected, we can contemplate it use it, and gain from the joy imbued into it by its makers, an aid to transcendence, a mastery through use and ownership.

So we have some first intentions on paper, or some other kind of model, it is both complete as an artwork in itself, but it carries messages of far more, like - the love with which it was made, or its "working drawing" function.

More refinement of intent, drawings and models of greater clarity and final product keep going each stage or step gaining more richness, the key to this design notion is compliment, not compromise, and great care, even beyond what has been called suitability of care to purpose.

We now have a final object, to be given away or sold, distributed with its trail of other objects, as steps up the ladder to its creation, a documentation of its making as important as the final thing, all usable in some way.

Putting all this theory aside, what really counts is love in the production of things needed as items of simple everyday rituals.

Bibliography

- Giovani Brino: Carlo Mollino;Architecture as Autoboigraphy.
Rizzoli, New York. 1987
- Vincent T. CovelloThe Japanese Art of Stone Appreciation.
&Yuji Yoshimura Charles E.Tuttle Company,Rutland/Tokyo.1984
- Chris Fawcett The New Japanese House.Ritual and Antiritual,
Pattern and Dwelling
Granada Publishing Limited,London. 1980
- Chris H.GronemanTechnical Woodworking.
and Everett R. Mc Graw-Hill Book Company, New York. 1966
Glazener
- Philip and Phylis Powers of Ten, About the Relative Size Of
Morrison Things in the Universe.
and Charles and Scientific American Books,New York. 1982
Ray Eames
- Carol Robbins Selections from the Steven G. Alpert Collection
of Indonesian Textiles.
Dallas Museum of Art 1984

- Sarah Rosbach Feng Shui,
Hutchinson, London. 1983
- Jun'ichiro Tanizaki In Praise of Shaddows. Translated by Thomas
J. Harper and Edward G. Seidensticker.
Leete's Island Books, New Haven 1977
- Alan Windsor Peter Behrens Architect and Designer.
The Architectural Press, London 1981