

LIGHT-FORM: Reception
.....
Distribution of Direct Sun-Energy
.....

by
Donald W. Mills
Bachelor of Environmental Design
University of Colorado
Boulder, Colorado
December 1980

SUBMITTED TO THE DEPARTMENT OF ARCHITECTURE
IN PARTIAL FULFILLMENT OF THE REQUIREMENTS
OF THE DEGREE OF MASTER OF ARCHITECTURE AT
MASSACHUSETTS INSTITUTE OF TECHNOLOGY

February 1984

© Donald W. Mills 1984

The author hereby grants to M.I.T. permission to reproduce
and to distribute copies of this
thesis document in whole or in part.

Signature of author

Donald W. Mills January 20, 1984
Department of Architecture

Certified by

Maurice K. Smith
Prof. of Architecture A. Thesis Supervisor

Accepted by

Chester Sprague, Chairman
Departmental Committee for
Graduate Students

MASSACHUSETTS INSTITUTE OF TECHNOLOGY Rotch

APR 19 1984

LIBRARIES

01



Room 14-0551
77 Massachusetts Avenue
Cambridge, MA 02139
Ph: 617.253.2800
Email: docs@mit.edu
<http://libraries.mit.edu/docs>

DISCLAIMER OF QUALITY

Due to the condition of the original material, there are unavoidable flaws in this reproduction. We have made every effort possible to provide you with the best copy available. If you are dissatisfied with this product and find it unusable, please contact Document Services as soon as possible.

Thank you.

Poor grayscale image reproductions. This is the best copy available.



DEDICATION

... to Cindi ...

...for her

love

encouragement

patience ...

..LIGHT.-FORM:. Reception.. .

. Distribution of Direct Sun-Energy.

by

Donald W. Mills

Submitted to the Department of Architecture on January 20, 1984 in partial fulfillment of the requirements for the Degree of Master of Architecture.

ABSTRACT

The era of the energy-efficient building is upon us. You've heard all the terms before: solar, daylight, super-insulation and so on. These terms describe ways in which buildings respond to the presence of light. Light brings us heat, illumination, and an association with the world around us. But what more do we need to understand about light that will help us in the organization of buildings that are heated by it?

This thesis intends to bring to the surface a host of formal considerations that should be included in the energy discussion. As technological advances in the energy field continue, materials are improved and systems are refined while our attention to the formal implications of responding to light fades into the background. For the architect, an understanding of form should be of paramount concern and should not play second fiddle to advances in materials.

Within the following pages is the development of a formal understanding of light. It is the laying of a foundation upon which to build that expresses an attitude about light by looking-seeing-thinking in terms of form, hence the union of the two words: LIGHT-FORM.

This thesis is a beginning ... a journey of discovery that is fueled by taking a fresh look at the man-made (buildings) and the God-made (landscape) in terms of LIGHT-FORM.

Thesis Supervisor: Maurice Smith
Title: Professor of Architecture

TABLE OF CONTENTS

ACKNOWLEDGEMENTS	6
1. INTRODUCTION	8
some general facts of light-form...	
2. DYNAMICS OF LIGHT-HEAT	24
some principles of direct sun-energy...	
3. A RANGE OF FORMAL RESPONSES	50
a survey of references...	
3.1 From Cave to Pavilion	52
3.2 Zonal-Territorial	59
3.3 Wind-Climate	70
4.4 Collective Form	78
4. DESIGN VOCABULARY	90
sketch development...	
5. ASSOCIATIVE FORM OF LIGHT-DARK	124
some observations of light-form...	
6. EPILOGUE	158
a beginning...	
BIBLIOGRAPHY	166
FOOTNOTES	172
ILLUSTRATION CREDITS	176

ACKNOWLEDGEMENTS

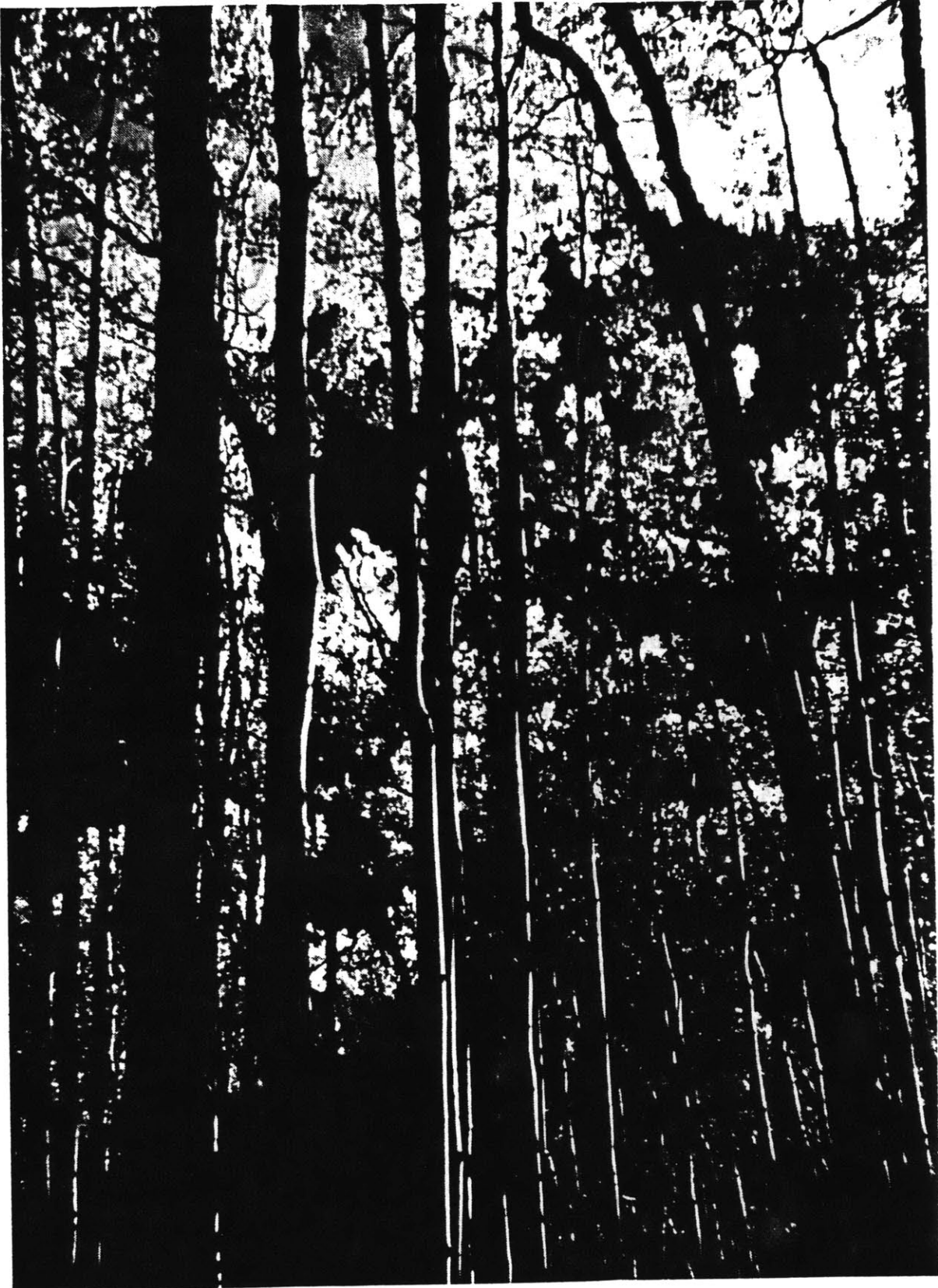

- ... The Lord Jesus Christ...

for loving me and teaching me the spiritual facts of light.
- ... Professor Maurice Smith...

for teaching me how to learn and how to see some of the physical facts of form.
- ... Long-time resident Rich Furman...

for being a good friend and for helping me to shift into the M.I.T. design-thought mode.
- ... The distinguished Dennis (Mr.) Carlberg...

for always being able to minister a choice blend of encouragement and criticism...and for his love of light.
- ... James Paul Hawkes...

for his prayerful support.
- ... Chester Sprague...

for trying so desperately to keep me on track during the proposal stage of this thesis.
- ... Timothy Johnson...

for his undaunted enthusiasm toward the blending of energy and architecture.
- ... C. J. ...

for some fantastik typi@ !!

1. INTRODUCTION

some general facts of light-form. . .

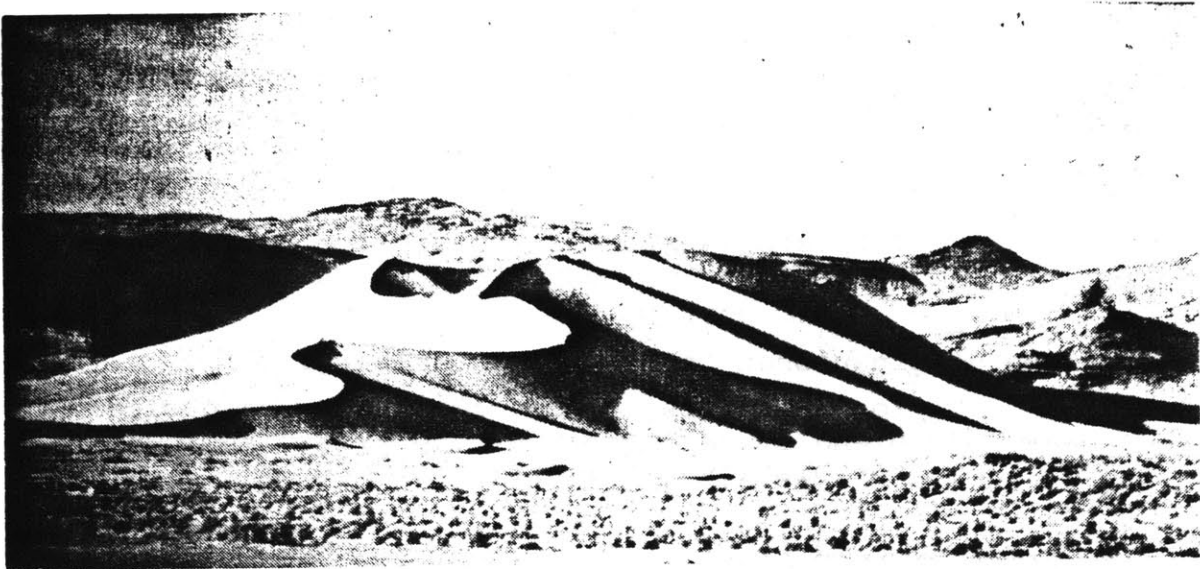

The teacher turned to his student and said:

"Light ... is!"

Moments before, the student had choked, sputtered, and fumed about his urge to know how to "use" light in buildings. He'd written a bit on solar design--the quantity and quality of light--and how best to put this stuff called light to work.

"How can I use light?" he'd asked.

"You can't," was the reply. "You can receive it or refuse it, but you can't use it. Light just 'is.' You can accept it or reject it; embrace it or reflect it; but you'll never get anywhere if you try to 'use' it."

So ... light is! We can be in it or out of it. We can move to it and through it. We can let it or not let it, but we'll never really use it. It just is.

Fine. Now what?

Well--if light is--then shadow must be also!

Precisely.

Okay. Now what is this light that is? What can we learn about it?

There's been a lot of talk about light in terms of both its physical and spiritual presence. The talk runs the gamut from the technical gymnastics of daylighting to artistic notions of form and space. Yes, there's been a lot of talk, and you are now involved with a bit more.

Why?

Because light is! If it wasn't, we wouldn't have much to say or see. So, since light is, we want--indeed we crave--to know of it and to be in it.

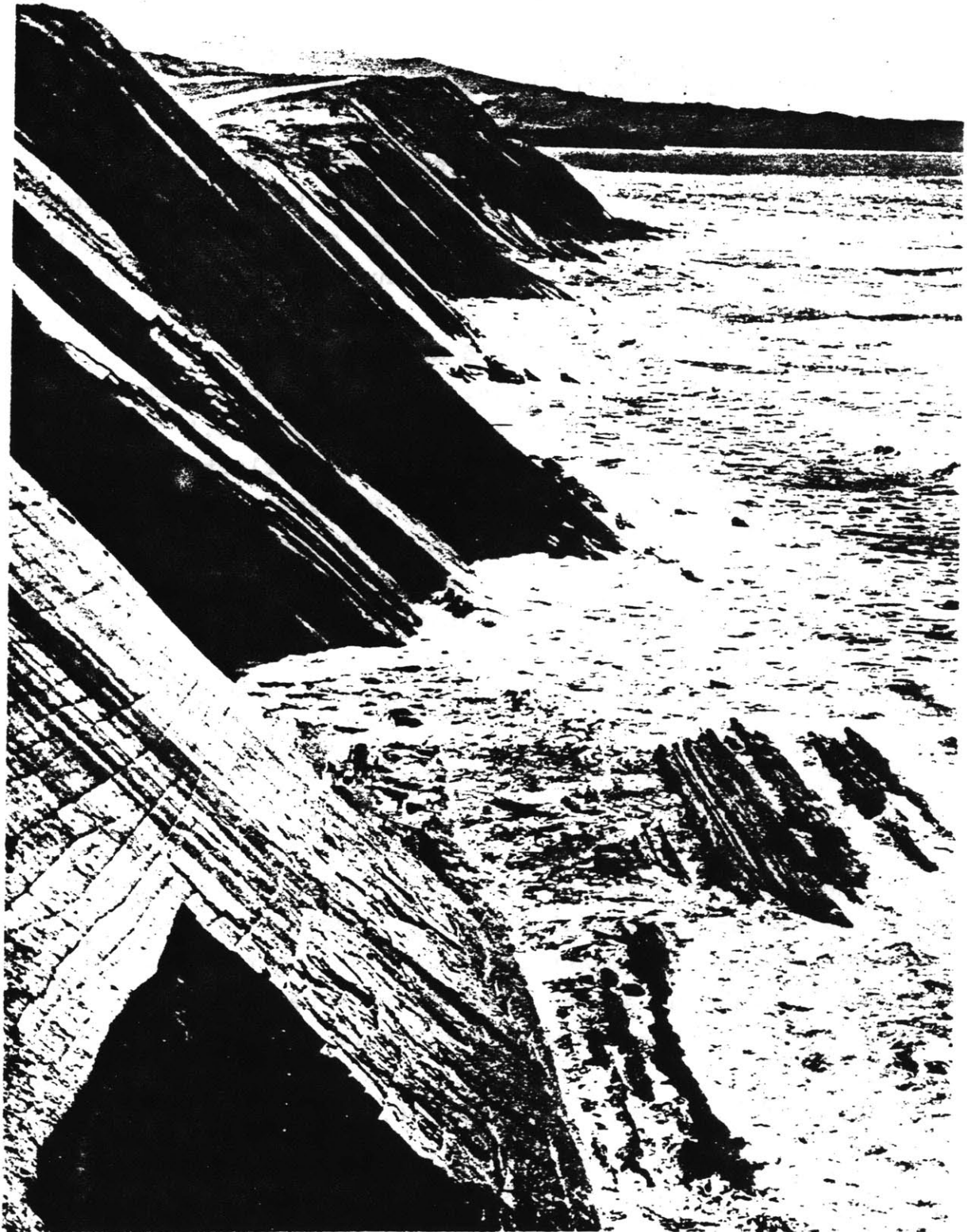

The divine task of creation began with light. The organization of water and ground--materials in light--didn't come until after there was light:

In the beginning God created the heaven and the earth.

And the earth was without form, and void; and darkness was upon the face of the deep. And the spirit of God moved upon the face of the waters.

And God said, Let there be light: and there was light.

And God saw the light, that it was good: and God divided the light from the darkness.

And God called the light Day, and the darkness he called Night. And the evening and the morning were the first day.¹

The light we receive from the sun exhibits certain physical characteristics that are phenomenal. In and of itself, light is transparent to our eyes. We see light, apart from its source, as it reflects off of surfaces. We call a leaf "green" because it is reflecting green while absorbing all the other colors of the spectrum.

We can see and also feel light. Part of the light we feel--the warmth of infrared radiation--is outside the range of our vision. So, the light we see is only a portion of the light that is!





Throughout time man has sensed that light carries with it more than meets the eye. Philosophers and architects alike have all formulated their ideas concerning the transcendental nature of luminosity.

Louis Kahn, one of the foremost advocates of light, proclaimed:

"Light is really the source of all being."²

Light brings with itself both physical and spiritual characteristics. Physical light gives us tangible information-- information to which architects should be especially sensitive. Le Corbusier stated that:

Architecture is the masterly, correct, and magnificent play of masses brought together in light. Our eyes are made to see forms in light; light and shade reveal these forms.³

The physical attributes of light are truly a wonder-- but what can we say of its spiritual qualities? Very few writers have managed to maintain a separation between the physical and spiritual presence of light. Light itself evokes such stirrings within us, making it difficult to separate that which is visible from that which is not.

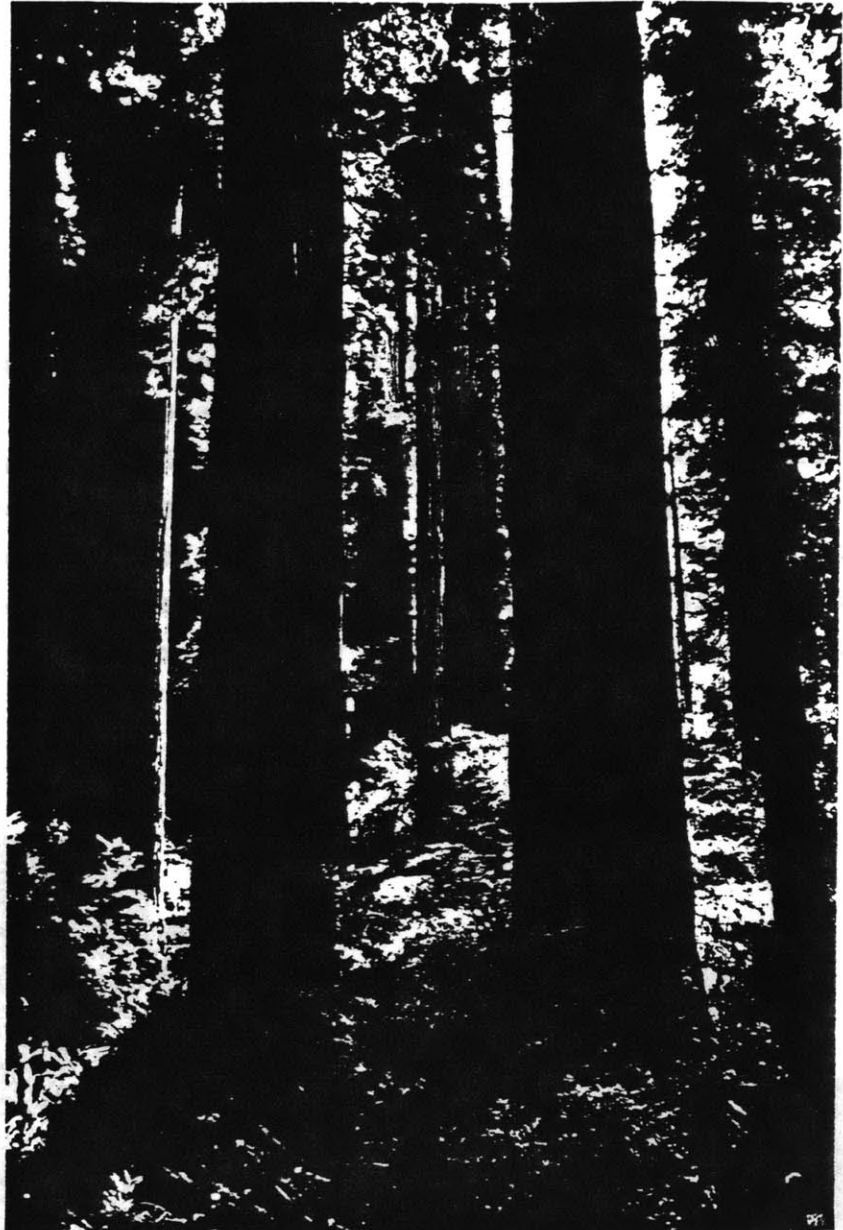

Frank Lloyd Wright demonstrated this inevitable mixing in his statement from A Testament:

As sunlight falls around a helpless thing, revealing form and countenance, so a corresponding light, of which the sun is a symbol, shines from the inspired work of mankind. This inner light is assurance that man's Architecture, Art and Religion are as one--its symbolic emblems. Then we may call humanity itself the light that never fails.⁴

We all sense some sort of divine light--"the light that never fails."

Most ancient civilizations worshipped some form of "sun-god." In Egyptian culture, Re was ordained as the supreme deity and dominating figure among the high gods. The Greeks claimed Apollo the sun god and patron of prophesy, music, and medicine. The Romans celebrated the Feast of the Unconquered Sun--Natalis Solis Invicti--every year on December 25th as the days lengthened following the winter solstice.



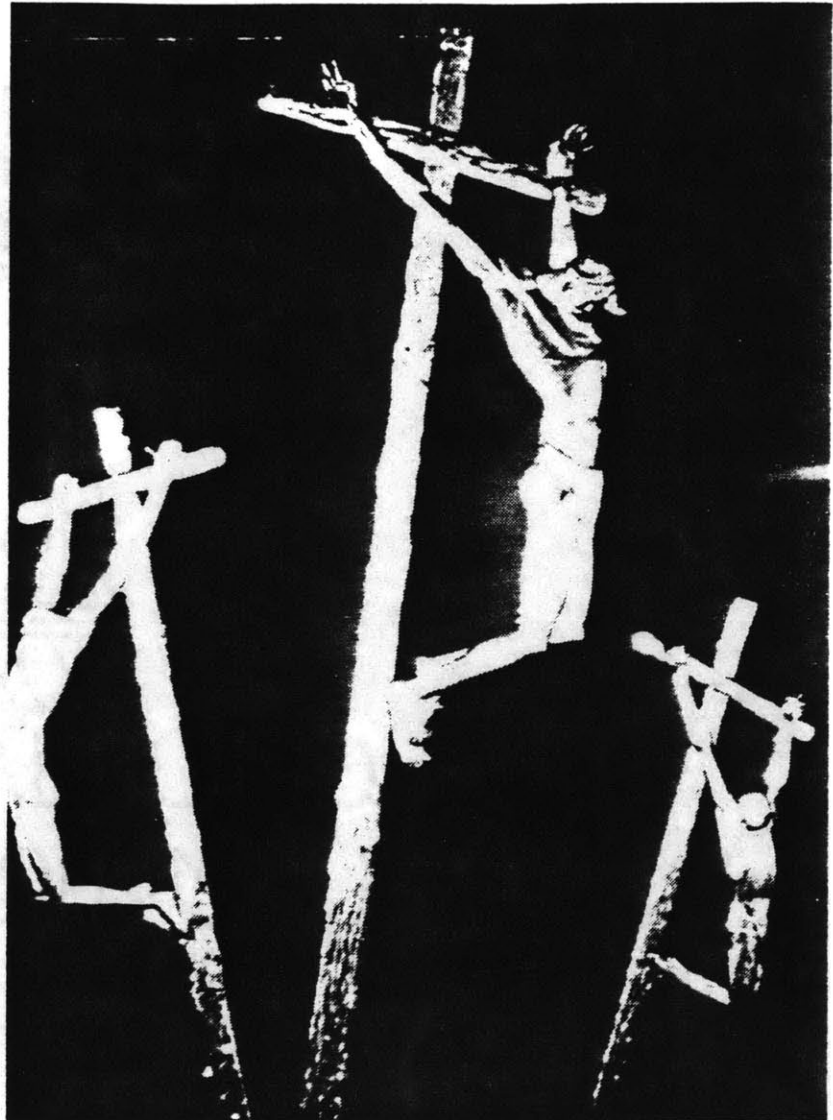

So many gods...all sharing the mystical spirit of light. Can we define spiritual light--or better yet--can it define itself? In the First Epistle of John we read:

"This then is the message we have heard of Him and declare unto you, that God is light, and in Him there is no darkness at all."⁵

The Gospel of John further reveals the nature of Jesus Christ as being "...the true Light which lighteth every man that cometh into the world. He was in the world, and the world was made by Him, and the world knew Him not."⁶

The true spiritual Light has revealed itself in the person of Jesus Christ or "God made manifest in the flesh."⁷



So, since "God is light,"
and...

Since "God is the builder of everything,"⁸ what can we learn from Him about building in physical light? The following passage illustrates the essential attributes of physical light and how we perceive it in the built environment:

TEMPORAL PERCEPTION

And God said, Let there be lights in the firmament of the heaven to divide the day from night;

DIRECTION ORIENTATION

and let them be for signs, and for seasons, and for days, and years:

ILLUMINATION

and let them be for lights in the firmament of the heaven to give light upon the earth: and it was so.

RANGE of : SIZE : FORM : USE

And God made two great lights; the greater light to rule the day, and the lesser light to rule the night: He made the stars also.

SPATIAL PERCEPTION

And God set them in the firmament of the heaven...

CONTRAST of : LIGHT : DARK

...to give light upon the earth, and to rule over the day and over the night, and to divide the light from the darkness: and God saw that it was good.⁹

Physical light conveys a wealth of information to us. We must work with this wealth that we have been given and avoid limiting our understanding of the many attributes of light.

One of the shortcomings of the recent push toward solar and energy-conserving architecture is that designs are often conceived with a limited view of light. If our main emphasis is to get heat and illumination from the sun, our buildings are likely to maximize those attributes of light while the others suffer. We can't just say--"solar!"--and expect our buildings to mean much more than that to us.

We need to add to the energy program a more complete understanding of light. We need to learn to observe the essence of LIGHT-FORM in both the God-built and the man-built landscapes.

FORM IS USE
 If 100 children can ^{see} ~~stop~~ ~~hear~~
 happily ~~use~~ ~~it~~
~~BETTER~~ ~~readily~~ on what ~~was~~ ~~called~~
 then that staircase is a ~~staircase~~ ~~thought~~ to be only
 assembly hall for those children ~~multi-purpose~~ ~~assembly~~ ~~hall~~ ~~floor~~
 they may ~~get~~ ~~others~~ ~~have~~ ~~already~~

- FORM = the structure or essential nature of anything.
- ≠ manners as governed by etiquette.
- = USE.

What is the relationship of the
man-built to the
God-built landscapes?

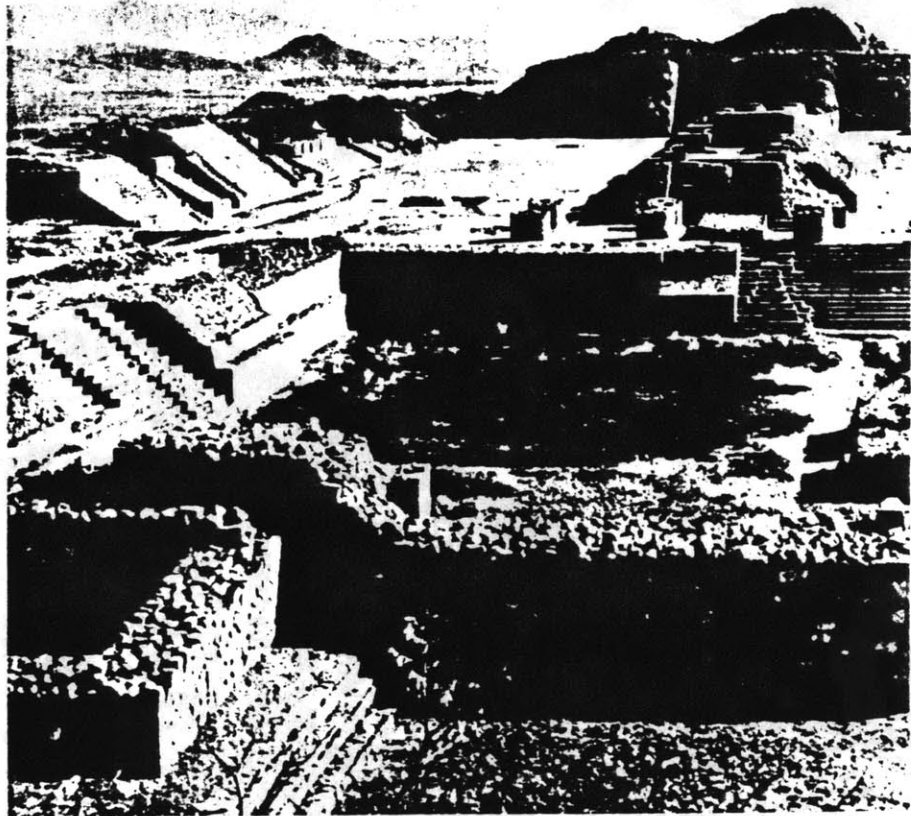

Is it to mimick as some have done?

...the vast majority of early civilizations...
Mesopotamian, Egyptian, Meso-American and so
on--fairly obviously set out to imitate natural
forms in their monumental buildings and to
geometricize them at landscape scale, so creat-
ing conscious images of mountain, sun's rays,
river, swamp, and cloud.¹⁰

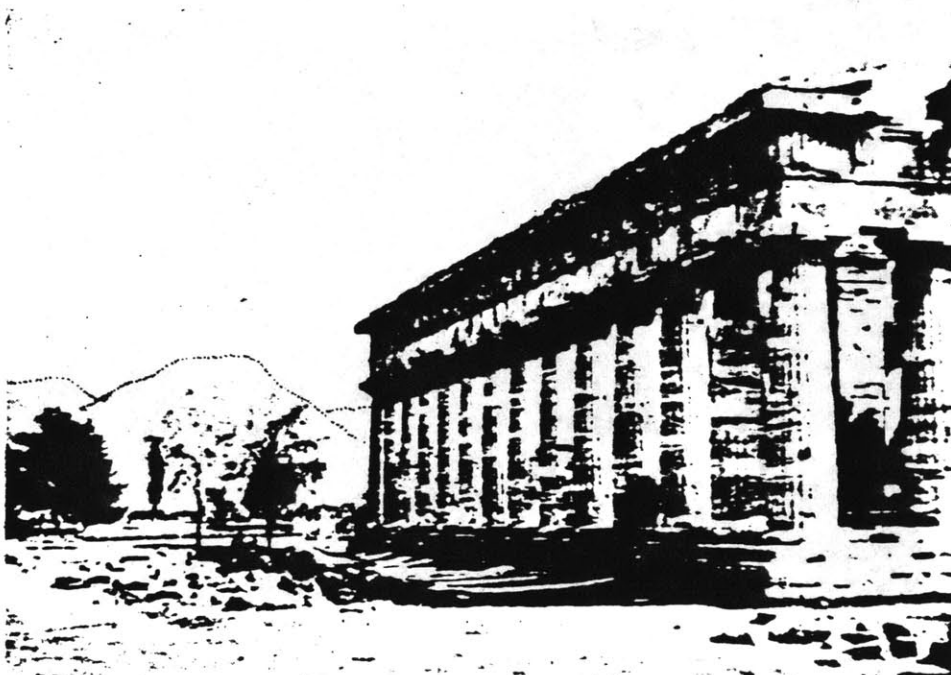

Is it to "complete" it as the Greeks have done?

His temples embody not the natural, but the man-conceived divinity. They are heroic; they confront and balance the earth's shapes but are not of them.¹¹

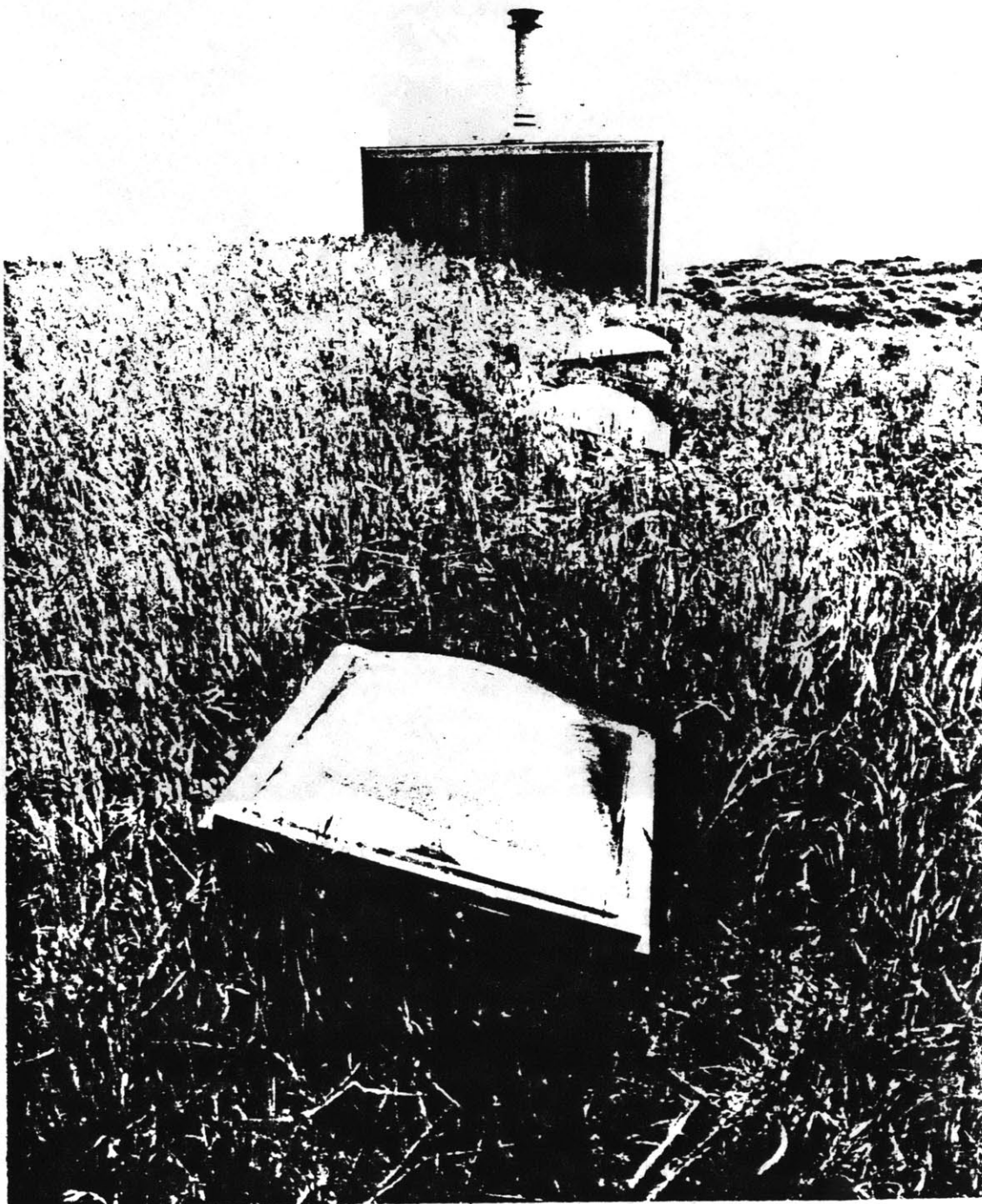

Is it to "blend in" with nature as some of the energy enthusiasts have done?

Gee, I think man is really an unwelcome visitor in such a pretty place as this and since we always mess up the landscape when we build in it maybe we'd better just bury our buildings and hope nobody notices that we're here.



Is it to "be" nature as the American Indians have done?

...the American Indian world is a place where no conception whatever of any difference between men and nature can exist, since there is in fact no discrimination between nature and man as such, but only an ineradicable instinct that all living things are one. And all are living: snake, mountain, cloud, eagles, and men.¹²

Is it to observe principles of LIGHT-FORM?

- not (exclusively) to mimick
- not (exclusively) to "complete"
- not (exclusively) to "blend in"
- not (exclusively) to "be"

...but to understand a range of formal responses to light, and then to work with and intensify that which we find in the

God-built
.....
man-built



FORM=USE

The energy reference award of the decade(s) goes out to the terraced dwellings of the American Pueblo Indians. Yet whenever a discussion of these places emerges, the same statement is always made:

"But they weren't built for that purpose!"

It's true, they weren't built (exclusively) for any singular purpose. So why are their buildings so persuasively useful for the "solar shape-hunters" of today?

The pueblos were built by men and women who were part of the landscape they inhabited. Their buildings reflect their way of life: they frame their lives. FORM=USE. Their response to the climate was, of course, appropriate technology. It could have been nothing less.

Meanwhile, modern man--full of technology and "wisdom"--tries to solve everything from an armchair with a computer. Better materials, better construction methods, better "this," and better "thats" don't guarantee a better built environment. We need to learn from God and from what He has given us; from man and from what he has built; by looking-seeing-thinking in terms of LIGHT-FORM.

"Anything will give up its secrets if you love it enough."

George Washington Carver

2. DYNAMICS OF LIGHT-HEAT

some principles of direct sun-energy. . .

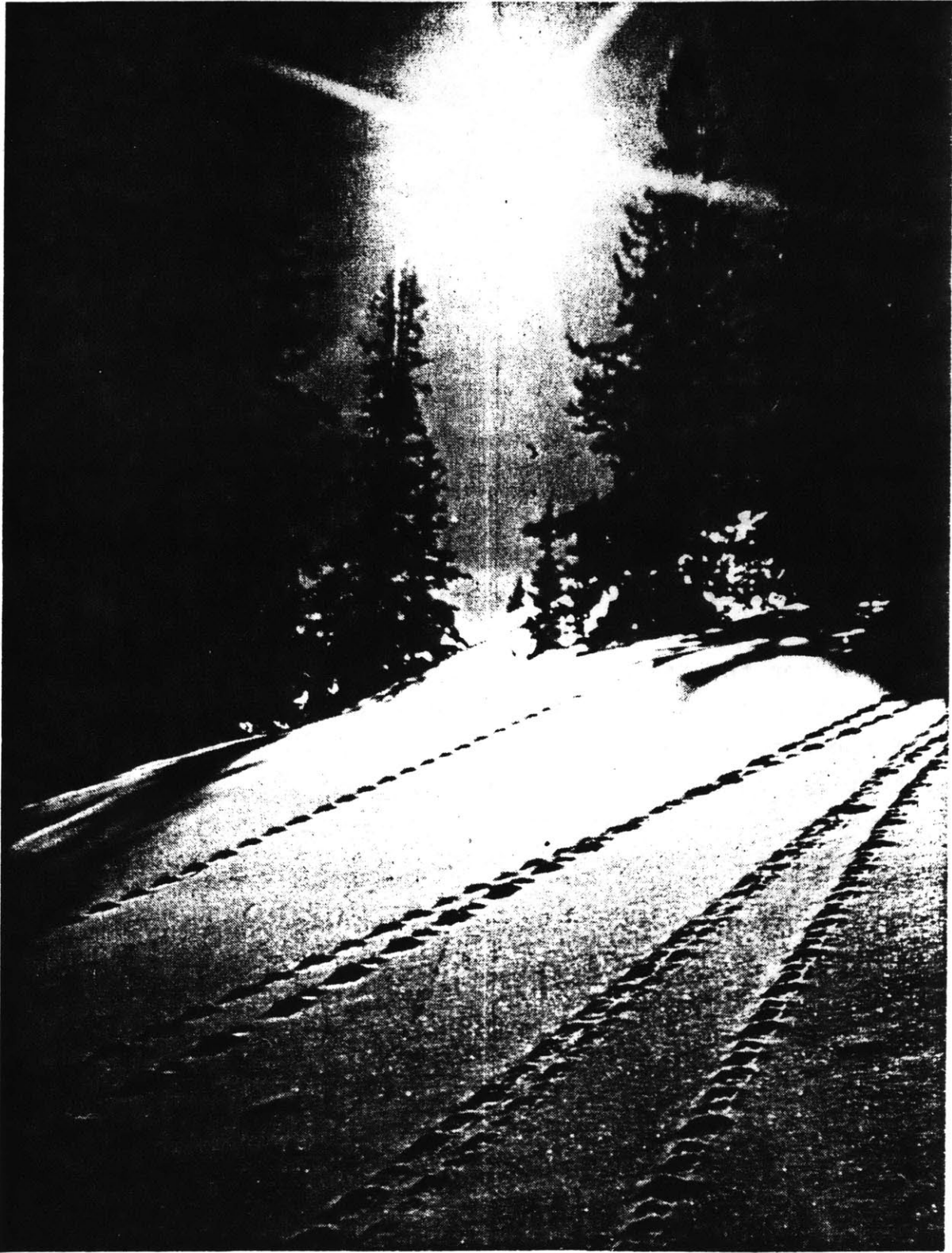

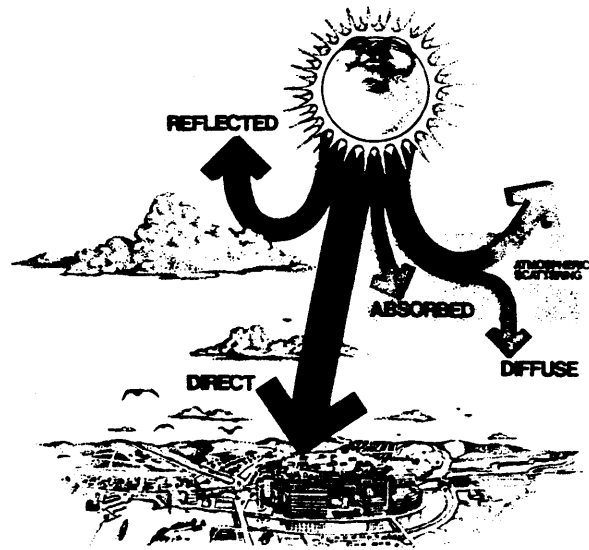

As light-heat travels into the Earth's atmosphere from our primary source--the sun--two parallel phenomena are at work. First, the light itself is transparent as it passes through "thin" air. We see only light that is reflected from surfaces: clouds ("thick" air), vegetation, materials, one another, etc. Second, just as light is invisible in air, it also does not heat air directly.

Air is transparent (at least over moderate distances of a few thousand feet), and heat from solar energy is produced only at the surfaces of energy absorbing objects. Air gets warm by convection, literally wafting over warm surfaces.¹³

When light strikes a surface, three events are possible. The light can be

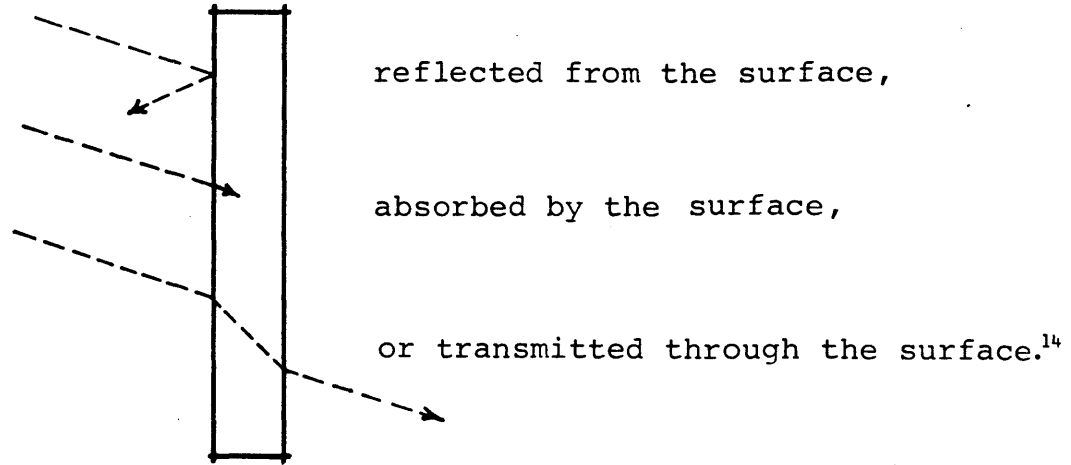

Reflection can occur within a range from a mirrored bounce (specular) to diffuse scattering. Absorption is related to color: if most of the light is absorbed, the surface will appear black; if most is reflected, it will appear white. Transmission of light occurs when a surface is transparent or translucent, allowing a percentage of the light to pass from one side of the surface to the other.

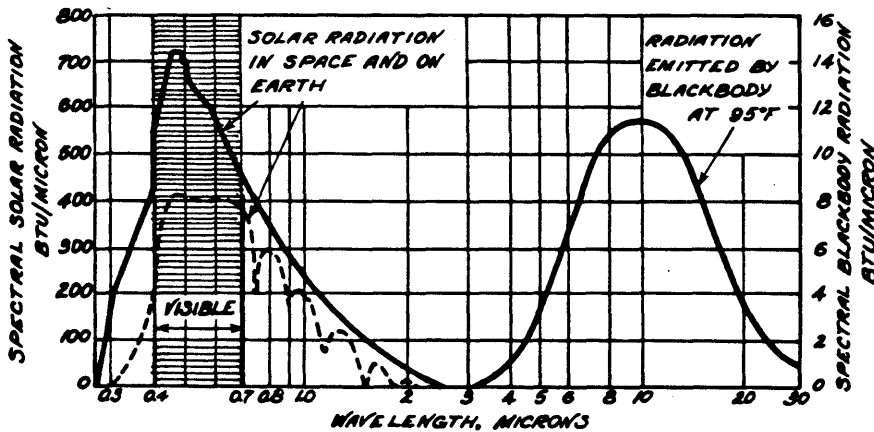

Only a portion of this incoming sunlight lies within our range of vision. The portion of light-heat that we cannot see is called infrared radiation. Approximately 49% of the energy available in sunlight lies within the near infrared region of the spectrum.¹⁵

As the light becomes heat at a sunlit surface, this light-heat moves through its surroundings in three ways.

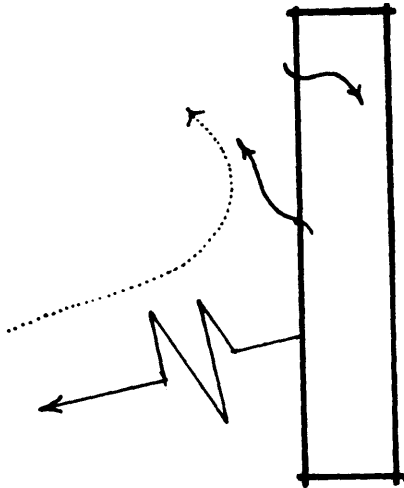

"Part of the energy will conduct into the material;

part will convect to the air;

and part will leave the surface as long-wave infrared radiation."¹⁶

The light-heat that conducts into the material will cause the temperature of the material to rise. The light-heat that convects to the air will cause the temperature of the air to rise. The light-heat that radiates as long-wave infrared will travel like shadowless light to cooler bodies of material in the surroundings. As multiple reflections of visible and invisible light-heat occur, multiple absorptions also occur until most of the sun-energy is absorbed into the surrounding surfaces.

Convection of light-heat into the surrounding air occurs in relation to the rate at which surfaces can absorb the available energy (emissivity). Air temperature begins to rise only when the incoming sun-energy cannot be fully absorbed by the surfaces it strikes. As air adjacent to a surface is heated, it rises and is replaced by cooler air molecules which are then heated, rise, and so on.. If this process is accelerated through the introduction of a breeze, heat is removed more rapidly from the surface. Wind is a deterrent to the absorption of solar energy as it literally strips heat away from the absorbing surface. The placement of a transmitting surface (such as glass) between the sun and the surface drastically reduces the heat loss due to convection.

So, the primary ingredients for making a habitable reception of direct sun-energy are:

glass and mass.

Glass is the transmitting surface and mass is the absorbing surface. These ingredients can also be discussed as the basic events in "harnessing" solar energy:

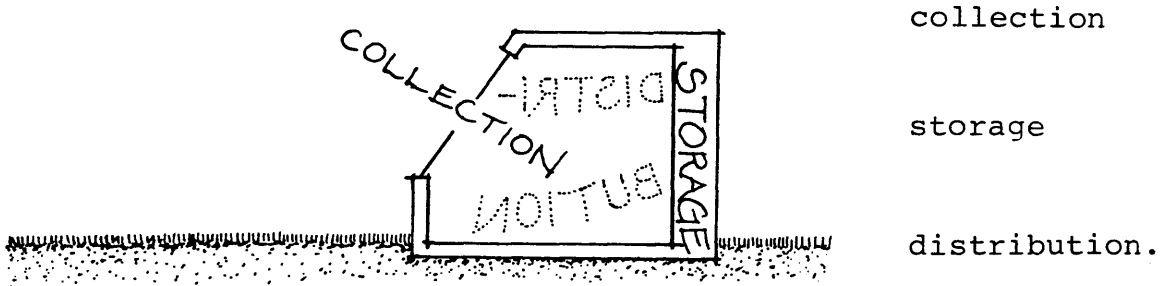

Light-heat is "collected" by allowing it an entrance into an enclosed space via transparent or translucent glazing. The majority of light-heat is available from the southern sky in the northern hemisphere and comes in the form of direct beam radiation. However, 10-20% of the total incoming radiation on a clear day is available as diffuse light from the sky vault.¹⁷ Therefore, the majority of traditional glazing systems will orient to the southern sky for the most efficient means of collection. Smaller amounts of glazing should occur in other orientations to collect diffuse radiation and to reduce the glare that would be associated with an unilateral light source.



With light on two sides and without

Light-heat is "stored" by the process of conductance/ absorption and infrared radiation mentioned earlier. All materials are able to store heat, but not all materials are able to store heat faster than they release it and thus prevent overheating of the inside air via convection. Materials deployable as "storage" are appropriately called thermal mass because of their ability to rapidly absorb sun-energy. These materials fall into three categories: masonry, containerized water, and phase-change salts. When placed in light, they soak up heat during the day and release it into the space at night ("distribution").

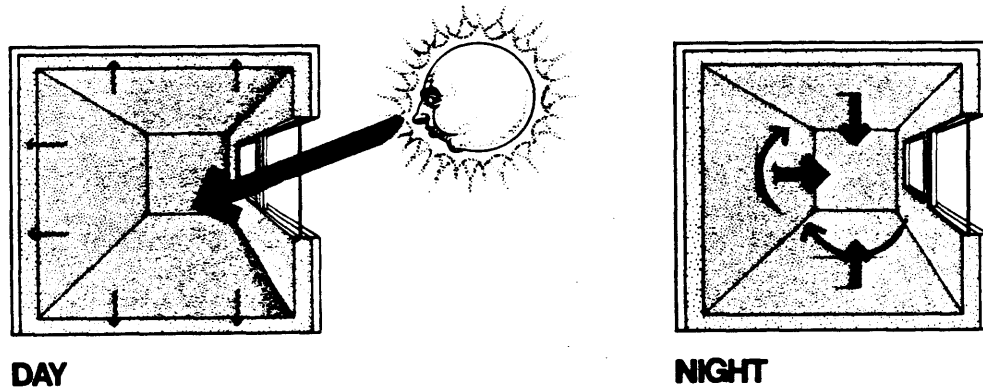

When choosing which material or combination of materials to use, various comparisons need to be made regarding their heat absorption properties and general characteristics as building materials. Tim Johnson devised a comparison based on a mass to glass area ratio that is summed up as follows:

MASONRY:

5-7 times the area of windows; off-white color;
5"-6" thick; diffused sunlight.

CONTAINERIZED WATER
& PHASE-CHANGE _____ :

1-3 times the area of windows; dark color; 5"
water/1" phase-change; direct sunlight.¹⁸

Water and phase-change materials are considerably more efficient in heat absorption than masonry.

As water is heated in light, the molecules move by natural convection and the entire volume of water raises in temperature together.

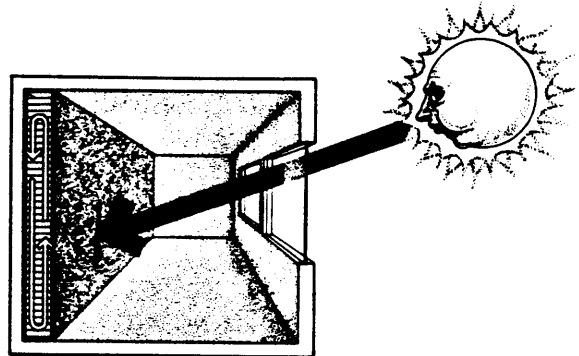

WATER:
HEATS BY CONVECTION.

Meanwhile, masonry is heated from its surface to its interior at a much slower rate. The miracle material, phase-change, has the advantage of storing a great amount of heat in a small volume plus the ability to absorb heat at a constant temperature. This material wins hands-down if only thermal properties are under consideration.

The next set of comparisons worthy of study (but mentioned only briefly here) are those of cost and use based on thermal performance. Masonry can be the structure of a building in addition to being its thermal mass. This makes it very attractive as a primary mass when you ask yourself how to build a structure out of water or eutectic salts. These latter two materials need something to contain them which could be structural material or not. Water needs special attention due to its wetness, weight, potential for harboring organic growth, etc.

Phase-change materials, on the other hand, are currently available in thin bags or tiles for application in the horizontal plane with promises of vertical application on the way. Though expensive, they could serve dual functions as surface finish and heat storage.

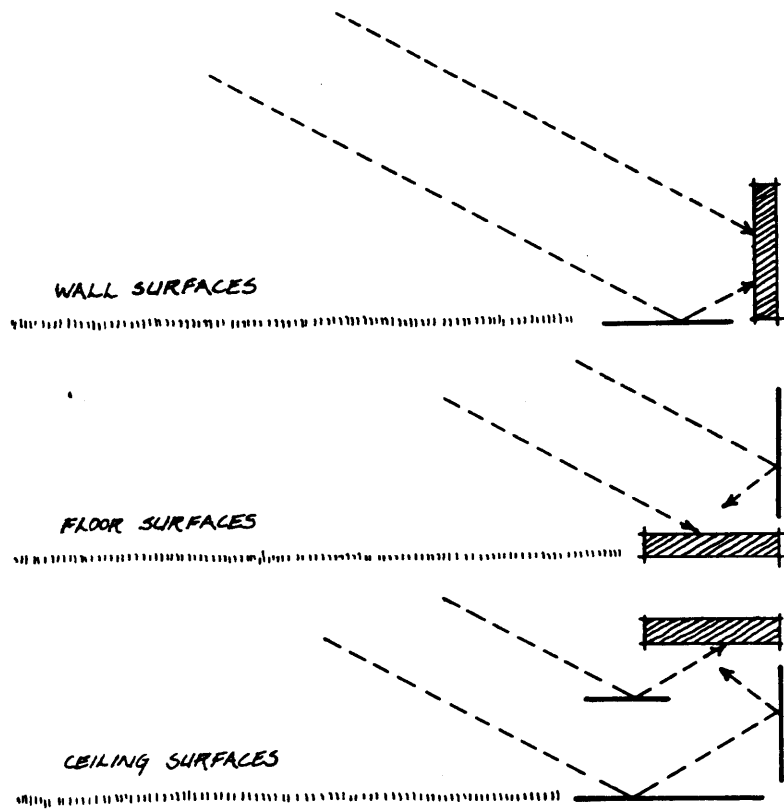

"TARGETS" FOR THE RECEPTION OF DIRECT SUN-ENERGY.

Heat absorbing materials are most effective when placed directly in the path of incoming light. Vertical wall surfaces respond well to low winter sun angles and to reflections off of horizontal surfaces. Floor surfaces are also prime targets for the reception of sun-energy. Ceilings are likely candidates as well if specular reflections direct the beam light upwards.

If a mass material is placed outside of the direct path of light, it can perform well as a secondary mass. The material will absorb infrared traffic and help to stabilize any potential rise in air temperature by picking up this "loose" energy. "Changes in room air temperature are reduced by 30% when the secondary mass area approaches the area of the mass in sunlight."¹⁹

The "distribution" of direct sun-energy to thermal mass is best achieved, according to both Tim Johnson and Edward Mazria, by illuminating a large, thin area of masonry. When a thick masonry section is the primary mass, heat absorption is slow and transfer of heat to the air by convection is high. This results in a rapid rise in air temperature, the thought of which produces sweat on this author's brow. Three methods of minimizing indoor temperature fluctuations by proper distribution of light-heat are recommended by Mazria:

Diffuse direct sunlight over the surface area of the masonry by using a translucent glazing material, by placing a number of small windows so that they admit sunlight in patches, or by reflecting direct sunlight off a light-colored interior surface first, thus diffusing it throughout the space.²⁰

"SPREADING" THE LIGHT:

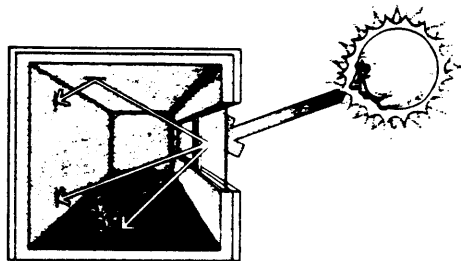

TRANSLUCENT GLAZING.

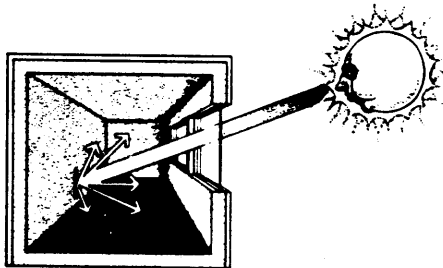

LIGHT-COLORED SURFACE.

When a large area of mass is warmed by one of these diffusing methods of distribution, that same area radiates heat back into the space when the sun has gone down.



COMFORT - FORM

A primary goal in making thermally efficient buildings is to provide for human comfort. The goal should never rest in the dynamics of energy systems without having the thermal and visual comfort of the inhabitants as the basis for all decisions. We're not out to build a better solar oven, we're out to build comfortable environments.

The previous pages of discussion have focused on the dynamics of light-heat and its reception-distribution. The following pages of discussion in this section will elaborate on issues of comfort-form and their diagrammatic descriptions. All of the text and illustrations are intended to expose "principles" of LIGHT-FORM rather than to devise "rules of thumb." Understanding principles is far more valuable than elaborating on rules of thumb.

The critical test of any rule is related to its specific application. Whether a rule works or not depends on its relationship to other rules: thumb will work, thumb might not. While one rule of thumb might work in a particular instance, the same rule might not work in a similar application. The right thumb may not know what the left thumb is doing, and vice versa.

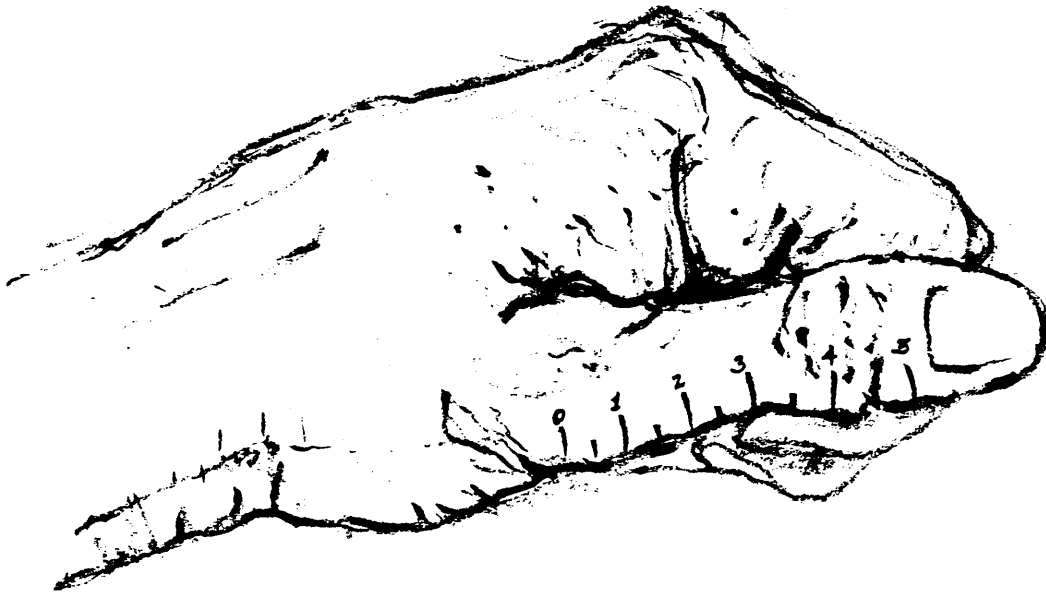

A thumb is only useful when connected to the hand--I'd rather have a hand without a good thumb than a handless thumb. What good is a thumb, as a rule, if it is attached to an otherwise empty wrist? For that matter, what good is a hand full of thumbs? Since thumbs don't work together very well without the accompaniment of other fingers, perhaps we need one rule of thumb, one rule of index finger, one rule of middle finger, and so on in order to establish the working relationship between the various rules. Or, we could limit the number of rules of thumb to two--one per hand--in order to avoid being all thumbs. However, when more than one person is involved, like in a "hands-on" project, the number of rules of thumb (two per participant) could easily get out of hand. Therefore, it would seem easier to have only one rule of thumb, which would be: beware of rules of thumb.

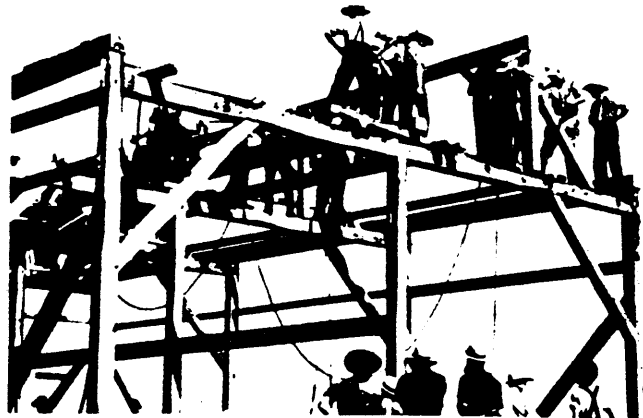

So, that brings us back to the discussion of principles. It's important to understand the behavior of systems and how variables interact so that reasonable design decisions can be made. In terms of comfort, it's important to understand that "we are comfortable thermally when our bodies are in thermal equilibrium with our environment."²¹

In a cold climate, the first place to begin improving the level of comfort is at the site. As you walk through a wintry landscape, it's interesting to note the different microclimates that occur there. Some places--open to the sun and shielded from the wind--are considerably warmer and more comfortable than nearby places that may be shaded and wind-blown. The overall climate could be constant during this walk, yet the microclimate of each particular site would vary greatly.

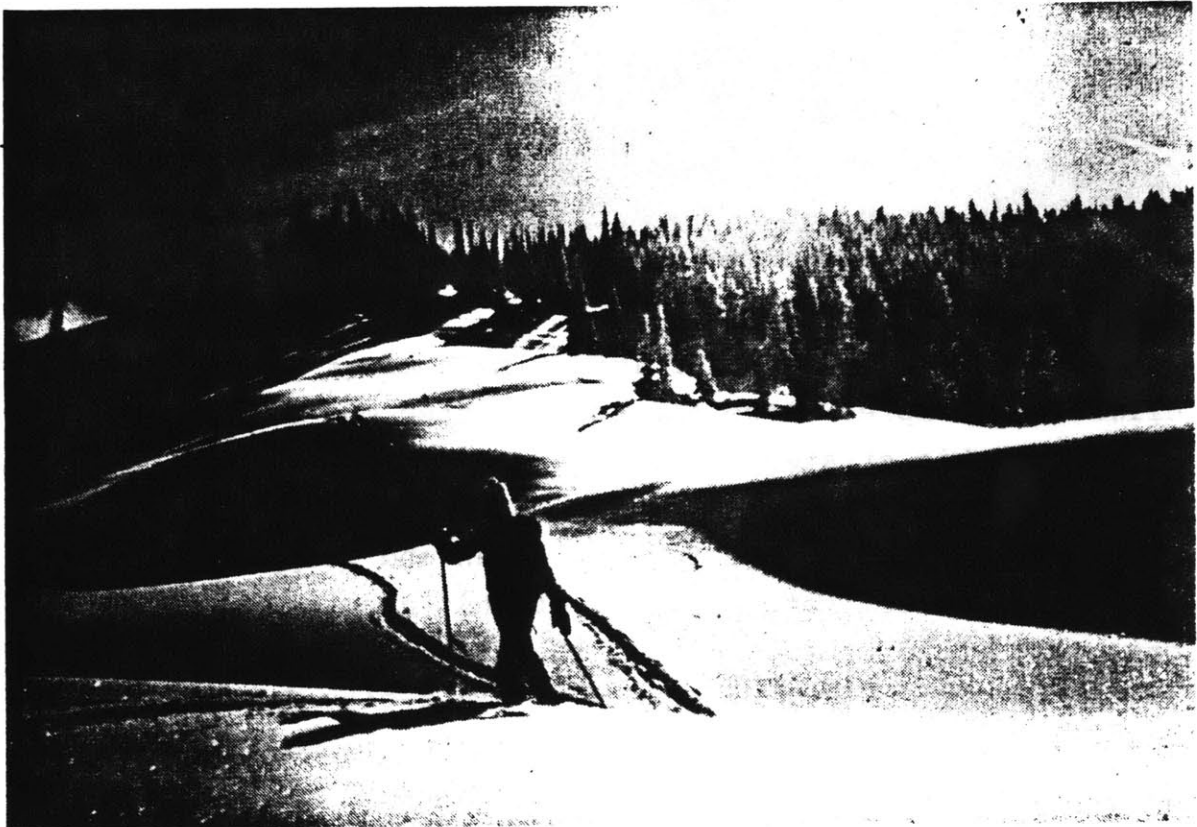

Our perceived level of comfort is controlled by the way in which the sun, vegetation, and topography work together to affect the air temperature, humidity, and wind.²² By understanding the interaction of these variables, we can build comfortable environments for both ourselves and our buildings.



The basic strategy for improving comfort in a cold, sunny climate is simple: face the sun and step out of the wind. If we follow this strategy at all sizes in the built world, we'll be on the right track. For example, if the smallest entry court or private terrace faced the sun and stepped out of the wind, the microclimate in front of that door or in that seating place would be warmer than the macroclimate. Similarly, if the largest outdoor public space in a city faced the sun and stepped out of the wind, people would be more likely to gather there.

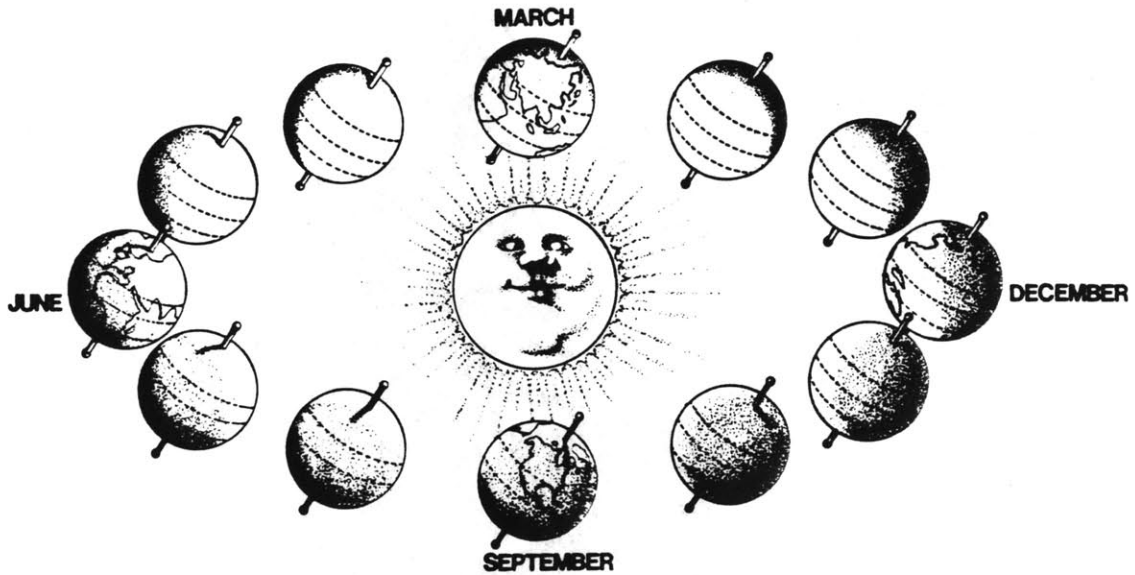

In the summer months, the comfort criteria reverses--we want to step into the wind and out of the sun. Does this mean we need to change the orientation of our buildings and make seasonal adjustments in our vegetation and topography? Of course not--the Lord has already done most of the work for us by changing the path of the sun across our sky, shifting the direction of the wind, and clothing bare branches with leaves again. The only work required of us is to intensify these seasonal differences by making winter sun traps/wind blocks that double as summer shady spots/breezeways. This applies within our outdoor spaces as well as our indoor spaces.

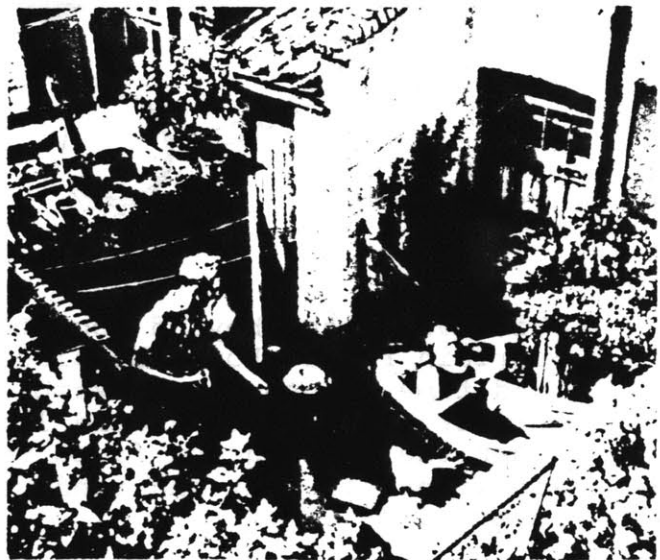

Socrates: "In houses that look toward the south, the sun penetrates the portico in winter, while in summer the path of the sun is right over our heads and above the roof so that there is shade." ²³

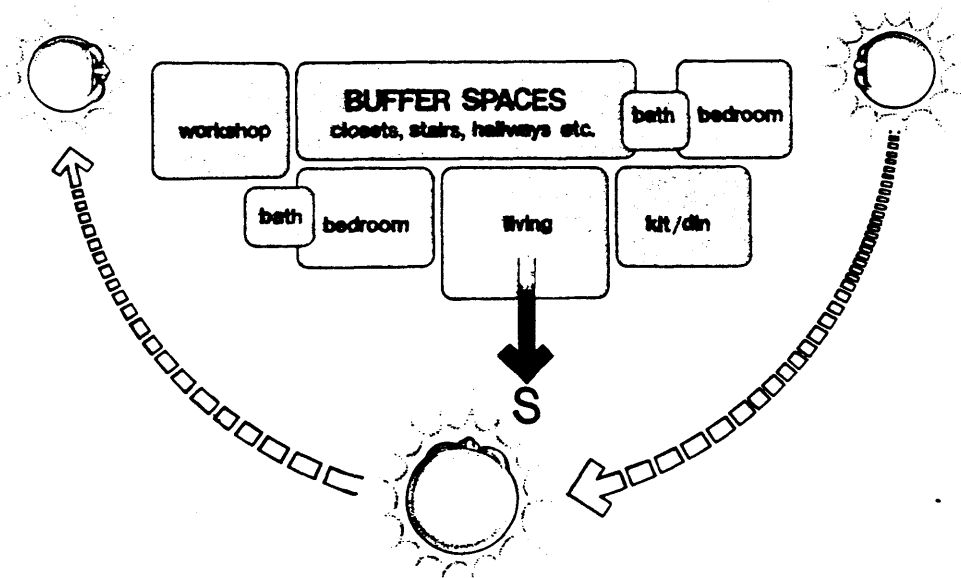
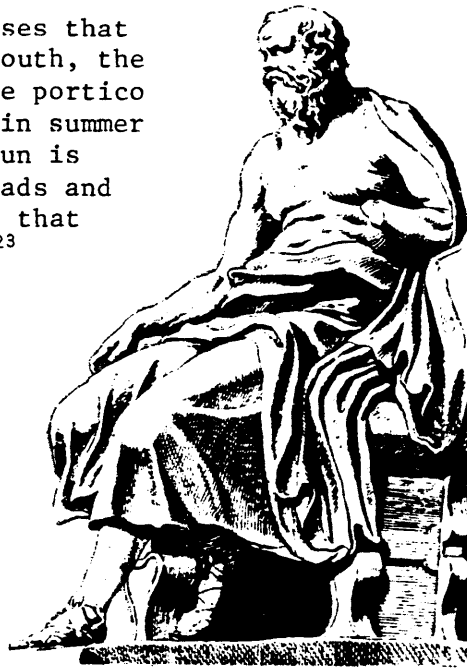

Vitruvius went beyond Socrates, and recommended where certain rooms should be placed in relation to the sun and time of use. For example (not illustrated), the winter dining room should look to the west "because when the setting sun faces us with all its splendor, it gives off heat and renders this area warmer in the evening." ²⁴



"A building elongated along the east-west axis will expose more surface area to the south during the winter for the collection of solar radiation. This is also the most efficient shape, in all climates, for minimizing heating requirements in the winter and cooling in the summer."²⁵ A collection of buildings, i.e., a street, should also elongate along the east-west axis.

Right: The plan of Acoma indicates that most of the dwellings were grouped in long rows facing south. One major exception is the Spanish Mission at bottom.

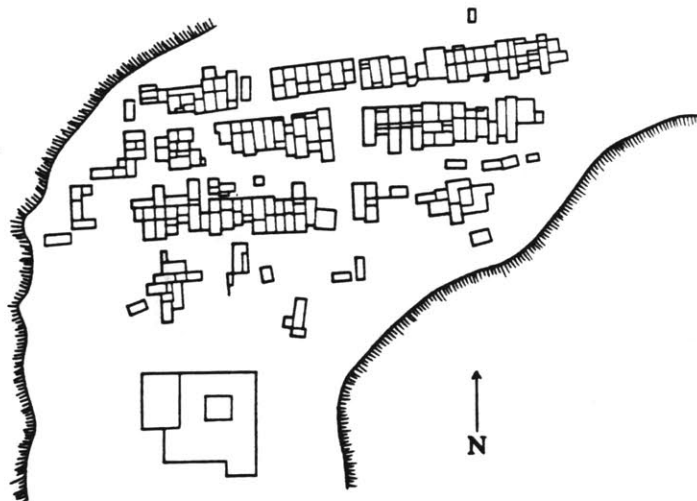

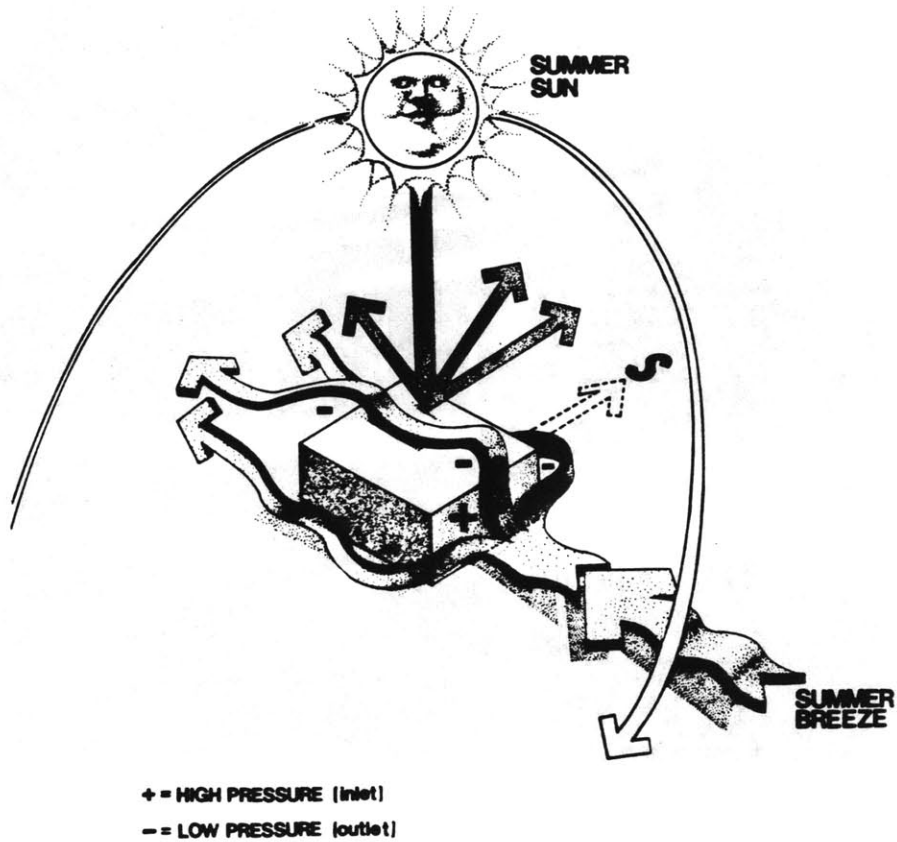

In order to take advantage of summer breezes for the ventilation of interiors: small openings must be placed to the windward side of a building and larger openings to the lee in order to pull air through. The key is to maximize air flow near the body in addition to ventilating the space.

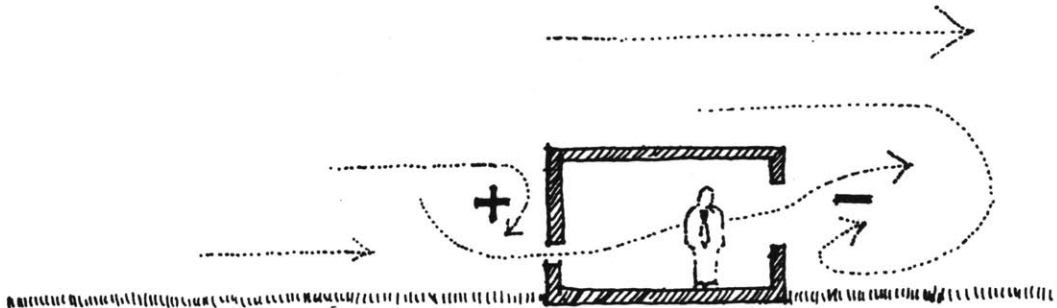

It is always tempting to tilt glass to be perpendicular to the winter sun, but:

Windows should be kept vertical, both to keep out the rain and to make them easier to keep clean. Solar intake for vertical windows is almost as great as the intake for apertures tilted at the optimum angle, since average ground reflectances of 20-30% nearly replace the energy lost by moving the glazing off the optimum angle. Perhaps the most important reason for keeping the windows vertical is that summertime shading is easier....²⁶

Primary collectors (windows) should be oriented due south when possible. However, "a 22° variation from due south lowers the seasonal intake by about 3%."²⁷

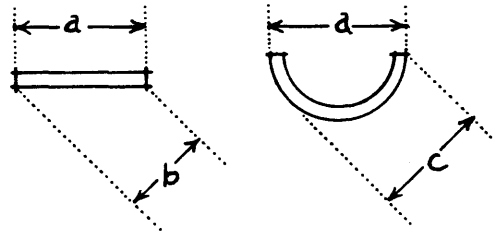

"A curved wall will intercept more energy, but only marginally more, for the aperture is enlarged only during the early morning [and late afternoon] hours."²⁸

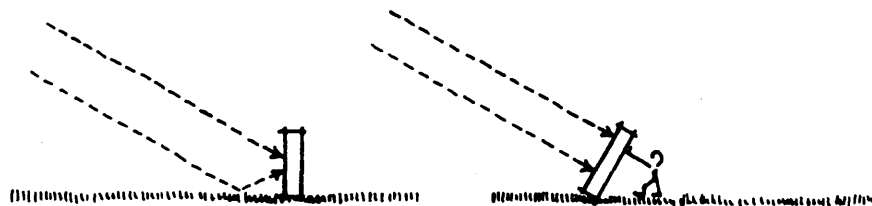

"Vertical walls receive more ground reflected energy than tilted walls, but tilted walls receive more direct and diffuse energy from the sky vault. The two effects combine so that a vertical wall receives only 15% less energy than a wall tilted at the optimal angle."²⁹

SOLAR SECTIONS - SYSTEMS

Preliminary design work for most energy-efficient structures begins with a serious look at the usual solar sections in order to choose a particular collection-storage-distribution system. Three categories of basic systems present themselves:

direct gain

indirect gain

isolated gain.

Combinations of these are often called "hybrid" systems.

DIRECT GAIN

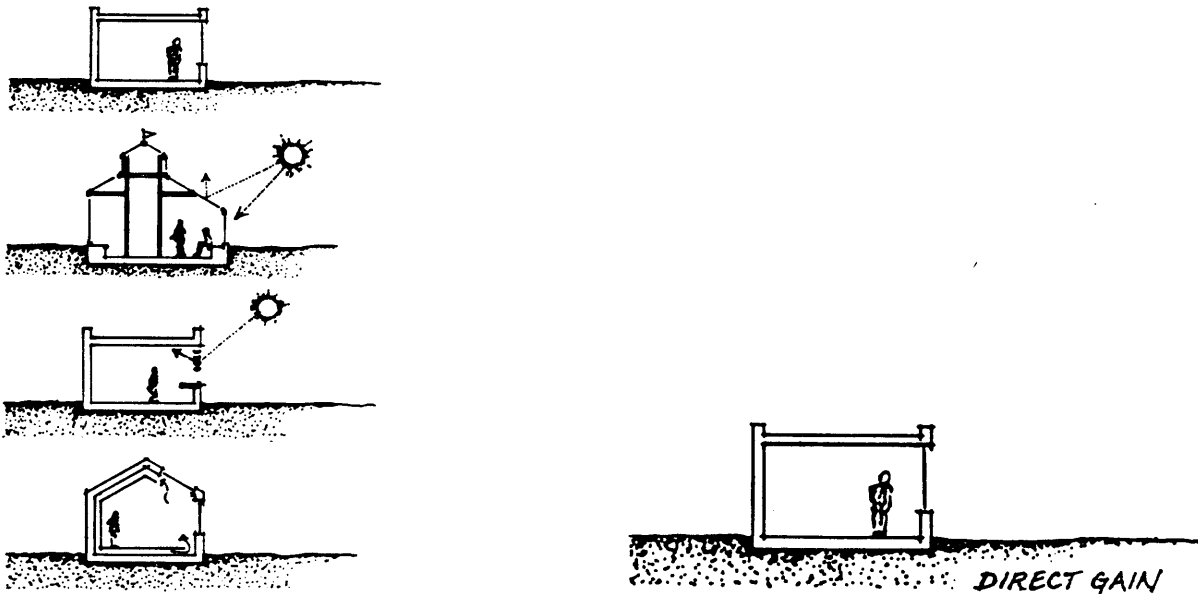

The building itself is the system. The glass is the collection area; the storage is the building's material; the distribution is by radiation. Excellent choice for cold, sunny climates. The glass area is roughly 20-25% of the floor area for a single-family, detached dwelling, while less collection area is required for office use due to higher internal gains.

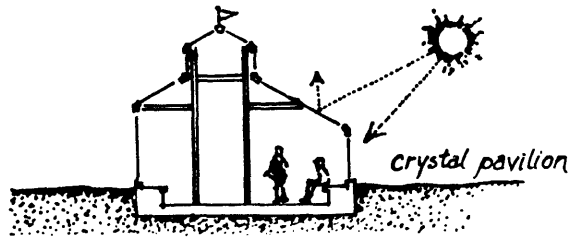

This system is for cloudy, moderate climates where the average outdoor temperature is 40°F. Diffuse light from all directions heats the space by entering through insulating glass such as the argon-filled heat-mirror glazing (R-5) used in the M.I.T. Crystal Pavilion.

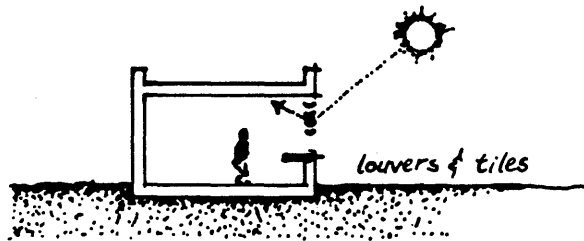

The reflective louvers in this "re-direct" gain system send beam radiation into dark-colored ceiling tiles containing eutectic salts (phase-change). Salt tiles on the window sill also store heat at an even temperature, greatly reducing the possibility of overheating.

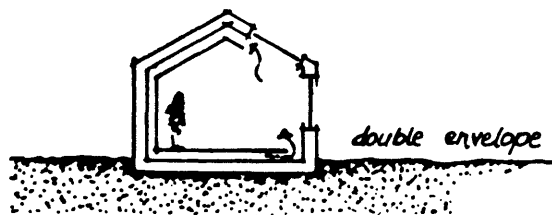

The double envelope system is a structure within a structure. Direct gain plus a fan-assisted air loop that circulates warmed air through a cavity. All the surfaces become fully charged with radiant heat. Mildew build-up within the walls is a potential problem. Using large ducts instead of entire wall cavities is also effective. The wall cavity approach has been outlawed in Europe by fire codes.

INDIRECT GAIN

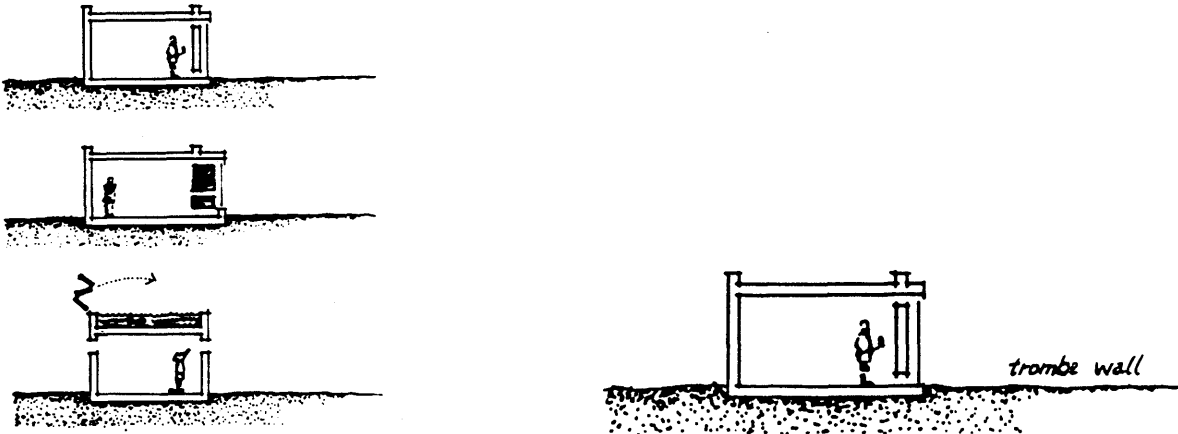

With indirect gain, the building itself is not the system. Glass is the collection area, but view is limited; the storage is at the wall plane; distribution is by conduction through the wall followed by radiation into the space, and by convection during daylight hours.

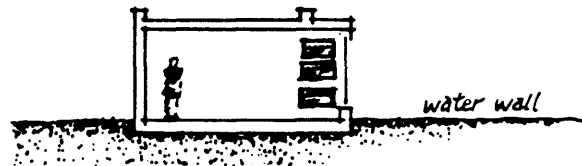

"Canned heat" system of water storage in containers: one-fourth less volume of water is needed to do the same job as masonry. Organic growth and leakage are potential problems.

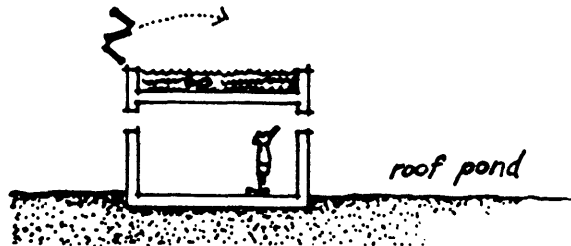

Like the eutectic salt tiles/reflective louvers, this is a radiant ceiling system. Complete freedom of interior space arrangement is possible while hiding under this waterbed. Effective for summer cooling when insulation is in place during the day and removal at night.

ISOLATED GAIN

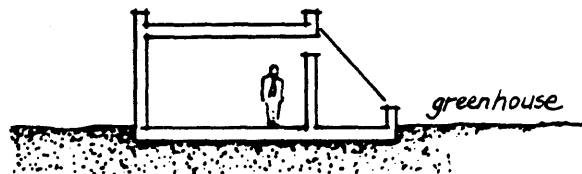
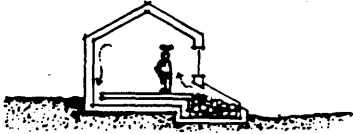
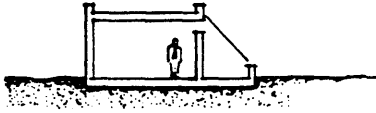

The attached greenhouse is an appendaged active heating zone that can be inhabited or not at the user's discretion. High temperature swings are likely while this zone heats itself and a portion of the adjoining space.

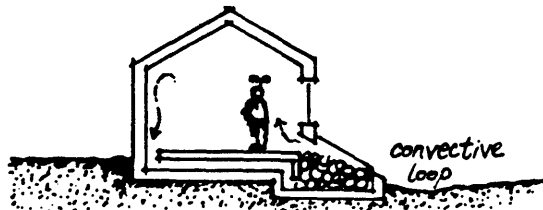

The convective loop rock storage system contains its storage outside and below the living space while heated air is circulated throughout.

HYBRID SYSTEM

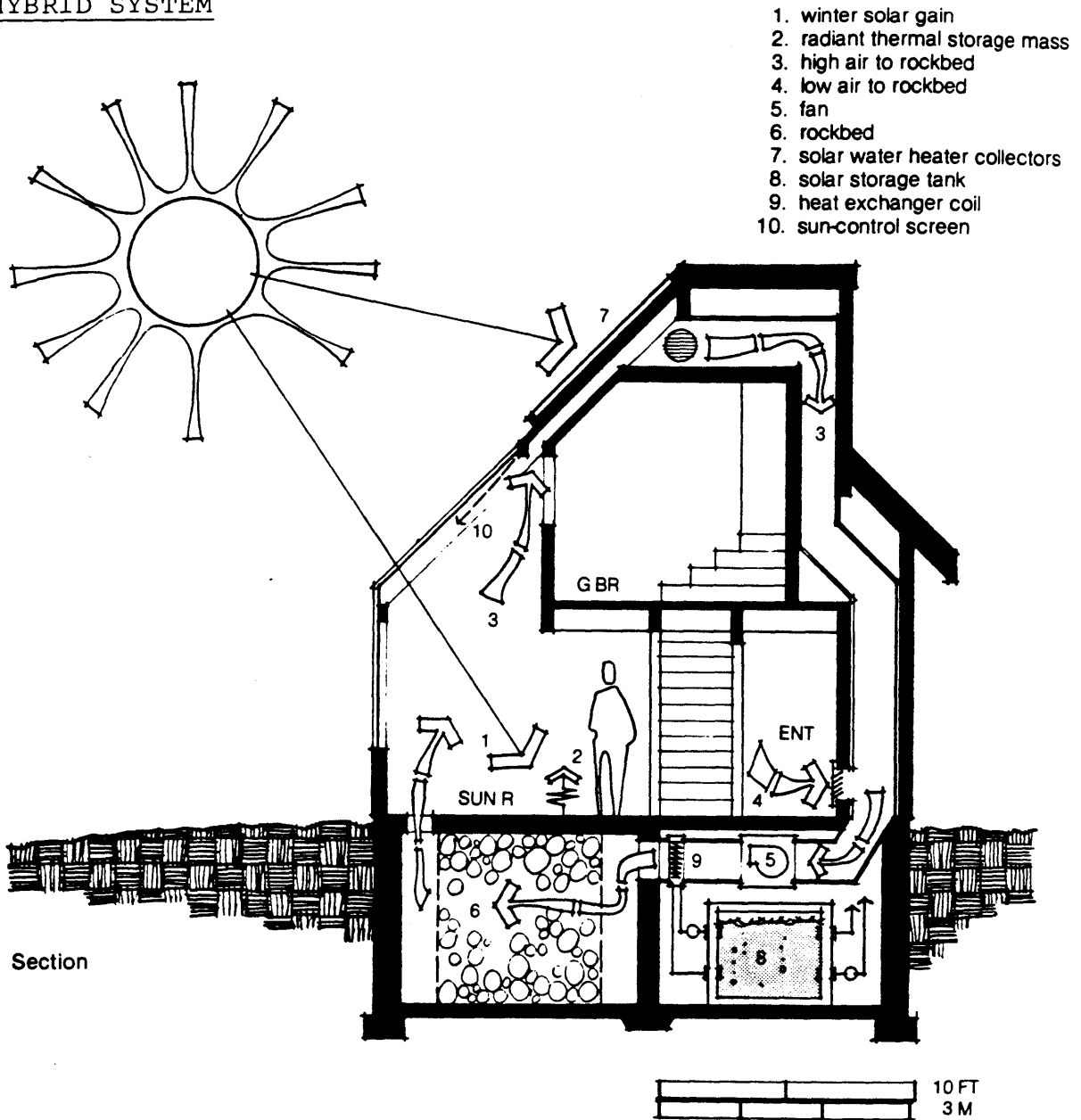

Section

When two or more systems are combined, a hybrid is born. Hybrids often include the use of fans or pumps to help the movement of air or fluid. This addition takes the system out of the "purist" passive category and nudges it towards the active (traitor!) systems. Certain advantages are incurred during this transformation which include: balanced heat distribution, system automation, effective movement of heat to mass, increased opportunity for integrating passive solar and auxiliary systems.³⁰

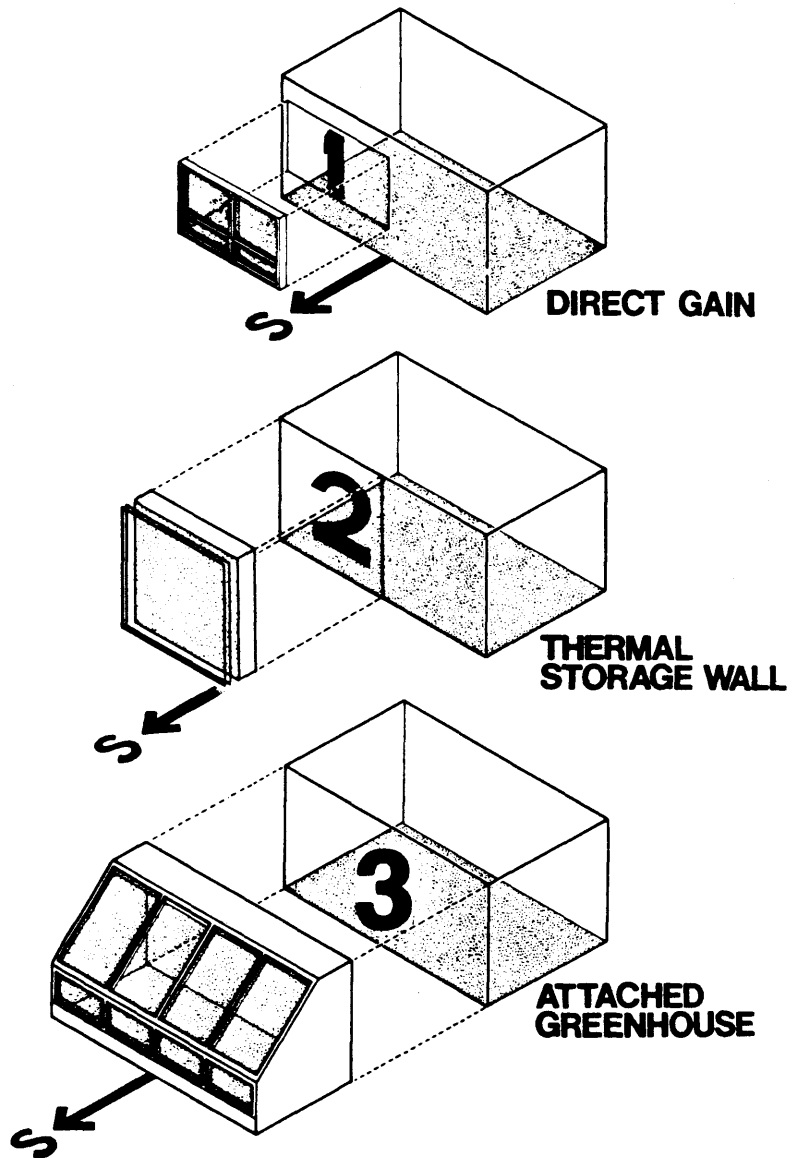

Mazria has made a comparison of 3 particular passive systems to see how much of each would be needed to heat an identical volume of space. This comparison could be used as a guideline when systems are combined, and as a graphic tool for demonstrating the relative efficiency of different systems based on a glass to mass ratio. A direct gain system is the clear winner.

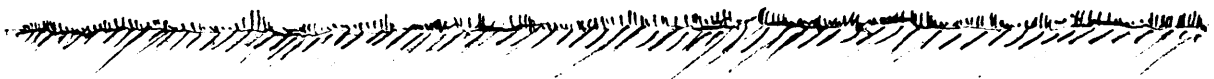
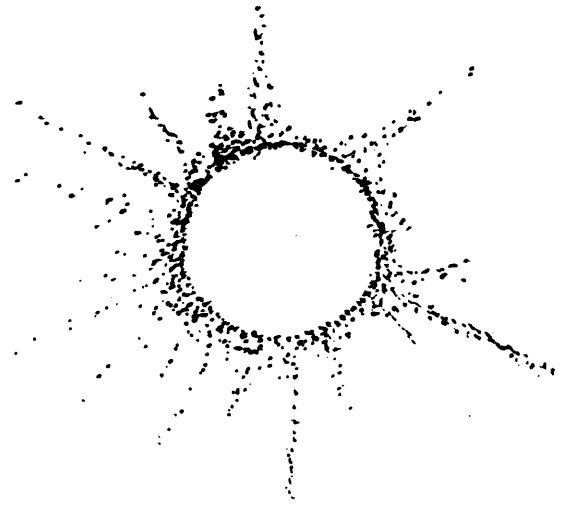

The goal in this observation of solar sections/systems has not been to find the optimal section for a particular building. All too often, the final result in the design of energy-efficient structures has taken that course: pick a section that looks good; extrude it to the length that you need; cut it off; plug up the end and call it a building. That approach gives us seriously maligned structures that may optimize energy needs while ignoring the needs of the inhabitants. We must broaden our scope and learn other aspects of LIGHT-FORM in order to avoid a singular approach to the design of our built world.

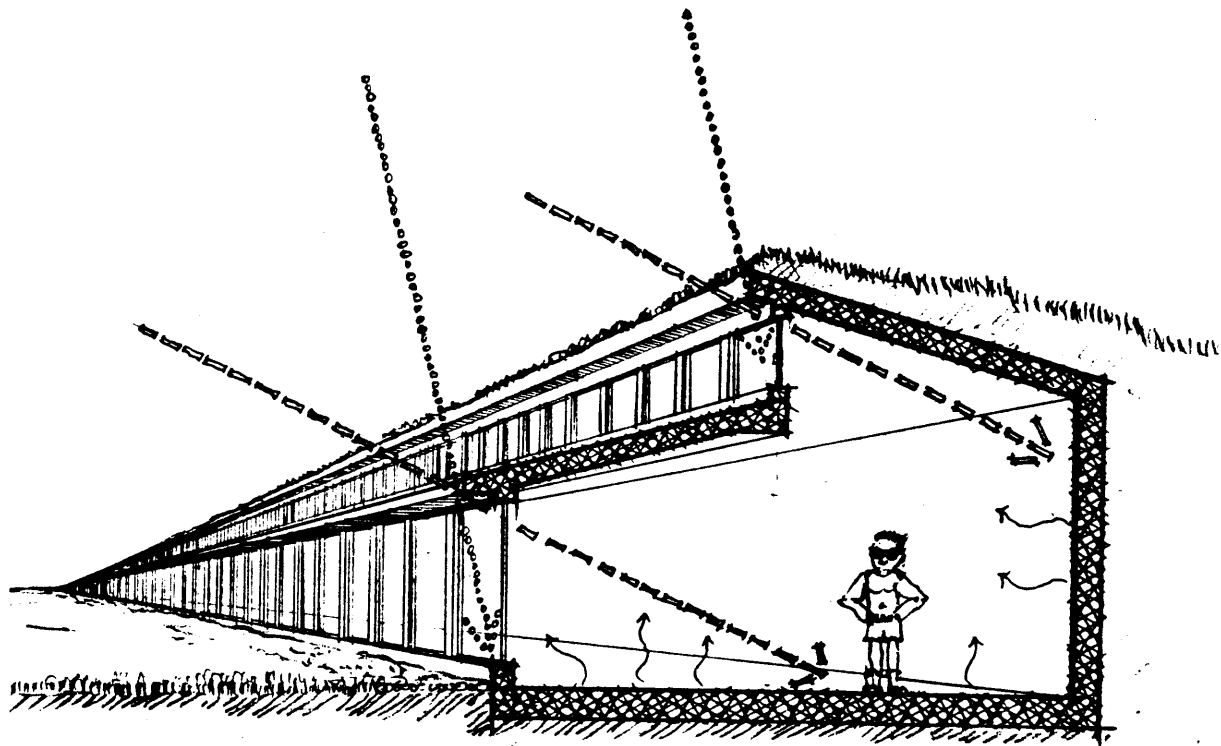

CLOSE OUT SPECIAL !!
 BUY 100 FEET OF SOLAR SECTION PG 24;
 GET 50 FEET OF NIGHT-TIME INSULATION FREE !!

CAT. NO: P.G. 24

available in 4' increments;
 minimum order 12'.
 (earth berm not included)

3. A RANGE OF FORMAL RESPONSES

a survey of references. . .

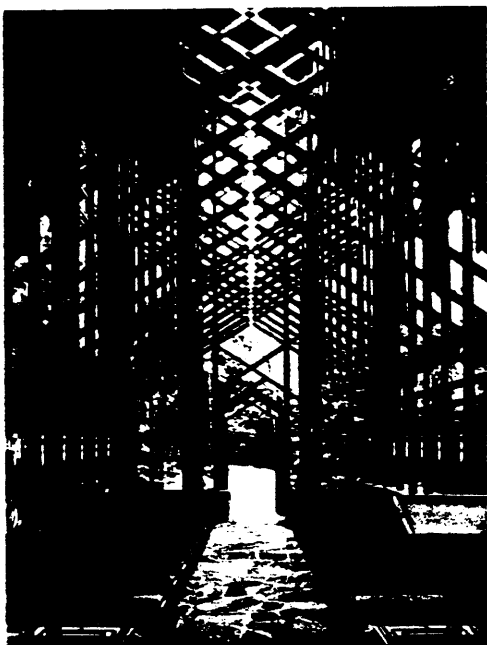

3.1 From Cave to Pavilion

3.2 Zonal-Territorial Responses to Climate-Light

3.3 Formal Responses to Wind-Climate

3.4 Collective Form: Additions of Systems

A survey of references...

A gathering of form...

A collection of building vocabulary that intends to encourage
the study of references in terms of light-form...

There is no search for the "answer" in this quest, but
rather the development of a more generic understanding of
form.

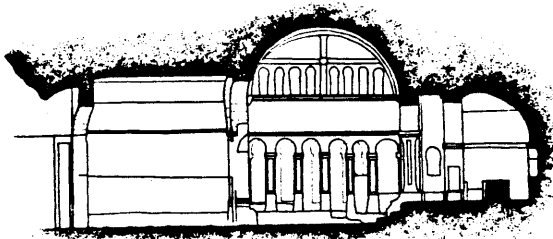

A-A

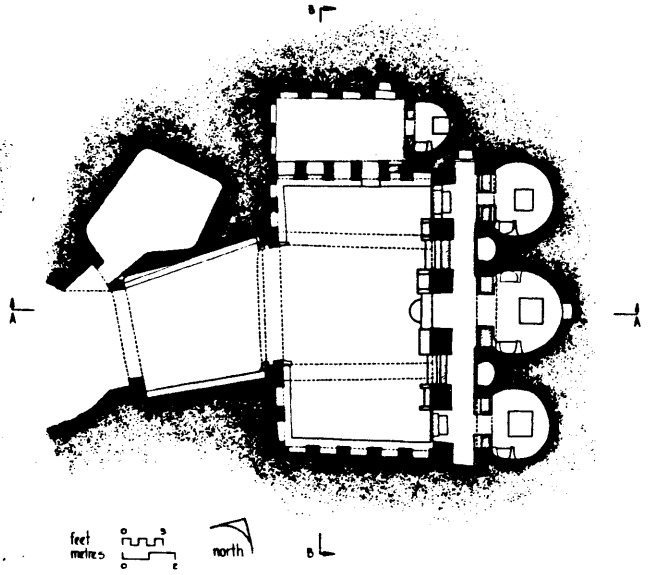

feet
metres



north

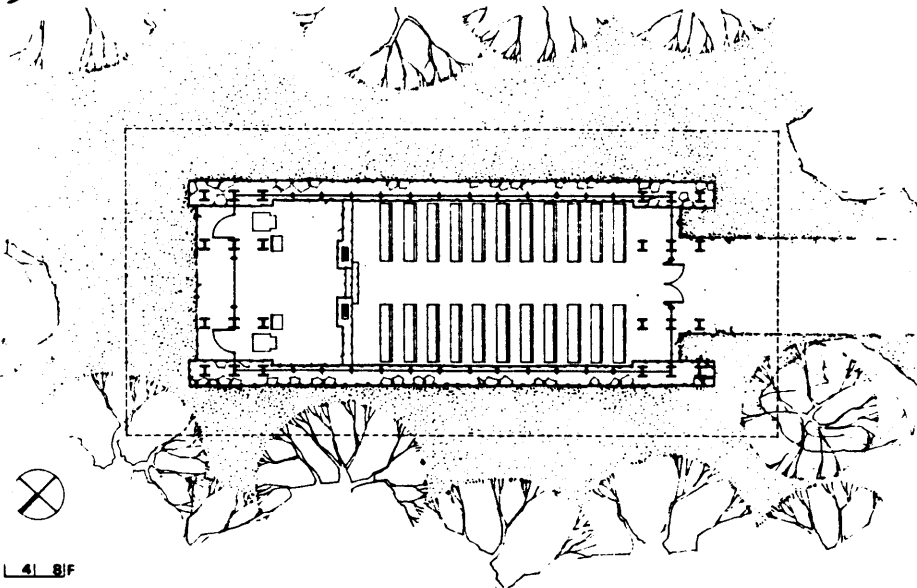
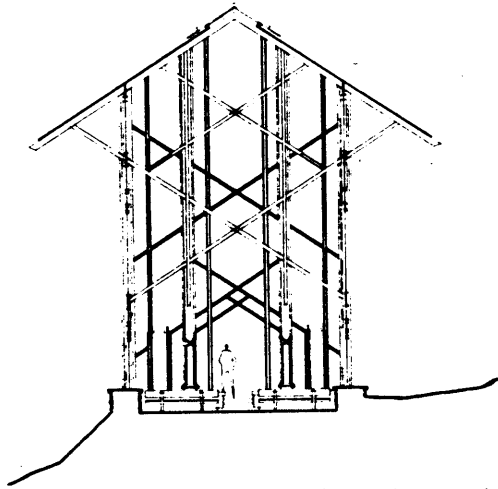

41 81F

3.1 From Cave to Pavilion

The built world exhibits a range of formal responses to light:

from cave to pavilion
 closed to open
 surface to frame
 dark to light
 etc.

From an energy standpoint, both ends of the range exhibit particular advantages and disadvantages. It cannot easily be said that one is more successful than the other in terms of its thermal characteristics. Most likely, a mix of both would be optimal.

The pavilion-like system admits generous amounts of light while the cave-like system serves to absorb the incoming light-heat. In general, the following characteristics of each can be listed:

- CAVE: advantages - high thermal inertia; stable temperatures.
- disadvantages - low light levels; cold and damp.
- PAVILION: advantages - easily warmed by the sun; high light levels.
- disadvantages - wide temperature swings:
 drastic heat loss in winter;
 high temperatures in summer.

Some aspects of the formal range of response are shown diagrammatically in the table on the following pages. The method of description compares traditional responses to their current translation with a brief description of the energy characteristics of each.

TRADITIONAL RESPONSE

CURRENT TRANSLATION

REMARKS

- a. FORM NOTES
b. ENERGY ELEMENTS



- a. CAVE-LIKE RESPONSE;
FULLY CONTAINED;
DEFENSIVE; INHABITING
THE GROUND.
b. HIGH MASS BUFFERING;
INTERNAL GAINS MAIN
HEAT SOURCE;
LOW SA:V RATIO.

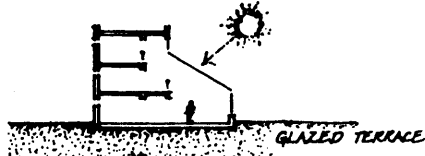
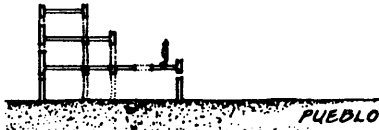
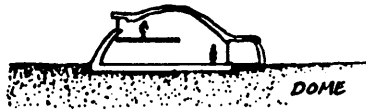
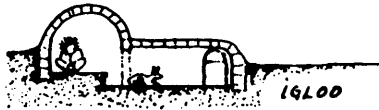

- a. THE CAVE STEPS UP TO
RECEIVE MORE LIGHT;
STILL DEFENSIVE, BUT
ALSO CONTAINING SOME
LIGHT.
b. EXPOSES MORE SURFACE
TO THE LIGHT.

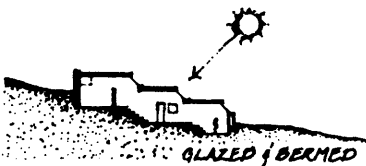
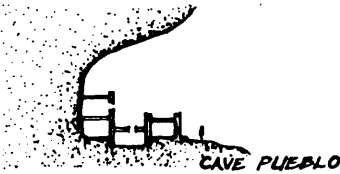

- a. INHABITING THE GROUND
WITH THE TERRACE.
b. EARTH SERVES AS SOLAR
RADIATION TRAP.

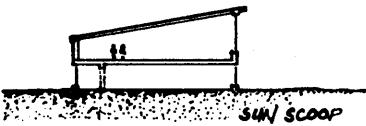
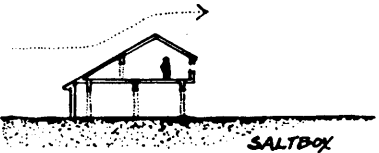

- a. THE CAVE SHAPE IN SPACE
IS BUILT IN SOLID; FORM
RESPONDS TO SUN-WIND.
b. INCREASED VERT. SURFACE
TO SOUTH; DECREASED
VERT. SURFACE TO NORTH.

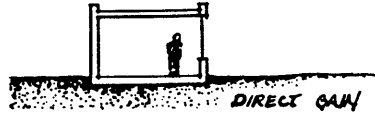
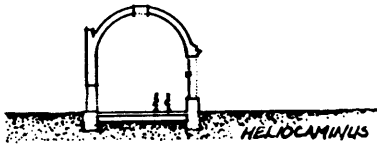

- a. THE CAVE-LIKE RESPONSE YAWNS TO THE SOUTH.
- b. GENERIC SOLAR DIAGRAM; INT. SURFACES RADIANT HEAT SOURCE.

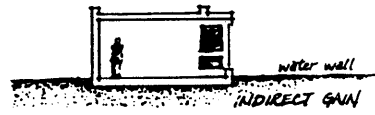

- b. "CANNED HEAT"--CONCENTRATED HEAT ZONE AT THE EDGE OF THE BLDG.

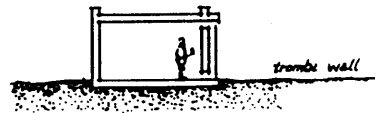

- b. "SANDWICHED" HEAT ZONE.

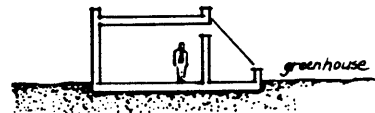

- b. "APPENDAGED" HEAT.

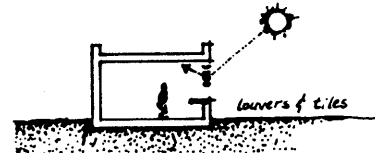

- b. REFLECTED LIGHT-HEAT TO DARK-COLORED CEILING TILES W/ EUTECTIC SALTS.

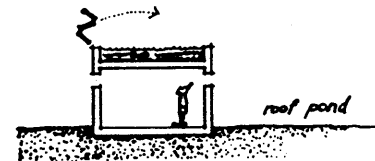

- a. PROPPING UP THE OCEAN & INHABITING THE SEA FLOOR.
- b. CANNED HEAT-HIDING UNDER THE WATER BED.

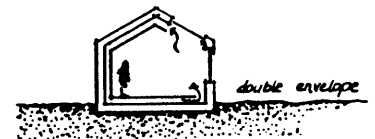

- a. A HOUSE WITHIN A HOUSE; PACKED VERSION OF THE CAVE PUEBLO.
- b. SPACE ITSELF IS THE HEAT ZONE; SURFACES ARE A RADIANT HEAT SOURCE.

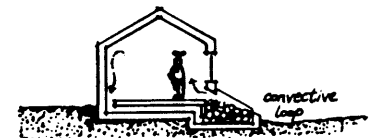

- b. CULTIVATING THE TALUS FIELD.
- d. CANNED HEAT PLUS CONVECTION OF AIR.

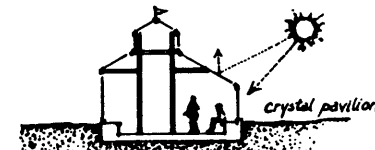
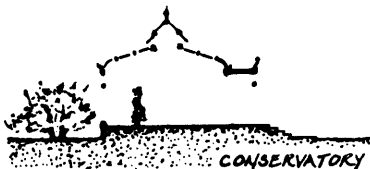

- a. COMPLETELY TRANSPARENT; LETTING THE SUN SHINE IN.
- b. DIFFUSE RADIATION & DIRECT BEAM CAN HEAT-OVERHEAT THIS PAVILION.

There is an apparent leap from the heliocaminus (Roman sun trap) to the conservatory (English greenhouse) in the realm of traditional responses.

Between these two responses there are few traditional examples that exhibit any real formal difference other than simple variations of the amount of glass and mass that they might contain.

Within this range lies all the usual solar diagrams.

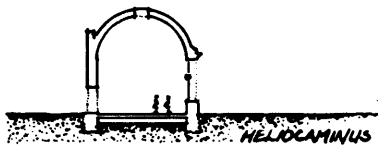

The heliocaminus is very similar in form to the majority of solar diagrams that have been generated in recent years. It is a cave-like response with a large opening facing south to admit light-heat.

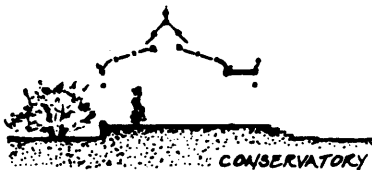

The conservatory is a completely transparent pavilion that admits light-heat from all directions. It is very similar in form to the most recent solar diagram made possible by the advent of new glass (heat-mirror) that is more resistant to thermal losses.

These diagrams have emerged recently as a technological response to dwindling (and politically volatile) fossil fuel supplies. They indicate the general direction of energy-specific formal responses to light.

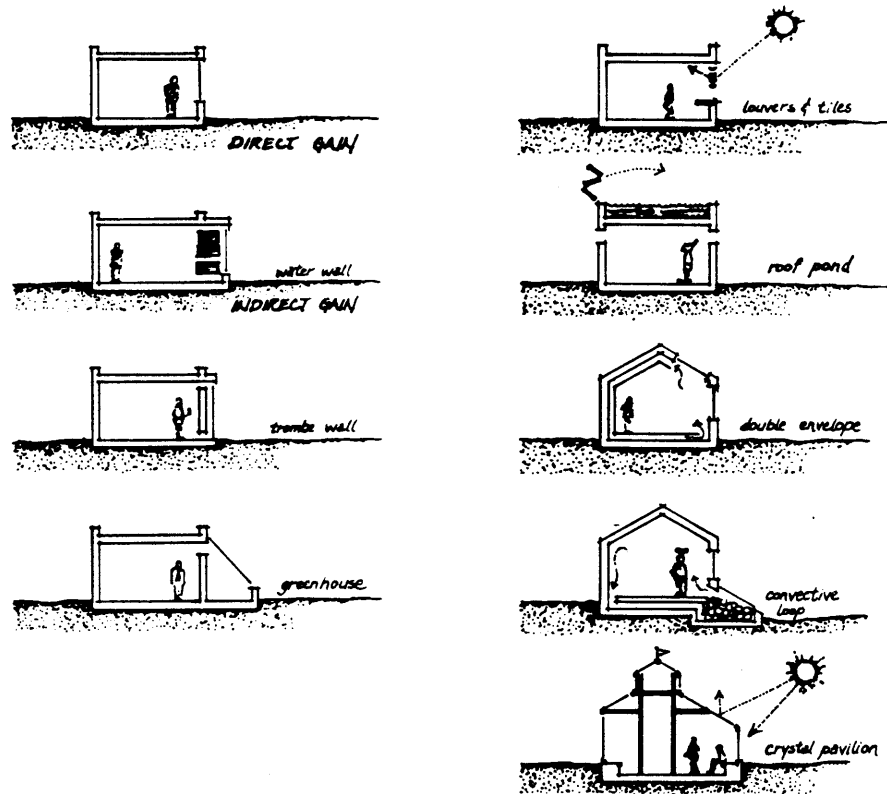

In a later section of this thesis--the Design Vocabulary portion--the thermal characteristics in four of these diagrams (direct gain, trombe wall, greenhouse, and double envelope) will be utilized in principle while exploring the possibility of making the storage system part of the inhabited space rather than just a technological addition to a wall.

Another aspect of the Design Vocabulary section and the Associative Form section will be how two systems, like the two ends of the formal range, can work together.

3.2 Zonal-Territorial Responses to Climate-Light

How does a building's organization respond to its climate, if at all?

The most recent response: shrink-wrapped facades,
skin-tight membranes keeping the
outside out and the inside in.

The less recent response: physical definition of zones
territories ...
which build varying climates in
and around.



*TERRITORIAL OVERHANG
A.K.A.
COVERED PORCH.*

A building's organization can respond directly to a local climate by establishing zones-territories that build a range from the tempered interior to the outdoors. The following references demonstrate this principle in climates ranging from the arctic to the equator.

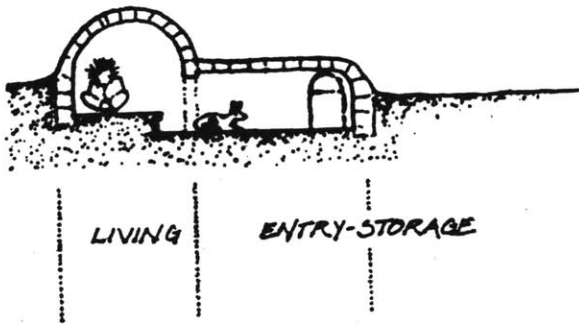

The entry-storage zone of the traditional igloo serves as a dimensional buffer between the outside and the inside. Within this zone, storage of tools and miscellanies along with work dogs provides an effective insulating and heat-generating area to ease the transition to the severe climate outside. The entry is shielded from the wind and the ceiling height is kept to a minimum in order to reduce the volume of tempered interior space. The floor level of the living zone is higher, thus encouraging cooler air to settle in the entry-storage zone.



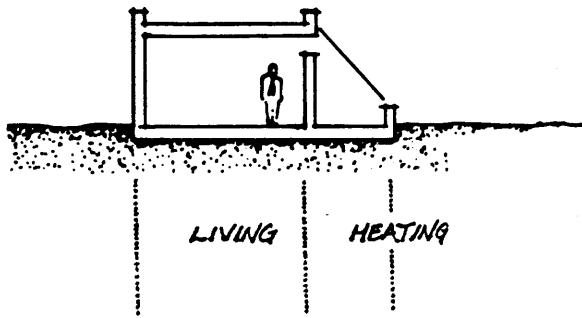

The attached greenhouse is a solar diagram that takes a territorial approach to heat collection. The greenhouse is a thermal zone that can accept large quantities of light-heat. The space usually experiences large temperature swings. As the area gains heat during sunny daytime hours, the warmed air rises and finds its way into the adjoining living zone. Heat also conducts through the massive wall that separates the two zones. The greenhouse can be inhabited optionally at the user's discretion.

1. indirect winter solar gain
2. radiant heat from greenhouse thermal storage
3. warm air from greenhouse
4. return air to greenhouse
5. duct to bedroom zone
6. direct winter solar gain
7. solar water heater collectors

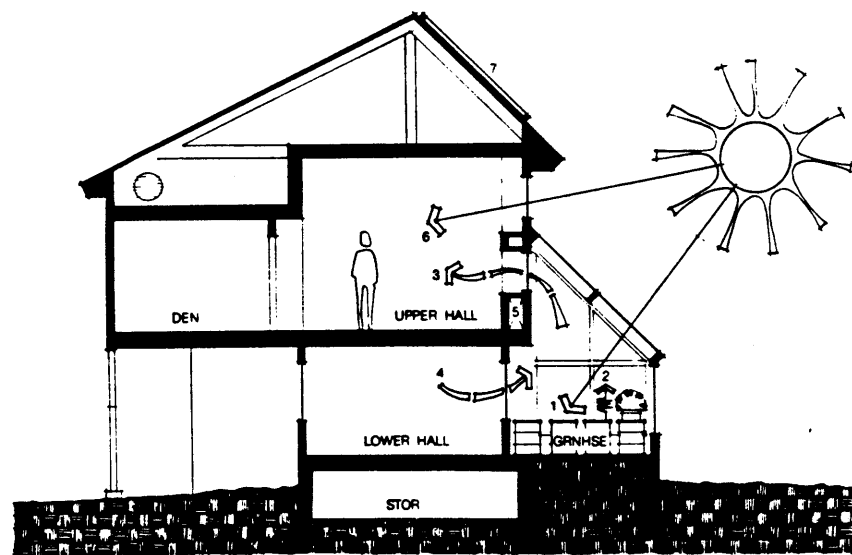

Section through greenhouse

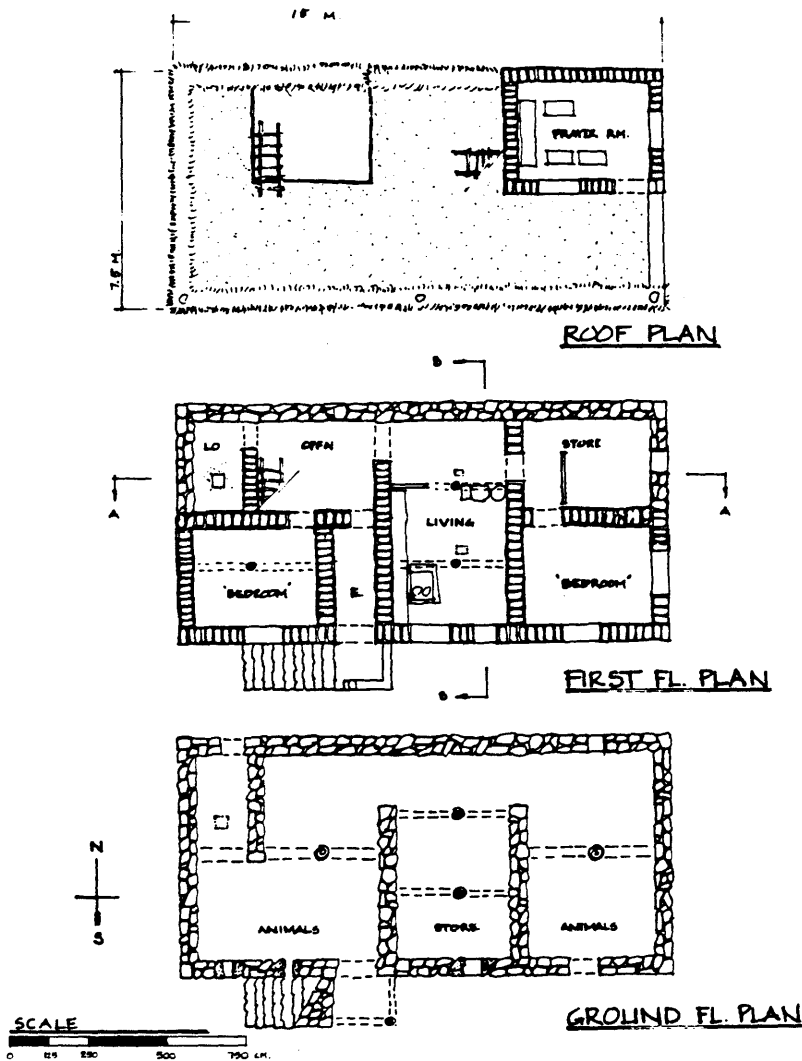

The Himalayan house shown incorporates three thermal zones in the vertical direction. The lower floor is reserved for animals (a heat source) and storage. The middle floor is the living quarters with bedrooms appropriately located above the animal stalls. The upper floor has two types of thermal barriers--one is a surface (sod roof) while the other is a habitable zone (prayer room). An open court in the living zone admits light to the north wall of the enclosed space. The combination of the prayer room in the upper zone and the open court in the middle zone starts to build an exchange between the outside-inside, open-closed, light-dark.

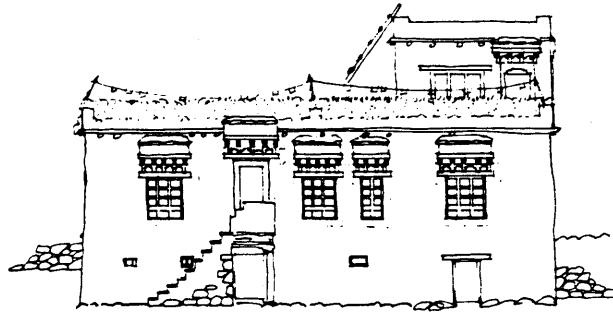

SOUTH ELEVATION

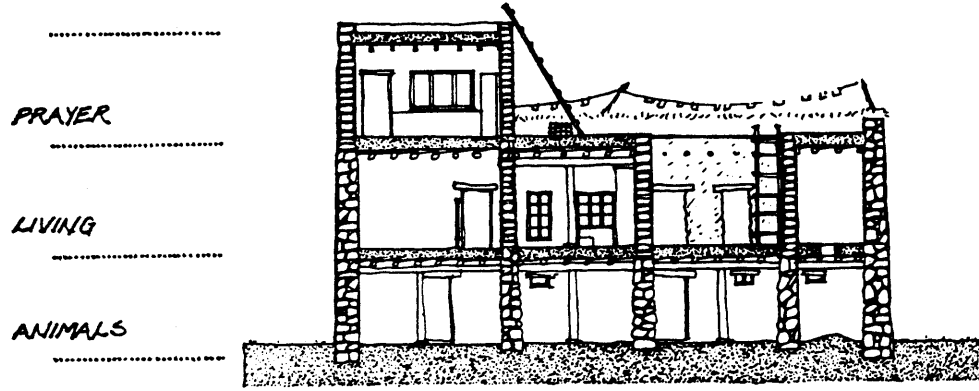

SECTION A-A

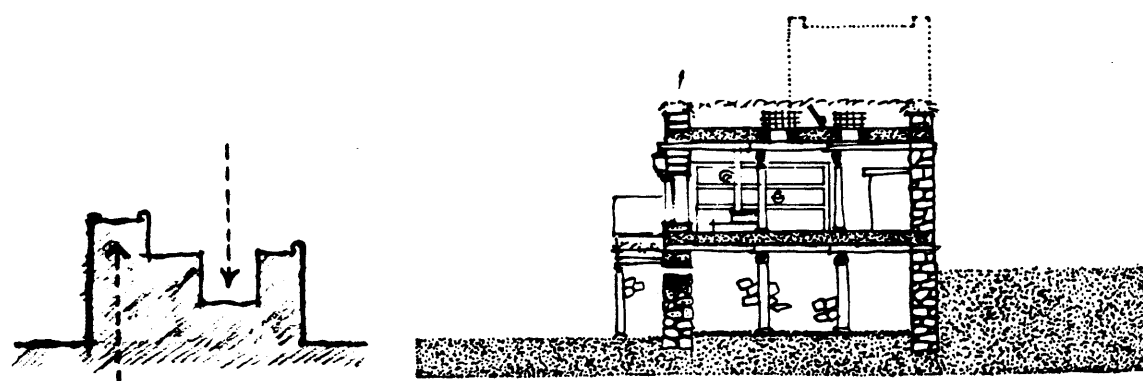

BUILDING AN
EX-
-CHANGE
BETWEEN ZONES.

SECTION D-D

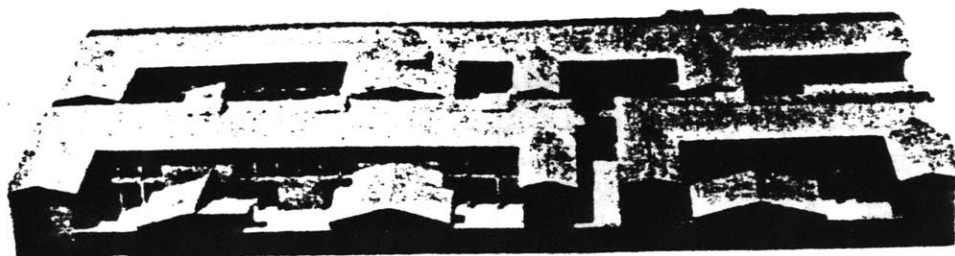

Above: Olynthian villa, scale model from the Royal Ontario Museum in Toronto. Overhangs commonly shaded the interior from the high summer sun.

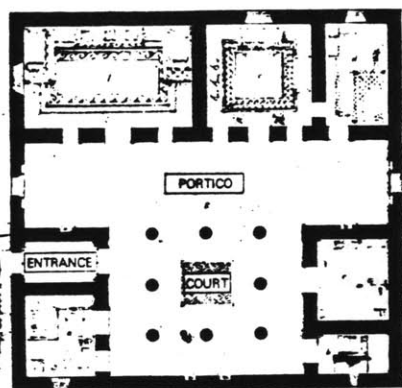

Floor plan of a house in Delos, from Exploration Archéologique de Delos. The main rooms at the back of this house, which closely resembled homes in the North Hill section of Olynthus, opened onto a covered porch and courtyard to the south (bottom of diagram).

Energy crises are not new among urban dwellers:

By the 5th c. B.C., many parts of Greece were almost completely denuded of trees....The use of solar energy to help heat homes was a positive response to the energy crisis.³¹

A typical urban dwelling in Greece was organized with a south-facing open court defined by adjacent masonry enclosures. The enclosures on the north side of the court often reached a two-story limit while the "wings" to the east and west were usually one story. This formal organization provided a tempered court in winter that both captured the sun and shielded the north wind. This combination improved microclimate conditions for both zones of the dwelling: outside-inside, open-closed, light-dark.

Right: Typical street plan in the North Hill section of Olynthus. This ancient community aligned its streets and avenues so that all buildings could face south.

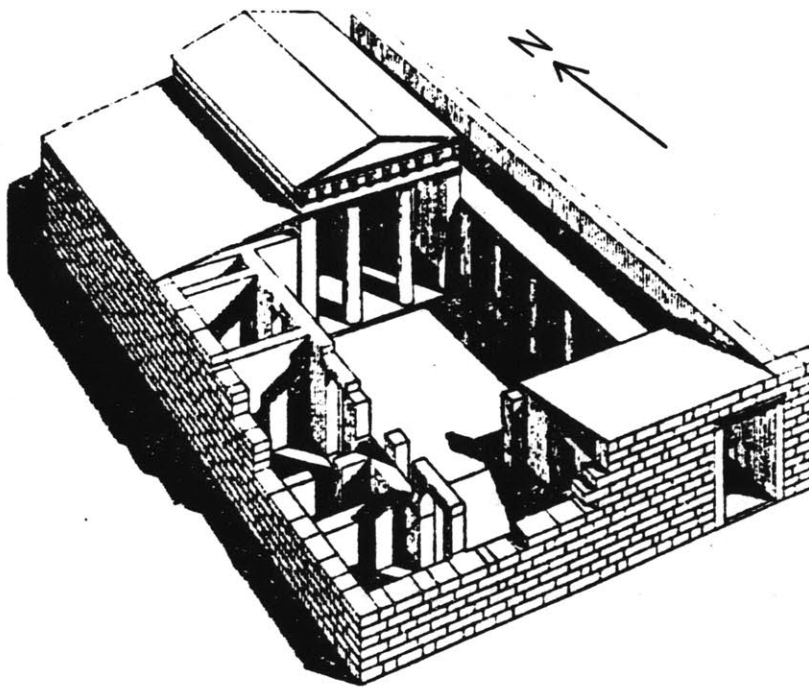
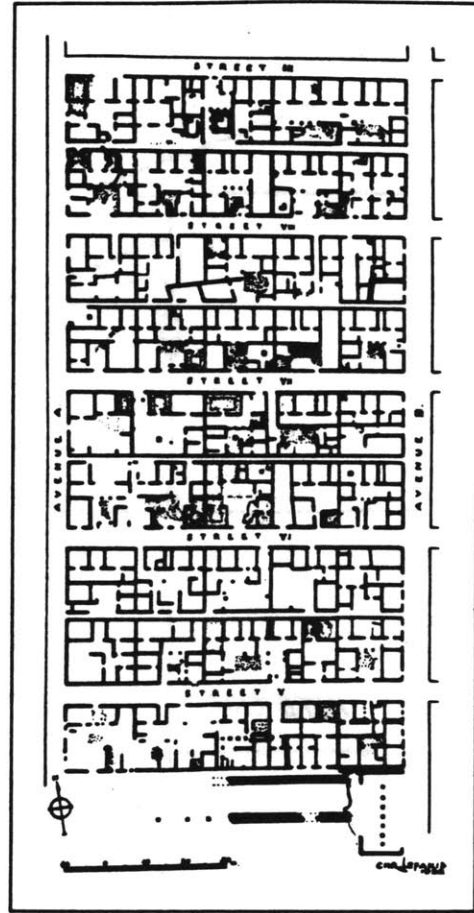

Reconstruction of a Classical Greek home, from excavations of the city of Priene by Theodore Wiegand. The rooms behind the portico faced south onto the courtyard.

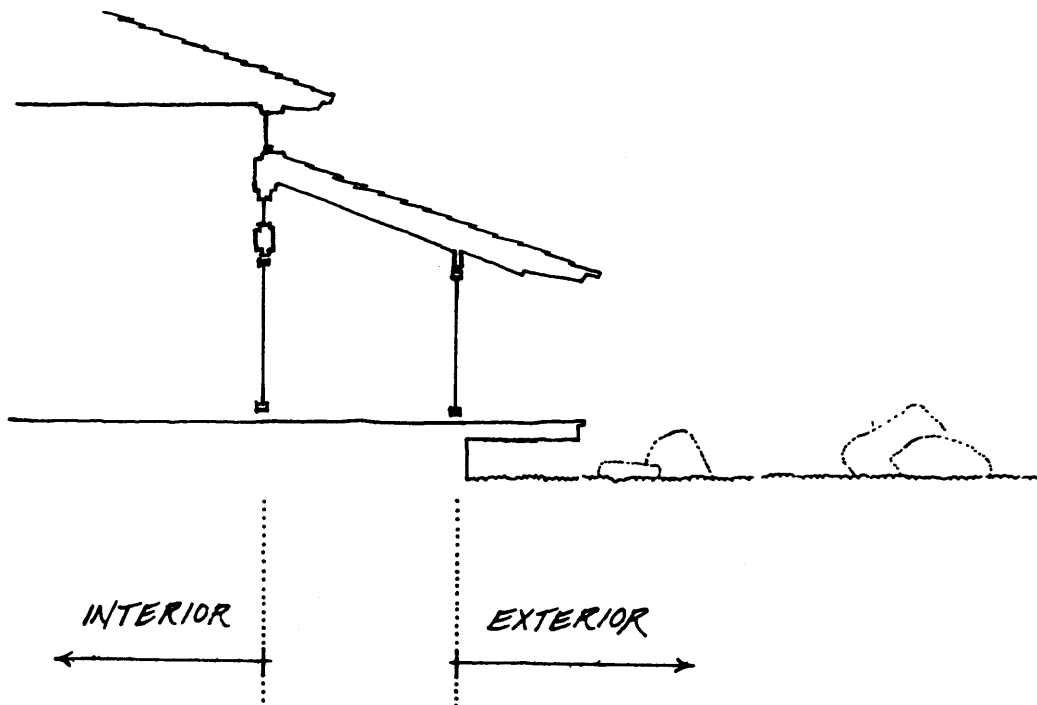

The Japanese have devised a formal organization that allows the interpenetration of several thermal zones:

- an interior living zone
- an "in-between"
- an exterior garden.

These are separated by sliding screens that can arrange the space-climate in a variety of ways.

Other means of zonal exchange incorporated by the Japanese include:

- hinged panels & shutters
 - allowing entire walls to be opened
- rolling screens
 - for spatial shading of verandas.



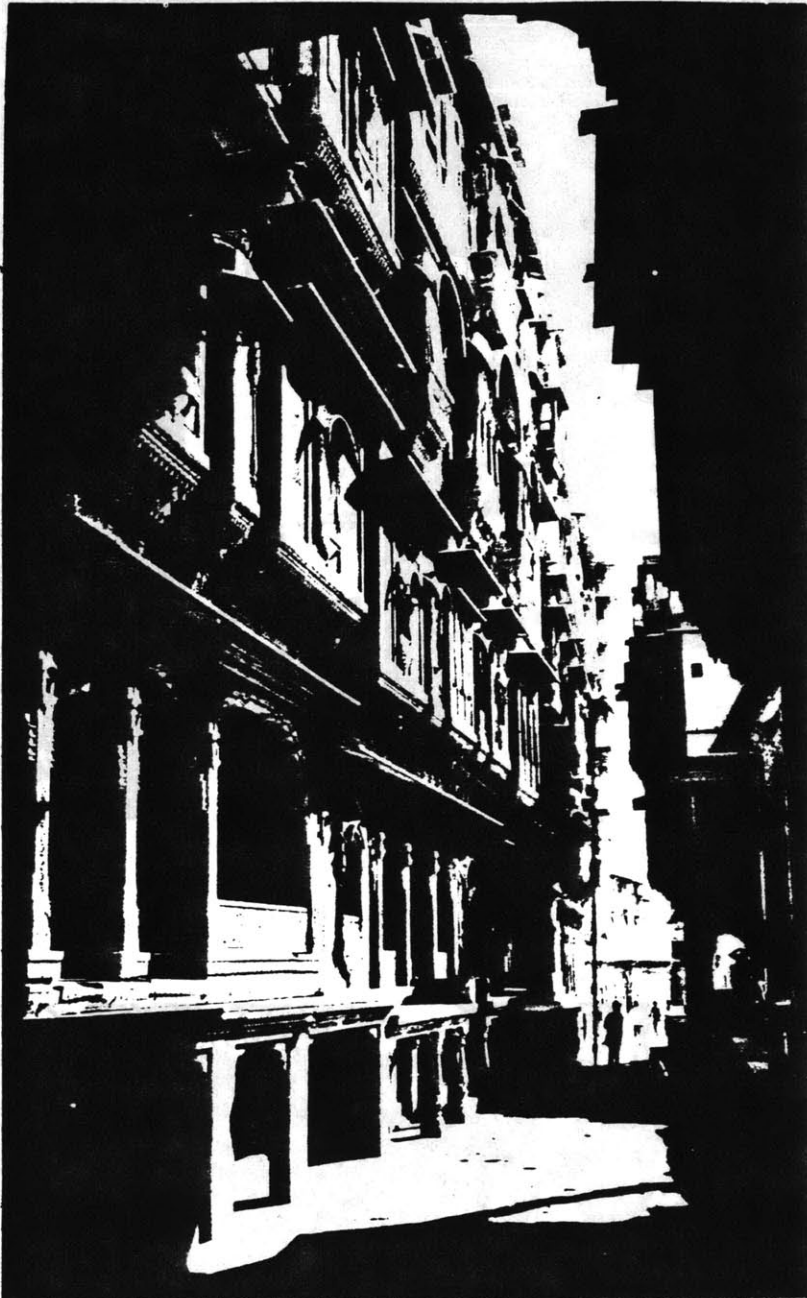

The final example of this section demonstrates a zonal response to a very hot climate--the opposite end of the range from the igloo's environment. While the igloo severely limits the surface area it exposes to the outside in order to reduce heat loss, the formal organization in the Indian fort town of Jaisalmer greatly increases its surface area to aid cooling.

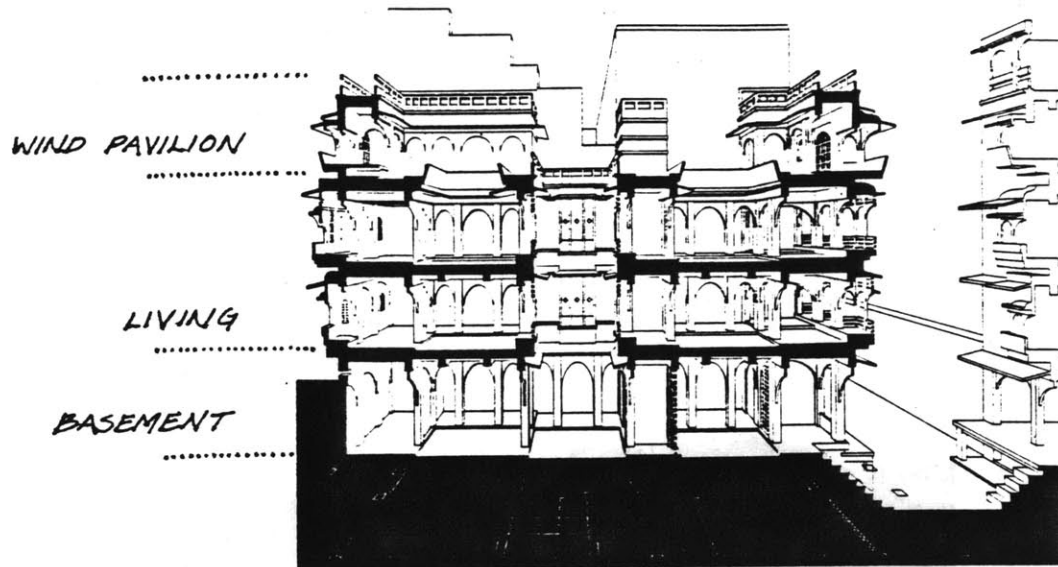

The wall zone in this example is composed of decorative jalis and balcony projections that extend out several feet beyond the perimeter beam. These extensions occur at each floor level, thus serving to shade the balcony below and to increase the exposed area of the perimeter's surface. Additional thin limestone overhangs also participate in making a well-shaded facade.

The building is zoned vertically as well. An upper "wind pavilion" provides a useful space for winter and evening use while also serving as a territorial double roof that helps reduce heat conduction to the zones below.³² The mid-section is the primary living space. The basement is used for sleeping when temperatures climb to their maximum of 122°F.



3.3 Formal Responses to Wind-Climate

Air movement is a direct response to sun action. Wind can be defined as thermally induced convection currents. Air moves from areas of high pressure toward areas of low pressure--across the planet and across the room. Buildings respond to the presence of wind within a range from protection to coercion, depending on the climate. In a cold climate, buildings will do their best to be protected from the wind; in a warm climate, buildings will channel breezes and accelerate ventilation.

To begin this portion of the survey of built responses to wind, it is useful to observe how the wind will shape a pile of loose sand.

The particles are sequentially



relocated by the air move-



ment until the pile



reaches a state of equilibrium.





Left: The Colonial "saltbox" house was well-suited to the harsh New England climate. Deciduous vines on the trellis, or "pergola," blocked the summer sun but shed their leaves in winter to permit sunlight to enter the south windows easily.

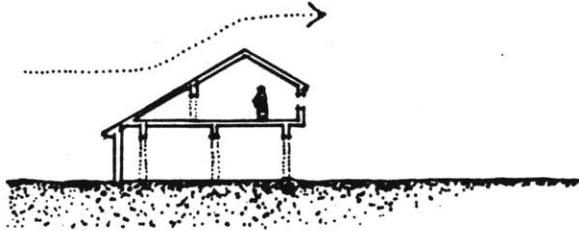

This same state of equilibrium can be seen in built form as well. The New England vernacular maintains a similar shape as the sandpile: a long, sloped roof rests atop a short north wall as if the dwelling had actually been shaped by the wind. Unfortunately, this formal response has been labeled as a "style" and been transplanted into a suburban context with little regard for its climatic origin and orientation.

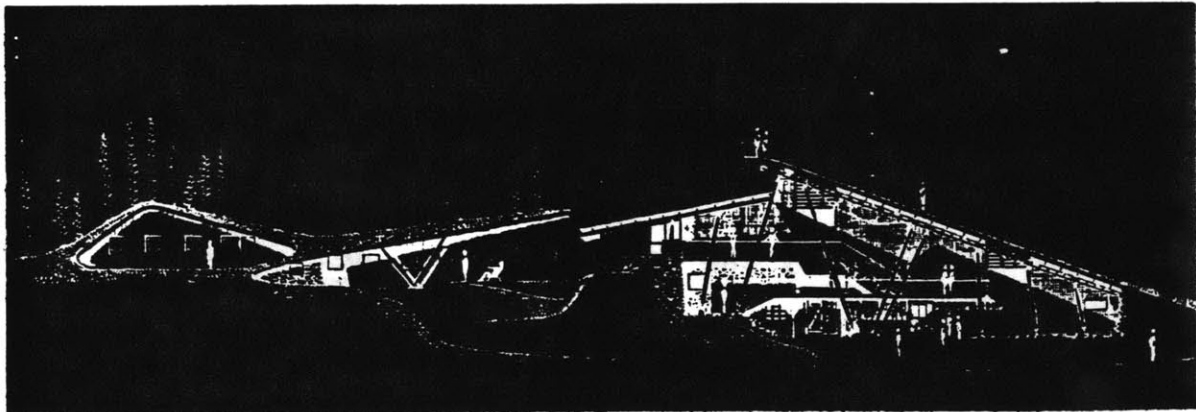

Ralph Erskine's ski resort hotel in Borgafjäll (1948-50) responds to the wind in a similar way as the New England saltbox. The sheltering effect here is achieved by transforming the surface of the earth. Redirecting the wind in this way provides a zone of protection that extends beyond the building itself and into the landscape.



In the Shimane Prefecture in western Japan, building compounds are organized in tight clusters shielded by tall evergreen hedges. The barriers provide a well-protected zone on their lee side.

In most warm climates, the wind is encouraged to flow through buildings. Air movement is enticed to ventilate an interior by intensifying the pressure difference between the inlet (+) and the outlet (-).

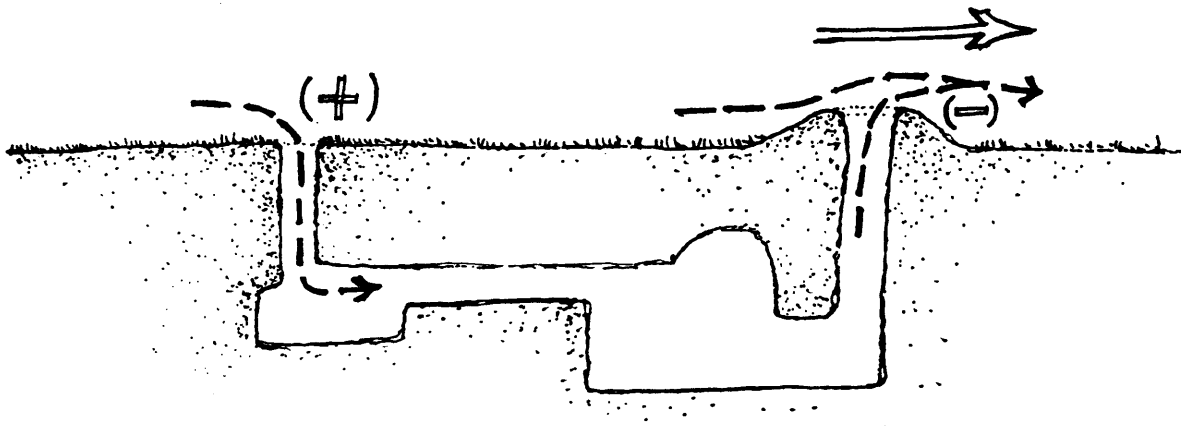

One method of inducing air flow is demonstrated by our spring forecaster--the ground hog. His/her tunnel system will normally have two means of egress (as required by code). One of the openings will be flush with the ground surface while the other will be mounded at the perimeter. In addition to denoting the difference between grand entry and back door, this serves to build a difference in pressure between the two openings. The mound causes the air moving across it to shear as it is redirected across the opening, thus creating a negative pressure in this area and allowing the resultant suction to pull air through the tunnel.³³

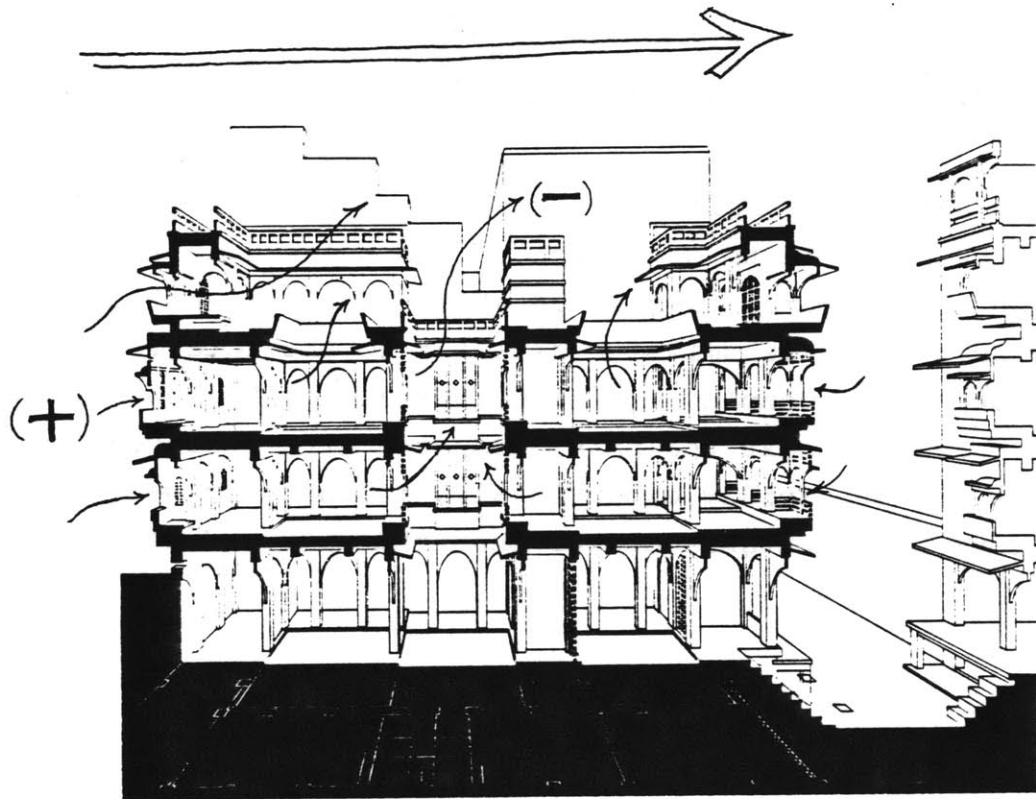

A more complex version of these same principles are at work in the limestone buildings of Jaisalmer, India. These structures are very porous with small openings to the street and large interior courts open to the sky. In general, the prevailing breezes run perpendicular to the streets and create similar pressure differences between the inlet (facade) and outlet (courts) as seen in the ground hog example.

Thermal differences between the sun-beaten roofs and the shaded facades also assist in the convective flow. Warm air rising in the upper zone is replaced by cooler air drawn from below. This movement will provide some ventilation of the interior spaces even when the prevailing winds have subsided.

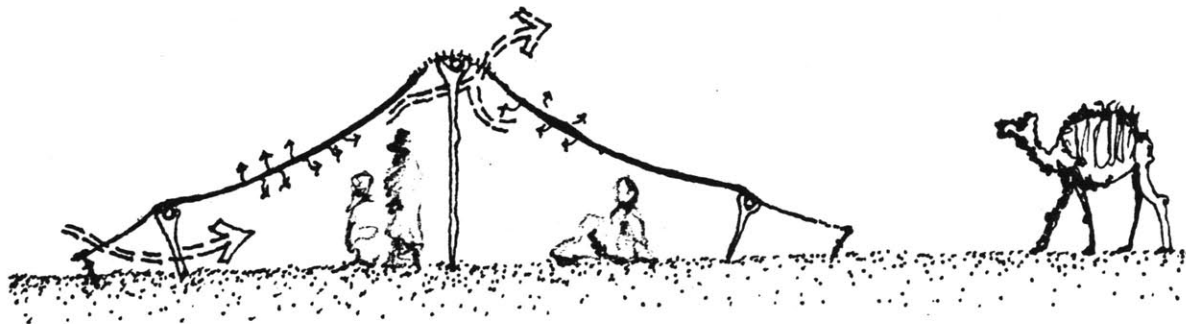

Another example of thermally induced ventilation occurs in the black tents of Morocco. The black material causes very high temperatures to develop at the surface while greatly reducing the transmission of light to the interior. The high temperatures coupled with openings along the low walls and screened vents at the peak produce a strong convective flow. This effect rapidly exhausts air, making this well-shaded environment measurably cooler than the surrounding desert.³⁴

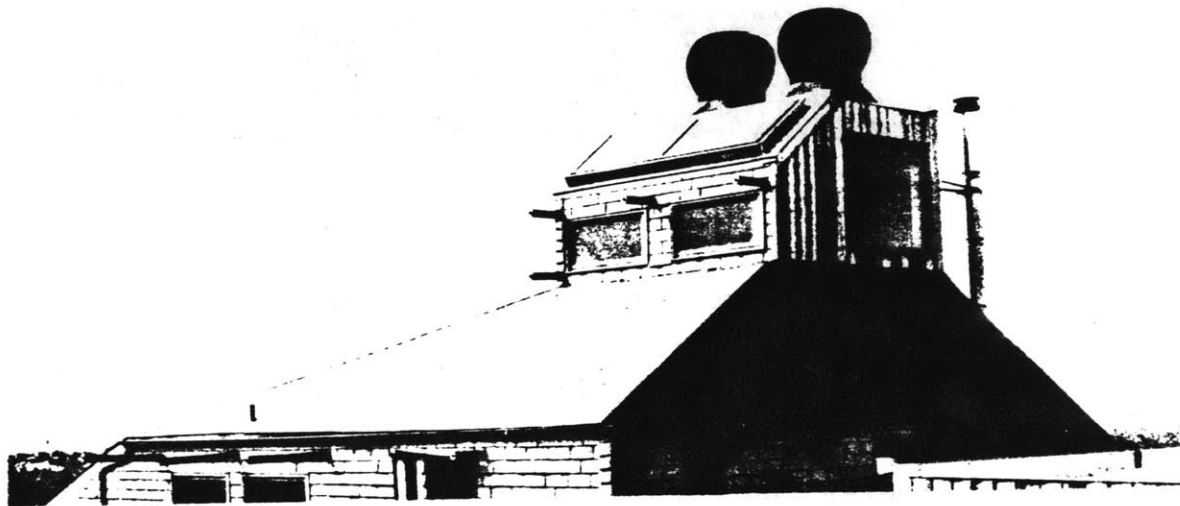

Agricultural buildings have used vented cupolas for generations. The recent solar movement has intensified this vernacular approach by glazing the shaft and calling it a thermal chimney. Like in the black tents, very high temperatures at the peak give a "pull start" to the convective flow. As the distance between inlet and outlet increases, the speed of air-flow increases.

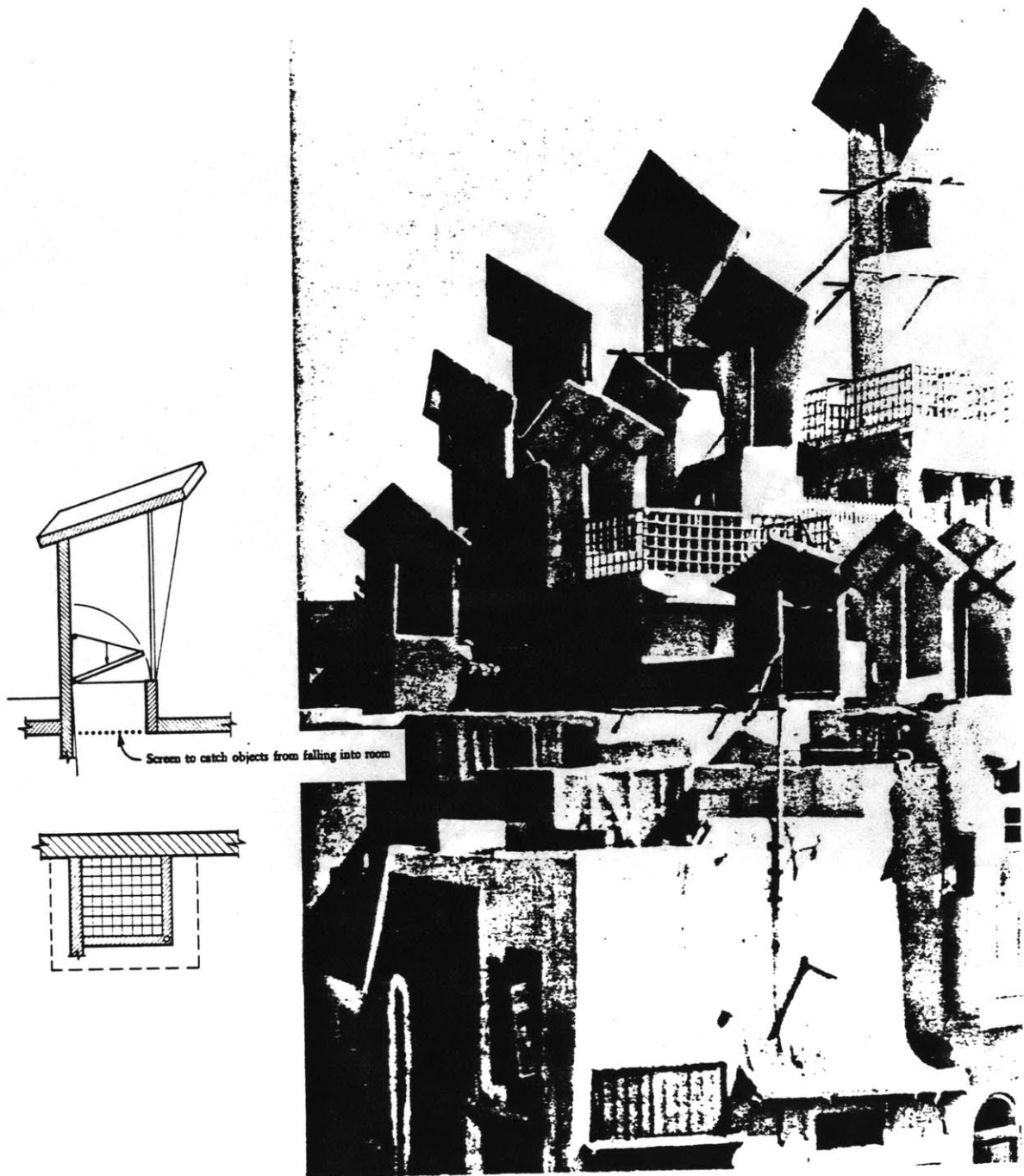

The final example in this section is an apparent reversal of all the previous ones. Instead of drawing air from below and exhausting it up high, the "bad-gir" (wind scoops) of Hyderabad, W. Pakistan, reach up into the sky and channel breezes down into individual rooms. Since the wind direction is constant, the scoops have fixed positions. Their formal response to wind becomes the skyline of the city.

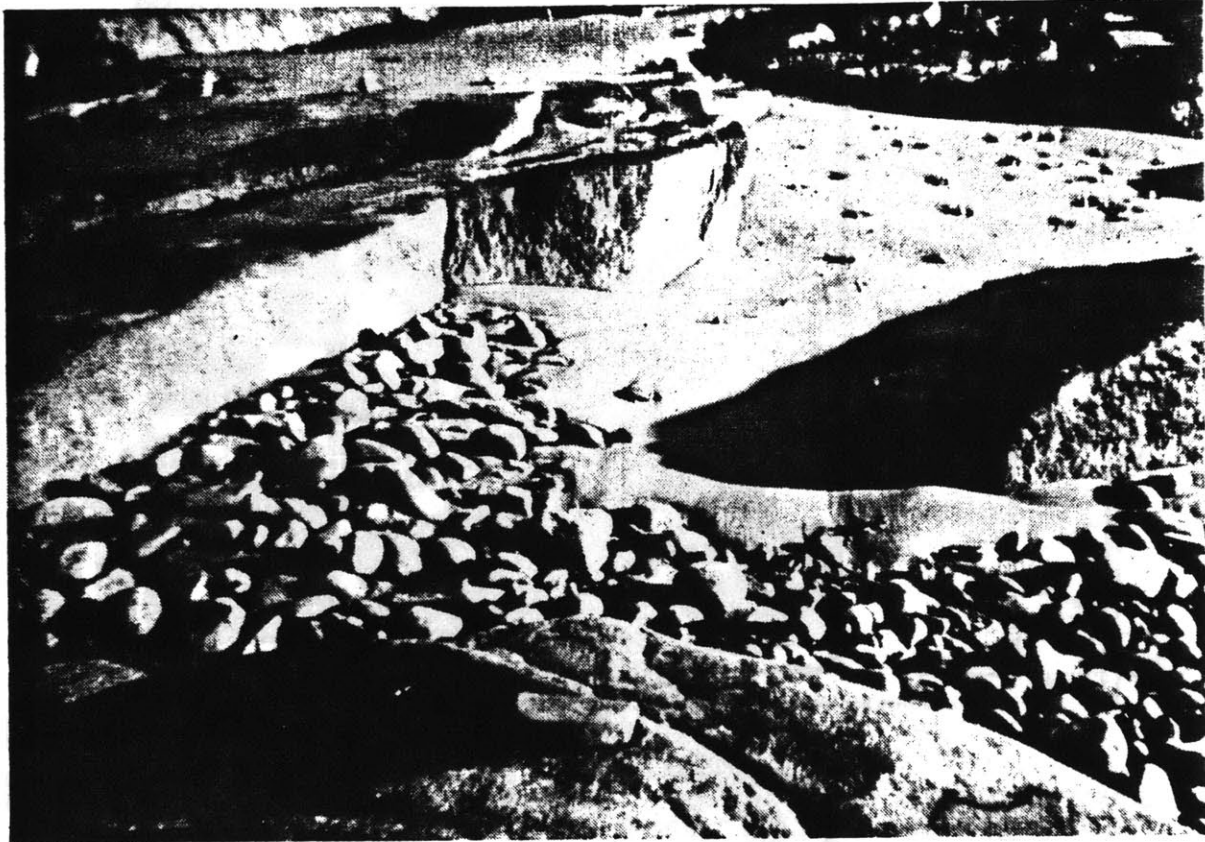

A "COLLECTION" OF ROCKS
PEBBLES
SAND
ON THE COAST OF MAINE....

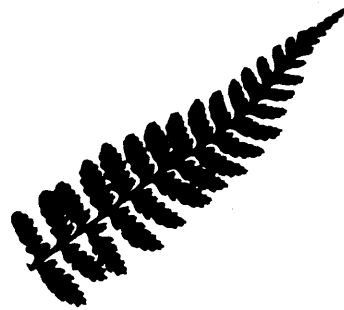

- Additions of systems
- the larger form of the fern leaf (collective) is behaving in a similar way as the smaller forms of which it is built.
 - the system is consistent (in principle) at different sizes.



Building the space

-- as one leaf/system finds itself next
to another...they "build" the space
in between; hence, built fern/form.³⁵
-- if there was no space/no light
between...the leaf would die.
-- what about buildings?



How much space does a cupped hand hold?
The volume it contains
territory it claims extends way beyond the hand itself.

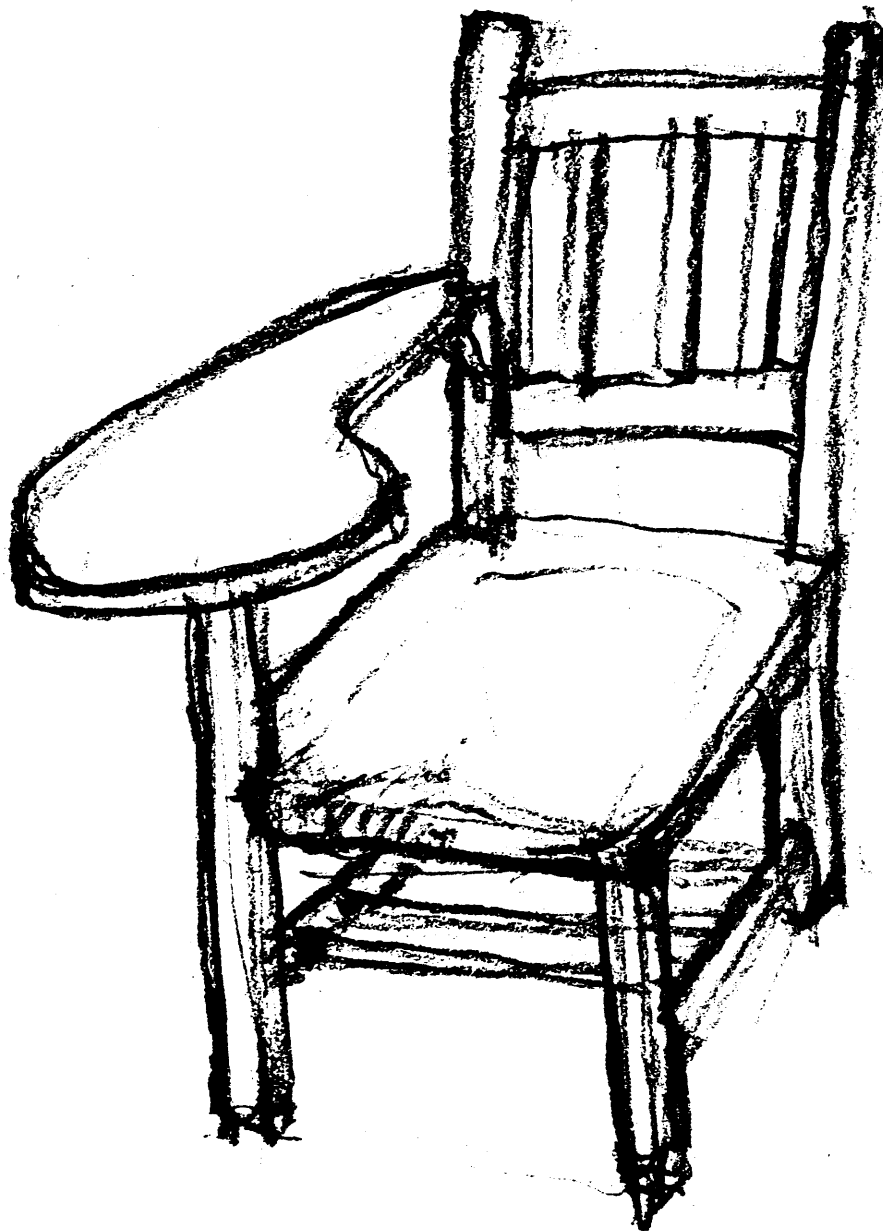

Shouldn't there be similarities between:

- the space defined by our hands and
- the space defined by what our hands build?

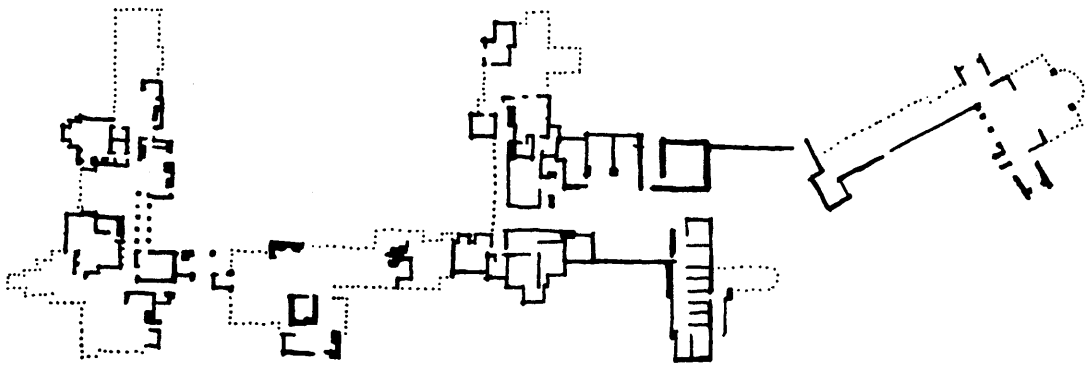
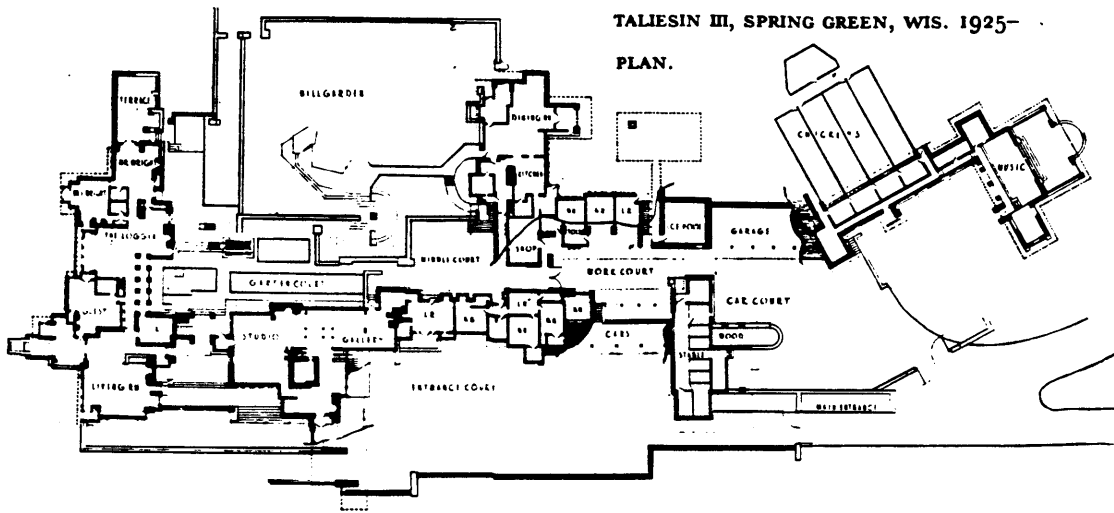

Additions of systems -- the containments (caves) vary in size and are built, like the fern leaves, with space in between (pavilions).

TALIESIN III, SPRING GREEN, WIS. 1925-
PLAN.

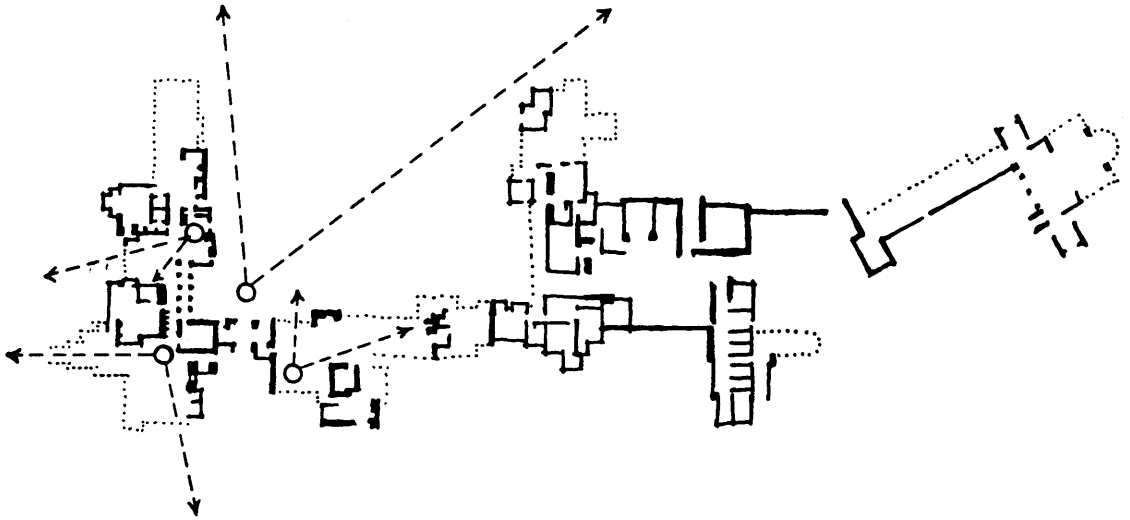
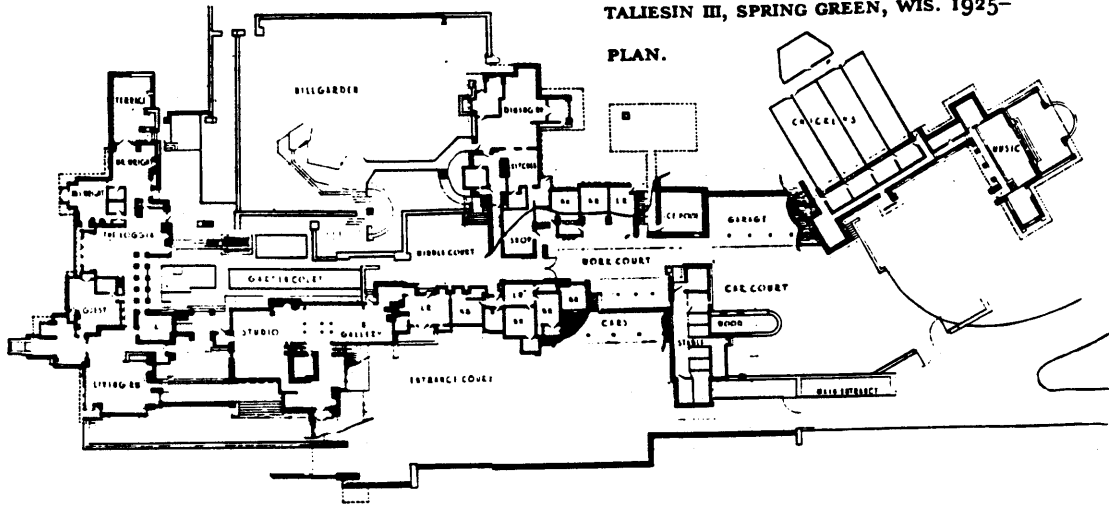

Partial containment of the surrounds

-- at a range of sizes (room to building), this organization claims territory beyond its boundaries through the displacement of wall planes.

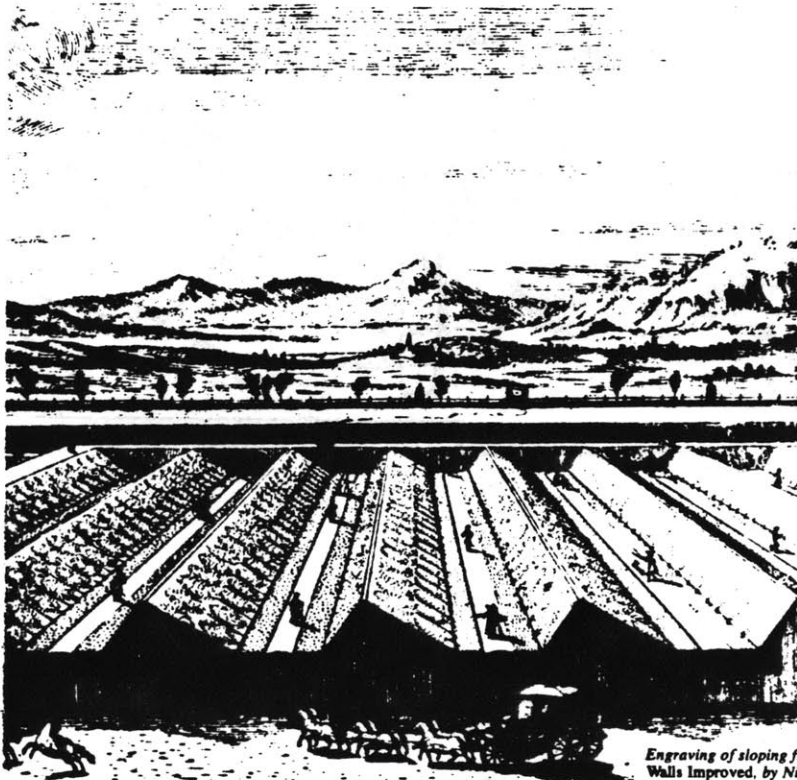

Engraving of sloping fruit walls in seventeenth-century France, from *Fruit Walls Improved*, by Nicolas Fatio de Duillier. These walls faced the southern horizon at an angle chosen for optimum year-round solar collection.

What happened here?

- the system is an extruded section that runs from east to west.
- the system adds up in the north-south direction with no space in between.

This is the predecessor of the enemy (see page 49). Its formal organization can be seen today as sawtooth clerestories and, at larger sizes, factory greenhouses.

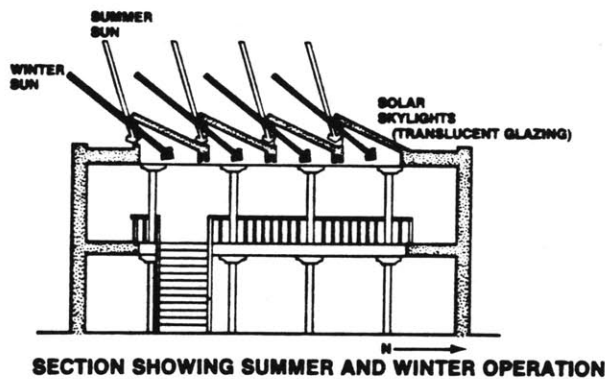

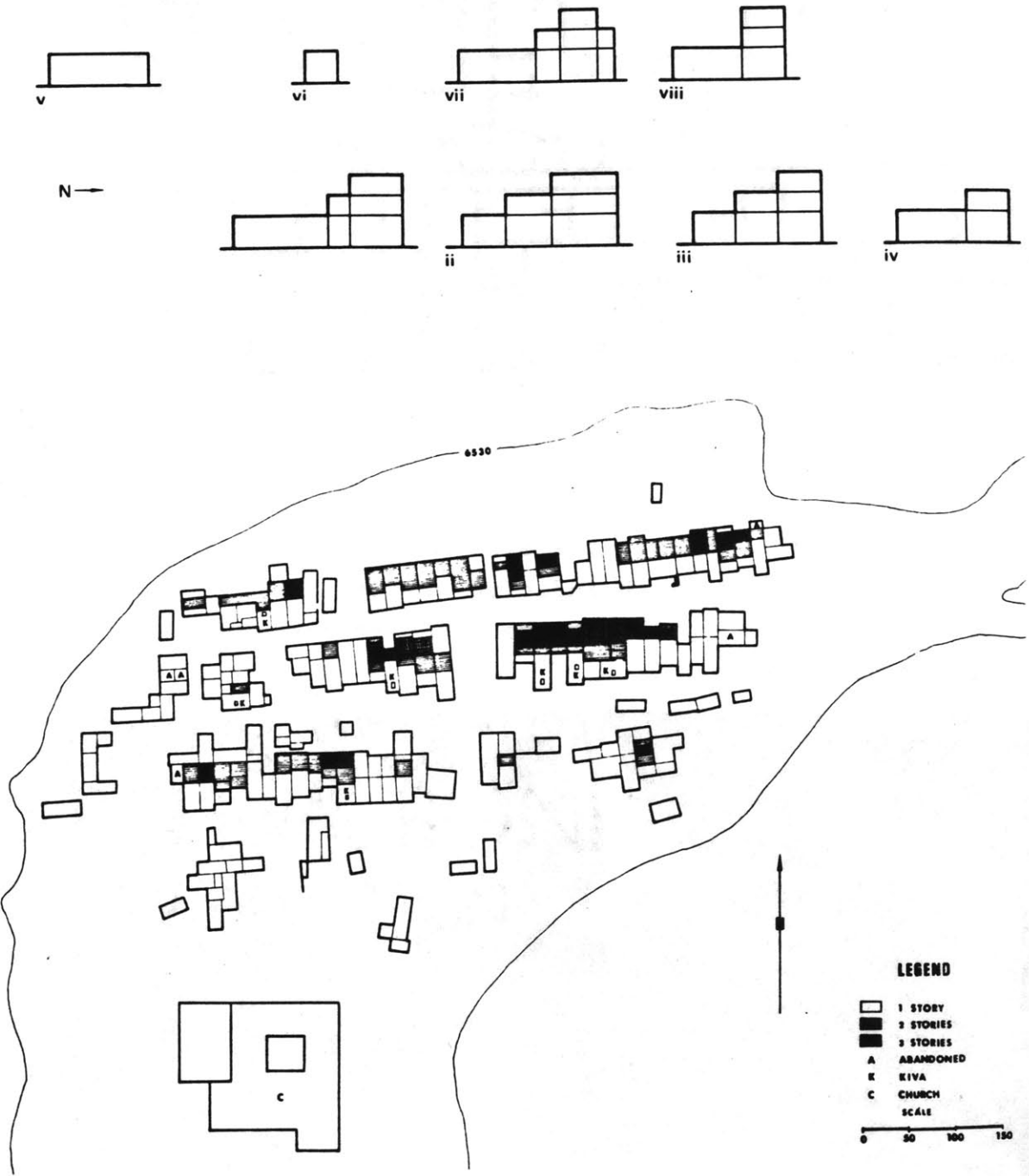

The system in Acoma Pueblo (New Mexico) is a south-facing terraced section. Incremental growth occurs along the east-west axis with space (streets) between additional rows. Variations in dimension allow horizontal extensions into the street to define usable outdoor space.

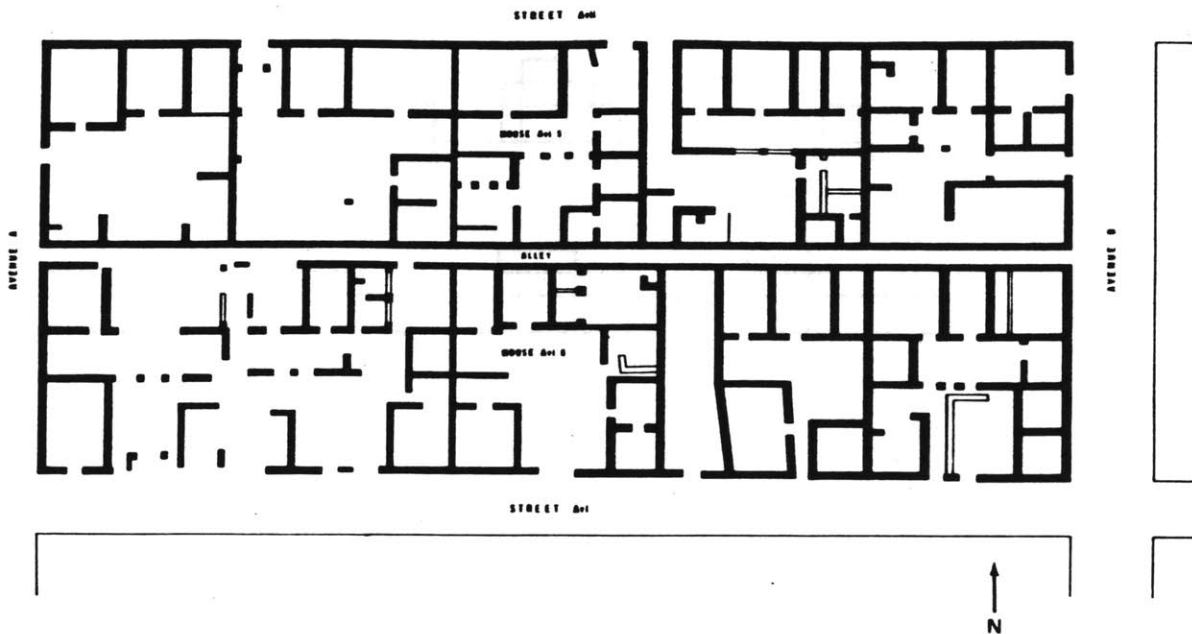

In ancient Greece, the system of a south-facing enclosed court was maintained with infinite variations in plan. The agora was the major public space built to echo this principle at a larger size.

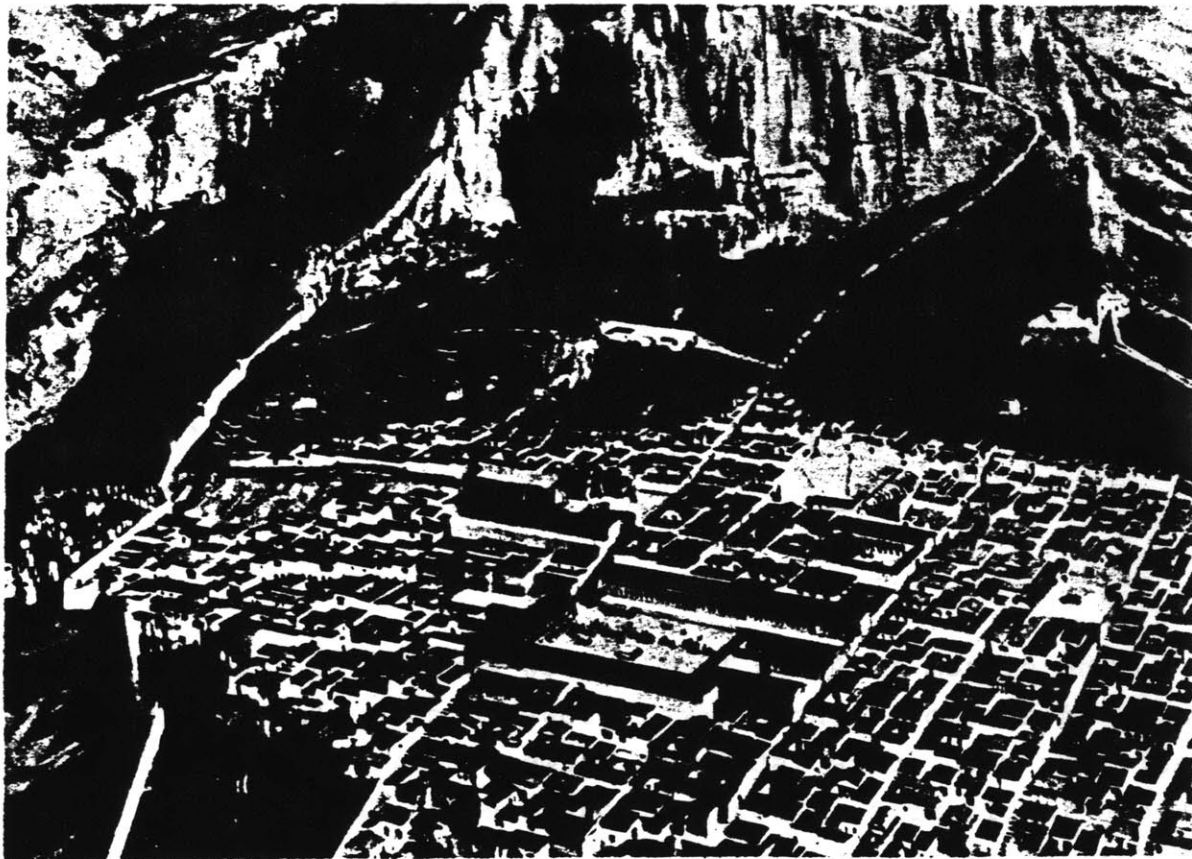

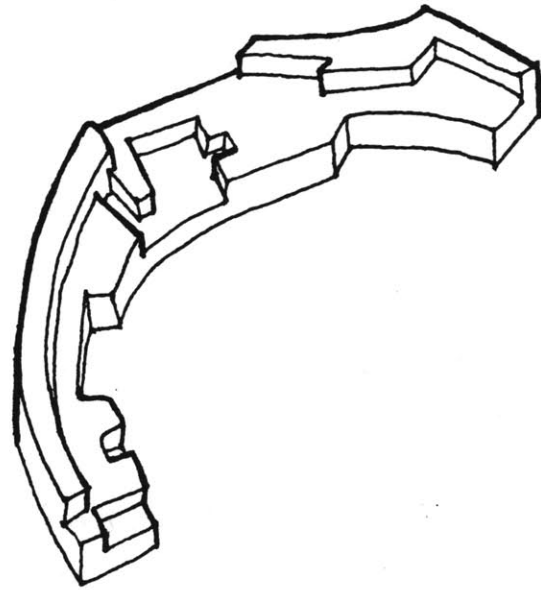
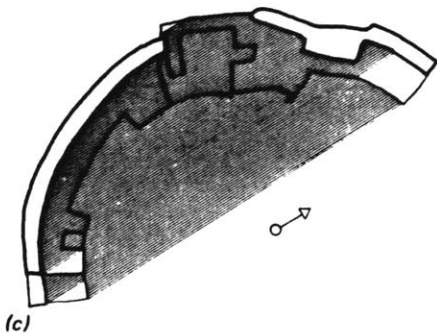
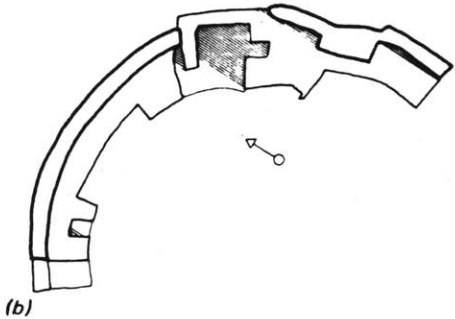
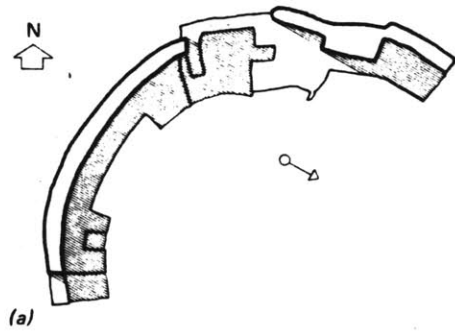

(a) Sunset, summer solstice;
 (b) sunrise, winter solstice;
 (c) sunset, winter solstice.
 Such relationships show
 that the Bonitians used the
 dynamic interaction of sun-
 light and building to mark
 the passing seasons with
 great precision.

Old Pueblo Bonito is a terraced section built in a crescent. The surfaces collect light for warmth while the orientation marks the seasons. The system defines outdoor space at the community size as well as the room size.

4. DESIGN VOCABULARY

sketch development. . .

How should we build in light?

How should we use our references: light-heat
: light-form?

We are given the landscape and the light in which to build.

How do we respond to gifts such as these?

Psalm 24:1

The earth is the Lord's,
and the fullness thereof;
the world,
and they that dwell therein.

We are given: landscape ..God-built... and light...
man-built

We find and transform: materials and site...

We then build: the habitable landscape in light.

We have light. We have materials.

We should consider how to build:

surfaces to receive light.

Principles of light-heat
light-form

should fuel the design process/should be the building's
organizer rather than be considered after the fact:

"Oh, yes, I guess it's time to
design the windows now....

How about putting a few over here?"

... another unpunished crime against form.

How should we build in light?

glass - mass

open - closed

light - dark

opening - surface

How should we digest references and re-use them in the develop-
ment of a design vocabulary?

We can begin by feasting on "essence of light-heat:"
 collection -- transmitting surface
 storage -- absorbing surface
 distribution -- radiation into the space.
 Two basic ingredients--glass and mass--are combined into the
 four basic food groups shown here.

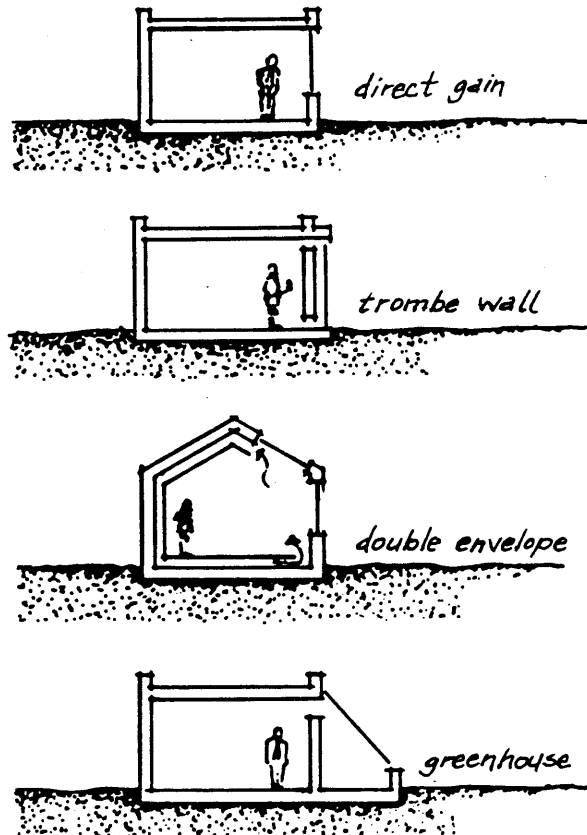

By having a taste of each of the basic food groups, a well-balanced diet can be maintained. An inclusion of complementary organizational aspects are essential for operative health:

- DIRECT GAIN -- the space itself is the system of heat gain.
- TROMBE WALL -- the primary mass is in the light.
- DOUBLE ENVELOPE -- air circulation brings heat to more surface.
- GREENHOUSE -- build zones of light-dark.

Re -use:
-newal:
-surrection:
-versal: of some historical
-view: responses to light - heat

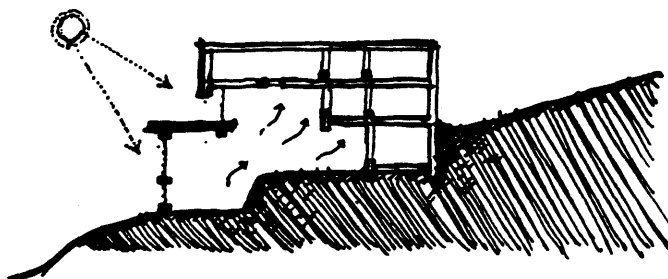
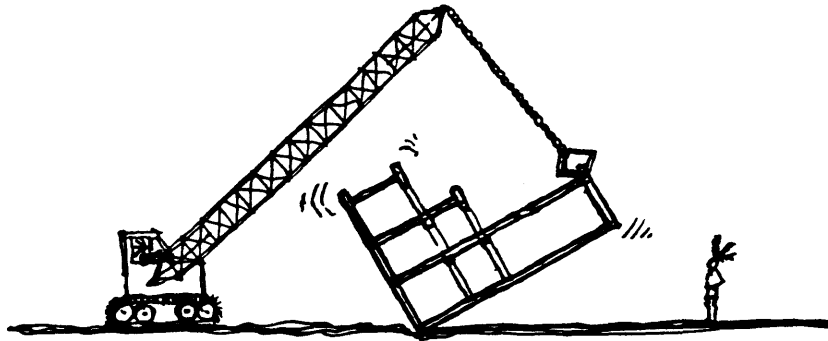
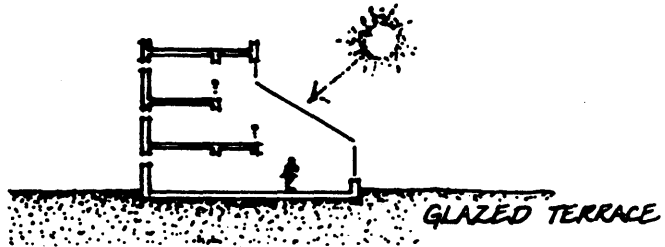
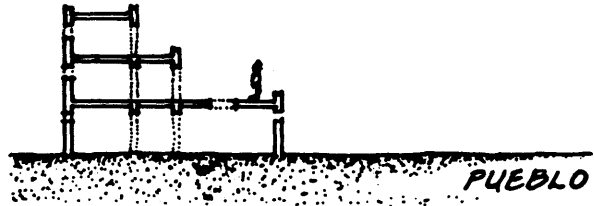

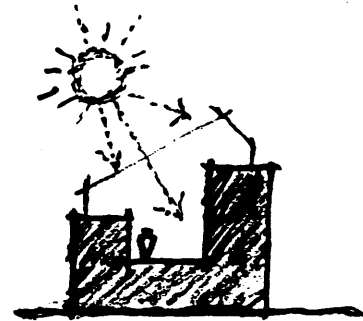
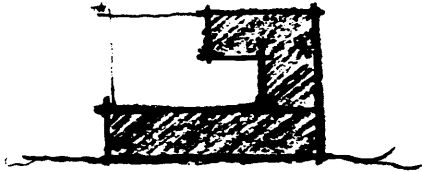
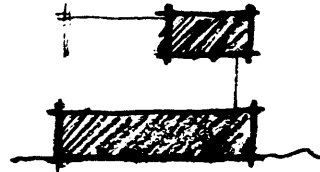
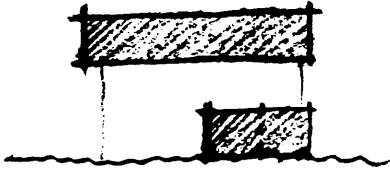
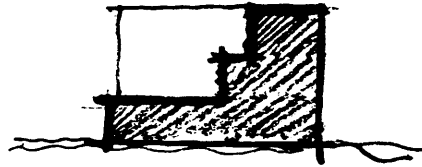
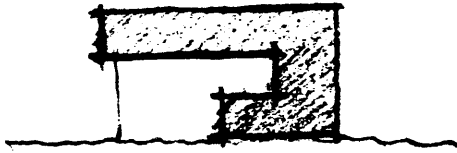
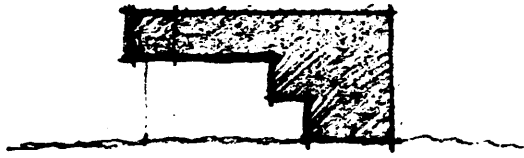

In pre-glazing days, a terraced exposure to the southern sky built many surfaces in light. One way to translate this form into present day is to glaze it "in situ." Another is to reverse the diagram and allow the surfaces to become absorbers of infrared traffic.

Using either of these approaches by themselves would render another version of the enemy--the extruded section.

Therefore, a range of transformations could/should occur that would build a host of associations between the glass and the mass.

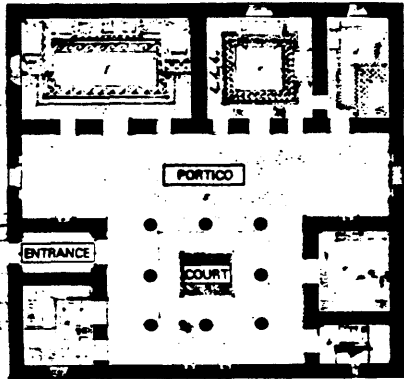
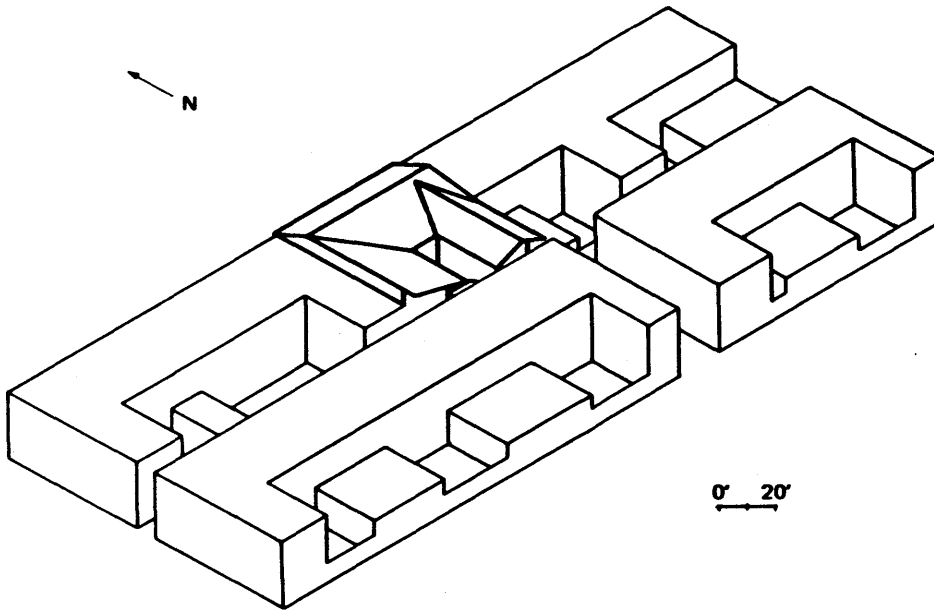

The urban dwelling in ancient Greece demonstrated a spatial interlock of: open-closed
light-dark
court-containment.

This organization defined an open, south-facing court through the distribution of the masonry containments: a reasonable diagram for a private urban use. By displacing a portion of the containments, the enclosed court could "breathe" and become a part of a larger organization, i.e., a portion of a building or a more public use territory.

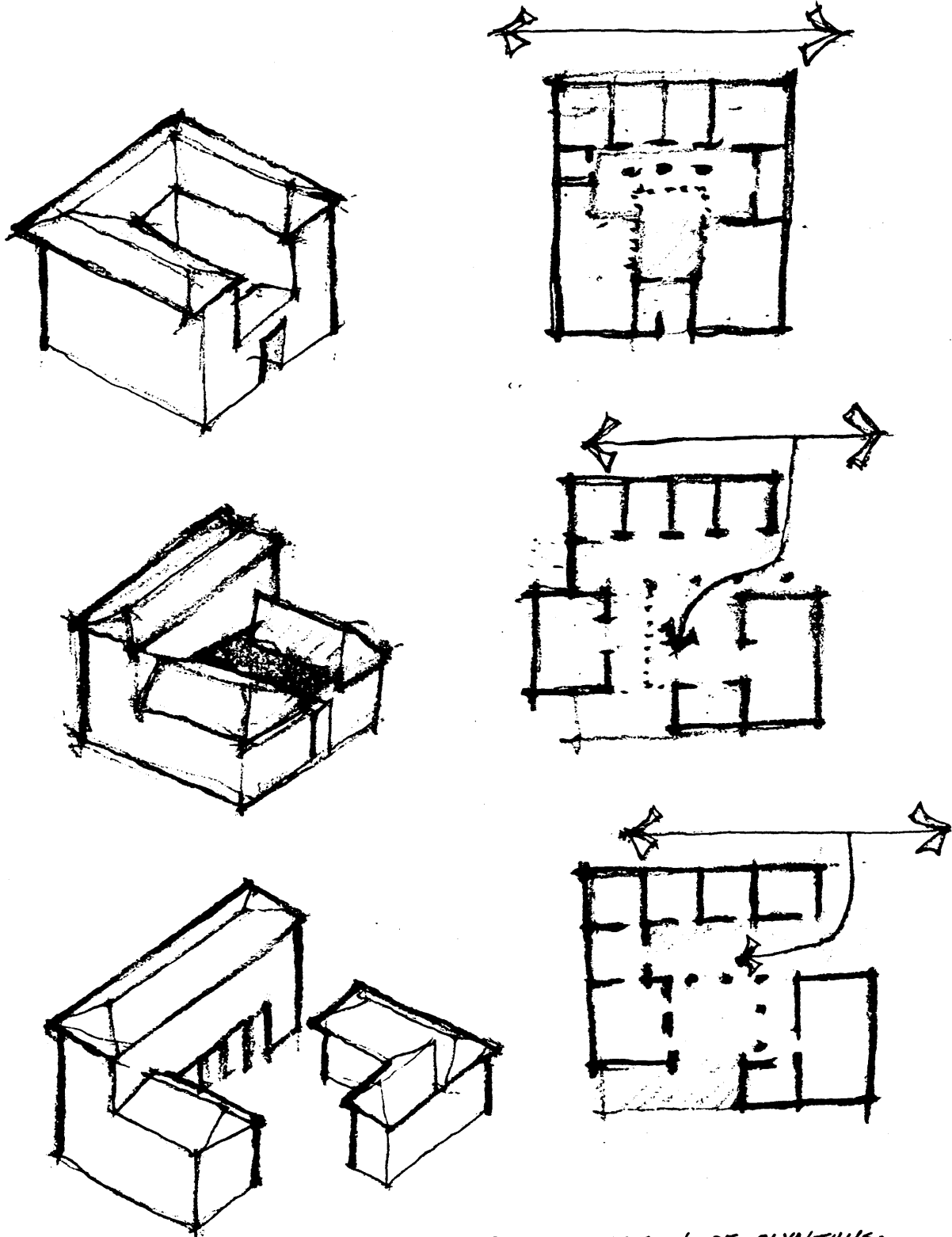

TRANSFORMATION OF OLYNTHUS:

LETTING IT BREATHE;
BUILDING SPACE BETWEEN....

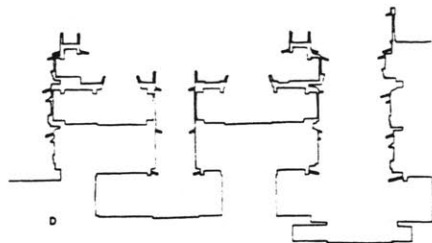
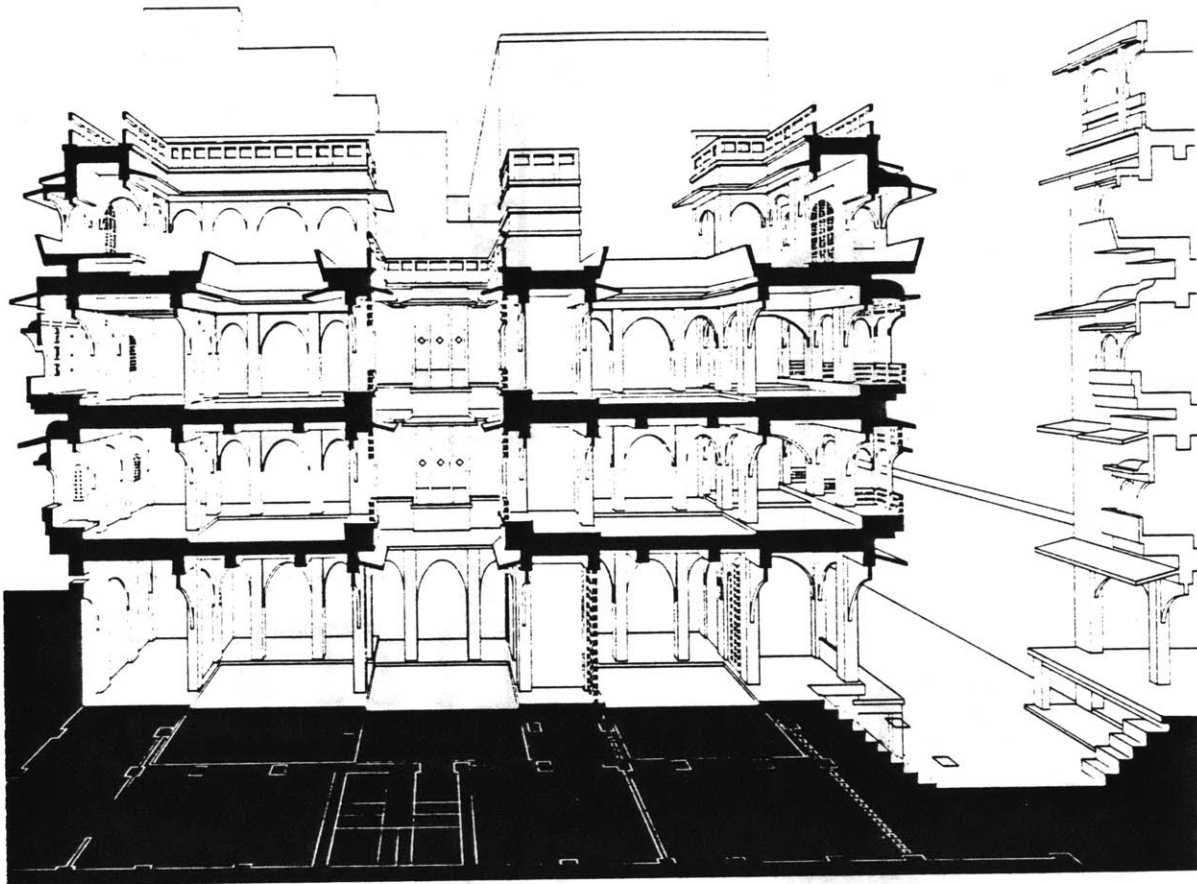

The buildings in Jaisalmer are successfully zoned to increase shading of the surfaces and to accelerate ventilation for cooling. When the sectional profile is tipped 90° and glazed on its south side, a deep wall zone is built. The surfaces are now ready to receive direct light and infrared traffic.

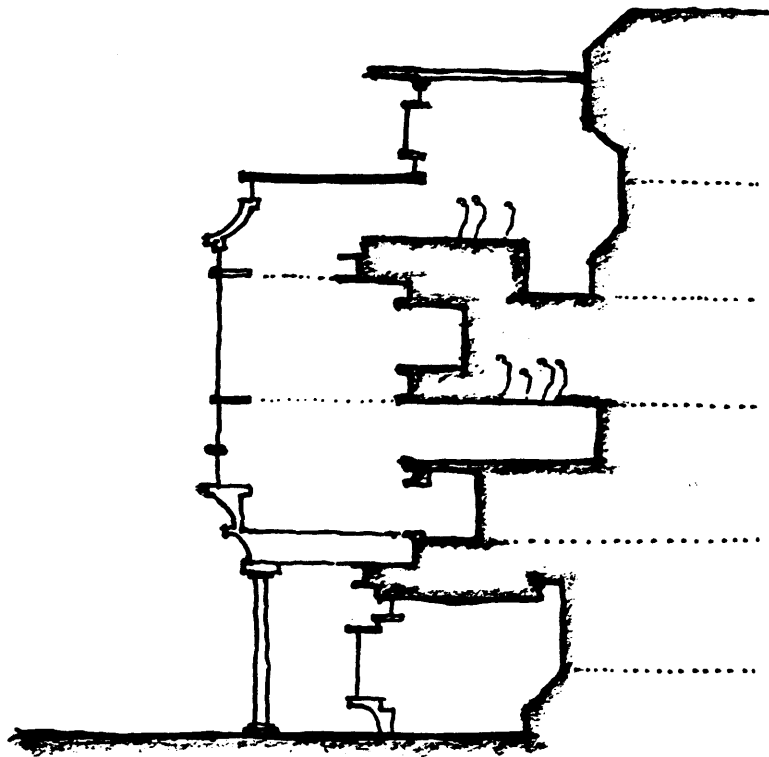
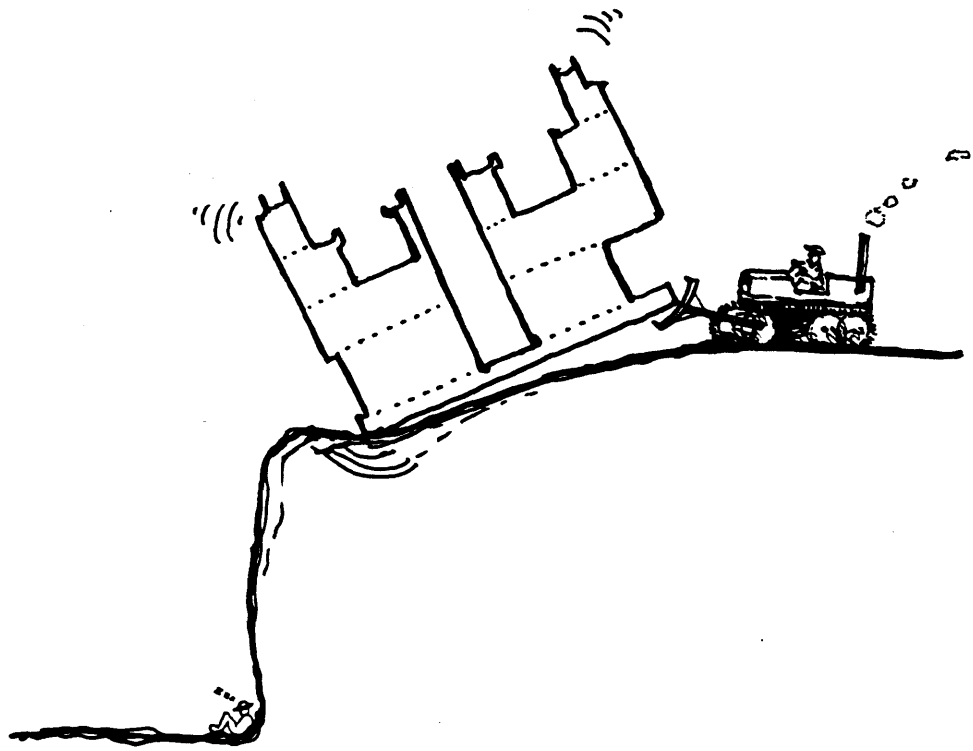

RE-USE OF JAISALMER:
BUILDING DEEP ZONES
OF SURFACES IN LIGHT....

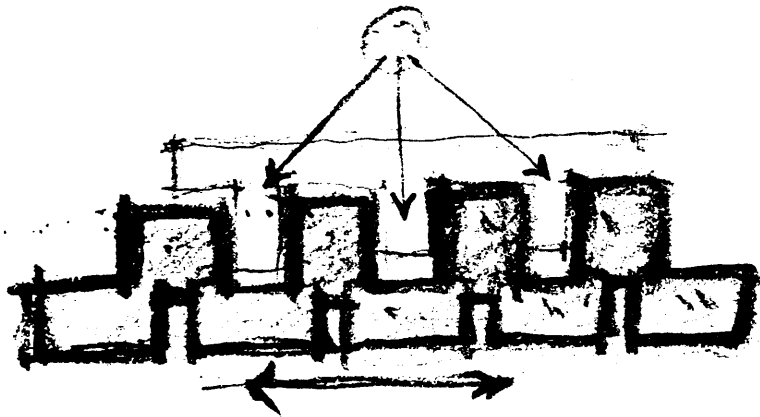

The task is simple: build surfaces to receive light.
The formal response should build a range of places within such
an environment:

from cave to pavilion
dark to light
ground to sky.

Each in its own place, yet reaching out to greet one another.
The ground works its way up to meet and interlock with the sky
that is working its way down.

How is such a building organized? How do light and sur-
face come together?

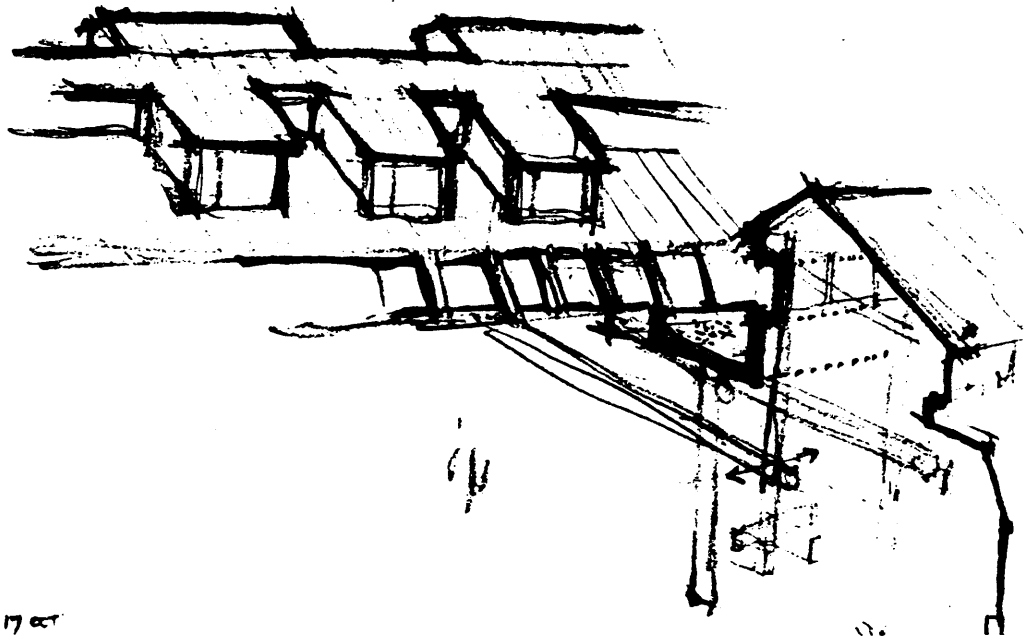
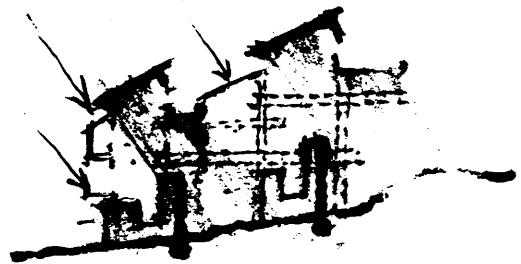
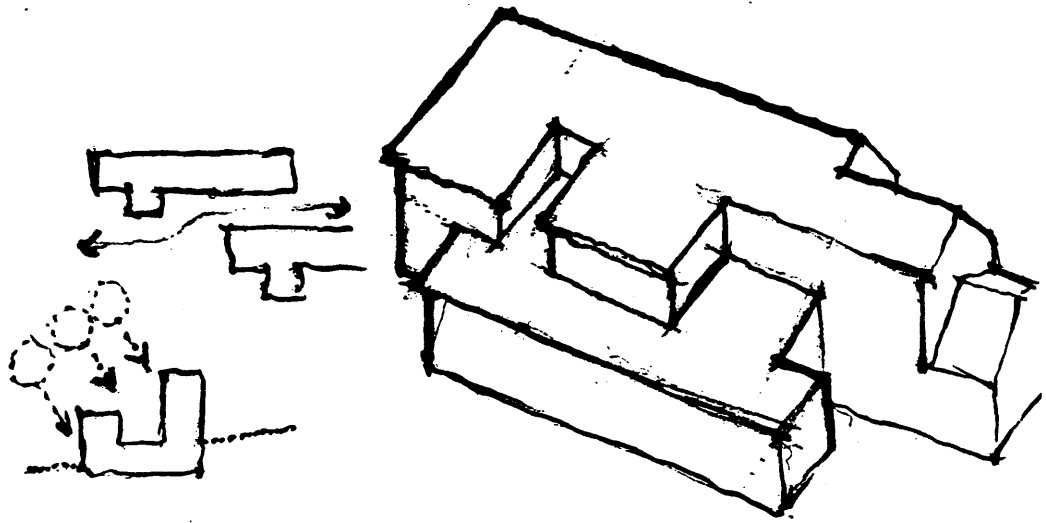

1700

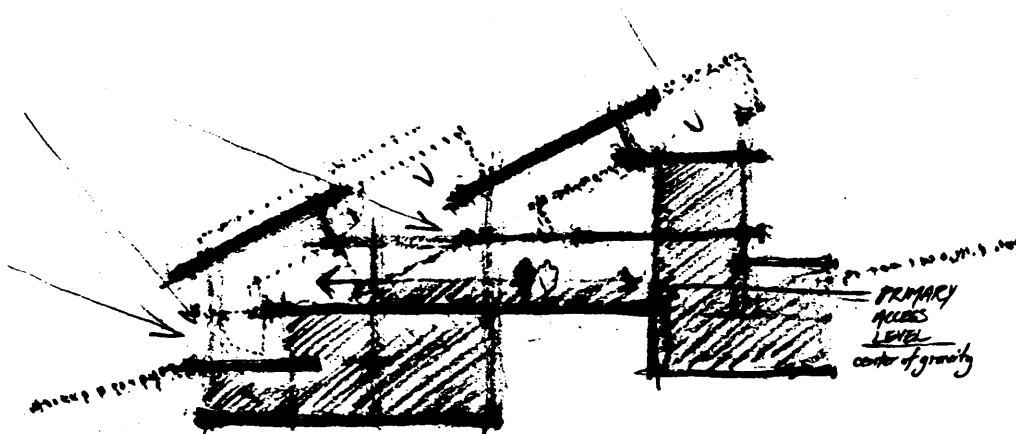

Early sketch studies began to examine:

- how a building can become more permeable to light.
- how horizontal surfaces can be placed within a framework to intercept/reflect/filter direct light or allow it to pass.
- how a base section can be used to generate a range of possibilities for inhabitation.

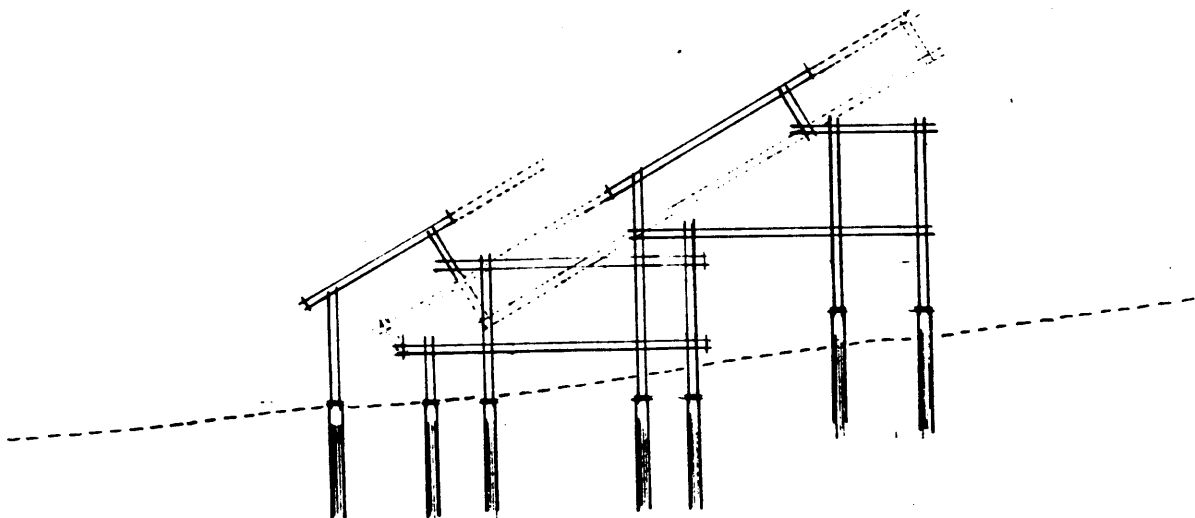

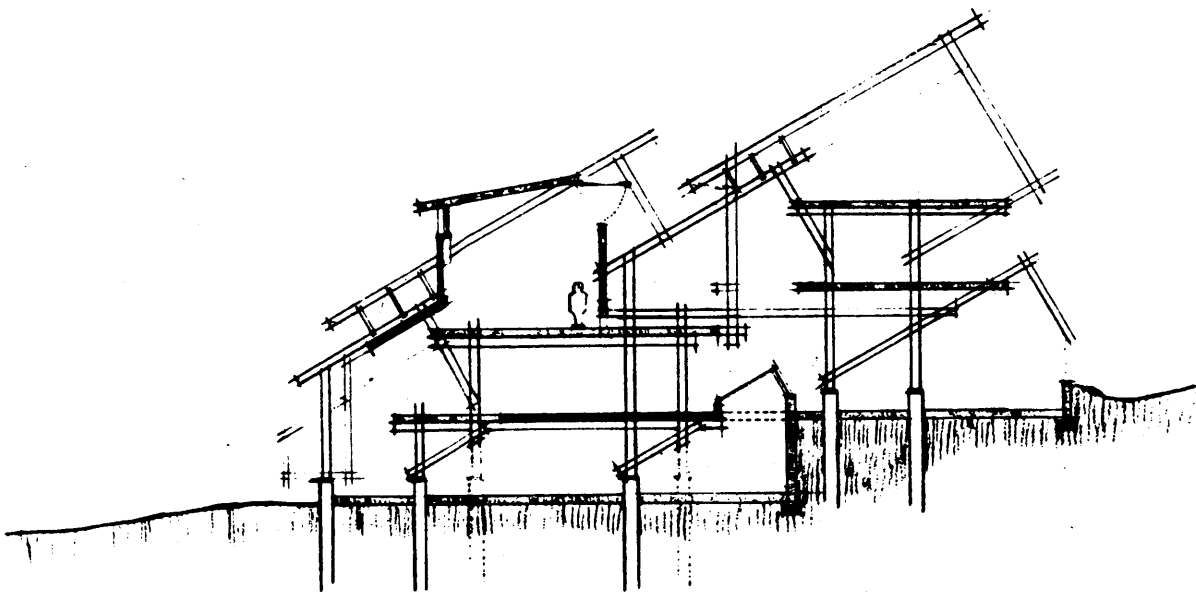
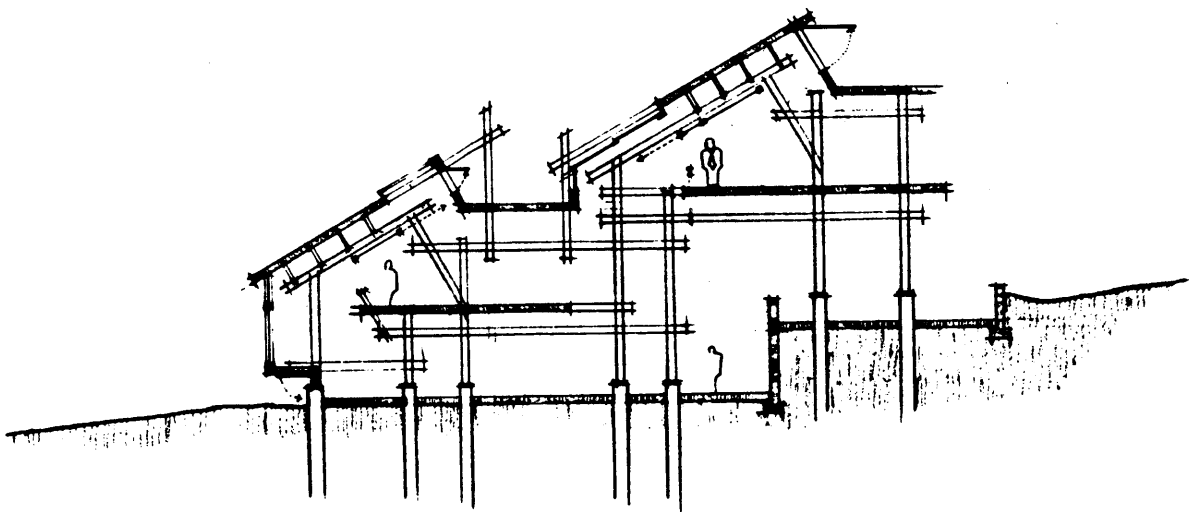
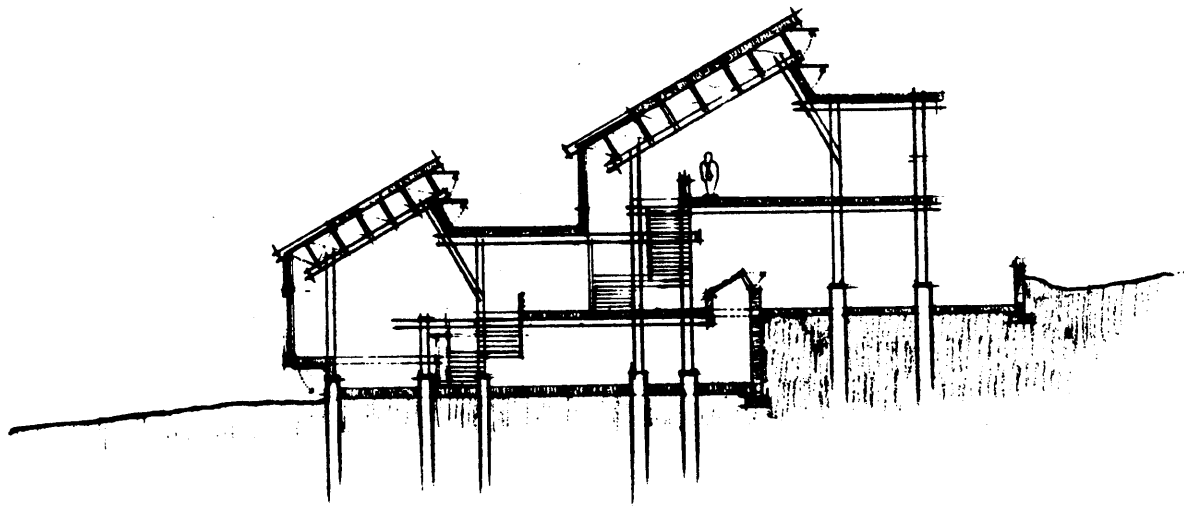

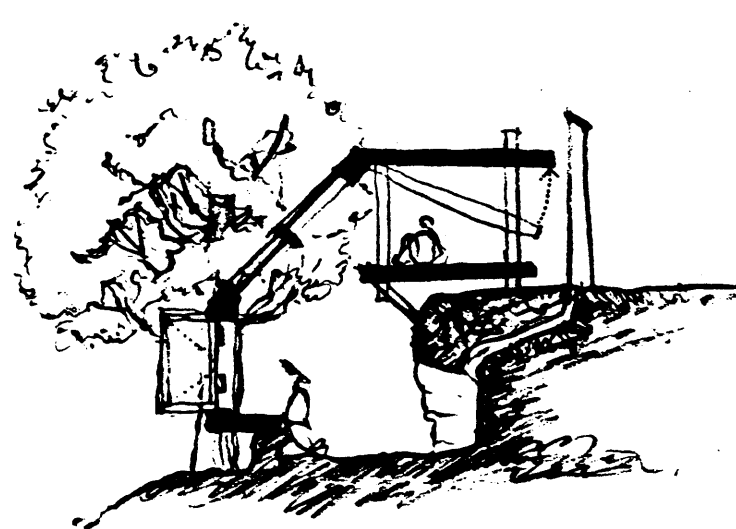

adding to the primitive cave...
220083

The frame studies were useful for studying the permeability of a building's organization in terms of its profile and placement of horizontal surfaces. The next step was to study the organization of vertical surfaces as well: the "critical" mass.

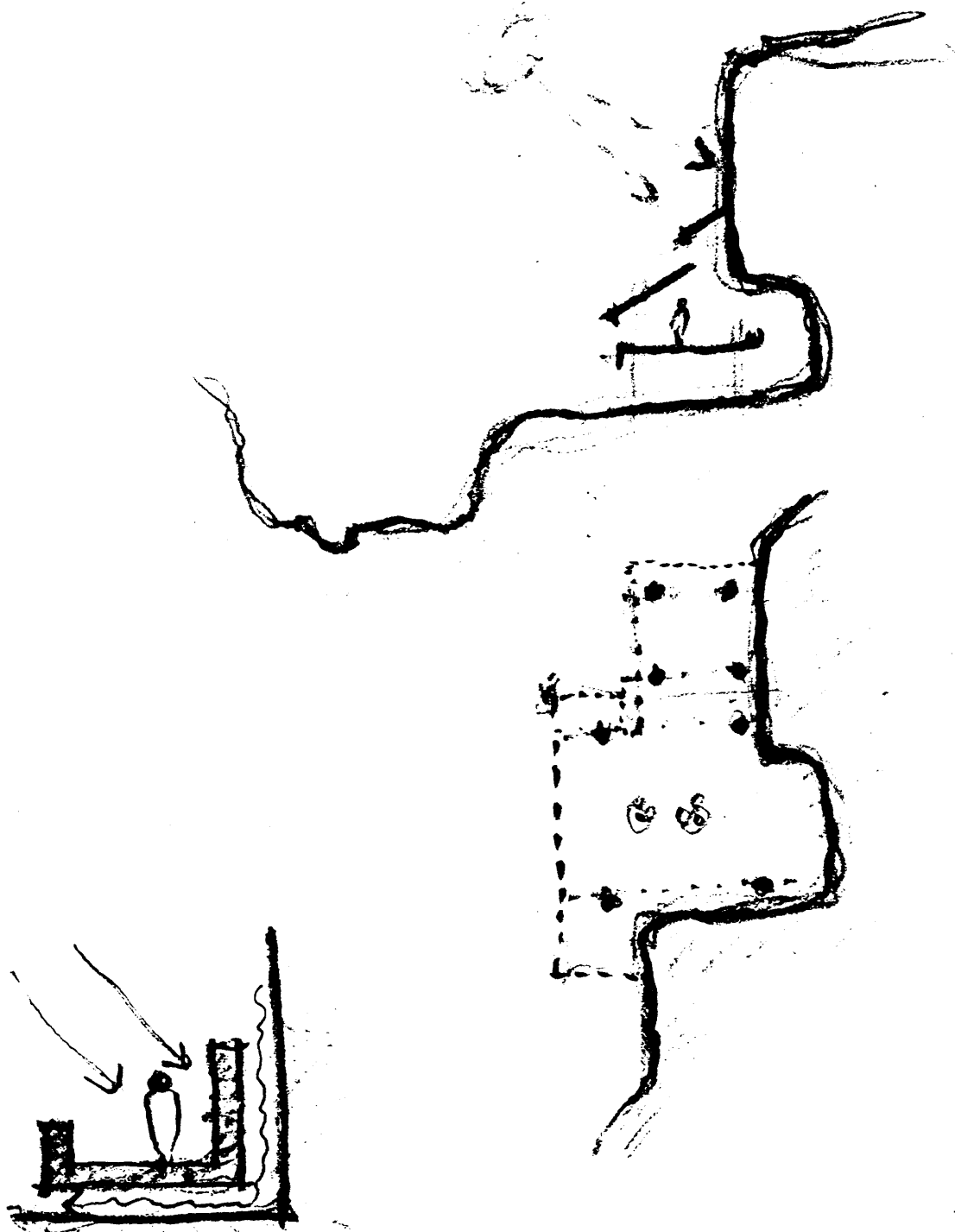

double envelope
radiant mass

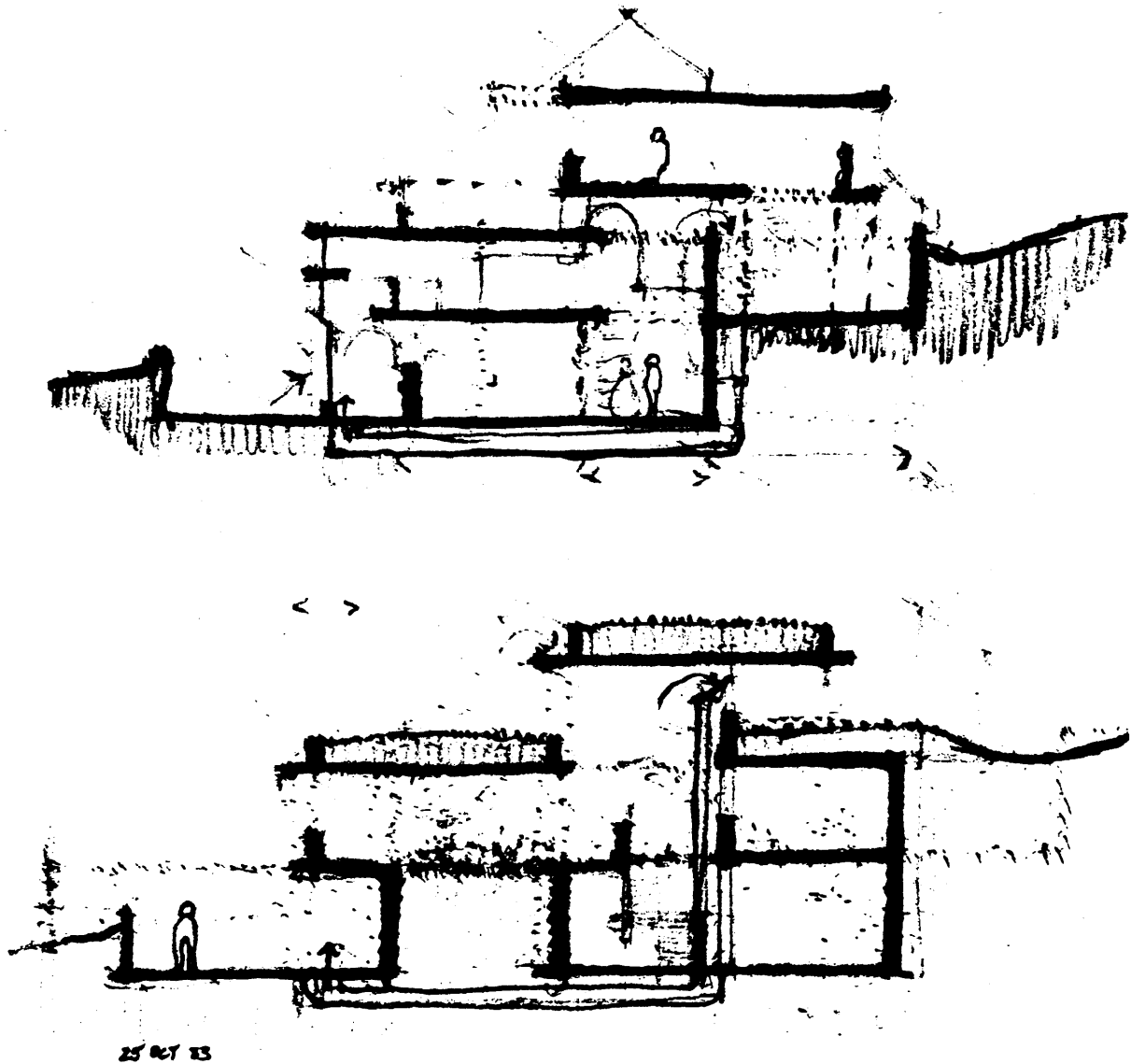

These sketches show the chronological development of the next stage of the study:

- two major zones of collection are located: at the perimeter and within the heart of the organization.
- the largest openings are to the south; smaller openings (plus internal reflections) provide every space with bilateral illumination.
- the primary mass wall (sketch opposite page) is located in the space and is a major organizer of access-use.

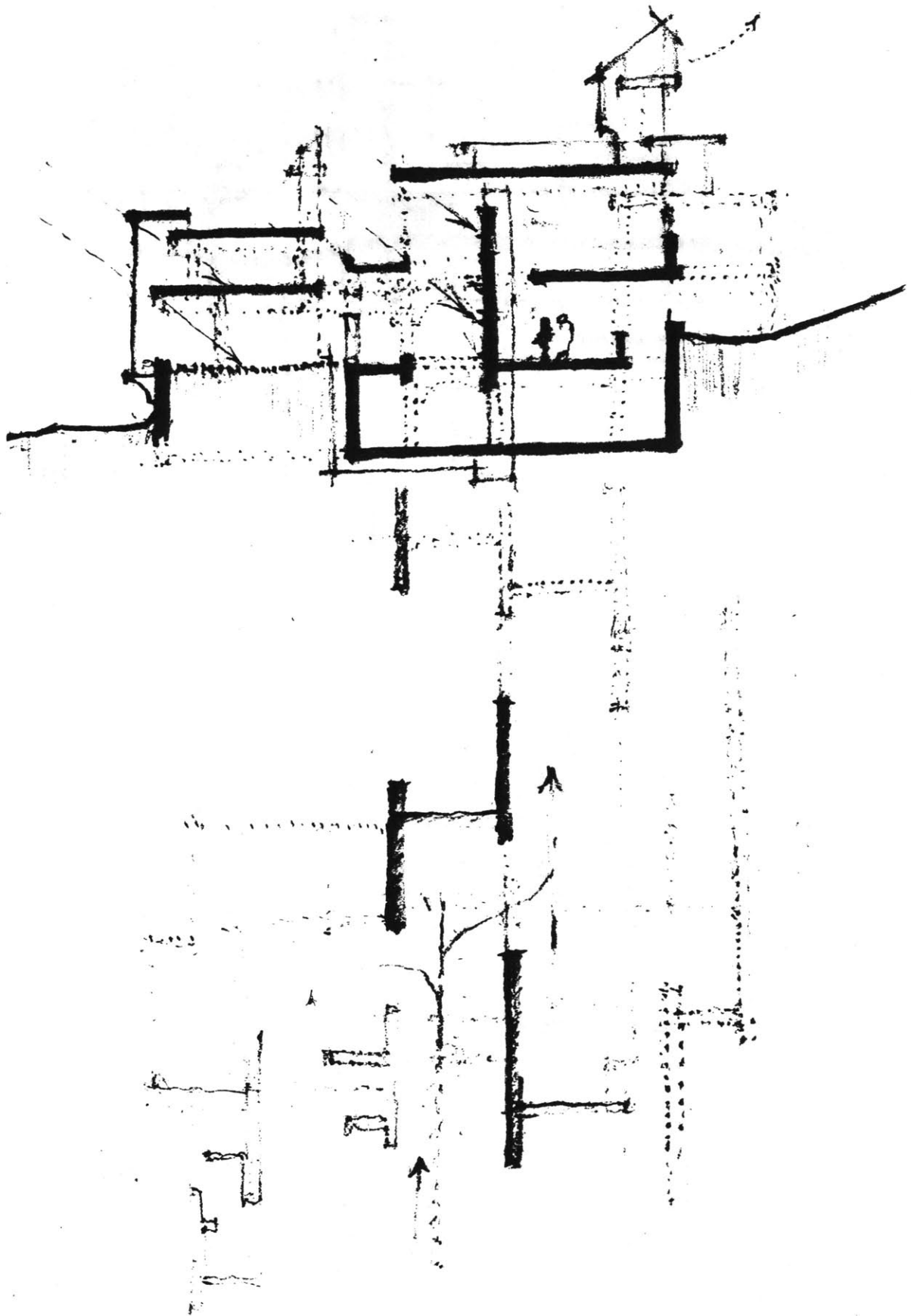

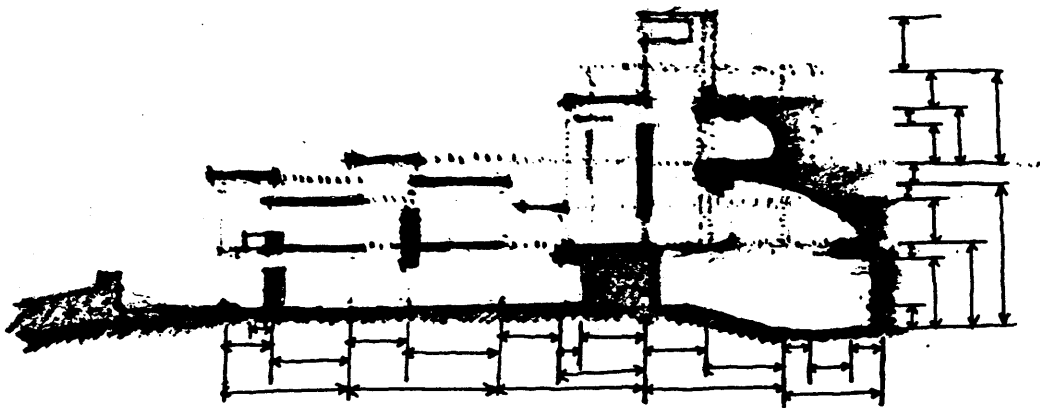

*Zoning DIAGRAM
dimensions of light, solid, territory*



Deployment of Mass Wall

A porous cave:

- alternating zones of light-dark organize the building.
- the mass wall is a broken line/a spatial spine.
- light enters from on high, always reaching deeper into the space.

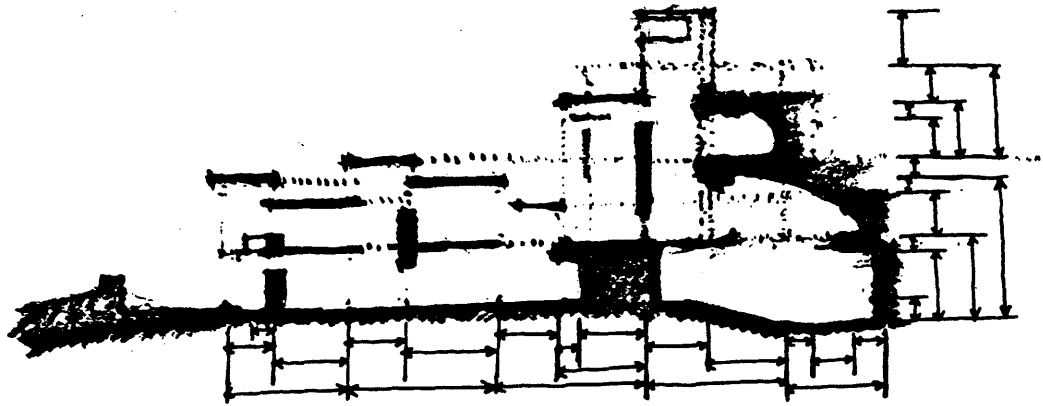

*Zoning DIAGRAM
Dimensions of light, solid, territory*

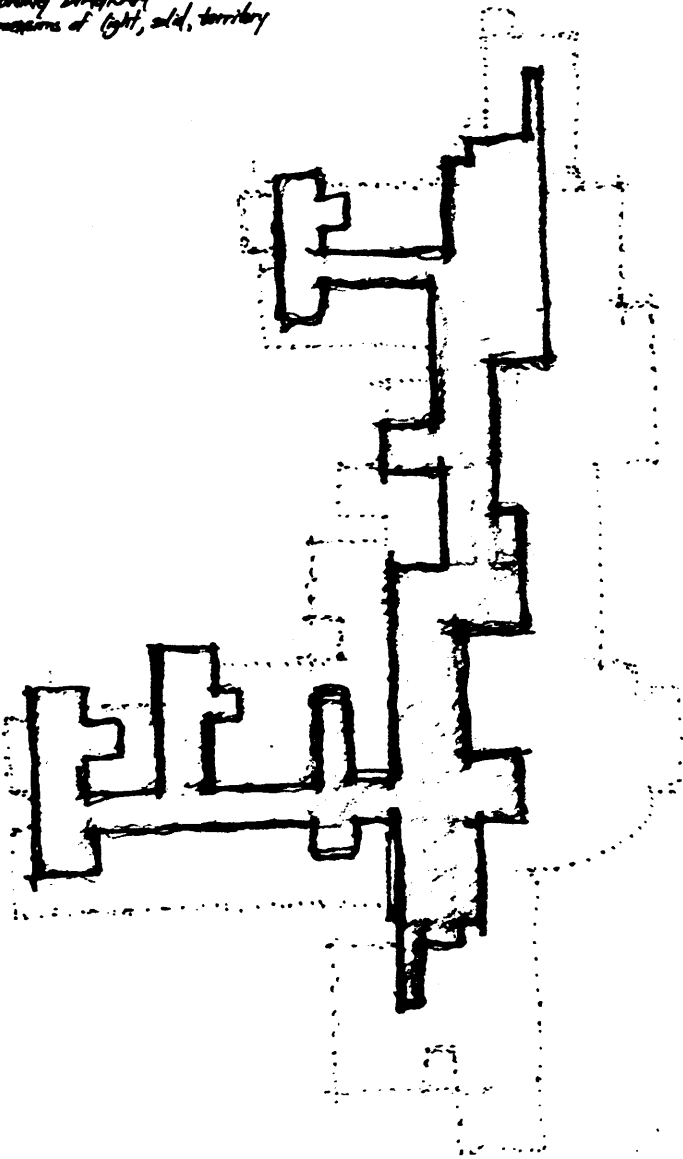

"Form of the Light" (above)

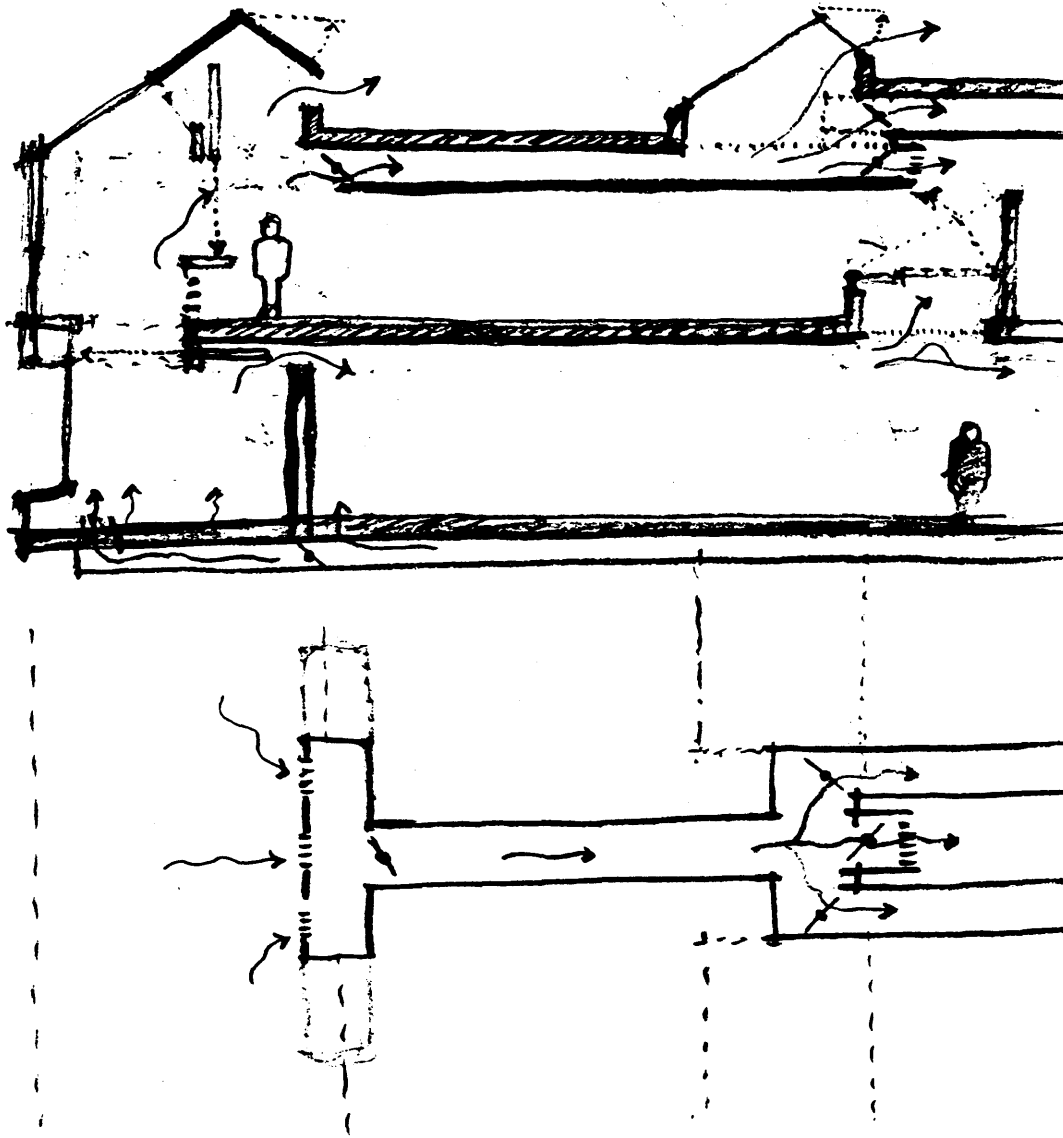

The movement of heated air over more surfaces charges mass with radiant heat. Exhaustion of heated air cools surfaces in the summer months. These activities are some of the form determinants for the organization of a building.

The idea of permeability works horizontally to allow warmed air (light-heat) to convect through the interior in several paths. Ducting and fans could be used to accelerate movement and/or to swing through privacies that may be less porous.

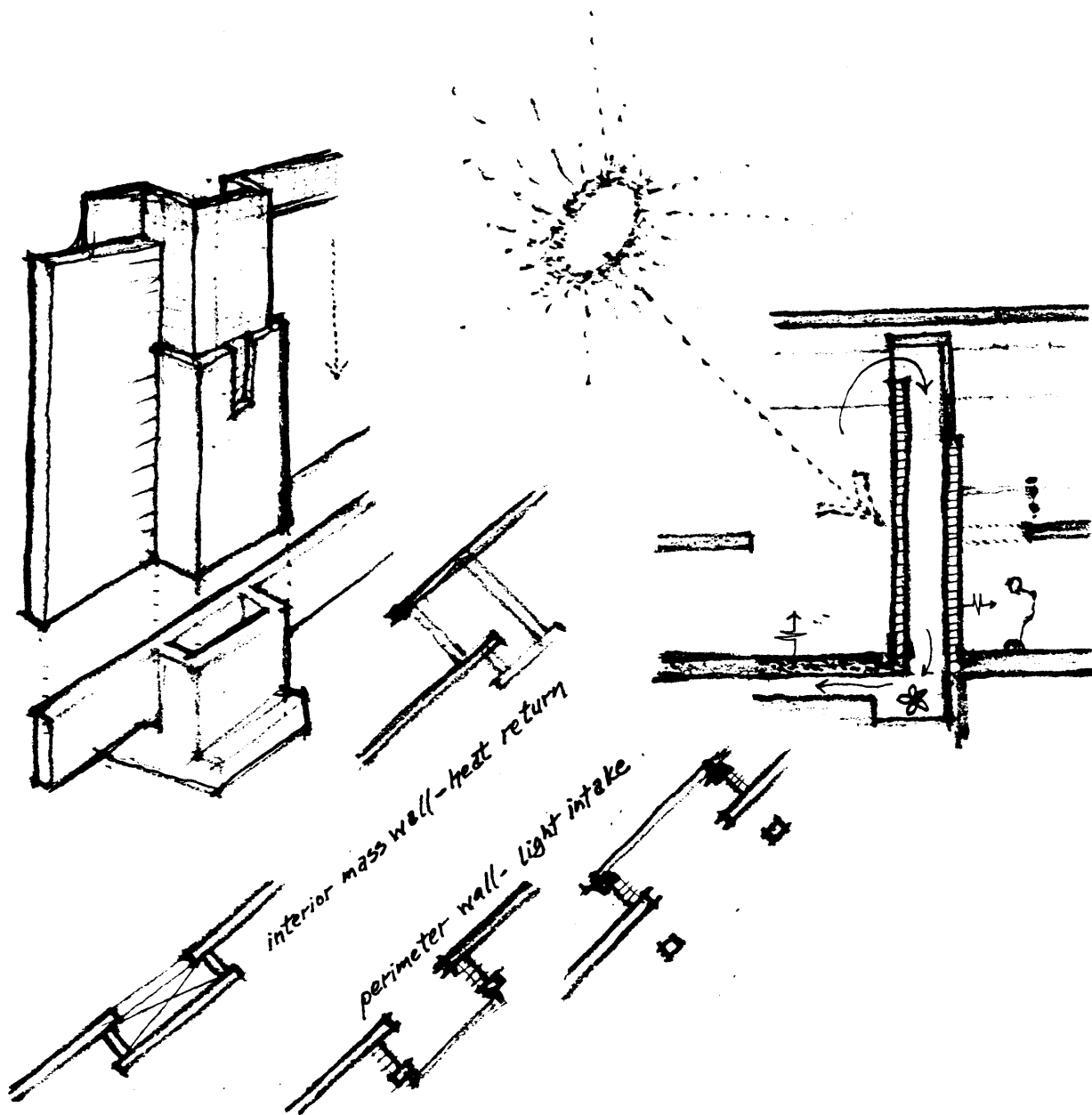

Vertical return of air (light become heat):

- a masonry duct built as part of the mass wall.
- glass block above: "thick" light associated with the substance of light becoming heat.
- the direction of air movement (down) is shown and "built" by the extension of the glass block into the masonry.
- the duct dimension could/should be seen in places at the perimeter: admitting light yet to become heat.

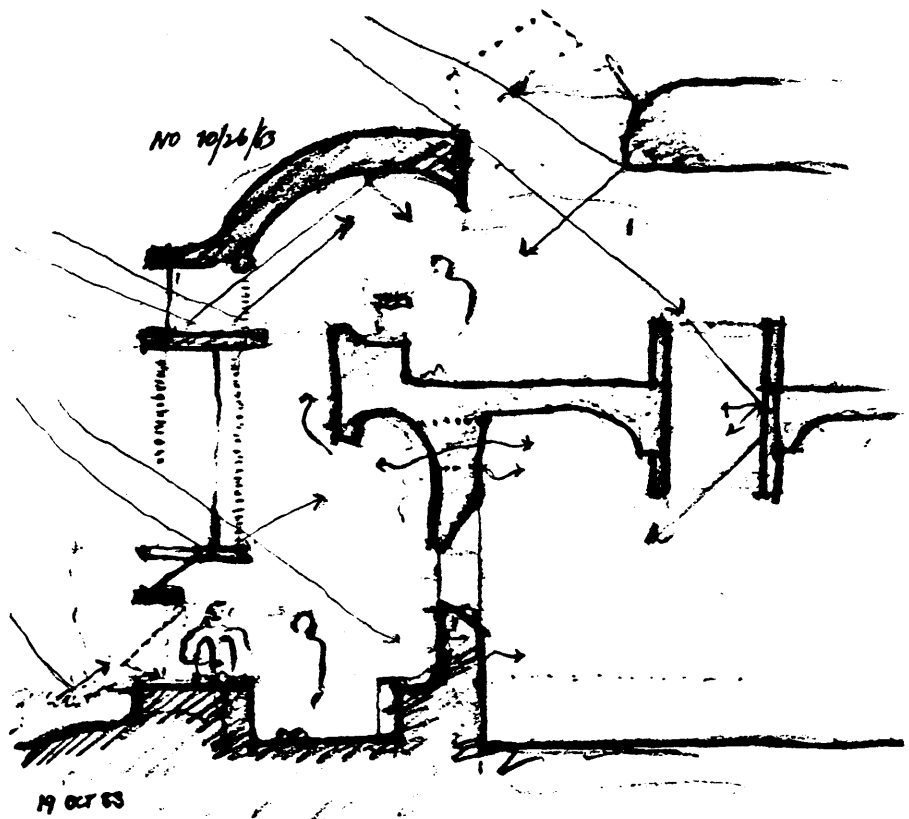
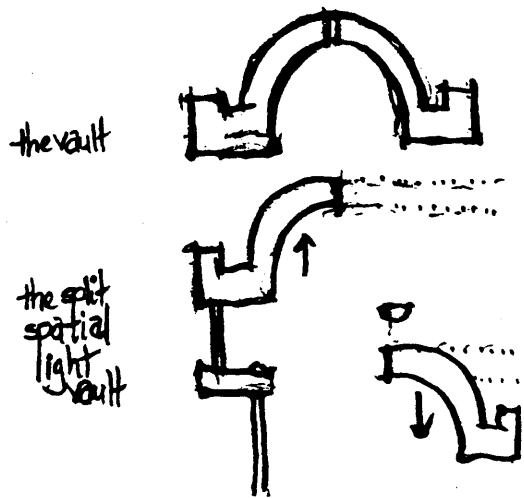

The perimeter light zone:

- spatial organization of surface to receive light-heat (direct and infrared traffic) and to encourage convective flow.

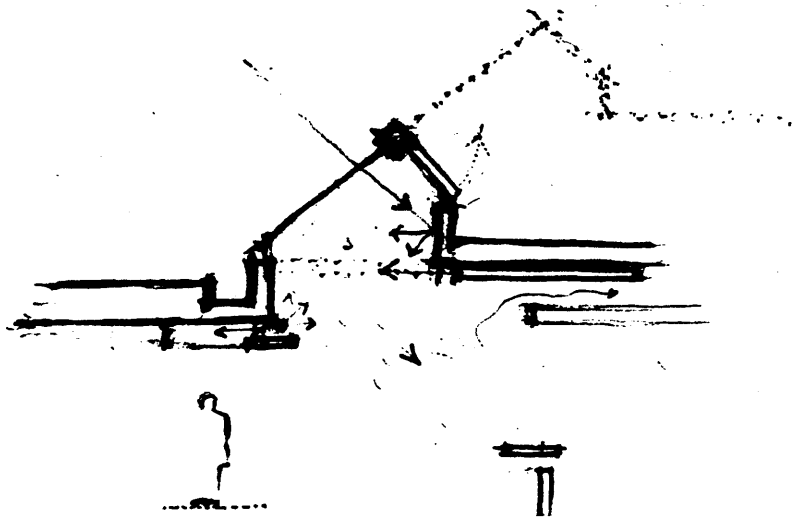
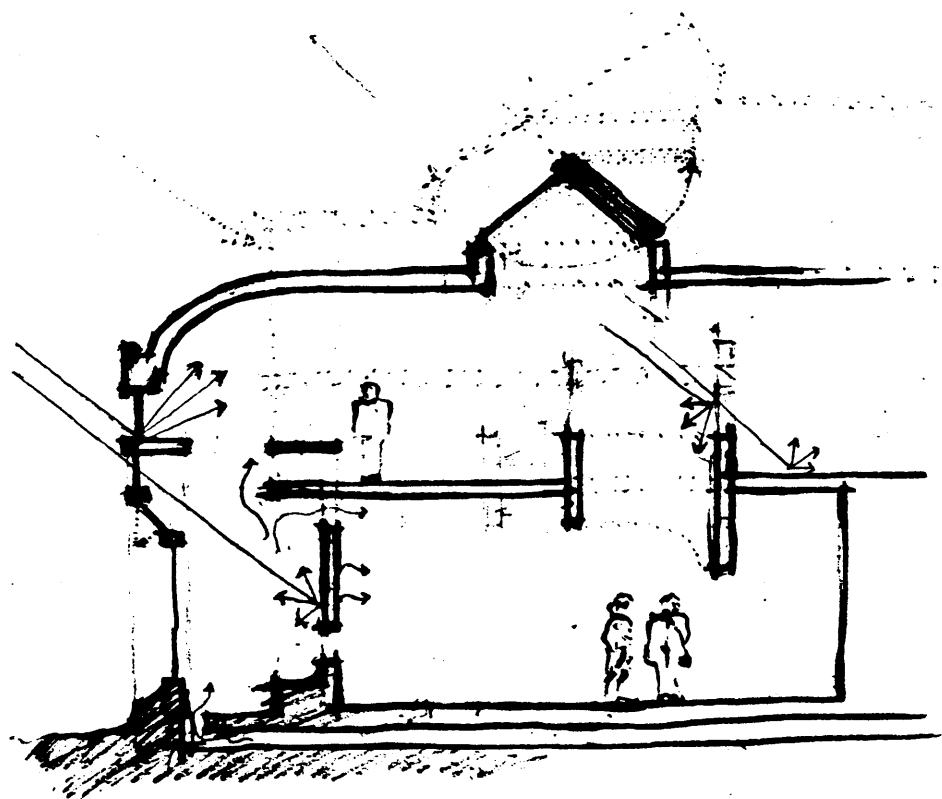

24 oct 03

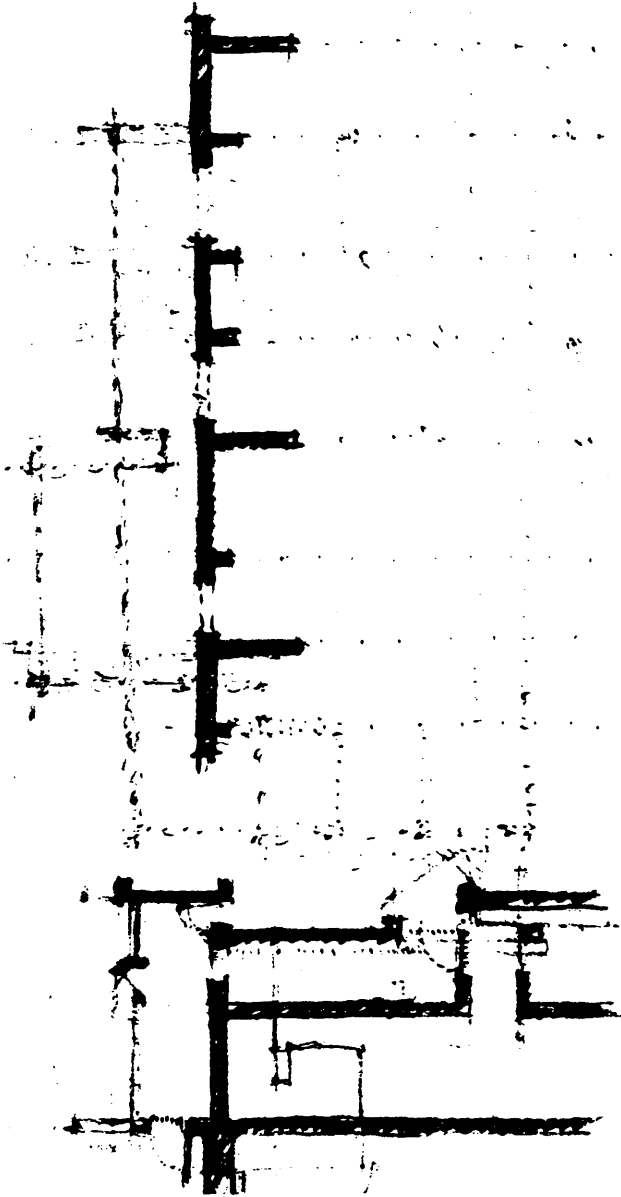

28 OCT 83

- vertical extension of perimeter zone introduces bi-lateral light with the option of air exhaust.
- variations of the glass-mass relationship can occur by displacement of the wall, thus allowing a deeper penetration of light.
- study of screening devices to filter, intercept, or reflect incoming light-heat and to redirect convective flow.

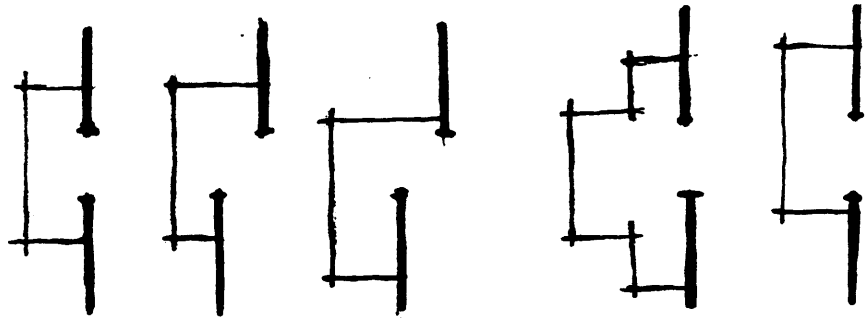

PLAN
surface + glazed
perimeter system
variation...

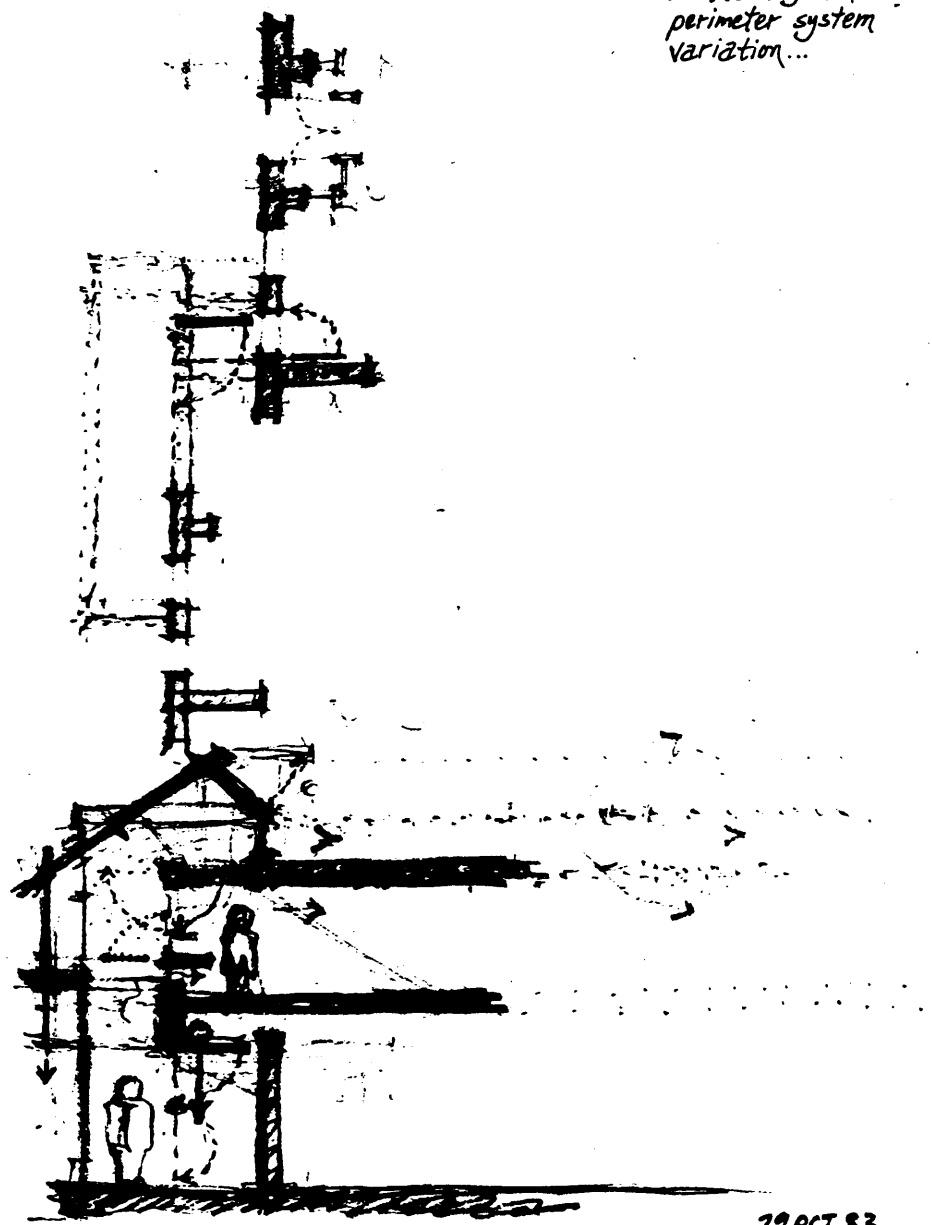

29 OCT 83

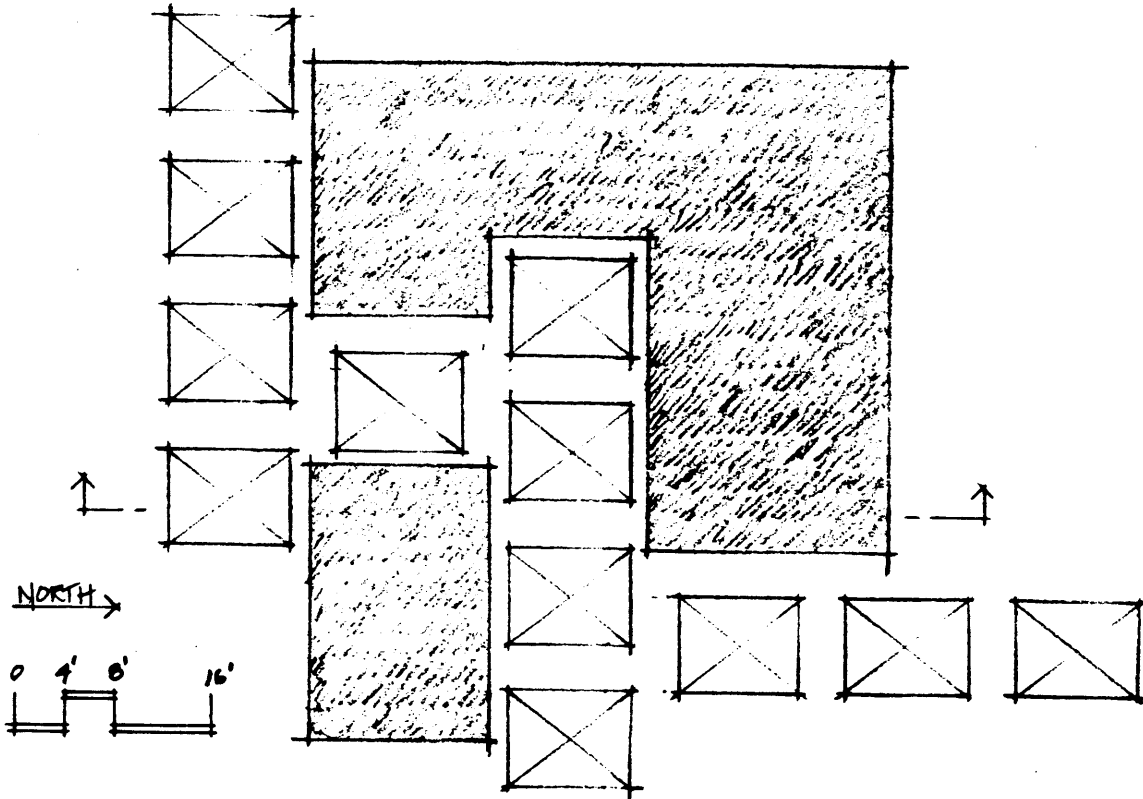
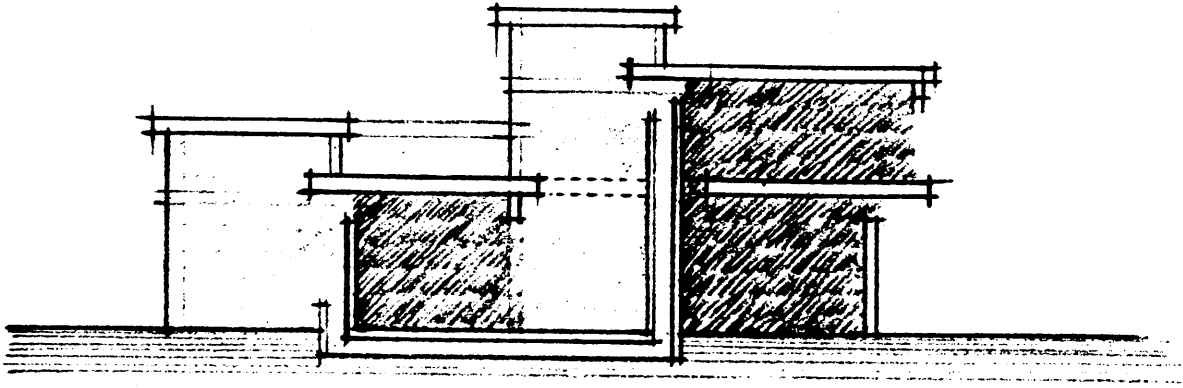

- light-form study of deep perimeter zone.
- section and plan schematic descriptions of formal interpenetration of: light-surface frame-containment.

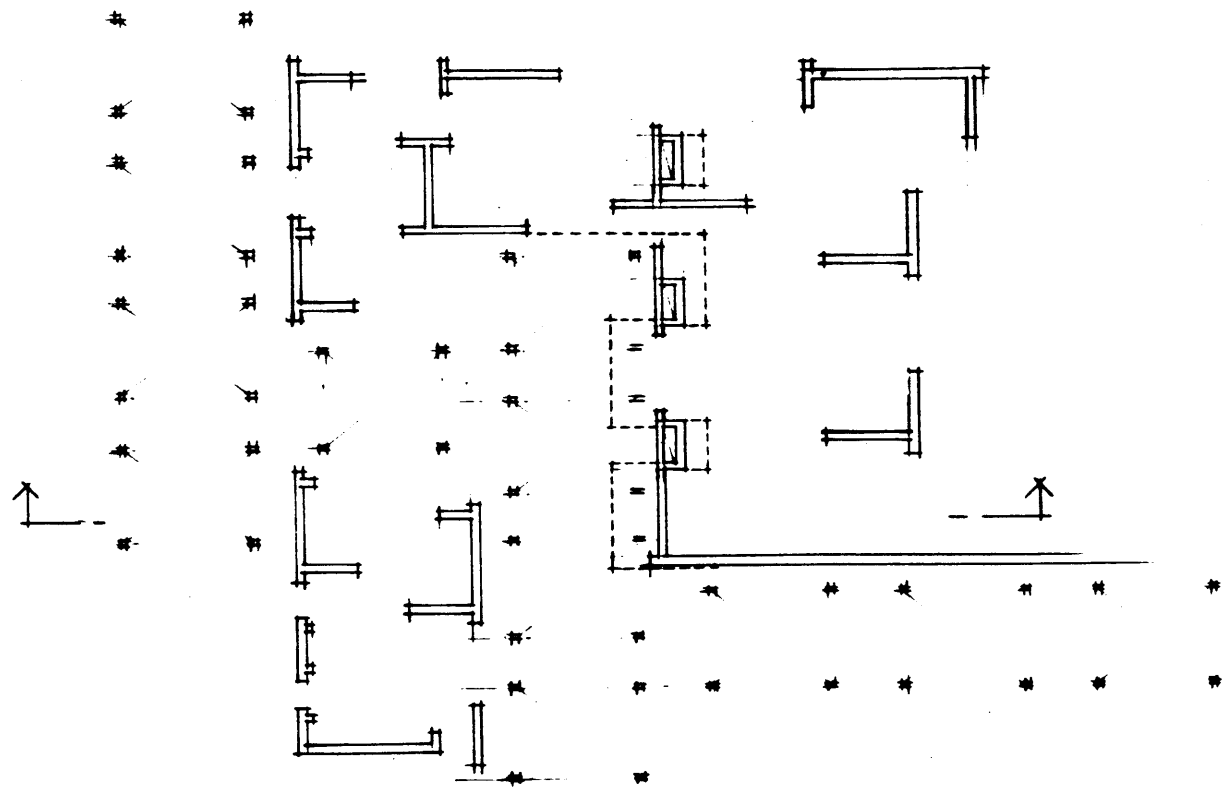
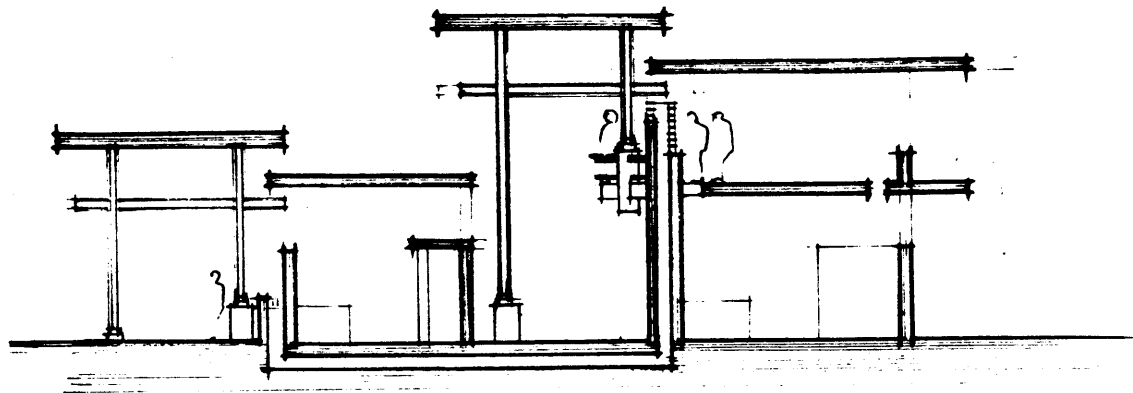

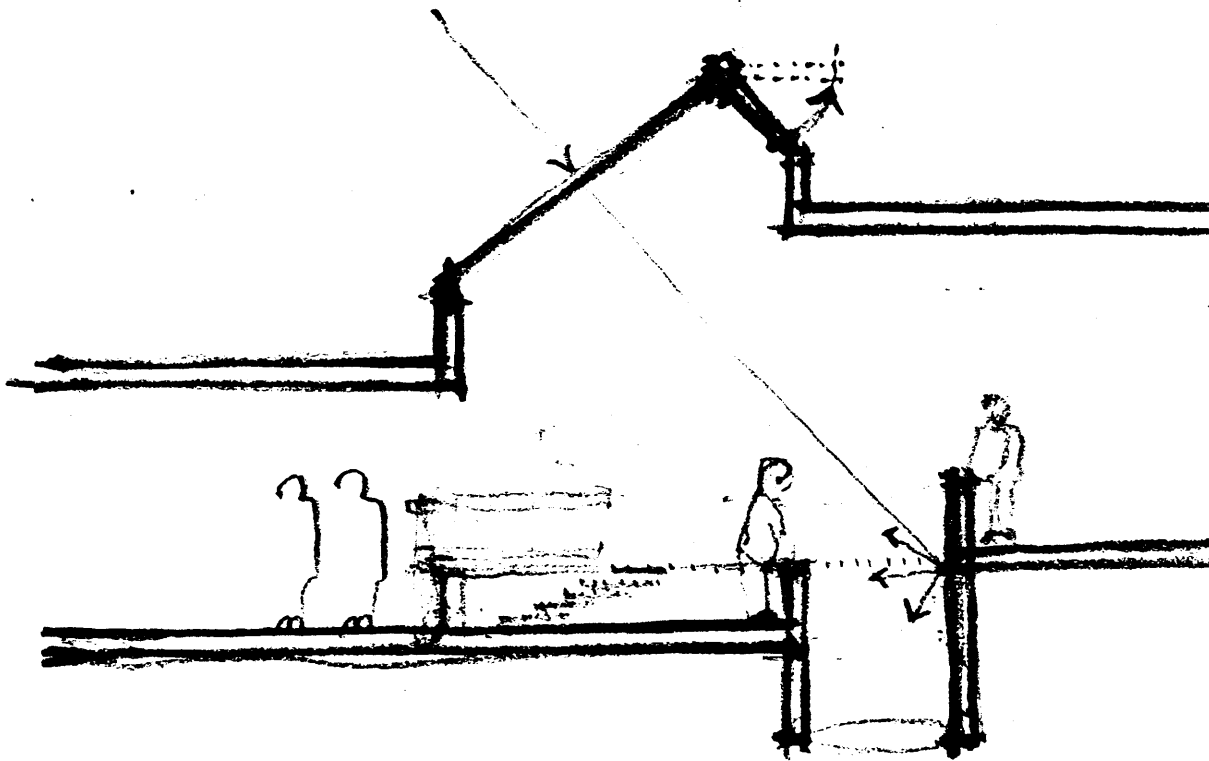

How does light penetrate the internal portion of a building?

? holes punched in the walls?

? shafts in the ceiling?

? mirrors?

Doesn't direct sun-energy deserve a better welcome?

-- let's receive it rather than strangle it or make it
fight its way through the building's skin.

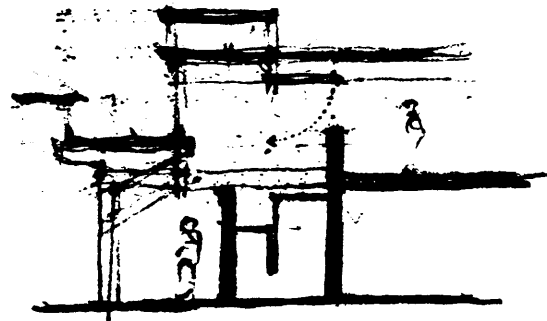
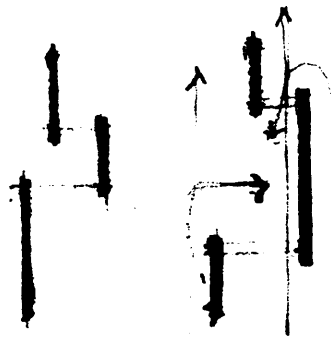
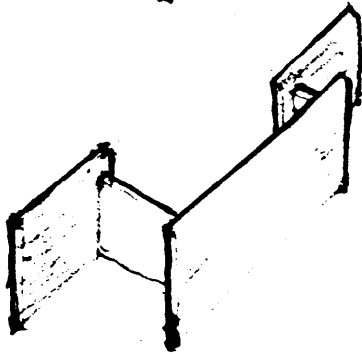
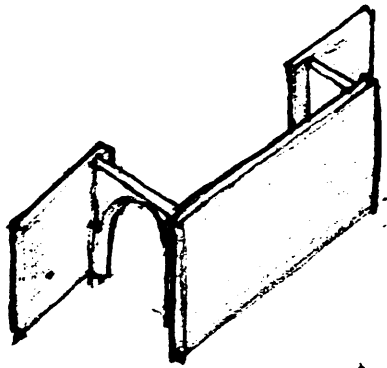

2407 13

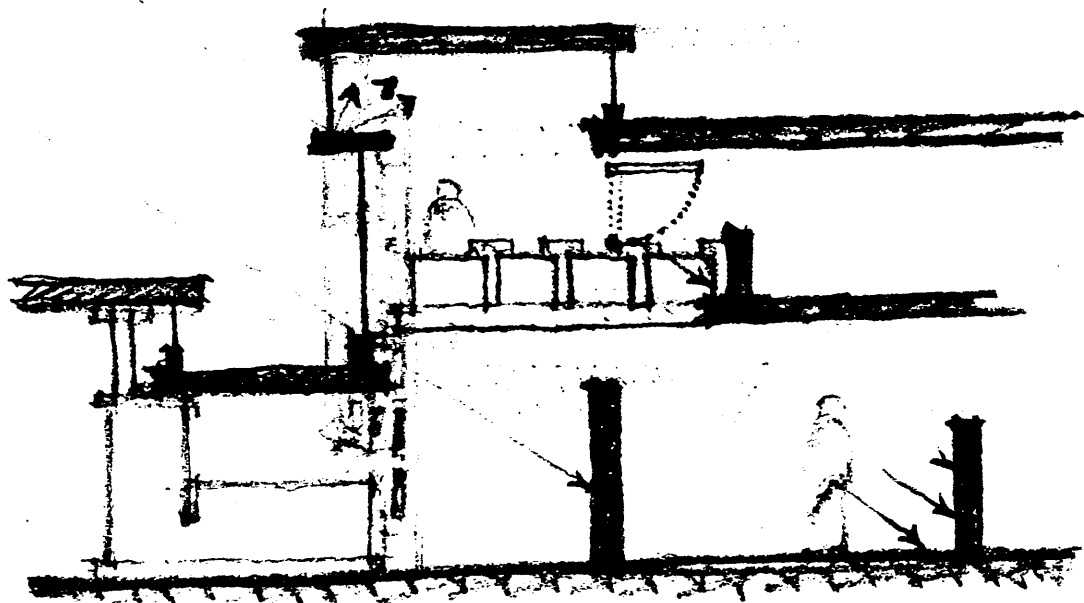

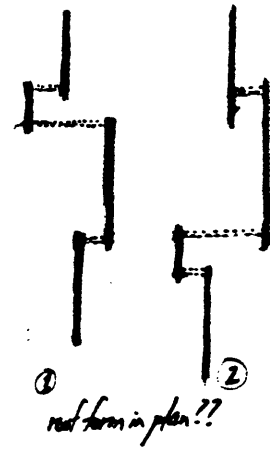
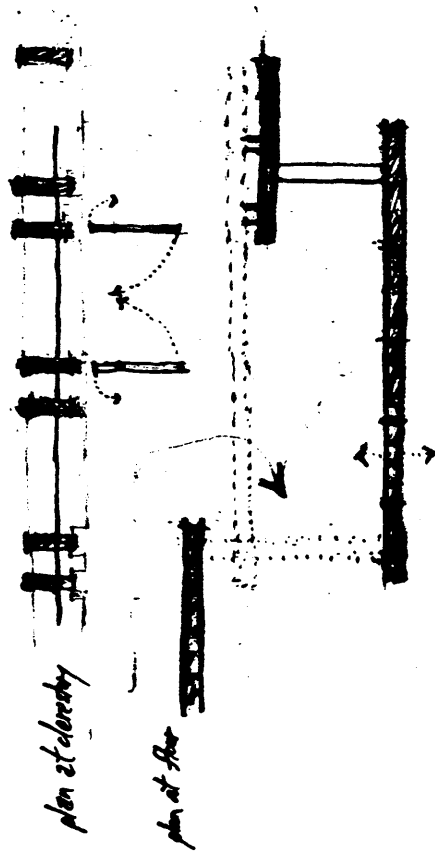
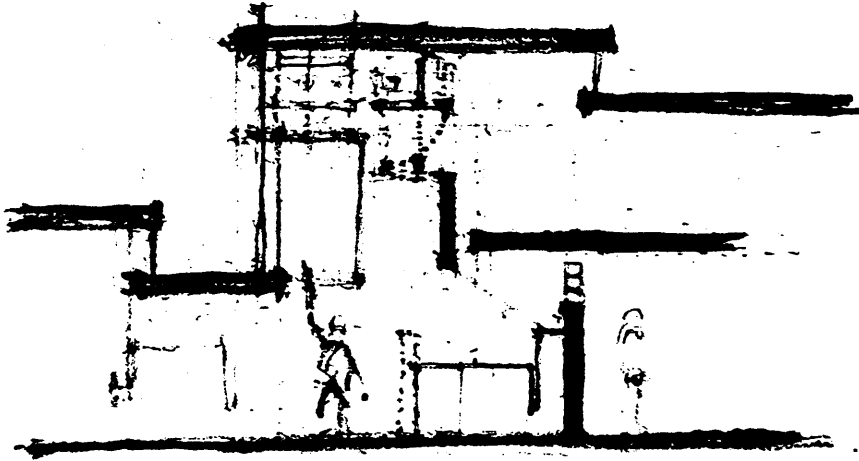

for your light has come...."

Isaiah 60:1

"Arise, shine,

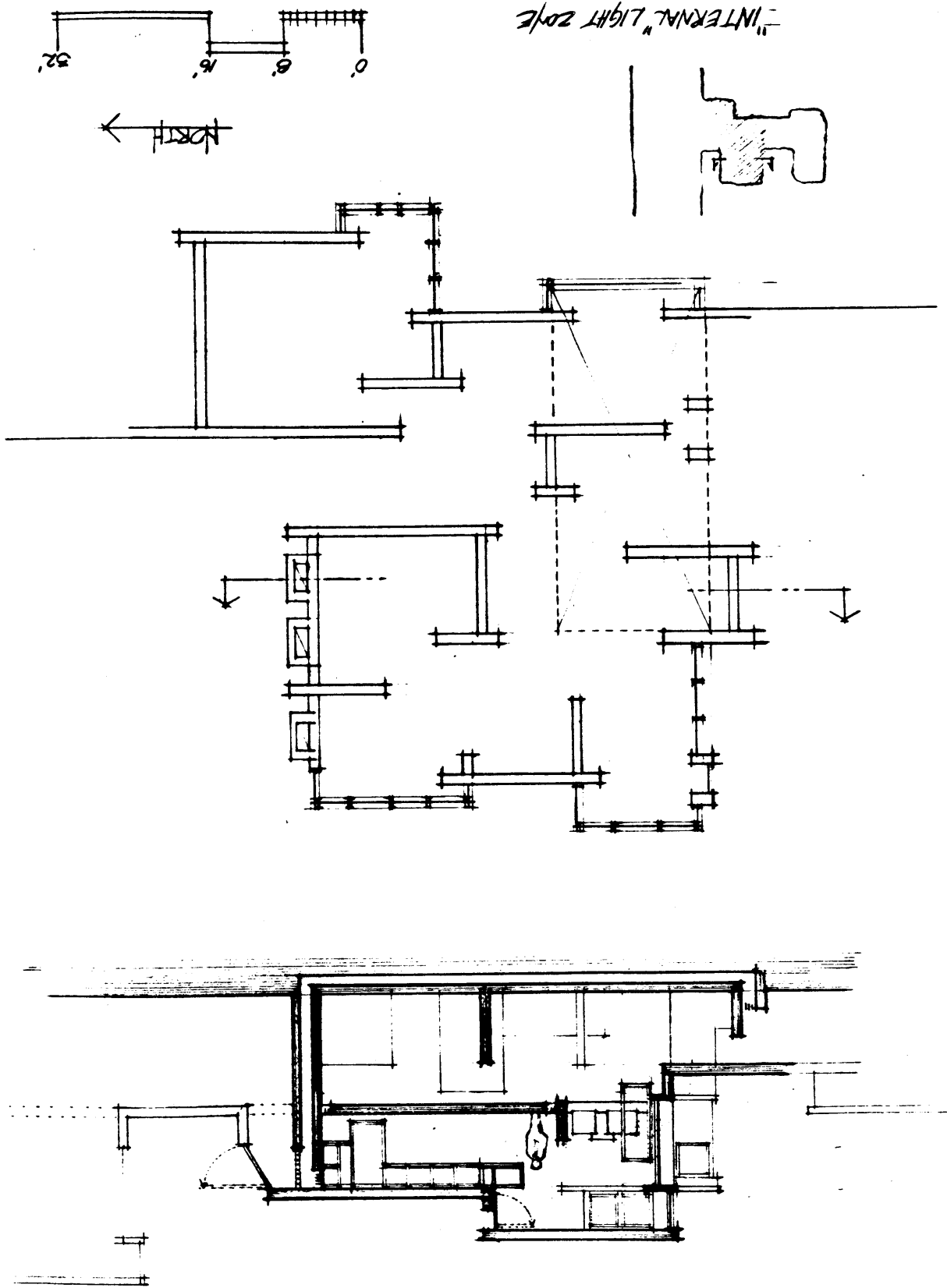

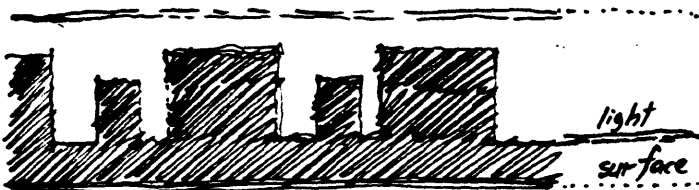
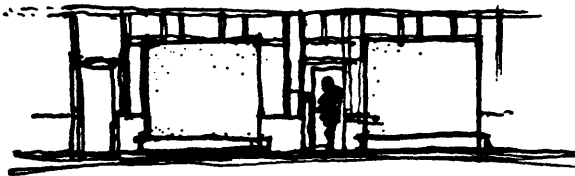
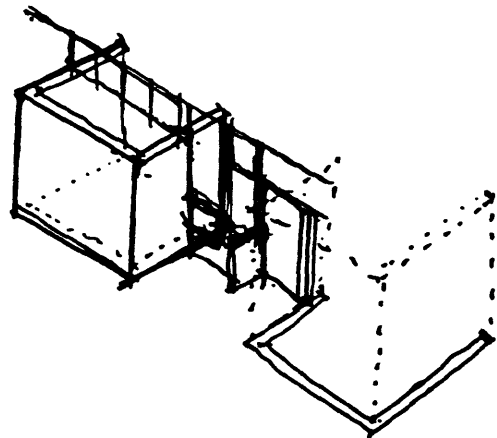
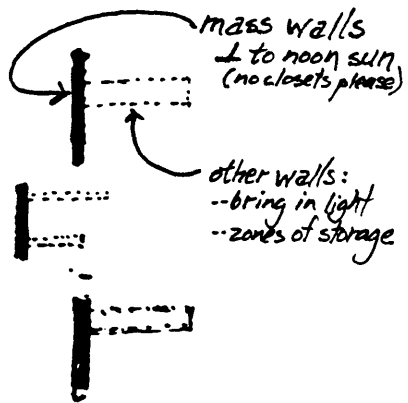
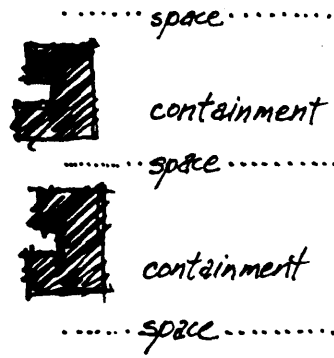
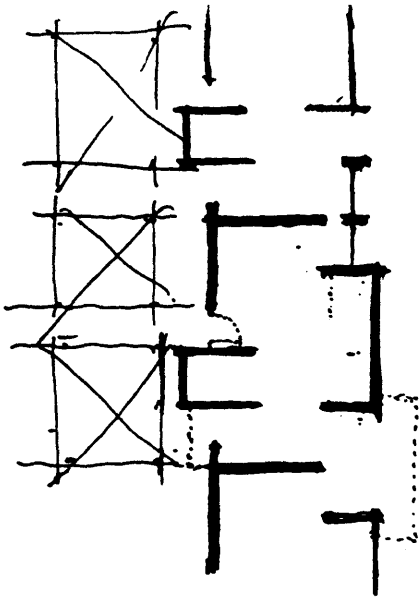

5. ASSOCIATIVE FORM OF LIGHT-DARK

some observations of light-form. . .

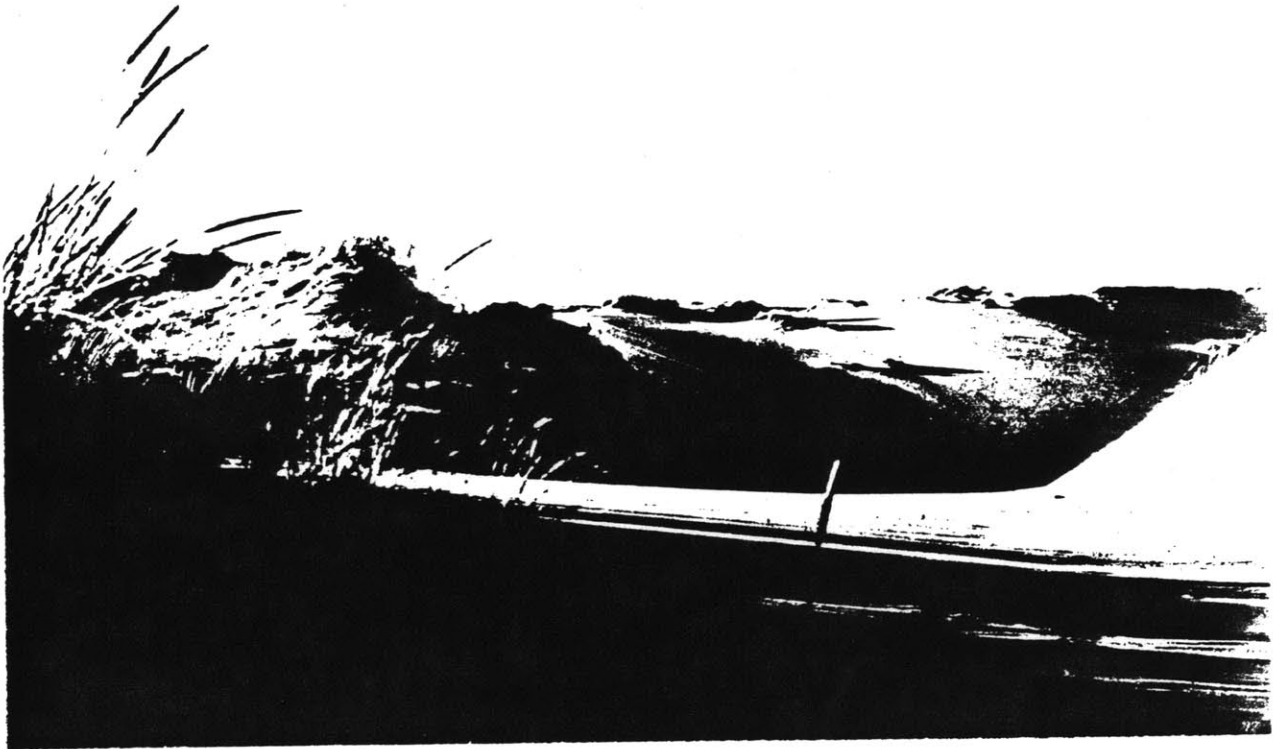

How do two of anything come together? Is there a straight line to define the meeting of the land and the sea?

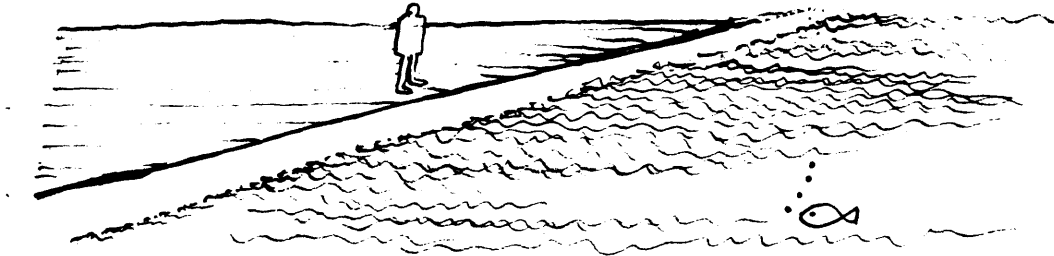

Okay, let's keep you two apart:

-- all the land on one side of the line.

-- all the sea on the other.

And no fair crossing over!

How do two of anything come together?

light - dark

sea - land

open - closed

sky - trees

man - woman

building - landscape

part - whole

inside - outside

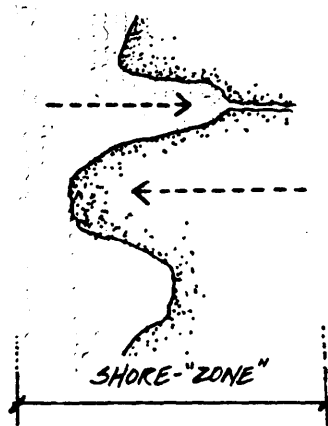

Since the shoreline is not a line at all but a "zone of exchange" between land and sea, how should this influence our thinking when we build surfaces in light? The reciprocal definition of land-sea should be a language that is transferable into our architectural vocabulary.

It seems -- no --

It is mandatory to see the similarities of how different groups of two come together. The similarities of union lend us an understanding of physical form and its related principles.

In Energy and Form, Ralph Knowles observes:

From the land, through the intertidal zone, finally to the water itself, this meeting place has some attributes of both worlds. It is a realm of two languages, one of the sea and one of the land; and there all life is, in some degree, bilingual. ...at the edge of a tide pool they are tiny variations reminiscent of the larger scale of the shoreline as a whole.³⁶

Similar bilingual communication between land and sea occurs at a range of sizes from the tiniest tide pool to the continental shelf. The shared definitions of water and earth are not limited to the "shore-zone"--they encompass a full range of 3-dimensional relationships:



Ecclesiastes 1:7

"All the rivers run into the sea;
yet the sea is not full.

Unto the place from whence the rivers come,
thither they return again."

Genesis 2:6

"...there went up a mist from the earth,
and watered the whole face of the ground."





When two events
systems come together,
substances
they share the zone in which they meet
by: sliding past one another
joining together in a relationship
exchanging territory in all three dimensions.



LIGHT-DARK ; TREES-SKY



ROCKS-SNOW

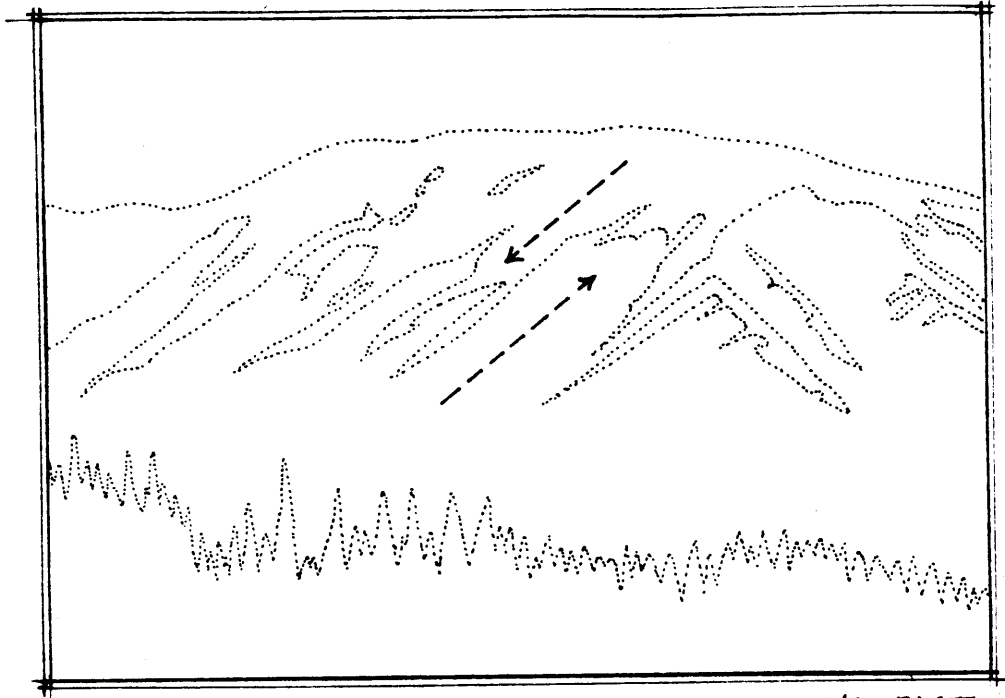

SLIDING PAST

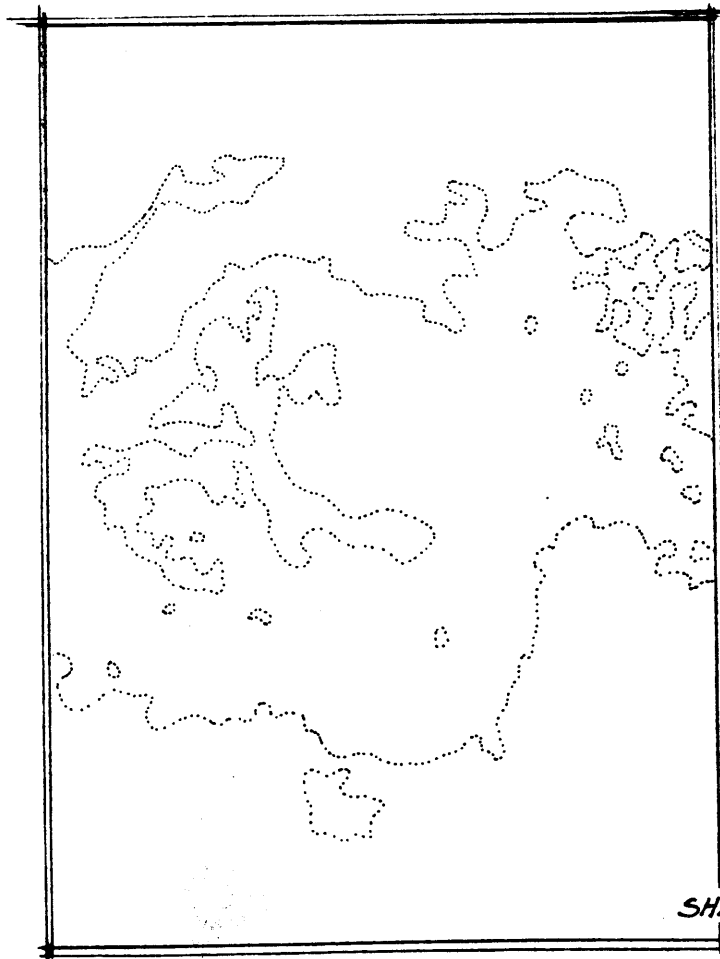

SHARING TERRITORY

Architecture—planning in general—breathes with great difficulty today. The breathing image epitomizes my conception of twinphenomena—we cannot breath one way—either in or out. I am concerned with twinphenomena, with unity and diversity, part and whole, small and large, many and few, simplicity and complexity, change and constancy, order and chaos, Individual and collective; with why they too are ignobly halved and the halves hollowed out; why they are withheld from opening the windows of the mind! As soon as they materialize into house or city their emptiness materializes into cruelty, for in such places everything is always too large and too small, too few and too many, too far and too near, too much and too little the same, too much and too little different. There is no question of right-size (by right-size I mean the right effect of size) and hence no question of human scale.

What has right-size is at the same time both large and small, few and many, near and far, simple and complex, open and closed; will furthermore always be both part and whole and embrace both unity and diversity. No, as conflicting polarities or false alternatives these abstract antonyms all carry the same evil: loss of identity and its attribute, monotony.

Right-size will flower as soon as the mild gears of reciprocity start working—in the climate of relativity; in the landscape of all twinphenomenon.

Van Eyck, 1959

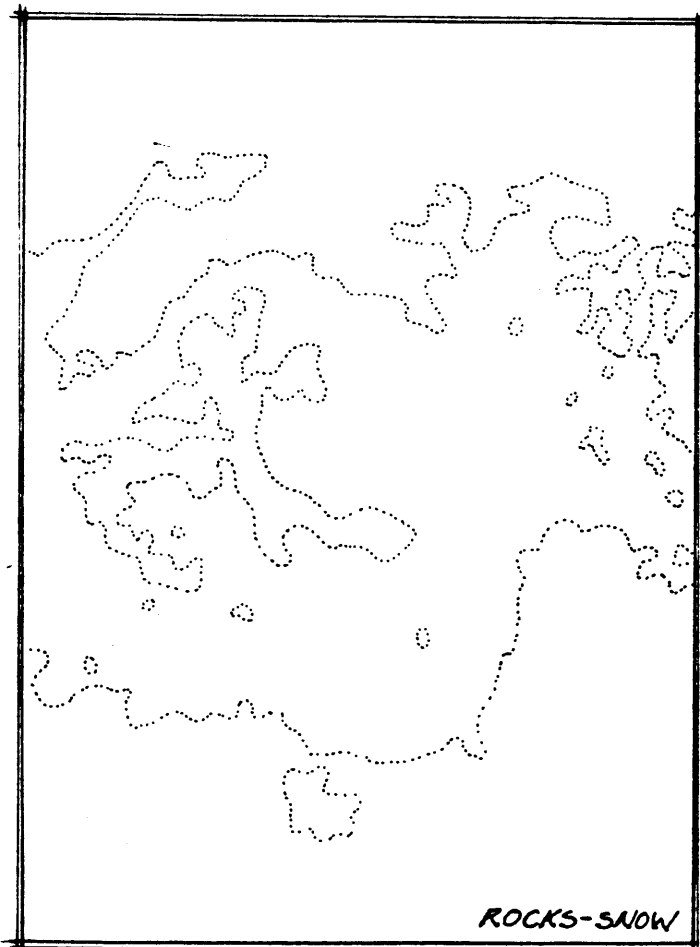

ROCKS-SNOW

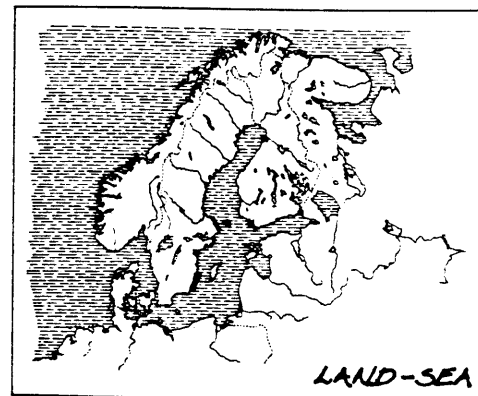

LAND-SEA

The joining together of
associative form of two elements
systems
substances

such as: sea - land
snow - rocks
light - dark

is readily seen and experienced in the vast
realm of the God-built landscape.

Shouldn't we then strive to find
build
experience
similar principles in the realm
of the man-built landscape?

? WHERE ARE THEY THOSE PLACES

how raised habitable is your 'favourite'
? associable are 'natural'
inclusive man-made place(s)

why do you like to be at that
? want (those)
particular

how high does your coast(s)
? low our village(s) when
school rate. country(s)
house apartment
office city(s)
'environment'



By examining the life of a simple agrarian structure from pre-birth to decay, we can begin to see a portion of the range of associations that exist between the God-built and the man-built. During which phase(s) of this structure's life does the building and its surroundings share the greatest associations?

THE SITE: where the forest meets the field.

An undisturbed landscape of trees, undergrowth, and grasses that filter, absorb, and reflect the light as it streams to the grassy earth. The landscape is rich with potential building materials: trees, sod, earth, minerals, rocks, etc. In this three-dimensional world, every element inhabits its own particular territory.

The structure is to inhabit this edge between the field and the forest. It will be built with materials from the forest. It will serve to store tools that will be used in the field. Thus, elements from one zone--the forest--will be used to contain elements from the other zone--the field.

There is, in a spatial sense, a marriage between these two zones at the edge which they share. The materials have come from the forest and the earth: support timbers, board siding, iron nails, tin sheets. The materials are transformed bits of the landscape currently divorced from their previous task and awaiting their new one.



ASSEMBLAGE: the process of making.

Stick by stick, the place is built. Following the foundation, or foot, the frame is assembled of vertical, horizontal, and diagonal members. The dimensions between support members appears to correspond to the dimensions between trees in the forest beyond. This provides the hewn timbers with a strong--though momentary -- relationship with their previous occupation.

The board siding then coats the frame with a vertical surface and the tin sheets cap the structure. The frame is hidden now by the new surfaces, virtually divorcing its associative marriage with the frame-like qualities of the forest while transforming it to the surface-like qualities of earth and sky.

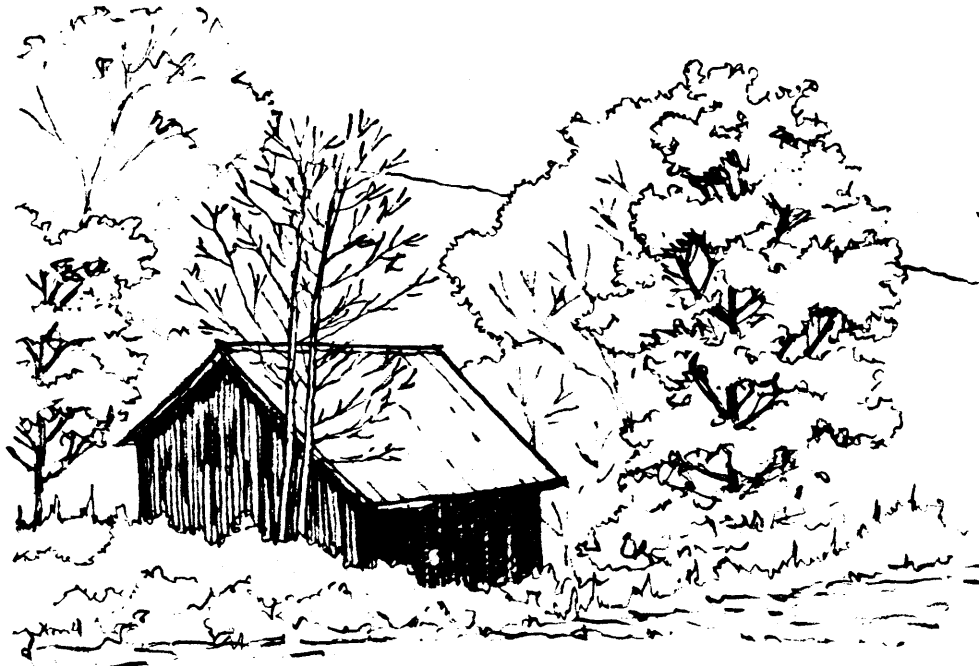

USAGE: adaptation and transformation.

The materials weather and adapt to their new occupation:

The board siding darkens and assumes a new associative role-- relating now to shadows in the woods and dark gray cliffs. The tin roof shines brightly in the light, associating directly with the sky.

Each material has shifted from its original territorial boundaries:

Wood siding from the forest cliff and shadow.

Tin sheets from the earth become sky.

The relationships have changed; the origins obscured.

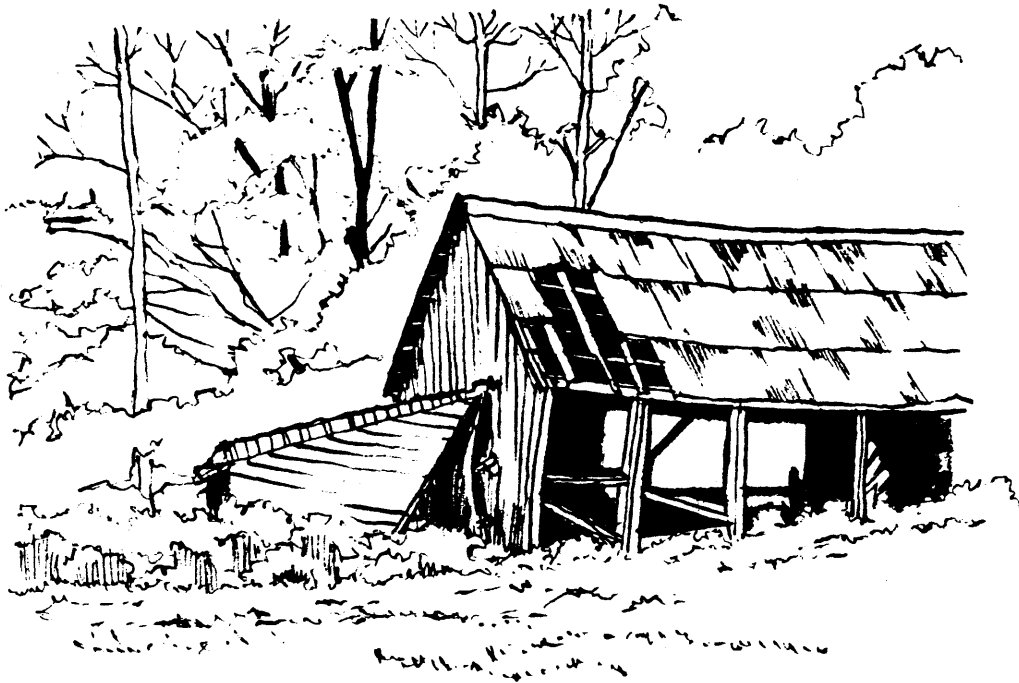

DECAY: quality of a ruin.

As decay sets in and the building returns to the earth from where it came, the range of associations it exhibits becomes abundant. Missing pieces and splintered parts reveal the frame once more, reminding us of how it was built and recalling its direct relationship with the screen-like quality of the forest. As the tin cap rusts, its dialogue with the sky subsides while it again becomes like the earth and the autumn foliage.

The building and its surroundings
.....
The man-built and the God-built

share more of each other's characteristics during this stage of the building's life than during any other stage.

The building is "containing" the landscape, in part, as light and vegetation work their way into the structure. The landscape reciprocates by containing bits of the building as materials disassemble themselves and come to rest in the site. The spacing of the exposed uprights echo the dimensions between trees. Some of the posts are in light, others in shadow, while the tree trunks exhibit this reversal as well. The frame is more dense above; assembled of smaller and more numerous pieces much like the branch canopies of the forest.



The quality of a ruin is not to be understated--
it lives a life rich in association:

building - landscape.

man-built - God-built.

This rich range and innate connection should be a major contributor to our understanding of the physical world.

Maurice

Smith notes that:

The initial designing is only a little part of it, the building has its life to live, just as people do. You might just as well abandon your children "complete" at birth. There's a continuing process of growth and change. We're not making fine art objects to display in fashionable galleries; we're helping worlds of definition into existence...³⁷

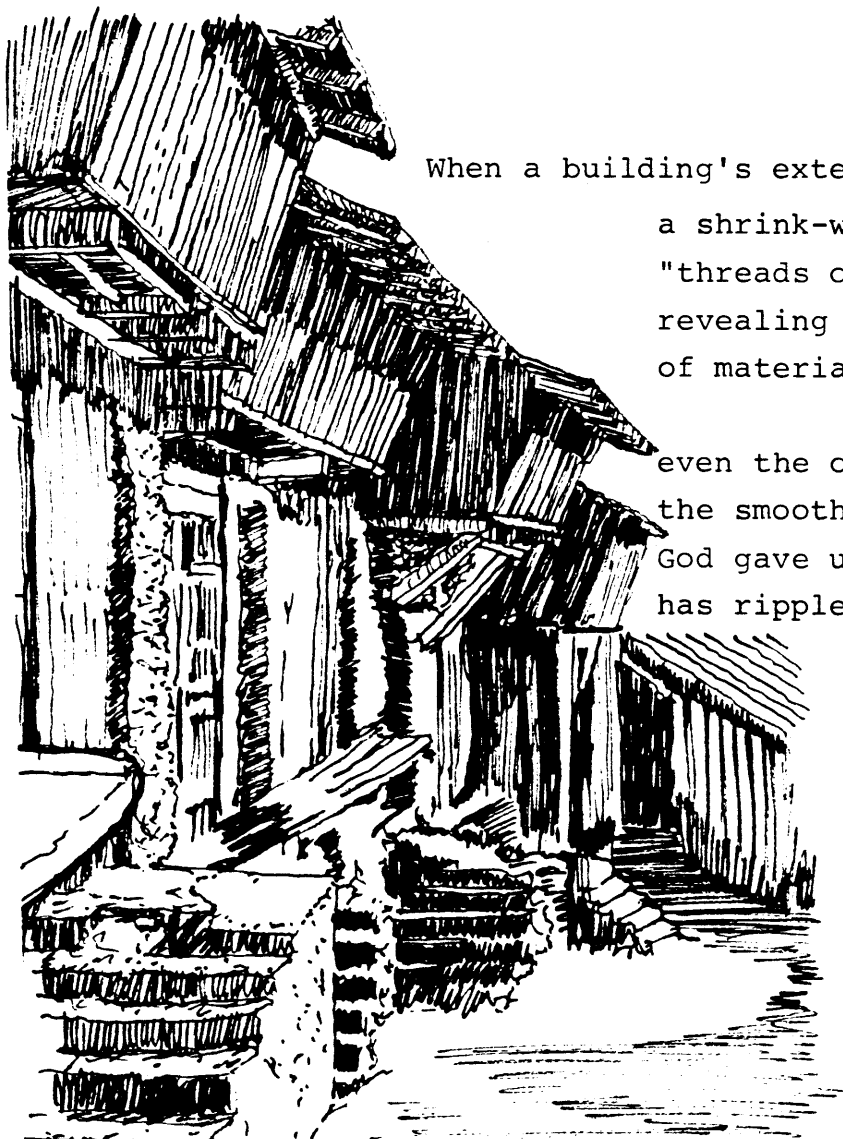

When a building's exterior surface is not
a shrink-wrapped facade...
"threads of light" appear,
revealing the grain & texture
of materials.

even the ocean --
the smoothest surface that
God gave us --
has ripples reflecting light.



a direct growth from the ground is not always possible
-- but the principle of that growth is...
the ground-like materials must work their way up
-- to exchange with the sky-light...

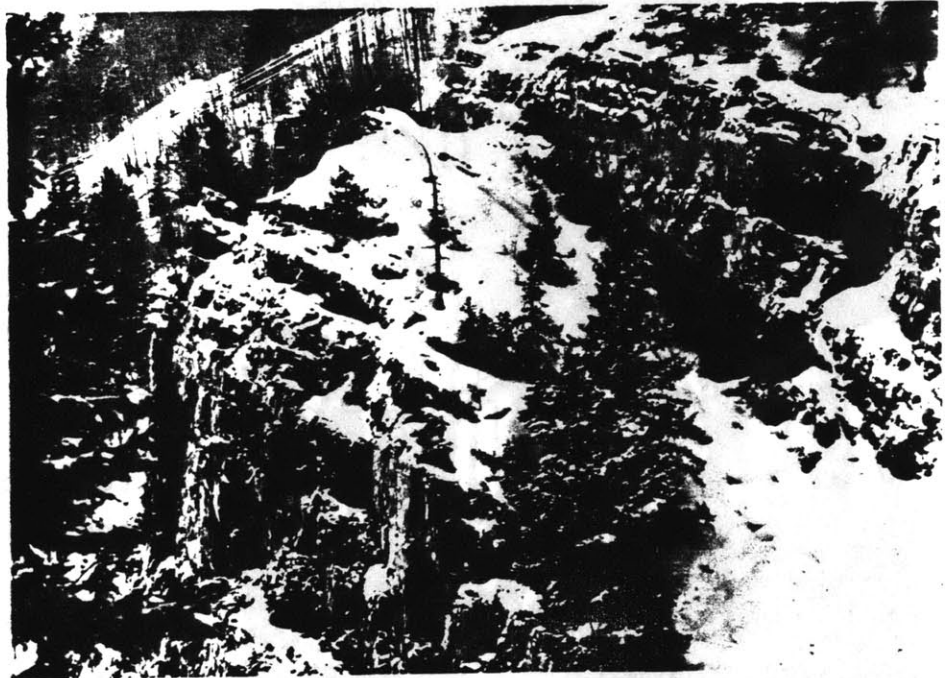

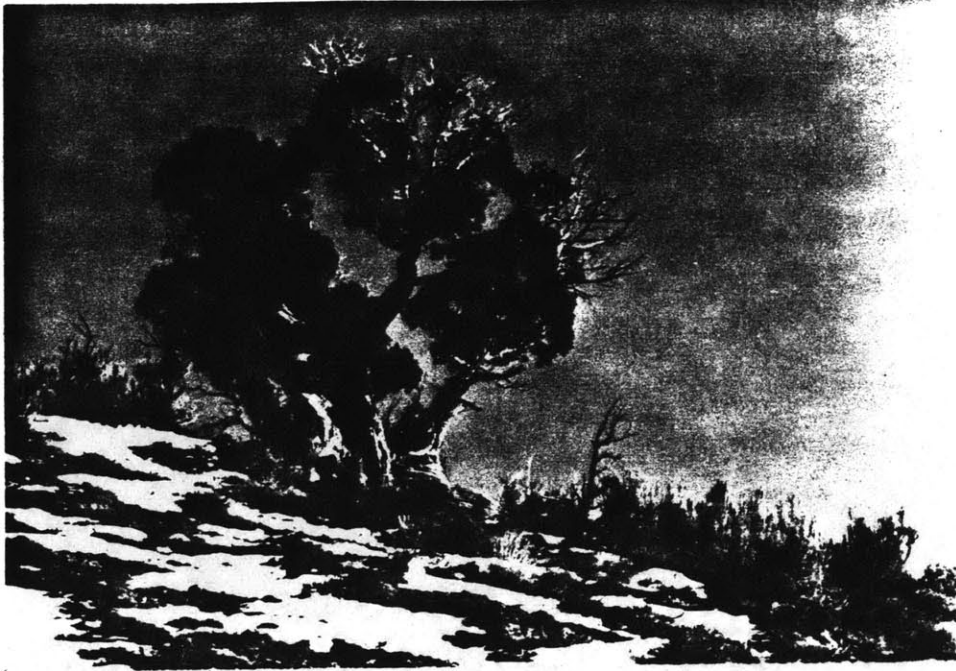

"building" space &
"letting" light...

-- reciprocate with
the solid parts --

fills a place...
with space!



Why do skiers love the stuff called powder snow?

because we penetrate the surface
 get into the light
 build the zone of exchange

between skier & snow--frame & surface.



whether

trees or columns
acres or arcades...



light exists alternately with dark...

sun - shade

space - tree

open - closed

space - column...

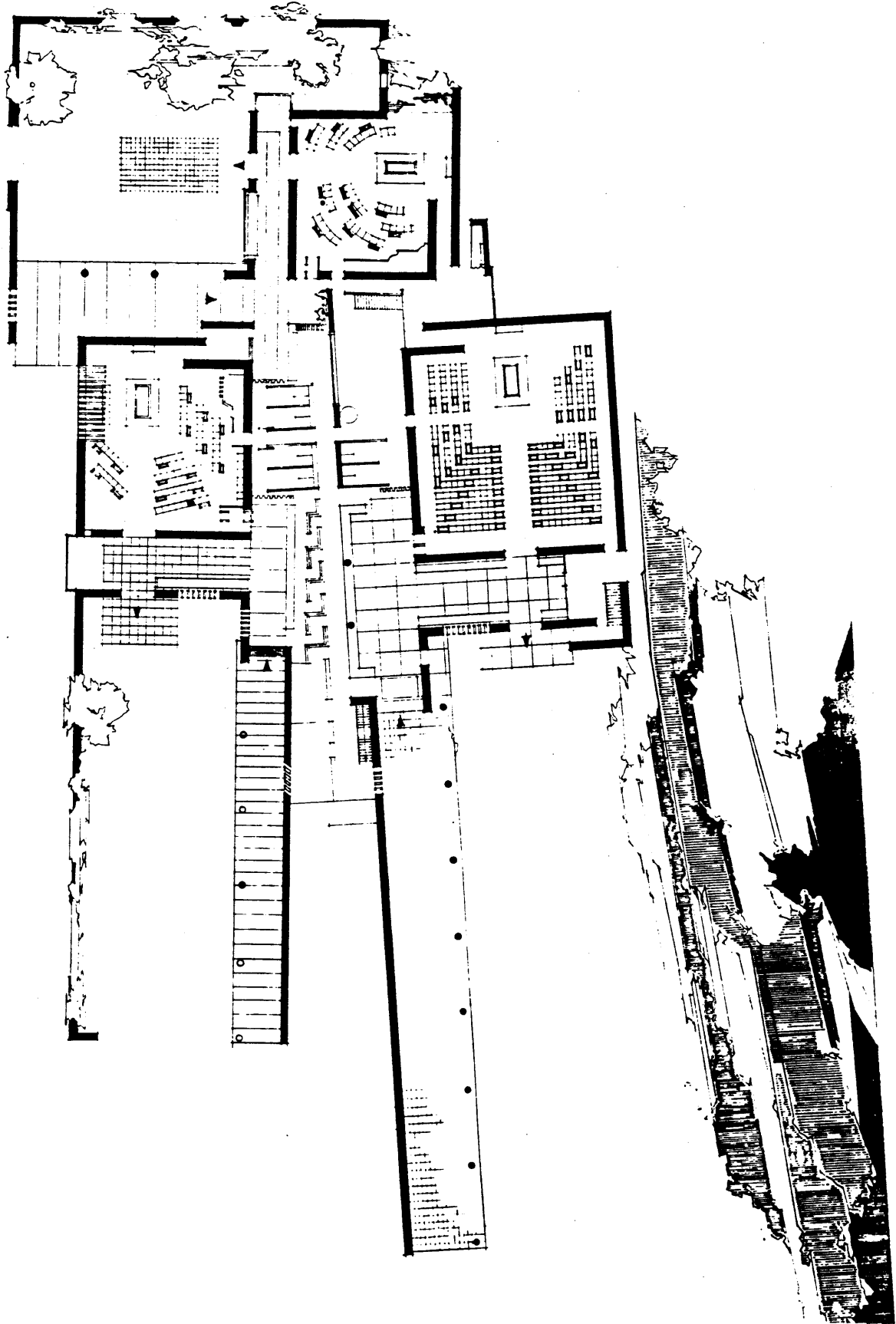



building containments
 solids
 rocks
 privacies

that are separate
 self-stable
 territories

allows the light - space
 public - access
 movement - water
to live in the in-between...



... so, what about the exchange(s)
in the man-built world

between opening and closure
light and surface
window and wall?

... how do they
can
should they:

1. join together in a relationship?
2. connect in the mind?

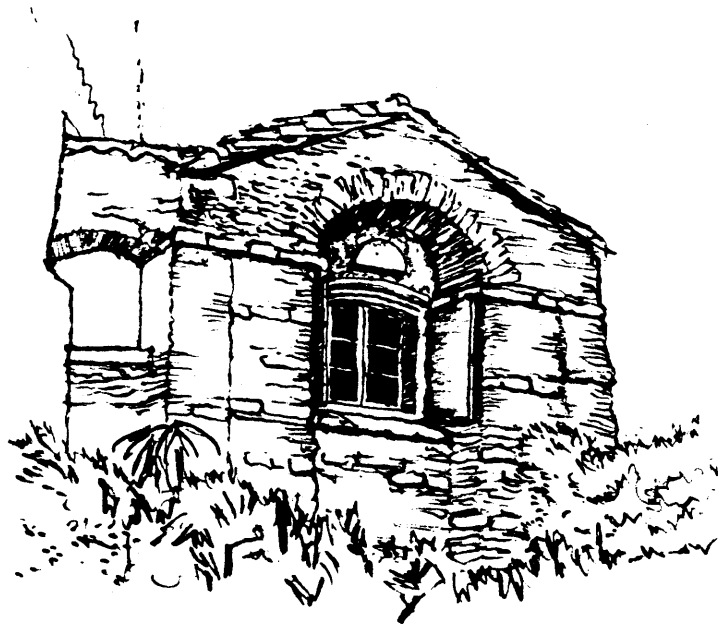

The window shown above in the D. L. James residence by Charles Greene is much more than a punched opening in a wall:

- the glass is in a different plane than the mass:
it is set deep into the wall.
- the stone coarsing at the springing of the arch is
interrupted by the opening and displaced to the sill.



~~...thus integrating the opening with~~
the surface in a spatial exchange.

...this simple displacement gives
the window a life of its own with
and in the wall.

- the two are accepting one another graciously.
- even the shutter is given its own place to inhabit.

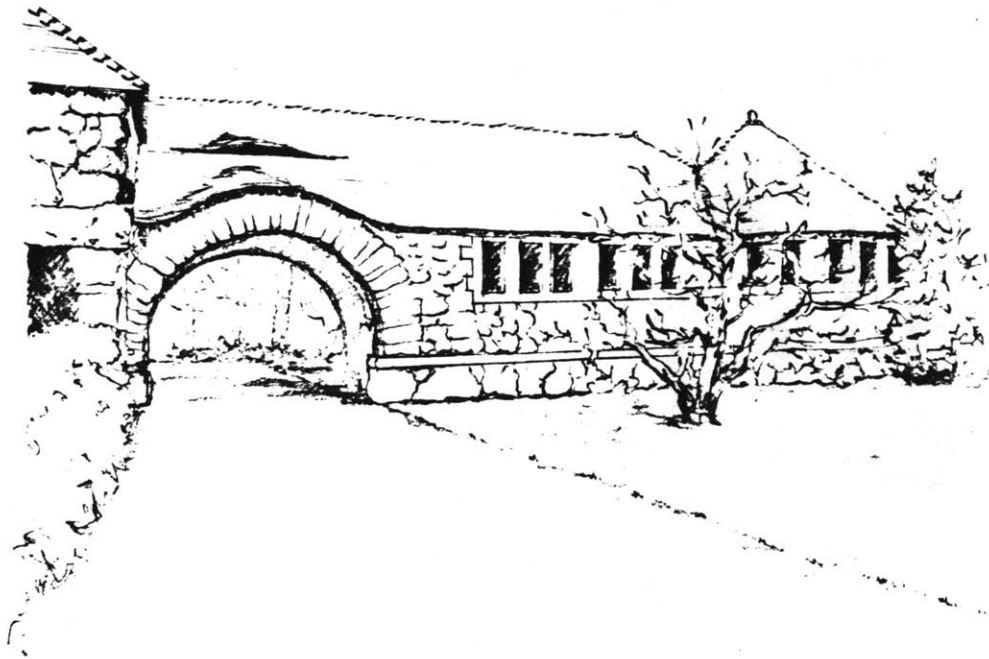

The opening through the Ames Gate Lodge by Richardson directly influences the surface of the roof:

- the eave line is lifted up by the arch below, thereby reinforcing the existence of the opening.
- further up the roof, the surface cracks into an eyelid dormer for an additional formal response to the opening, building a zone of exchange.

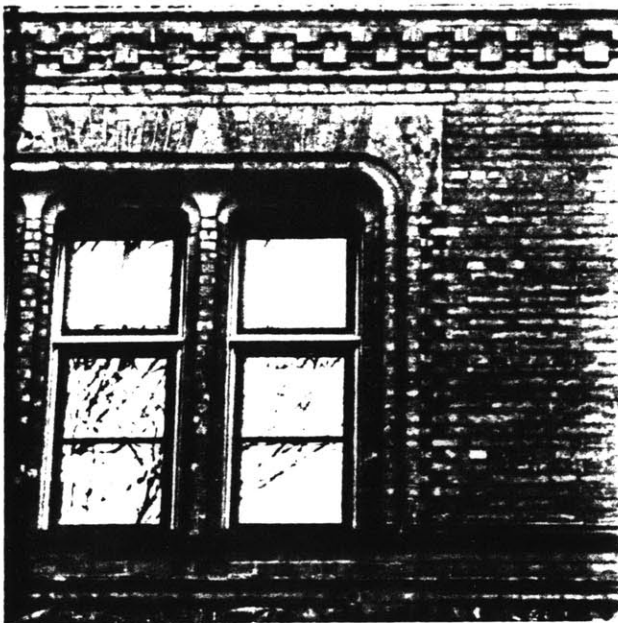

Even a minimal gesture can acknowledge the arrival of the opening within the surface.

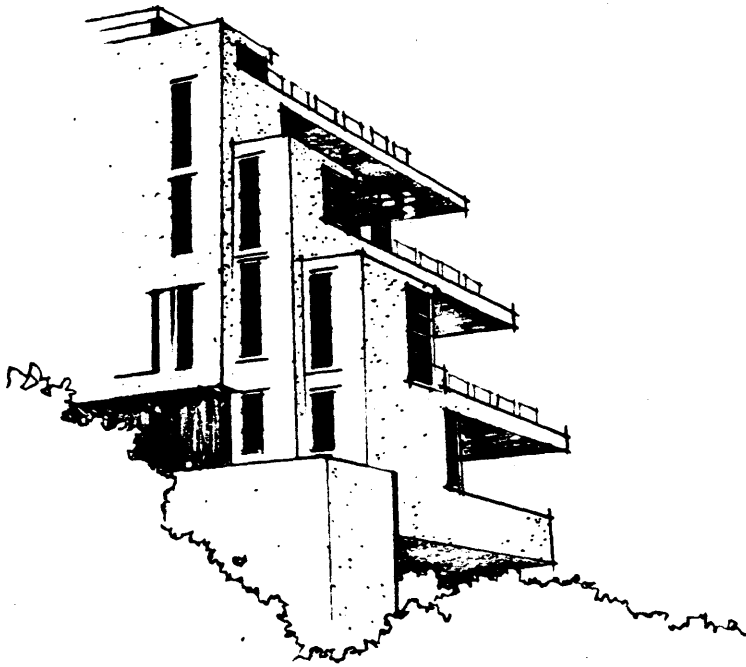

R. M. Schindler, in the Wolfe house, embraces the window with the surface:

- the form of the surface provides the place for the opening.

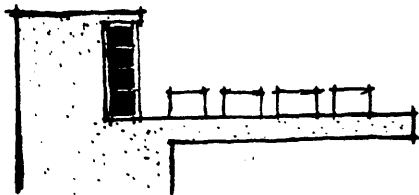

- the reaching, stretching surface of the balconies further reinforces the event of incoming light.
- the railing, a similar dimension as the window unit, marches out from inside to light while providing yet another layer of association.



Since light...physical and spiritual...comes from on high--
the form of the opening is perfectly justified in reinforcing
this fact.

The wall surface can
penetrate the roof and

"reach for the sky"

Thus giving the opening
a real place to be.



ISAAC FLAGG HOUSE II; Berkeley, California. 1912. Bernard Maybeck

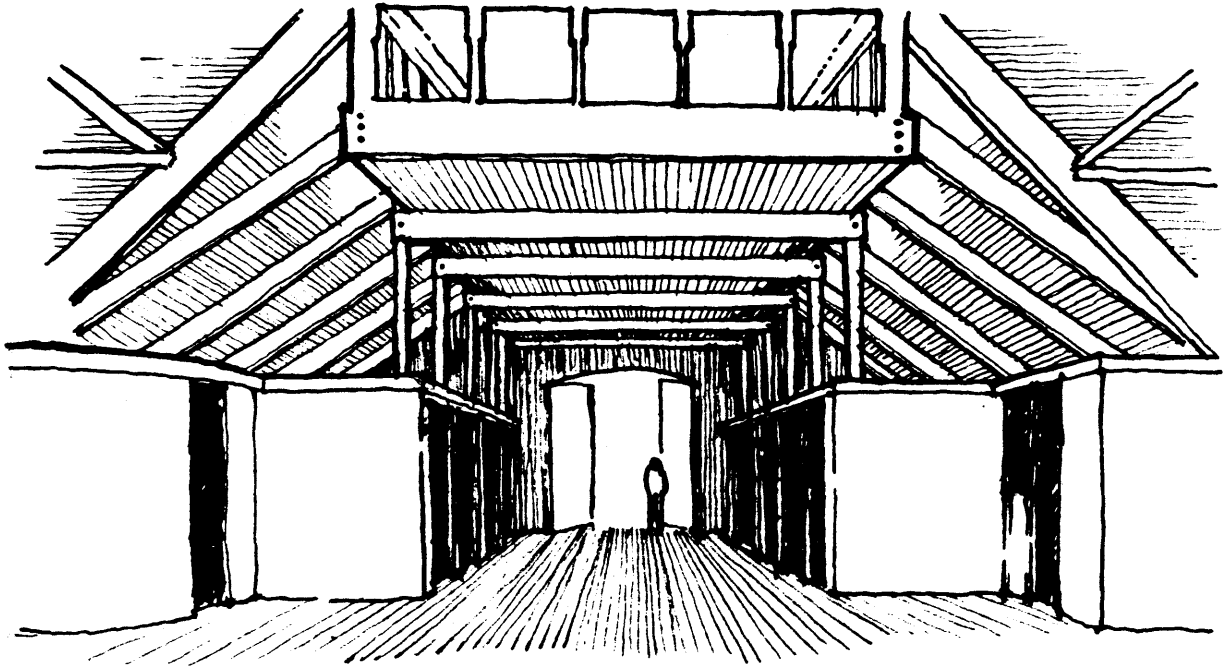

If one is going to work with a full range of form, why not build a

"room for the light"

effectively receiving the outdoors and giving the light a real sense of belonging.

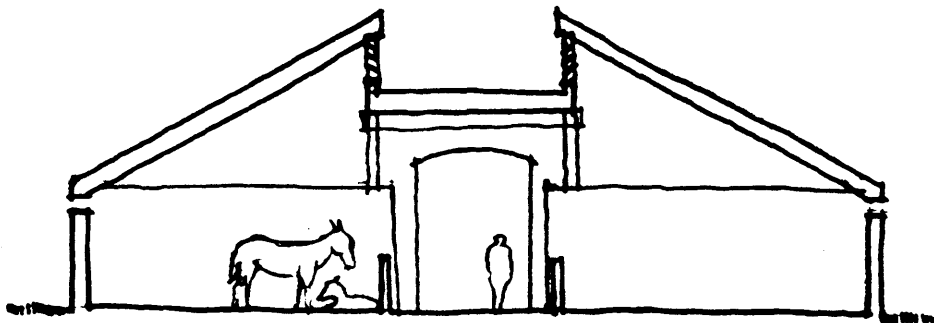

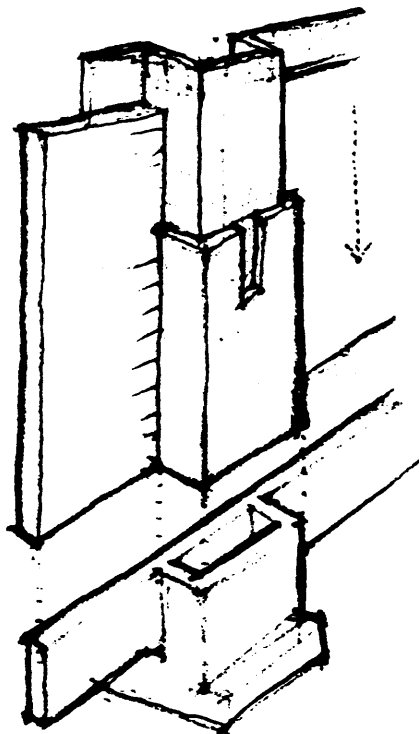
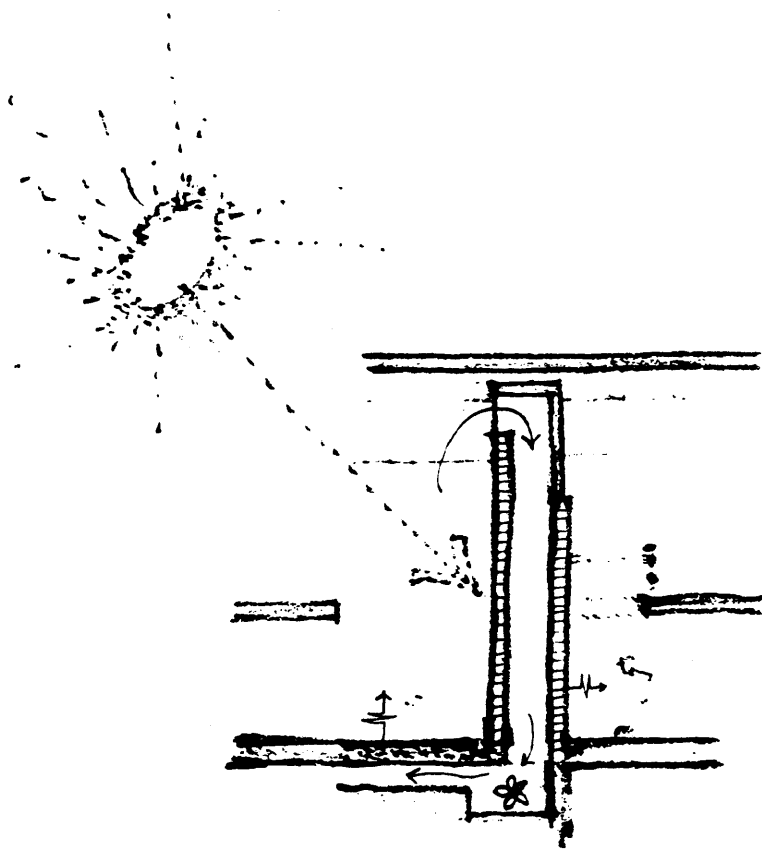

...and when the light
becomes heat...

pull
it
down
and through
the surfaces...

letting the form of
light & mass
continue to exist
in 3-D reciprocal
definition.

6. EPILOGUE

a beginning...



thesis - degree
research - shelf?

...this thesis is not an end in itself, but an active
beginning...

education - profession
learning - working
ideas - actions
believing - doing

...if ideas are not built into actions, they
become wasted time/spent energy with
no returns.

James, a servant of God, wrote:

Do not merely listen to the word, and so
deceive yourselves. Do what it says.
Anyone who listens to the word but does
not do what it says is like a man who looks
at his face in a mirror and, after looking
at himself, goes away and immediately forgets
what he looks like.³⁸

...and so it is.

...this thesis hopes to define a zone of thought-action
beyond the boundaries of these pages...

...an active beginning as opposed to signed, sealed,
and forgotten...

...the intent of this thesis is to:

- build your appreciation for the many dimensions of light...
- make you think twice about extruding another solar section...
- help you to see the boundless wealth of the God-built...

These final pages show a proposal for a chapel/auditorium. This is a study which begins to put into action some of these facts of LIGHT-FORM.

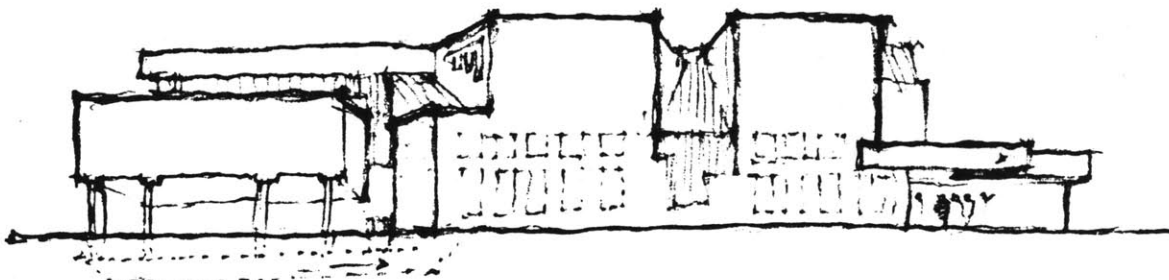

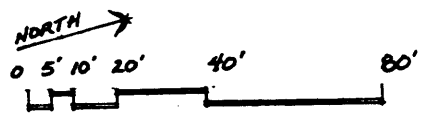
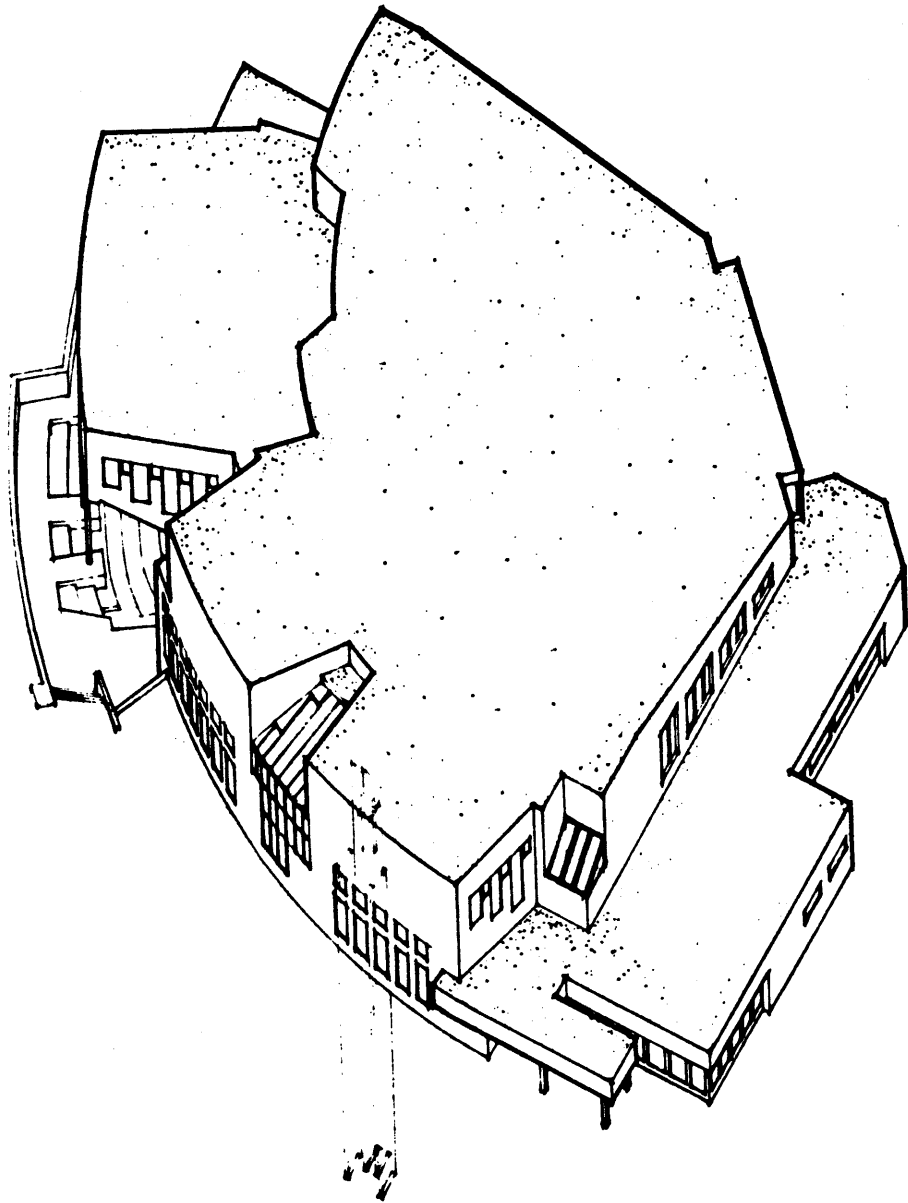



SNOW-ROCKS



LIGHT-FORM

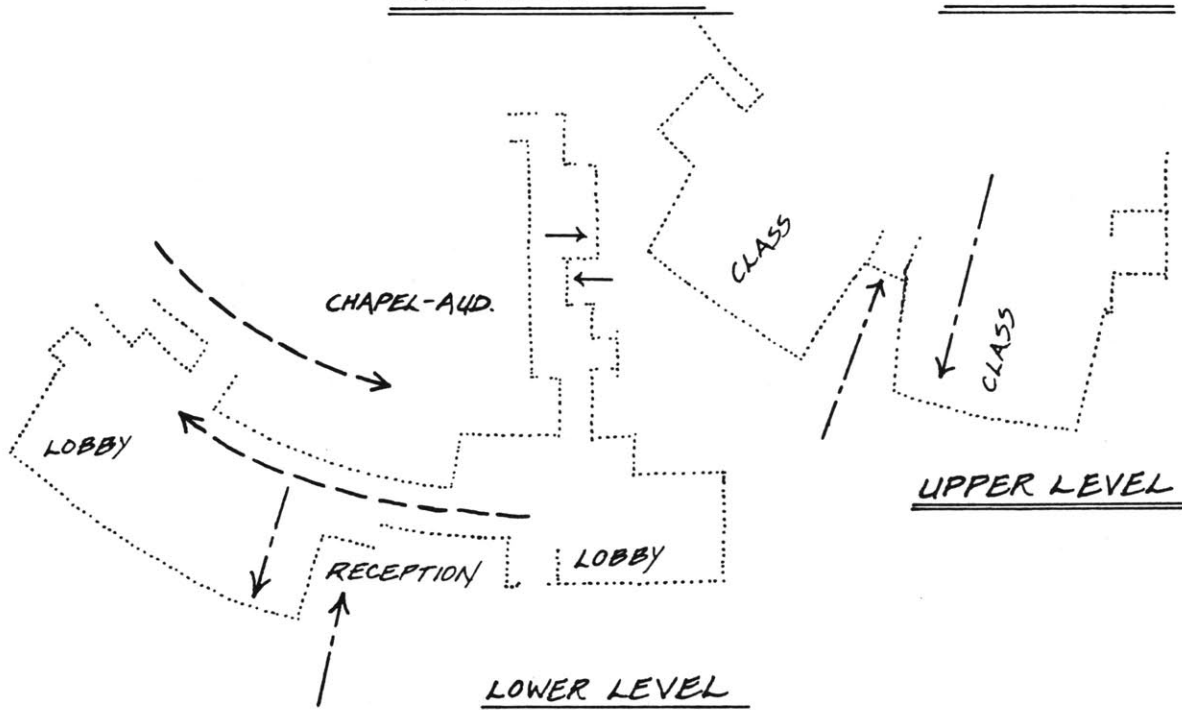

LOWER LEVEL

UPPER LEVEL

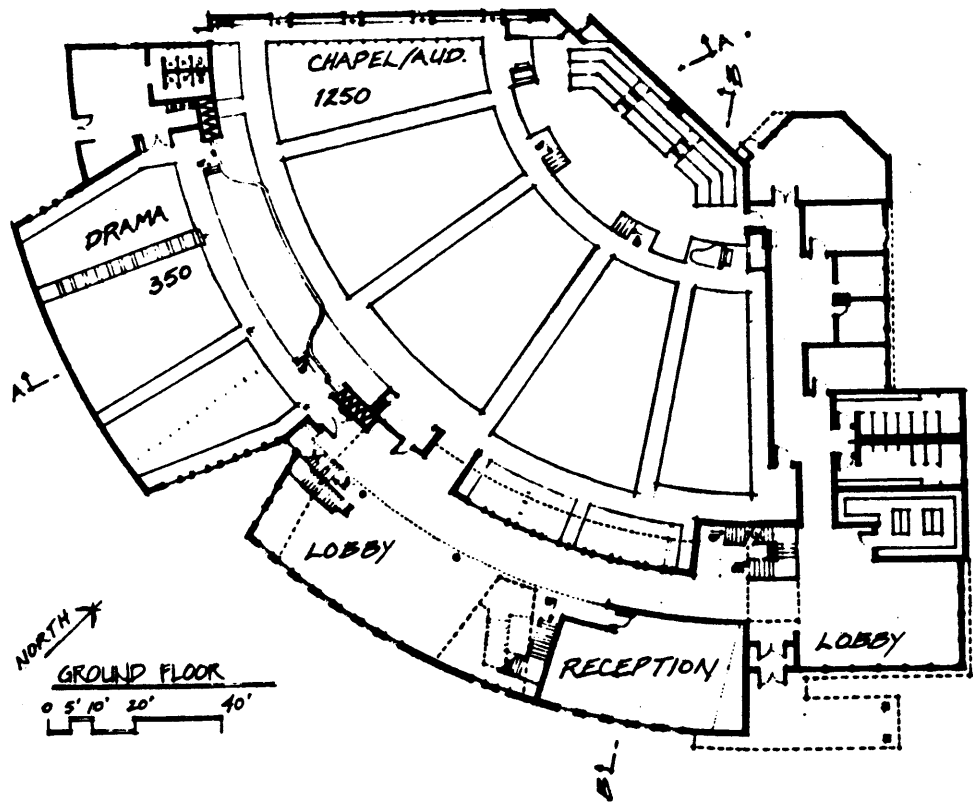
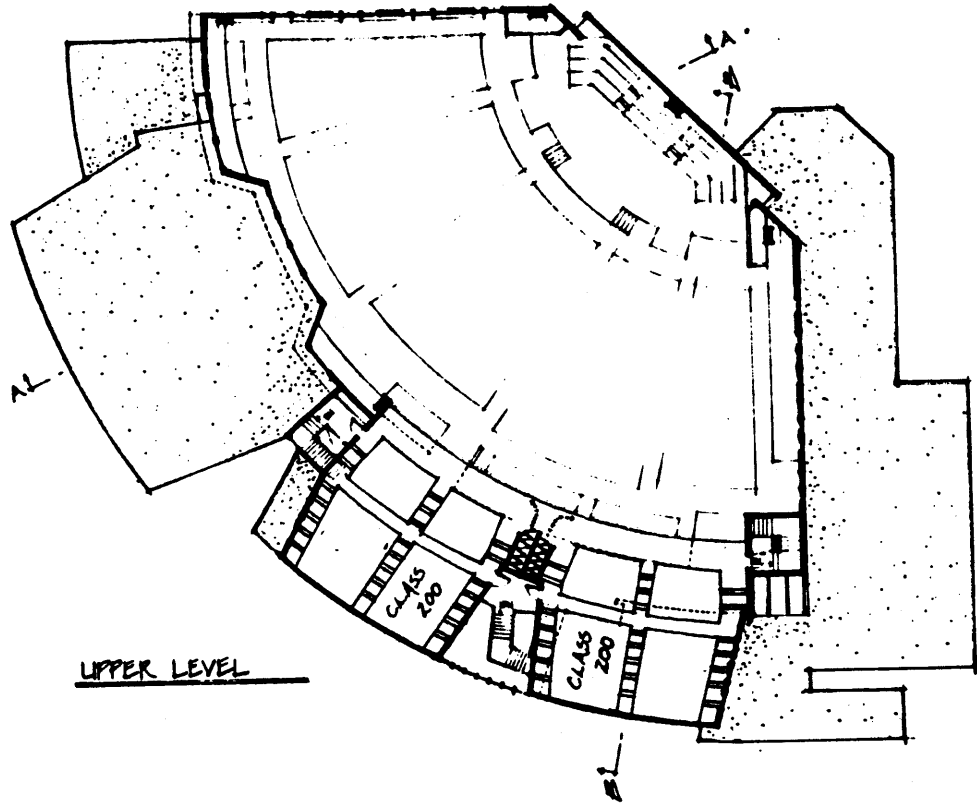

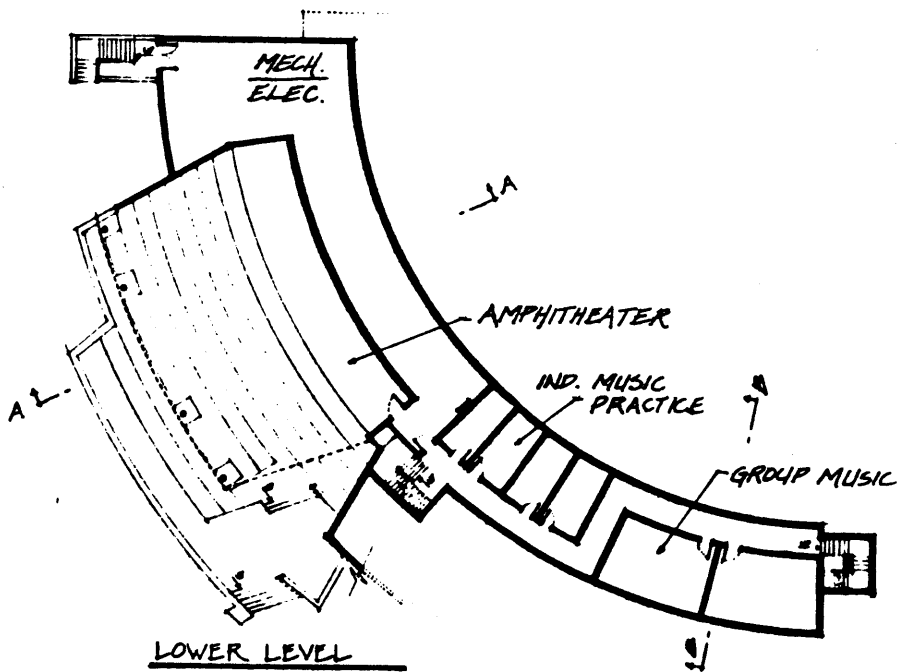
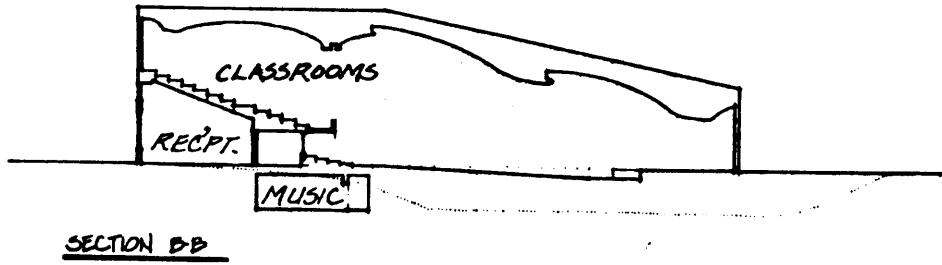
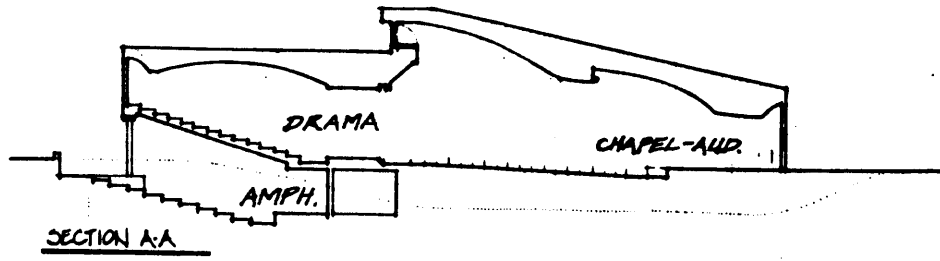

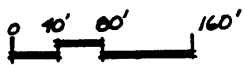

**PROPOSED CHAPEL
AUDITORIUM**
2000 SEATS

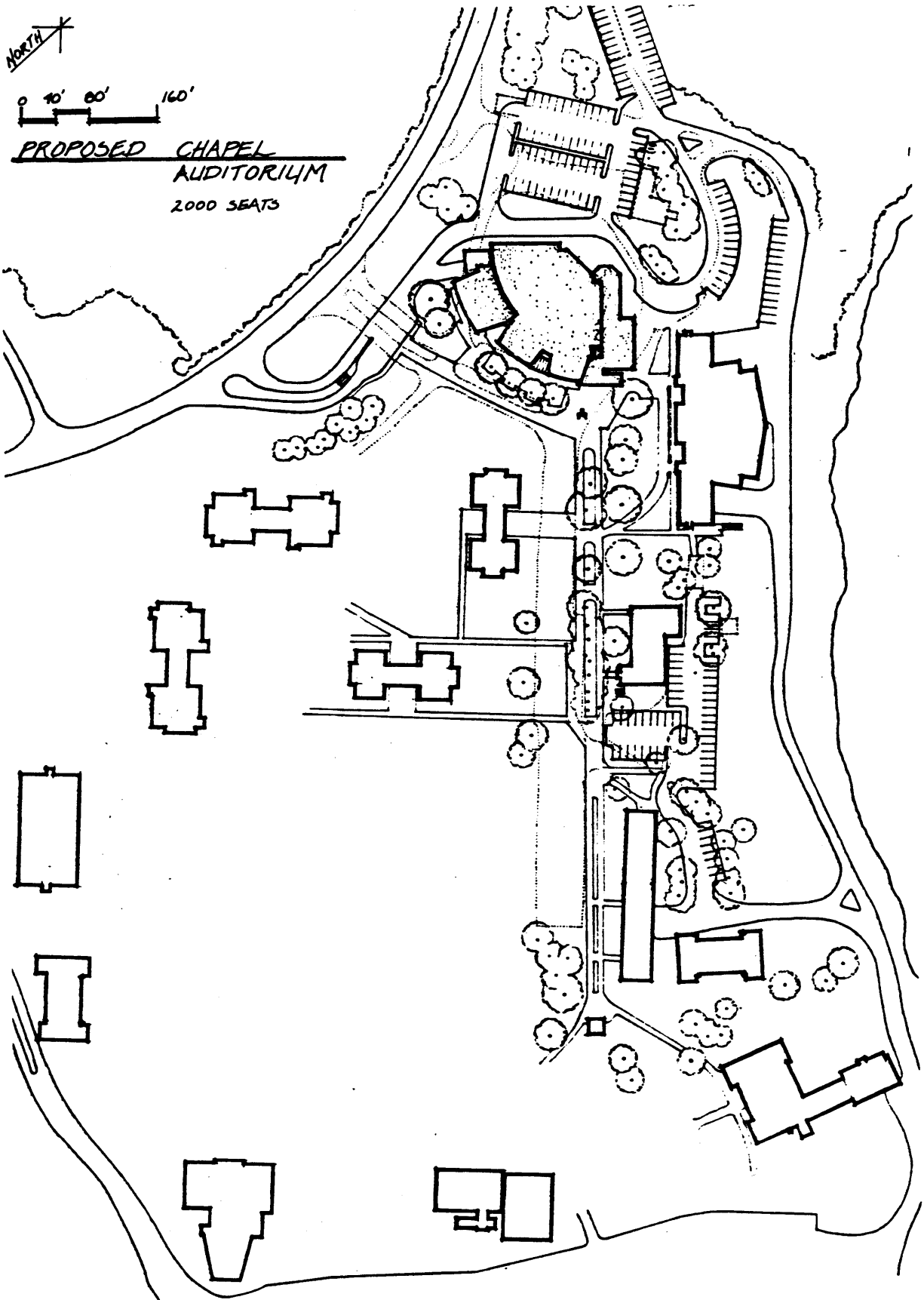

BIBLIOGRAPHY

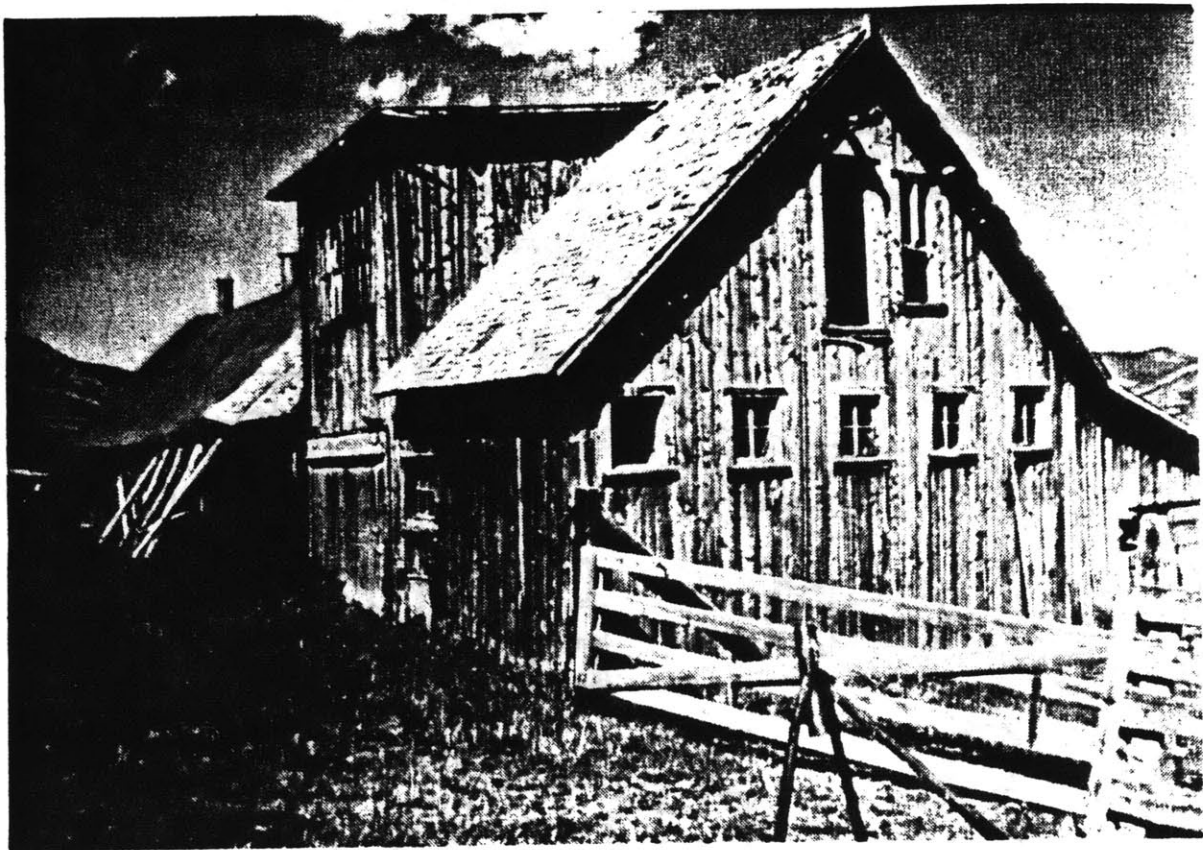

- Alexander, Christopher, et al. A Pattern Language. New York: Oxford University Press, 1977.
- Allen, Edward. Stone Shelters. Cambridge, MA: The MIT Press, 1969.
- Anderson, Bruce. The Solar Home Book. Harrisville, N.H.: Cheshire Books, 1976.
- Bearbeitung, Redaktionelle and Fleig, Karl, editors. Alvar Aalto. Scarsdale, New York: Whittenborn & Co., 1963.
- Bible, The Holy. King James Version (KJV) and New International Version (NIV).
- Butti, Ken and Perlin, John. A Golden Thread: 2500 Years of Solar Architecture and Technology. Palo Alto: Cheshire Books, 1980.
- Cardwell, Kenneth H. Bernard Maybeck: Artisan, Architect, Artist. Salt Lake City: Peregrine Smith, 1977.
- Chastain, Thomas Robert. Explorations of Collective Form: A Design Vocabulary Using Directional Village Forms as References. M.I.T., M. Arch. Thesis, June 1982.
- Ching, Francis D. K. Architecture: Form, Space & Order. New York: Van Nostrand Reinhold Co., 1979.
- Connah, Roger and Pietilä, Reima. "Unsettled Architecture." Space & Society 17. Sansoni & MIT: MIT Press, March 1982, pp. 6-17.
- Current, William (photos) & Scully, Vincent (text). Pueblo Architecture of the Southwest. Austin, TX: Univ. of Texas Press, 1971.
- Egelius, Mats. "An Architect on the Move." Space & Society 17. Sansoni & MIT: The MIT Press, March 1982, pp. 26-37.
- Erskine, Ralph. "Building in the Arctic." Architectural Design. May 1960, pp. 194-197.
- _____. "Eight Buildings in Sweden." The Architectural Review. Vol. CXVI, No. 691, July 1954, pp. 9-19.
- Ewenstein, Neal and Wade, Alex. 30 Energy-Efficient Houses You Can Build. Emmaus, PA: Rodale Press, 1977.

- Eyck, Aldo van. "The Enigma of Vast Multiplicity." Harvard Educational Review-Architecture of Education. Vol. 39, No. 4, Cambridge, MA, 1969.
- Fleig, Karl, ed. Alvar Aalto: 1963-1970. New York: Praeger Publishers, 1971.
- Futagawa, Yukio. The Roots of Japanese Architecture. 1962.
- Ghosh, Bijit. "Jaisalmer: Urban Form & Pattern of a Medieval Indian Town." Urban & Rural Planning Thought. Vol. XI, No. 1, Jan. 1968. New Dehli, India: School of Planning & Architecture. pp. 51-54.
- Gilpin, Laura. The Pueblos: A Camera Chronicle. New York: Hastings House, 1941.
- Grillo, Paul Jacques. Form, Function & Design. New York: Dover Publishers, Inc., 1960.
- Hajian, Paul. The Essence of Splace. M.I.T. M. Arch. Thesis May, 1982.
- Harada, Jiro. The Lesson of Japanese Architecture. Boston, MA: Charles T. Branford Co., 1954.
- Herdeg, Klaus. "Jaisalmer: A City Mansion." Plates from an exhibit at Cornell University, 1967. Courtesy of Gunter Nitsche.
- Hitchcock, Henry-Russell. In the Nature of Materials. New York, NY: Da Capo Press, Inc., 1942.
- Hix, John. The Glass House. Cambridge, MA: The MIT Press, 1974.
- Jain, Kulbhushan. "Jaisalmer, India: Morphology of a Desert Settlement." A+U, no. 74, 77:02, pp. 13-19.
- Johnson, Timothy E. Solar Architecture: The Direct Gain Approach. New York: McGraw-Hill Book Company, 1981.
- Judd, Neil M. The Architecture of Pueblo Bonito. Washington, DC: The Smithsonian Institute, June 30, 1964.
- Kensetsusho. Guide Book to Japanese Architecture. Vol. 3 Kansai District, 1963.
- King, Patrick. Pueblo Indian Religious Architecture. Salt Lake City, Utah: Publisher's Press, 1975.
- Knowles, Ralph, L. Energy and Form: An Ecological Approach to Urban Growth. Cambridge, MA: The MIT Press, 1974.

- Kostof, Spiro. Caves of God: The Monastic Environment of Byzantine Cappadocia. Cambridge, MA: The MIT Press, 1972.
- Lobell, John. Between Silence & Light: Spirit in the Architecture of Louis I. Kahn. Boulder, CO: Shambhala Press, 1979.
- Madow, Ben. Edward Weston: Fifty Years. New York: Aperture, Inc., 1973. p. 186.
- Mazria, Edward. The Passive Solar Energy Book. Emmaus, PA: Rodale Press, 1979.
- McCoy, Esther. Five California Architects. New York: Praeger Publishers, 1975.
- McHarg, Ian L. Design with Nature. Garden City, NY: Doubleday & Co., Inc., 1971.
- Meyer, John and Margaret. Patterns of Association: Connections Between the Inner and Outer Landscape. First Draft Manuscript. Cambridge, MA, Sept. 1978.
- Morton, David. "International Breed: Juddmonte Farm; Wargrave-on-Thames; Berkshire, England." Progressive Architecture. June, 1983, pp. 86-89.
- Norberg-Schulz, Christian. Genius Loci: Towards a Phenomenology of Architecture. New York: Rizzoli International Publications, Inc., 1980.
- Olkowski, Bill and Helga, et al. The Integral Urban House. San Francisco: Sierra Club Books, 1979.
- Ray, Stefano. Ralph Erskine: Architettura di bridolage e partecipazione. Bari: Dedalo Libri, 1978.
- Rudofsky, Bernard. Architecture Without Architects. Garden City, NY: Doubleday & Co., Inc., 1964.
- _____. The Prodigious Builders. New York: Harcourt Brace Jovanovich, 1977.
- Scully, Vincent. Pueblo/Mountain, Village, Dance. New York: The Viking Press, 1972.
- Shelter. Bolinas, CA: Shelter Publishers, 1973.
- Smith, Maurice. "Fragments of theory/practice." Space & Society 18, ed. by Giancarlo De Carlo. Cambridge, MA: The MIT Press, June 1982, pp. 36-51.

_____. "Not-Writing on Built-Form." Harvard Educational Review-Architecture and Education. Vol. 39, No. 4, Cambridge, MA, 1969.

_____. "Particular Associative Habitable (Built) Environments." Progressive Architecture, March 1982. pp. 100-103.

Smithson, Alison, ed. Team Ten Primer. Cambridge, MA: The MIT Press, 1968.

Steinberg, Saul. "Drawings." Harvard Educational Review-Architecture and Education. Vol. 39, No. 4, Cambridge, MA, 1969.

"Sun Worship." Encyclopaedia Britannica. Vol. 21, p. 429, 1973. Chicago: William Benton, Publisher.

Susuki, Mitsuru. Minka. Japan: Shogakkon, 1975.

"Thorncrown Chapel." E. Fay Jones and Ass., Architects. A+U. June 1981, No. 129, pp. 95-98.

Toffin, Gerard, ed. L'Homme et la Maison en Himalaya: Ecologie du Nepal. Paris, France: Editions du Centre National de la Recherche Scientifique, 1981.

Wright, David and Andrejko, Dennis A. Passive Solar Architecture: Logic & Beauty. New York: Van Nostrand Reinhold Company, 1982.

✓
Wright, Frank Lloyd. A Testament. New York: Bramhall House, 1957.

FOOTNOTES



1. Bible, The Holy. Genesis 1:1-15 (KJV).
2. John Lobell. Between Silence & Light (Boulder, CO: Shambhala Press, 1979) p. 22.
3. Francis D. K. Ching. Architecture: Form, Space, Order (NY: Van Nostrand Reinhold Co., 1979) p. 180.
4. Frank Lloyd Wright. A Testament (NY: Bramhall House, 1957) pp. 253-4.
5. Bible. I John 1:5 (KJV).
6. Ibid., John 1:9-10.
7. Ibid., I Timothy 3:16.
8. Ibid., Hebrews 3:4 (NIV).
9. Ibid., Genesis 1:14-18 (KJV).
10. Vincent Scully. Pueblo/Mountain, Village, Dance (NY: The Viking Press, 1972) p. 4.
11. Ibid., p. 7.
12. Ibid., pp. 7, 9.
13. Timothy E. Johnson. Solar Architecture: The Direct Gain Approach (NY: McGraw-Hill Book Co., 1981) p. 37.
14. Edward Mazria. The Passive Solar Energy Book (Emmanus, PA: Rodale Press, 1979) pp. 15-16.
15. Johnson, p. 29.
16. Ibid., p. 38.
17. Ibid., p. 31.
18. Ibid., p. 105.
19. Ibid., p. 104.
20. Mazria, p. 134.
21. Johnson, p. 34.
22. Ibid., 55.

23. Ken Butti & John Perlin. A Golden Thread: 2500 Years of Solar Architecture (Palo Alto: Cheshire Books, 1980) p. 5.

24. Ibid., p. 17.

25. Mazria, p. 79.

26. Johnson, p. 86.

27. Ibid., p. 33.

28. Ibid., p. 34.

29. Ibid.

30. David Wright & Dennis A. Andrejko. Passive Solar Architecture: Logic & Beauty (NY: Van Nostrand Reinhold Co., 1982) p. 203.

31. Butti, p. 3.

32. Bijit Ghosh. "Jaisalmer: Urban Form & Pattern of a Medieval Town." Urban & Rural Planning Thought, Vol. XI, No. 1, Jan. 1968 (New Dehli, India: School of Planning & Architecture) p. 53.

33. "Design with Microclimate," Course no 4.071J, MIT Dept. of Architecture, Lecture by John Furlong, Fall 1983.

34. Ibid., Lecture by Timothy Johnson.

35. Results of conversation with Rich Furman (fern-man; form-man); Dec. 17, 1983; 12:20 PM, MIT room 10-485.

36. Ralph L. Knowles. Energy & Form (Cambridge, MA: MIT Press, 1974) p. 88.

37. Maurice Smith. "Fragments of Theory/Practice." Space & Society 18. Giancarlo De Carlo, ed. (Cambridge, MA: MIT Press, June 1982) p. 55.

38. Bible. James 1:22-24 (NIV).

ILLUSTRATION CREDITS



Photographs and drawings not credited are by the author.
Where source information is abbreviated, see Bibliography
for more complete reference.

Page

- 8 Singing Sand Mountain, Nevada.
- 10 Cote basque dite Cote d' Argent, entre Socoa et
l'Espagne; Photo by A. Traincano; from Silence & Light
(Lobell), p. 51.
- 12 "The Voyage of Life: Old Age," 1842; Thomas Cole;
National Gallery of Art, Washington; from postcard no.
2553, courtesy of Dennis Carlberg.
- 13 Design with Nature (McHarg), p. 118, ill. 76.
- 14 "Sunrise at Stonehenge on the summer solstice," 1976;
Rachel Dutton; from The Solar Home Book (Anderson, p.
54.
- 15 Sculpture of The Crucifixion; artist unknown; Mount
Angel Benedictine College; Mount Angel, Oregon; cour-
tesy of Dennis Carlberg.
- 18 Maurice Smith; "Not-Writing on Built-Form;" Harvard
Educational Review, Vol. 39, No. 4.
- 19 Aztec Temple; Monte Alban, Oaxaca; Pueblo (Scully)
ill. I:5.
- 20 A. Temple of Athena, Paestum; Ibid., ill. I:9.
B. Temple of Hera with conical hill; Ibid., ill. I:8.
- 21 David Wright house; Sea Ranch, CA; from 30 Energy-
Efficient Houses ... (Ewenstein) p. 165.
- 22 Longhouse cave pueblo; Pueblo Architecture of the
Southwest (Current) p. 50, fig. 22.
- 23 Ritual dance; Pueblo (Scully) ill. III:71j.
- 25 Passive Solar Energy Book (Mazria) p. 9, fig. II-2.
- 26 B. Solar Architecture: The Direct Gain Approach
(Johnson) p. 29, fig. 3.6.
- 28 B. Pattern Language (Alexander) p. 748.

Page

- 29 Passive (Mazria) p. 30, fig. III-1.
- 30 Ibid.
- 32 Ibid., p. 139, fig. IV-11b.
- 33 Form, Function & Design (Grillo) p. 115.
- 34 B. Pattern Language (Alexander) p. 989.
- 36 Ibid., p. 513.
- 37 A. Passive (Mazria) p. 11, fig. II-4.
B. Pattern Language (Alexander) p. 393.
- 38 A. Socrates; Golden Thread (Butti) p. 6.
B. Passive (Mazria) p. 91.
- 39 A. Ibid., p. 72, photo IV-4a.
B. Acoma pueblo - drawing & caption; Golden Thread
(Butti) p. 174.
- 40 Passive (Mazria) p. 263, fig. IV-27a.
- 46 Passive Solar Architecture: Logic & Beauty (Wright,
David); drawing & caption, p. 209.
- 47 Passive (Mazria) p. 221, fig. IV-21a.
- 50 A. Neolithic cave; Shelter, p. 5.
B. "Thorncrown Chapel" (Jones, E. Fay, architect); A+U,
June 1981, p. 98.
- 52 A. Tokali Kilise - "Boss Church;" Caves of God (Kostof)
p. 96-7, fig. 13.
B. "Thorncrown Chapel," Ibid., p. 96.
- 59 Shelter, p. 52.
- 60 B. Photo of igloo; World Architecture (ed. by Trewin
Copplesstone) NY: Crescent Books; ill. 216.
- 61 B. Passive (Wright) p. 186.
- 62 Vernacular house in Ladakh; Paul Murdoch; L'Homme et
la Maison en Himalaya (Toffin, ed.) p. 269.
- 63 Ibid., pp. 267-8.

Page

- 64 A. Model of Olynthus; photo & caption; Golden Thread (Butti) p. 7.
B. House plan, Delos; drawing & caption; Ibid., p. 11.
- 65 A. Olynthus block; drawing & caption; Ibid., p. 6.
B. Axon of Priene house; drawing & caption; Ibid., p. 5.
- 67 A. Roots of Japanese Architecture (Futagawa) ill. 71.
B. Lesson of Japanese Architecture (Harada) p. 103.
- 68 "Jaisalmer, India;" A+U (Jain) no. 74, 77:02, p. 15.
- 69 "Jaisalmer: A City Mansion" (Herdeg) ill. 11b;
courtesy of Gunter Nitsche.
- 70 Wind blown tree; Form Function & Design (Grillo) p. 102.
- 71 Sand pile transformation; Energy & Form (Knowles) fig. 3.14.
- 72 A. Saltbox drawing & caption; Golden Thread (Butti) p. 175.
C. "8 Buildings in Sweden" (Ralph Erskine, architect) The Architectural Review July 1954, p. 11, fig. 4.
- 73 Architecture Without Architects (Rudofsky) ill. 132.
- 75 "Jaisalmer" (Herdeg) ill. 11b.
- 76 B. Passive (Wright) p. 231.
- 77 A. Drawing & caption; Prodigious Builders (Rudofsky) p. 286, ill. 239.
B. Photo; Architecture Without Architects (Rudofsky) ill. 115.
- 81 "Fern in the Redwoods," 1937; Edward Weston, p. 186.
- 84 A. Drawing & caption; Nature of Materials (Hitchcock) ill. 271.
- 85 A. Ibid.
- 86 A. Drawing & caption; Golden Thread (Butti) p. 45.
B. Passive (Mazria) p. 35.

Page

- 87 A. Section drawings; Energy & Form (Knowles) fig. 2.15.
B. Plan & Legend; Ibid., fig. 2.14.
- 88 A. Block at Olynthus; Ibid., fig. 6.1.
B. Drawing of Priene; Golden Thread (Butti) p. 8.
- 89 A. Sun/shadow diagrams & caption; Energy & Form
(Knowles) fig. 2.27.
B. Author's tracing of axon from ibid., fig. 2.26.
- 96 A. Ibid., fig. 6.2.
B. Golden Thread (Butti) p. 11.
- 98 A. "Jaisalmer" (Herdeg) ill. 11b.
B. Ibid., ill. 12.
- 124 Sand dunes; Design with Nature (McHarg) p. 119, ill. 77.
- 130 Ibid., p. 69, ill. 55.
- 131 Winter landscape, Scotland; Milton C. Butcher, Jr.
- 132 A. Red Mt.; Aspen, CO.
- 134 A. Aldo Van Eyck quote; Team Ten Primer (Smithson) p. 5.
B. Map of Scandanavia; Genius Loci (Norberg-Schulz)
ill. 59.
- 135 Maurice Smith "Not-Writing on Built-Form;" Harvard
Educational Review, Vol. 39, No. 4.
- 141 Author's tracing of Acropolis from Design with Nature
(McHarg) p. 28.
- 142 A. Ibid., p. 122, ill. 78.
B. Author's tracing of haylofts from Form, Function &
Design (Grillo) p. 84.
- 143 A. Vitorchiano; Genius Loci (Norberg-Schulz) p. 145,
ill. 236.
B. Rocks-Snow-Trees; Aspen Mt.; Aspen, CO.
- 144 A. Cedar tree; Windstar Ranch; Snowmass, CO.
B. Treehouse in Buyay, New Guinea; Architecture without
Architects (Rudofsky) ill. 110.
- 145 "Captain" Kirk Lawrence in Lucky Find Glades; Aspen
Highlands.

Page

- 146 "The Path of the Wanderer;" Sacro Speco, Subiaco;
Genius Loci (Norberg-Schulz) p. 12, ill. 7.
- 147 Telc, Czechoslovakia; Architecture without Architects
(Rudofsky) ill. 78.
- 148 Malm Funeral Home; Aalto (Bearbeitung and Fleig) p. 162.
- 151 Pattern Language (Alexander) p. 1050.
- 152 A. Author's tracing of James residence by Charles
Greene; from 5 California Architects (McCoy) p. 145.
- 153 B. Sever Hall; Harvard University; Cambridge, MA;
H. H. Richardson, architect.
- 154 A. Author's tracing of Wolfe House by R. M. Schindler;
from 5 California Architects (McCoy) p. 168.
- 155 A. Alvar Aalto: 1963-1970 (Fleig) p. 154.
B. Flagg House by Bernard Maybeck; Architecture: Form,
Space & Order (Ching) p. 348.
- 156 Author's tracing of Juddmonte farm; PA 6:83 (Morton)
p. 87; Theodore M. Ceraldi, architect.

Notes on Illustration Procedure & Thesis Assembly

Illustrations from books: Kodak Copier Model 250

Author's tracing of photos to emphasize information and provide clearer copy:

Pages 89B, 139, 140 (base for 136, 138), 141, 142B, 152A, 153A, 154A, 156.

Reproduction of slides via color xerox (dot screen pattern built-in) for pasted-up original:

Pages 3, 6, 8, 15, 16, 24, 35, 78, 149, 158, 166.

Sketches of Design Vocabulary Section:

3B sketching pencil; most of the sketches were reduced (65%; 74%) by the Kodak 250.

Reduction process of Chapel/Auditorium (pages 163-165):

original - pencil on vellum.

reduction - Xerox 2080; 45% onto vellum.

reproduction - Kodak Model 250

Assembly:

- Text and illustrations were trimmed to size and attached to 20 lb. paper using Spray Mount Adhesive.
- Captions and corrections were applied by typing/writing onto self-adhesive labels and correcting tape.
- Reduced work, especially lettering and smaller drawings, tended to fill-in between lines and letters; removal of copier ink with an exacto blade was the usual remedy.
- Page numbers were stamped onto self-adhesive labels, then applied to pages.
- Some xeroxes from books were touched up with a "000" pen to add clarity (see pages 20B, 39A, 60B).

BLOOM COUNTY

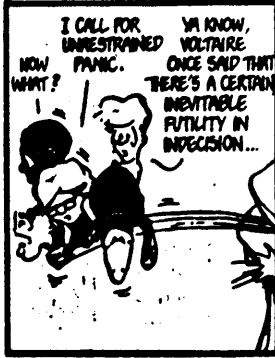
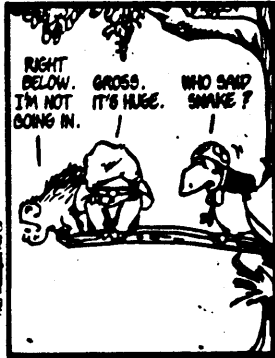

By Berke Breathed



GARFIELD

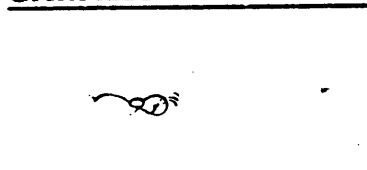

OH, NO!

By Jim Davis

