

TL552

.M41

1F614

no. 99-1

FLIGHT TRANSPORTATION LABORATORY
REPORT R99-1

AIRLINE ALLIANCES: THE AIRLINE
PERSPECTIVE

PABLO E. FERNANDEZ DE LA TORRE

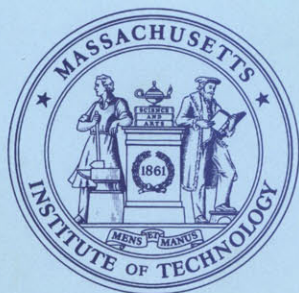

DEPARTMENT OF
AERONAUTICS AND ASTRONAUTICS
MASSACHUSETTS INSTITUTE OF TECHNOLOGY
CAMBRIDGE, MASSACHUSETTS 02139-4307

FLIGHT TRANSPORTATION LABORATORY
REPORT R99-1

AIRLINE ALLIANCES: THE AIRLINE
PERSPECTIVE

PABLO E. FERNANDEZ DE LA TORRE

Airline Alliances: The Airline Perspective

by

Pablo E. Fernandez de la Torre

Submitted to Department of Aeronautics and Astronautics
on May 14, 1999 in Partial Fulfillment of the Requirements for the
Degree of Master of Science in Transportation

Abstract

Airline alliances are one of the critical issues faced by the airline industry in the 1990s. In this thesis, an overview of the most significant impacts that the formation of alliances have brought to the industry—especially to airline management—is presented.

Part I presents several frameworks to help understand why alliances have become so critical for the participating airlines. A definition of airline alliances, different typologies to classify them, the main motivations for their formation, and the recent trends in the industry are presented. The alliances' main objective is the increase of market coverage, though the strengthening of market position on certain routes and the reduction of costs are additional sources of competitive advantage they provide to the participating airlines. Alliances can also bring many benefits to customers in terms of improved service, although they represent a threat for sustainable competition.

Part II analyzes two critical problems faced by airline management. First, it is analyzed the effect of the network connectivity through an alliance hub-to-hub linkage scheme on the increase in market share. The analysis shows that the alliance hub-to-hub link represents a significant source of additional traffic for the alliance. Accessibility, a measure developed for network connectivity, has proven to be a critical factor in increasing market share on the alliance hub-to-hub link. Scheduling coordination within alliances, therefore, should consider the maximization of accessibility as a critical driver of demand. The second problem analyzed is the introduction of codesharing into revenue management systems. There are four different problems associated with it, which are interrelated in practice. One of them, the valuation and seat inventory control process for codeshare traffic is analyzed in detail. Two main revenue management approaches to handle codesharing are presented: The proration approach and the fully integrated approach. The latter aims to maximize the combined revenue and implies higher complexity in its implementation, while the former has easier implementation. Under the proration approach, there is a significant source of revenue loss due to an incorrect valuation of the revenue contribution brought by codeshare traffic. Although a solution is proposed to solve this problem, a final answer should include a redefinition of the way codesharing agreements are currently established.

Thesis Advisors: Peter P. Belobaba, Professor of Aeronautics and Astronautics
 John-Paul B. Clarke, Professor of Aeronautics and Astronautics

A Belén, con todo mi cariño

Table of Contents

| | |
|---|-----------|
| I. Introduction | 17 |
| I.I. Motivation and Goals of the Thesis | 17 |
| I.II. Structure of the Thesis..... | 18 |

PART I FRAMEWORKS FOR AIRLINE ALLIANCES

| | |
|--|-----------|
| Chapter 1. Concepts, Motivations and Trends | 23 |
| 1.1. Introduction | 23 |
| 1.2. The Concept of Airline Alliances..... | 24 |
| 1.3. The Concept of Codesharing..... | 29 |
| 1.4. Airline Alliances Typologies | 33 |
| 1.4.1. The Scope of the Alliance..... | 33 |
| 1.4.2. Stability and Structural Complexity | 37 |
| 1.4.3. The Three-Stage Evolution | 40 |
| 1.4.4. Other Alliance Distinctions..... | 42 |
| 1.5. Motivations for Airline Alliances..... | 43 |
| 1.6. Trends in Airline Alliances | 49 |
| 1.6.1. Alliance Evolution..... | 49 |
| 1.6.2. Recent Alliance Trends..... | 53 |
| Chapter 2. Economic Impacts of Airline Alliances..... | 59 |
| 2.1. Introduction | 59 |
| 2.2. Impacts on the Participating Airlines | 60 |
| 2.2.1. Positive Impacts | 60 |
| 2.2.1.1. Increase of Network Coverage | 61 |
| 2.2.1.2. Increase of Traffic Volume | 64 |
| 2.2.1.3. Reduction in Costs..... | 68 |
| 2.2.1.4. Access to Congested Airports and Regulated Foreign Markets.. | 73 |
| 2.2.1.5. Avoid Competition with Partner Airlines and Reinforce Dominance..... | 75 |
| 2.2.2. Negative Impacts..... | 75 |
| 2.3. Impacts on the Rest of the Industry and Stakeholders..... | 78 |
| 2.3.1. Positive Impacts | 78 |

| | |
|---|----|
| 2.3.1.1. Increase of Accessibility to Passengers | 78 |
| 2.3.1.2. Improvement of Passenger Service..... | 78 |
| 2.3.1.3. Potential Reduction of Fares | 79 |
| 2.3.1.4. Reduction of Air Traffic Congestion | 79 |
| 2.3.2. Negative Impacts..... | 79 |
| 2.3.2.1. Exercise of Market Power | 80 |
| 2.3.2.2. Multiple Listing on CRS Displays..... | 82 |
| 2.3.2.3. Passenger Confusion and Inconvenience | 82 |
| 2.3.2.4. Concentration of Traffic on Alliance Hubs..... | 83 |
| 2.3.2.5. Impact on Fares. Recent Studies..... | 84 |
| 2.4. Conclusions | 86 |

PART II

IMPACTS OF AIRLINE ALLIANCES ON AIRLINE MANAGEMENT. NETWORK CONNECTIVITY AND REVENUE MANAGEMENT

Chapter 3. Using Network Connectivity as a Strategy for Market Growth..... 91

| | |
|--|-----|
| 3.1. Introduction | 91 |
| 3.2. The Alliance Hub-to-Hub Model | 93 |
| 3.3. The Data of the Analysis..... | 95 |
| 3.4. Market Share Analysis..... | 96 |
| 3.5. Accessibility: A Metric for Alliance Network Connectivity | 104 |
| 3.6. Relationship between Accessibility and Market Share | 111 |
| 3.6.1. Evolution of Accessibility and Market Share | 111 |
| 3.6.2. The Regression Model..... | 118 |
| 3.6.3. Accessibility Versus Frequency | 127 |
| 3.6.4. Sensitivity Analysis | 129 |
| 3.7. Discussion of Main Assumptions..... | 132 |
| 3.8. Conclusions and Further Considerations | 135 |

Chapter 4. Impacts of Codesharing for Revenue Management..... 139

| | |
|--|-----|
| 4.1. Introduction | 139 |
| 4.2. Problems and Dimensions of Codesharing for Revenue Management | 141 |
| 4.3. Review of Revenue Management..... | 144 |
| 4.3.1. Conventional Revenue Management..... | 146 |
| 4.3.2. O&D Revenue Management | 148 |
| 4.4. Types and Aspects of Codesharing for Revenue Management | 151 |
| 4.4.1. Types of Codesharing Agreements | 151 |

| | |
|--|------------|
| 4.4.1.1. Allocation Criterion | 152 |
| 4.4.1.2. Revenue Sharing Criterion | 154 |
| 4.4.2. The Two Aspects of Codesharing for Revenue Management | 158 |
| 4.5. Current RMS Approaches for Codesharing | 160 |
| 4.5.1. Alliance Proration Approach..... | 161 |
| 4.5.2. Fully Integrated Approach | 163 |
| 4.5.3. Comparison of the Two Approaches | 165 |
| 4.6. Issues Concerning Seat Inventory Control Models | 168 |
| 4.6.1. Partner-Operated Codesharing | 169 |
| 4.6.1.1. Current System Limitations..... | 169 |
| 4.6.1.2. Potential Modeling Solutions | 178 |
| 4.6.1.3. Simulation Results | 185 |
| 4.6.2. Airline-Operated Codesharing | 185 |
| 4.6.2.1. Current System Limitations..... | 186 |
| 4.6.2.2. Potential Modeling Solutions | 187 |
| 4.6.3. Fully Integrated Approach | 189 |
| 4.7. Conclusions | 196 |
| Chapter 5. Conclusion | 201 |
| 5.1. Thesis Contribution | 201 |
| 5.2. Further Research..... | 208 |
| References..... | 211 |

List of Figures

Chapter 1

| | |
|--|----|
| Figure 1.1. Distinction between marketing alliances and strategic alliances | 28 |
| Figure 1.2. Typical codesharing situation on international markets | 30 |
| Figure 1.3. Parallel and Complementary codesharing | 32 |
| Figure 1.4. Network scheme of a global strategic alliance..... | 34 |
| Figure 1.5. Domestic strategic alliance. Overlapping of networks..... | 35 |
| Figure 1.6. Regional strategic alliance. Share of complementary networks | 36 |
| Figure 1.7. Classification of different alliance types based on the complexity and commitment of the arrangement | 38 |
| Figure 1.8. The stability matrix for airline alliances..... | 39 |
| Figure 1.9. Airline alliances as strategic weapons..... | 48 |
| Figure 1.10. Alliance growth during the period 1994-1998..... | 54 |

Chapter 2

| | |
|---|----|
| Figure 2.1. The impacts of alliances for the participating airlines..... | 61 |
| Figure 2.2. Northwest/KLM alliance's hub-to-hub link between the US and the Middle East | 62 |
| Figure 2.3. Northwest flights to Europe before the alliance formation..... | 63 |
| Figure 2.4. Northwest flights to Europe after the alliance formation | 63 |
| Figure 2.5. Alliances' mechanism to capture additional traffic..... | 64 |
| Figure 2.6. Number of passengers traveling on connecting United/British Midland flights between the US and Glasgow before and after the codeshare agreement..... | 66 |
| Figure 2.7. Evolution of the Northwest/KLM transatlantic traffic | 67 |
| Figure 2.8. Effects of alliances on the cost structure of the alliance members..... | 68 |
| Figure 2.9. Evolution of NW/KLM load factors in their transatlantic flights | 72 |
| Figure 2.10. Airlines with biggest share of take-off and landing slots at European airports in 1995 | 74 |
| Figure 2.11. Multiple listing on CRS displays | 83 |

Chapter 3

| | |
|--|----|
| Figure 3.1. The alliance link versus competitor links | 92 |
| Figure 3.2. Northwest/KLM alliance network..... | 94 |

| | |
|--|-----|
| Figure 3.3. Northwest/KLM share of the transatlantic traffic out of Nashville, Tennessee..... | 98 |
| Figure 3.4. Northwest/KLM share of the transatlantic traffic out of Kansas City, Missouri..... | 98 |
| Figure 3.5. Northwest/KLM share of the transatlantic traffic out of St. Louis, Missouri..... | 99 |
| Figure 3.6. Impact of O&D size on market share achieved by the alliance link. Traffic during the period 1990 to 1997..... | 101 |
| Figure 3.7. Effect of O&D size on the NW/KLM traffic carried by market. O&D market-year observations on the period 1990-1997..... | 104 |
| Figure 3.8. Definition of the connecting convenience function | 107 |
| Figure 3.9. Effect of the number of stops in the accessibility formulation | 109 |
| Figure 3.10. Definition of accessibility | 110 |
| Figure 3.11. Evolution of accessibility versus market share in Nashville | 112 |
| Figure 3.12. Evolution of accessibility versus market share in Kansas City | 112 |
| Figure 3.13. Evolution of accessibility versus market share in St. Louis | 113 |
| Figure 3.14. Evolution of accessibility versus market share, Nashville. Destinations beyond Amsterdam..... | 114 |
| Figure 3.15. Evolution of accessibility versus market share, Kansas City. Destinations beyond Amsterdam..... | 114 |
| Figure 3.16. Evolution of accessibility versus market share, St. Louis. Destinations beyond Amsterdam..... | 115 |
| Figure 3.17. Evolution of accessibility versus market share in the market Nashville-Amsterdam..... | 116 |
| Figure 3.18. Evolution of accessibility versus market share in the market Kansas City-Amsterdam..... | 117 |
| Figure 3.19. Evolution of accessibility versus market share in the market St. Louis-Amsterdam..... | 117 |
| Figure 3.20. Cross-Tabulation of changes in accessibility versus changes in market share..... | 125 |
| Figure 3.21. Different connecting convenience functions used for the sensitivity analysis | 130 |
| Figure 3.22. Impact of accessibility on market share as a function of t_{opt} | 131 |
| Chapter 4 | |
| Figure 4.1. Problems and dimensions of codesharing for revenue management | 142 |
| Figure 4.2. The two components of revenue management..... | 145 |
| Figure 4.3. Modern components of modern RMSs..... | 146 |

| | |
|--|-----|
| Figure 4.4. Booking limits determination under conventional revenue management | 147 |
| Figure 4.5. Reservation Process under conventional revenue management | 148 |
| Figure 4.6. Booking limits determination under O&D revenue management with virtual buckets | 150 |
| Figure 4.7. Reservation Process under O&D revenue management with virtual buckets | 151 |
| Figure 4.8. Example that illustrates the three proration methods | 157 |
| Figure 4.9. Example that illustrates the two aspects of codesharing for revenue management | 160 |
| Figure 4.10. Logical evolution of the codesharing approach | 166 |
| Figure 4.11. Illustrative example: airline perspective versus alliance perspective..... | 167 |
| Figure 4.12. The tension between the airline perspective and the alliance perspective | 168 |
| Figure 4.13. Incorrect valuation of the passenger revenue contribution. Conventional RMS..... | 172 |
| Figure 4.14. Incorrect valuation of the passenger revenue contribution under O&D revenue management | 175 |
| Figure 4.15. Impact of uncertain capacity on codeshare legs..... | 177 |
| Figure 4.16. Determination of equivalent fare classes for codeshare traffic..... | 180 |
| Figure 4.17. New path-class valuation process | 181 |
| Figure 4.18. Example of a prorate table | 182 |
| Figure 4.19. Adjustment of the pseudo capacity on codeshare legs | 183 |
| Figure 4.20. Bookings per departure date on a codeshare city-pair..... | 184 |
| Figure 4.21. Revenue loss under airline-operated codesharing | 187 |
| Figure 4.22. Seat inventory control process on codeshare legs. Decentralized approach..... | 192 |
| Figure 4.23. Example of decentralized revenue management on a codeshare leg. If partners use different systems, EMSRA(S) and EMSRB(S) cannot be compared..... | 195 |

List of Tables

Chapter 1

| | |
|---|----|
| Table 1.1. Airline alliance growth during the years 1994-1998..... | 53 |
| Table 1.2. Survival rates for international alliances | 55 |
| Table 1.3. Areas of coordinated activities within airline alliances..... | 55 |

Chapter 2

| | |
|---|----|
| Table 2.1. Number of Northwest/KLM passengers traveling between 34 US and 30 European and Middle Eastern cities, and alliance's market share | 67 |
|---|----|

Chapter 3

| | |
|--|-----|
| Table 3.1. Annual outbound transatlantic traffic out of the three airports..... | 97 |
| Table 3.2. Time parameters of the connecting convenience functions..... | 108 |
| Table 3.3. Results from the OLS regression | 121 |
| Table 3.4. Relative importance of each variable | 123 |
| Table 3.5. O&D markets used for the cross-tabulation exercise | 126 |
| Table 3.6. Accessibility versus frequency. Regression results | 128 |
| Table 3.7. Accessibility versus frequency. Relative importance of each variable | 128 |
| Table 3.8. Regression results for different values of t_{opt} | 130 |

Chapter 4

| | |
|--|-----|
| Table 4.1. Distribution of agreement types within United Airlines | 154 |
| Table 4.2. Comparison of the two approaches | 165 |

I. Introduction

I.I. Motivation and Goals of the Thesis

The motivation for selecting airline alliances as the topic of this thesis is the increasing eagerness found in the industry regarding alliances and the issues they bring. Most airline officials, airline experts, and academia do not hesitate to highlight the development of airline alliances as one of the most critical events experienced by the airline industry in the 1990s. In simple terms, airline alliances have become a “hot” topic.

A literature review on the topic of airline alliances reveals that the major part of the previous research has focused on the policy and economical implications of alliances. The impact of alliances on fares, the impact on passenger service, and the implications on the regulation of international aviation are the three topics most frequently addressed in articles and studies. Most of these studies are done from an exogenous perspective; exogenous in that they analyze the implications of airline alliances from a point of view external to the airlines participating within alliances.

However, the author’s belief is that the real challenges brought by alliances lay within the airline frontiers, and particularly within the area of airline management. Consequently, the focus of this thesis is taken from the point of view of the participating airlines, that is, from the airline perspective—hence, the title of the thesis.

Little research has been done on the implications of alliances for airline management, though most airline officials recognize that alliances continuously generate issues and challenges for their organizations, which require urgent action. In part due to the lack of homogenous criteria among carriers to approach the problems brought by alliances and

in part due to the complexity of such problems, it has been difficult to abstract the impacts of alliances for airline management and carry out research under scientific rigor. However, as alliances are becoming an increasingly common feature of the airline industry and move towards higher degrees of integration among alliance partners, there is a growing need for research in this area.

The goal of this thesis is to bring light to a field that, until today, had remained diffuse. Some research has been carried out regarding the implications of alliances for airline management at an organizational, structural, and strategic level, whereas little research has been carried out at an operational level. However, it is the author's belief that is at the operational level where most of the complexity brought by alliances must be faced by airline management, and consequently, where the biggest challenges and limitations for achieving further levels of alliance integration remain to be overcome. With this thesis, the author aims to contribute to the basis of further research for a common agenda to approach the issues brought by alliances in the next decade. The thesis aims to provide answers to questions such as: What are the benefits an airline should expect from forming an alliance? And what are the costs? How should revenue management deal with the introduction of codeshare traffic associated with the formation of an alliance? Which approach should it choose? Which revenue sharing methods should it consider? How should alliance partners coordinate their schedules in order to make the alliance more effective?

I.II. Structure of the Thesis

This thesis provides an overview of the most critical issues faced by the current airline industry regarding the formation of alliances. It is structured in two parts, each consisting of two chapters. Part I provides several frameworks to help understand why alliances have become so critical for the participating airlines as we approach the twentieth-first century. Part II presents two of the most important problems brought by alliances and faced by airline management.

Part I constitutes, in essence, an introduction to airline alliances. Chapter 1 provides a definition of the term “airline alliances”, as well as several typologies to differentiate among alliance types. It also presents the main motivations for the formation of alliances and the trends experienced by the airline industry in the last decades. Chapter 2 provides an overview of the economic impacts of alliances, both from the perspective of the participating airlines and the perspective of the industry stakeholders. It includes both negative and positive impacts.

In Part II, the management of network connectivity and the handling of codeshare traffic by revenue management are the two problems addressed. They represent two of the most important challenges regarding alliances that are faced by airline management today. The former is discussed in Chapter 3, while the latter is discussed in Chapter 4.

Finally, Chapter 5 summarizes the contribution of this thesis and proposes potential research to further the coordination of activities among alliance partners

PART I

FRAMEWORKS FOR AIRLINE ALLIANCES

Chapter 1

Concepts, Motivations, and Trends

1.1. Introduction

Airline alliances have become an increasingly common feature of the airline industry. Many articles in both airline and general-public magazines refer to airline alliances in one or other sense. Whether they are trumpeted as critical elements in the increase of airline performance or they are questioned on the benefits they yield to customers, airline alliances seems to generate a great expectation in both the academic and managerial community.

This chapter is intended to serve as an introductory step towards providing a framework to better understand airline alliances, the motivation behind them, and the alliance trend experienced by the airline industry worldwide.

The concept of airline alliances is first defined. As pointed out above, many articles refer to the word airline alliance; however, there is little agreement about its exact meaning. Articles are frequently vague in defining airline alliances, or they lack a satisfactory degree of specification. Now that airline alliances are consolidating as critical elements in the structure of the airline industry, there is a clear need for a definition of alliances that will capture all the different aspects of its meaning. In Section 1.2 several airline alliance definitions found in research studies are addressed. Then, the author's own definition is proposed, distinguishing between the more generic concept of airline alliances and the more specific concept of strategic airline alliances.

As the practice of codesharing is key in the development of airline alliances, Section 1.3 introduces the concept of codesharing. Chapter 4 will later focus on the different

aspects and types of codesharing agreements; however, Section 1.3 will present a first distinction between two types of codesharing: Complementary and parallel.

Section 1.4 presents several ways to classify airline alliances. As the particular characteristics of every type of alliance produce different impacts on markets, competition, and airline performance, these different classifications will help structure a framework for airline alliances, which in turn will help identify key aspects of each type of alliance. Three classifications are presented. The first one is based on the scope of the alliance, while the second and third ones are based on the managerial characteristics of the agreement.

Section 1.5 presents the main factors affecting the airline motivations for the formation of alliances. Chapter 2 will later elaborate on the economic impacts of alliances; however, this section should serve as an introduction to the main reasons why alliances have become so critical for airlines in the last decades of the twentieth century.

Finally, Section 1.6 presents a summary of the industry trends regarding airline alliance development since its origins in 1967, when the first codesharing agreement was established. First, a chronological evolution of alliances is addressed. Then, a review of the industry trends in the last decade is presented, including the present state of the art.

1.2. The Concept of Airline Alliances

The term airline alliance has no precise definition. The Merriam-Webster's Dictionary¹ defines alliances as "associations or unions formed for the furtherance of the common interest and aims of the members". Under this broad semantic umbrella, airlines have adopted the word "alliance" to refer to any situation in which they become involved with another carrier in the exchange of resources (physical assets, information, or brand image), as a means to improve their market position. The term alliance implies a "win-

¹ Merriam-Webster's Third New International Dictionary, Springfield, Massachusetts, 1986.

win” situation for its members, though the degree of member satisfaction varies significantly across the alliance spectrum found in the industry.

Oster (1994) defines corporate alliances “quite broadly to include any arrangement in which two or more firms combine resources outside of the market in order to accomplish a particular task or set of tasks”. Michael Zea (1998), in reference to international airline alliances, defines them as “marketing-based initiatives designed to combine the regional and transnational strengths of partner airlines to form massive international networks”. Youssef (1992) refers to equity airline alliances as “cooperative agreements between two independent airlines where a financial stake is assumed by one airline in another or is exchanged between both airlines”. Here, the broad semantic meaning with which the term airline alliance has been used in the industry will not be constrained. Thus, airline alliances will be considered as *any kind of agreement between independent carriers to mutually benefit from the coordination of certain activities in the provision of air transportation services*.

Historically, airlines have entered into interline agreements involving the coordination of activities such as baggage check-in, cargo carriage, and honoring of tickets between airlines (ICA, 1997). Starting in the late 1980s, however, airlines extended the degree of coordination with their partners to include a wider range of possibilities such as:

- *Codesharing* (defined in Section 1.3);
- Scheduling of flight arrival and departure times;
- Location of arrival and departure gates;
- Joint frequent flyer programs;
- Share of airport lounges and other ground facilities;
- Share of passenger services such as baggage handling, check-in and ticketing;
- Share of support services including maintenance and catering;
- Share of distribution and retailing functions;
- Joint purchasing (fuel, passenger-service goods, aircraft);
- Joint advertising campaigns. Creation of alliance brand recognition;
- Joint allocation of resources (fleet and crew planning);

- Equity investments in partner's stock (equity alliances).

Because the institutional arrangements linking airline activities are continually changing, the exact definition of what constitutes an airline alliance is vague. Nevertheless the above list represents a "fair" representation of the different options found in the industry.

The above list of coordinated activities has been intentionally sorted in order of increasing partner commitment. Joint advertising campaigns aimed to create alliance brand recognition, for example, require a higher degree of commitment from the alliance partners than the share of baggage handling facilities. It is within this distinction where the concept of **strategic airline alliances** fits in.

Parkhe (1993) defines strategic alliances as "relatively *enduring* interfirm cooperative arrangements, involving flows and linkages that utilize resources and/or governance structures from autonomous organizations, for the joint accomplishment of individual goals". Freidheim (1998) states that "there are many types of alliances, but commitment is what makes alliances strategic".

Yoshino and Rangan (1995) state that strategic alliances "link specific facets of the business of two or more firms in order to enhance the *competitive strategies* of the participant firms." They define strategic alliances as possessing simultaneously the following three necessary and sufficient characteristics:

- The two or more firms that unite to pursue a set of agreed upon goals **remain independent** subsequent to the formation of the alliance.
- The partner firms **share the benefits** of the alliance and **control** over the performance of assigned tasks --- perhaps the most distinctive characteristic of alliances and the one that makes them so difficult to manage.
- The partner firms **contribute on a continuing basis** in one or more **key strategic areas**, e.g., technology, products, and so forth.

In the air transportation arena, *Gellman Research Associates* (GRA) (1993) make a clear distinction between ordinary airline partnerships, what they call “marketing alliances”, and true strategic alliances:

“...Many US carriers are already involved in agreements with foreign airlines; however, only the most intimate of these relationships truly can be called strategic alliances... GRA defines strategic partnership or alliance to include *the commingling of airline assets*. The purpose of this distinction is to categorize a strategic alliance as a situation in which parts of each company join to pursue a single set of business objectives. This contrasts with contracts or other agreements established to fulfill dual objectives of the two companies involved. Commingled assets can be facilities, capital, or personnel. Common agreements such as interlining, codesharing, and even joint services do not commingle assets. Instead they are ‘marketing alliance’... Once two airlines present a common brand and set of services to the public, they also must commingle assets; this constitutes a true strategic alliance...”

If the concept of airline alliance is vague, the distinction between ordinary alliances and strategic alliances is even more diffuse. Nevertheless, concepts such as commitment, enduring relationship, long-term view, common goals, equal sharing of alliance benefits, and so on seem to be a constant element in what the industry understands by strategic airline alliances. Perhaps, the best way to identify strategic alliances would be to evaluate whether they constitute an essential part of the alliance members’ corporate strategy.

Here, strategic airline alliances will be considered as those *intercompany agreements between two or more airlines originated as a result of deliberate strategic thinking at top management level, and that, consequently, require a high degree of commitment by the alliance members in the coordination of certain activities for the achievement of an agreed set of common goals*. Even though this definition might continue to be diffuse, it should allow to distinguish between clear examples of strategic alliances, such as the

Star Alliance, and mere “marketing” or “transactional” alliances, such as codesharing practices on point-specific routes. Figure 1.1 illustrates schematically the differences between strategic alliances and marketing alliances.

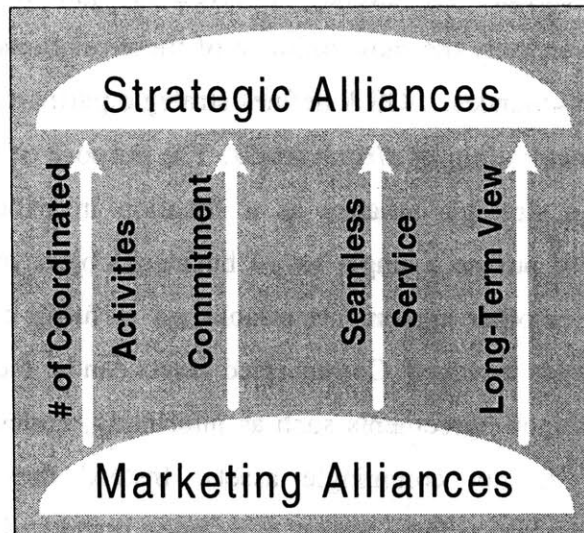

Figure 1.1. Distinction between marketing alliances and strategic alliances

As airline alliances enter the strategic dimension, coordination of activities among the alliance partners increases significantly. A clear indicator is the vast number of codeshare flights on partner operations found in strategic alliances, such as the KLM-Northwest partnership. Alliance members increase significantly their commitment to achieve a common set of goals, which is reflected, for example, in the emphasis on the promotion of the alliance “brand” through broad advertising campaigns. As marketing alliances evolve into strategic alliances, partners intend to offer a seamless service across the alliance network, sharing airport lounges and coordinating frequent flyer programs. Finally, strategic alliances look to the partnership with a long-term view, and therefore, spend significant resources dedicated exclusively to the alliance. Such is the case of new departments with full dedication to the coordination of alliance activities that are created inside the partners’ organizations.

The concept of strategic alliances is similar in many ways to the concept of mergers. However, mergers, takeovers, and acquisitions in which one firm assumes control of a

new entity are not alliances. As pointed out by Yoshino and Rangan (1995), the most important distinction between mergers and strategic alliances is that in the latter, “the two or more firms that make the agreement remain independent after the alliance is formed.”

1.3. The Concept of Codesharing

The US Department of Transportation (DOT) defines codesharing as “a common airline industry practice where, by mutual agreement between the cooperating carriers, at least one of the airline designator codes used on a flight is different from that of the airline operating the flight.”² In other words, one carrier puts its two-letter designator code on the flight operated by another carrier.

Codesharing is key in the development of airline alliances. It allows an airline to market air transportation service as its own in O&D markets where it does not operate or operates infrequently. As alliances are a mean for airline growth, codesharing is the principal tool used by alliances in achieving such goal. In fact, the use of codesharing has grown significantly faster in international operations, where airlines have limited access to foreign markets, and in regional operations, where major airlines lack the appropriate aircraft size to perform profitable operations, than in domestic operations.

Figure 1.2 illustrates a typical codesharing situation. It represents the case of a passenger flying from Chicago O’Hare (ORD) to Berlin (TXL) connecting at Frankfurt (FRA). The passenger has purchased a ticket from United Airlines; however, because United does not operate service from Frankfurt to Berlin, it offers a *codeshare flight* on the second leg of the route FRA-TXL that is operated by its partner Lufthansa.

² Cited in Wynne (1998)

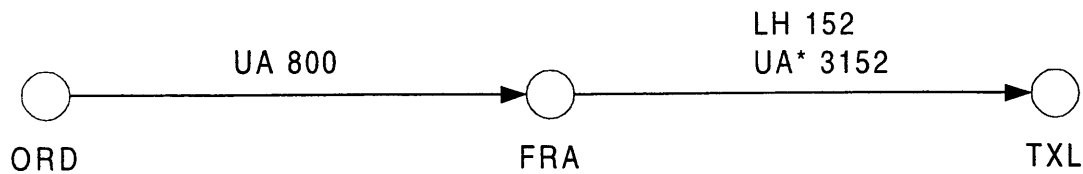

Figure 1.2. Typical codesharing situation on international markets

The ticket of the passenger flying with United Airlines will show two flight stages:

| | |
|----------|---------|
| UA 800 | ORD-FRA |
| UA* 3152 | FRA-TXL |

where the asterisk * to the right of the United designator code in the second stage indicates that such flight is *operated* by another carrier, in this case Lufthansa. In addition, Lufthansa will use its own designator code to market this same leg as LH 152. Consequently, there could be passengers flying on the same flight and showing different flight numbers and airline codes on their tickets.

The first codeshare flight occurred in 1967, when Allegheny Airlines (now USAir) let commuter carriers operate its non-profitable regional routes, but maintained its designator code on them (Oster and Pickrell, 1988). However, codesharing agreements did not extend beyond the Allegheny Commuter System until the US Deregulation Act of 1978, and they did not spread rapidly through the industry until 1984. These early codesharing practices were based on regional carriers acting as “feeder” networks for major airlines. Soon, codesharing was introduced on international routes, when American Airlines and the Australian carrier Qantas signed a codesharing agreement in 1985 (GRA, 1994). From the mid-1980s to the present time, the practice of codesharing has increased dramatically, along with the formation of alliances.

As will be discussed in subsequent sections, one of the main advantages of codesharing is that it allows a flight itinerary to be listed as an on-line connection (one airline) rather than as an interline connection (two or more airlines) on the screen of computer reservation systems (CRSs). Because the CRS algorithms that determine screen precedence give higher priority to on-line connecting itineraries than to interline

connecting itineraries, the alliance option will appear ahead of the interline itineraries of competitors on CRS screens.

Codesharing agreements take a large variety of forms in the industry. The details of each type of agreement are discussed in Chapter 4. Here, following the distinction made by Oum et al. (1996), a first differentiation between parallel and complementary codesharing is presented. This distinction depends on the network characteristics of the agreement, and is important in assessing the competitive impacts of each type of codesharing practice, since each of them affects demand and the competitive environment in different manners.

Parallel Codesharing

Parallel codesharing refers to codesharing between two carriers operating on the same route. There are two main purposes of parallel codesharing. First, the partnership can increase the apparent frequency offered by each airline to customers. Second, the partnership can rationalize capacity utilization by shifting aircraft resources from the codeshare route to more productive routes, while maintaining service in the codeshare one. Parallel codesharing can be used as a means of strengthening the market position of the alliance partners, as it will be discussed further in the chapter. Figure 1.3 illustrates parallel codesharing with an example.

Complementary Codesharing

Complementary codesharing refers to the codesharing practice where two carriers use each other's flights to provide connecting services over origin-destination (O&D) markets where they did not offer a full service on their own. Its main purpose is to increase the scope of the partners' networks, allowing them to supply service on markets where they did not operate before. This type of codesharing is highly related to the concept of *feeder networks*, where the network of one airline is connected to the network of another airline, acting as a "feed" of traffic. Figure 1.3 illustrates the complementary codesharing with an example.

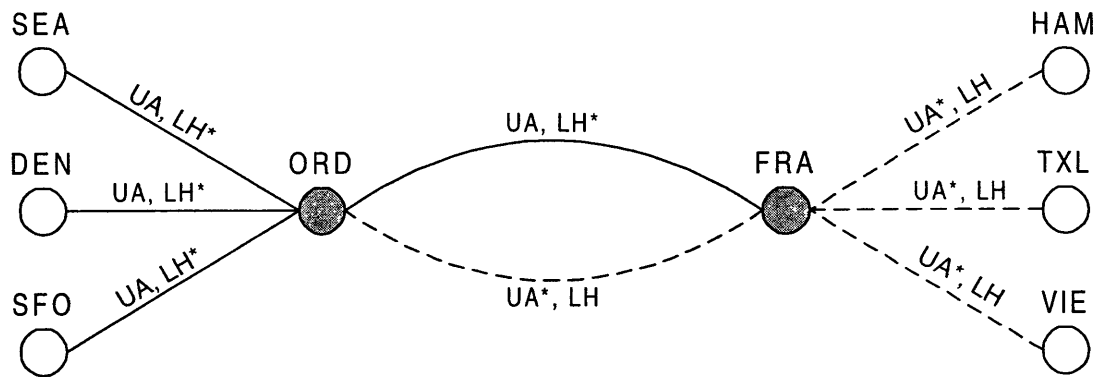

Figure 1.3. Parallel and complementary codesharing

In the above figure, the dashed lines represent flights operated by Lufthansa, while the straight lines represent flights operated by United Airlines. All the flights are being codeshared, so that the flights operated by United are marketed by Lufthansa as LH* flights, and the flights operated by Lufthansa are marketed by United as UA* flights. The codesharing practice on the transatlantic flight-leg ORD-FRA is parallel, since both airlines operate flights in this city-pair. By codesharing such flights, the alliance increases the apparent frequency offered to customers on the transatlantic link.

Both the codesharing practice by Lufthansa on the legs operated by United from its hub in Chicago (ORD) to Seattle (SEA), Denver (DEN), and San Francisco (SFO), and the codesharing practice by United on the legs operated by Lufthansa from its hub in Frankfurt (FRA) to Hamburg (HAM), Berlin (TXL), and Vienna (VIE) are complementary. Through them, United and Lufthansa increase the scope of their networks. That is, they increase the number of destinations that they offer to their customers as on-line service. The Lufthansa network can be seen as a “feeder network” for the United network in the case of US inbound traffic, and the United network can be seen as a “feeder network” for the Lufthansa network in the case of outbound traffic. Therefore, through codesharing both networks complement each other.

1.4. Airline Alliance Typologies

Since their specific characteristics have different implications on market structure and alliance management, it is important to distinguish the different types of airline alliances found in the industry. The characteristics of airline alliances differ depending on the extent to which the alliance members are involved in the partnership and the nature of the markets where they apply the agreements. Previous research has made several attempts to classify airline alliances. Here, three alternatives are presented; the first based on the scope of the alliance and the remaining two on the managerial aspects of the arrangement. Finally, other distinctions frequently found in the industry are also included.

1.4.1. The Scope of the Alliance

The US General Accounting Office (GAO, 1995), in reference to the different types of codesharing agreements, distinguishes three types of airline alliances: strategic alliances (referring to global alliances), point-to-point alliances, and regional alliances. Here, a fourth type of alliance that has developed in the late 1990s is included: the domestic strategic alliance.

Global Strategic Alliances

Under global strategic alliances, alliance partners enter into complex partnerships that involve codesharing on a vast number of routes. The scope of the alliance is international, as the two carriers involved in the agreement are from different countries and have significant international presence, though in most cases different coverage (for non-US airlines these carriers are generally the so-called “flag” carriers of each country). The main purpose of this type of alliance is to link the networks of the partners, complementing each other in the provision of competitive international air service. The alliance is intended to expand each partner’s network, creating a global network with wide coverage that offers seamless service to alliance customers. They usually involve a high coordination of numerous service-related activities, such as the

integration of flights, scheduling, frequent flyer programs, and advertising campaigns aimed to create brand recognition. Examples of this kind of alliance are the Northwest/KLM agreement, the United/Lufthansa agreement as part of the *Star Alliance*, the American/British agreement as part of the *Oneworld* alliance, and the Delta/Swissair agreement as part of the *Atlantic Excellence* alliance. Figure 1.4 represents schematically the integration of the partners' networks forming a global strategic alliance.

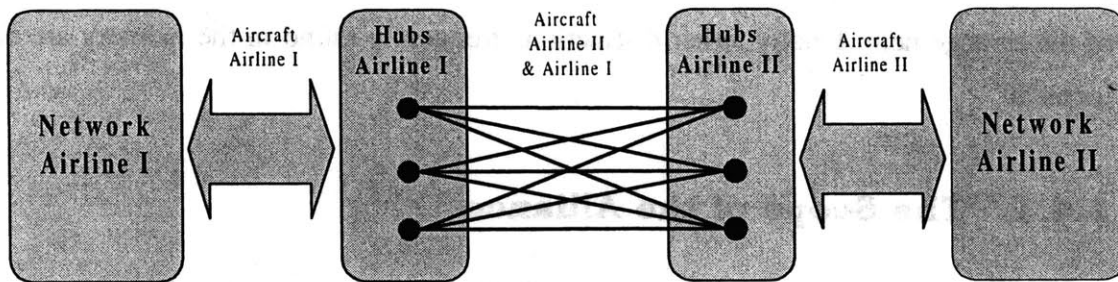

Figure 1.4. Network scheme of a global strategic alliance

Domestic Strategic Alliances

The concept of global strategic alliance can be translated from the international arena to the domestic arena to represent the recent agreements between major US airlines, such as the Northwest/Continental agreement, or the Delta/United agreement. The premise behind this type of alliances is the same as for global alliances, but at the domestic level. Airline partners seek to create increased domestic presence by integrating their schedules into a larger domestic network. The idea is that each network will complement that of the partner, though the degree of overlapping in this case is higher than in international alliances. While global alliances are based on complementary codesharing, domestic alliances are based on both parallel and complementary codesharing. Hence, antitrust regulators are starting to express their concerns about the impact of domestic strategic alliances on competition. Domestic strategic alliances expand the geographic coverage of the hubs across the combined alliance network, as is shown in Figure 1.5.

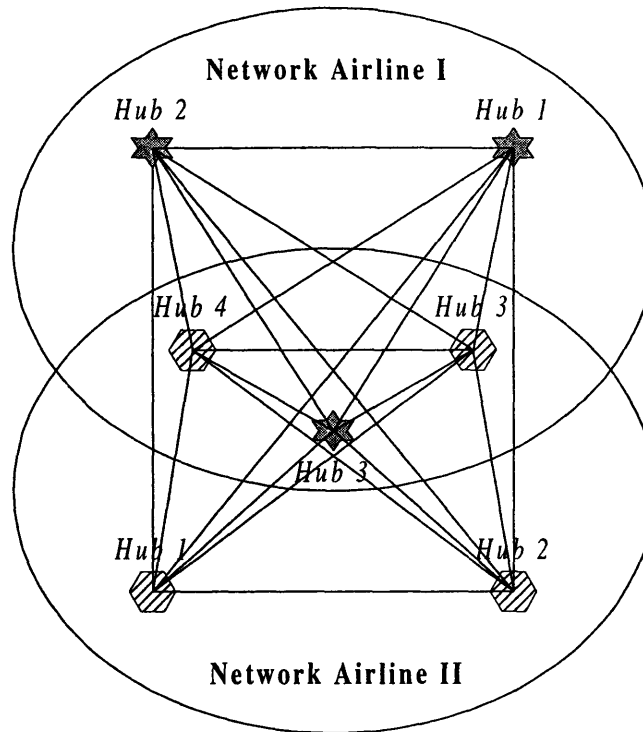

Figure 1.5. Domestic Strategic Alliance. Overlapping of networks

Regional Alliances

When the alliance involves codesharing and marketing agreements on several routes to and from a specific region, the alliance can be classified as regional. The premise behind this type of alliance is to have a regional carrier acting as a feeder for a major carrier's long-haul flights in a specific regional location, as well as the major's long-haul flights acting as feeders for the regional carrier's short-haul network. These alliances can be seen as a consequence of the US Airline Deregulation Act of 1978, when major carriers were forced to exit non-profitable low-density routes operated by their higher-density jets. Regional alliances may develop at both an international level and domestic level. In the latter case, the alliance represents in many cases a way of survival for the regional carrier by assuring a certain level of traffic connecting to the major's flights, and by taking advantage of the cost economies provided by the partnership. Figure 1.6 illustrates this type of alliance.

Regional alliances are a typical example of complementary codesharing, since both networks complement each other. Even though the term “strategic” has been used just for the first two alliance types, the regional alliance also falls within the definition given for strategic alliances. In fact, the formation of regional alliances with key commuter airlines as a way to feed the national and international routes of a major carrier constitutes in many cases an essential part of its corporate strategy. Examples of regional alliances at the domestic level are the agreements between American Airlines and the commuter carrier Mesa, or the Spanish international carrier Iberia and the regional carrier Air Nostrum. At the international level, examples are the agreements between United Airlines and British Midland, or British Airways and Deutsche BA. In some cases, regional alliances include the equity investment of the major airline in the stock of the regional carrier.

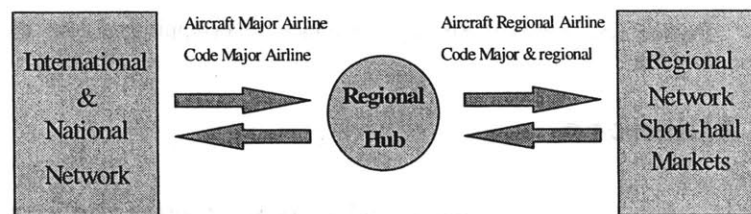

Figure 1.6. Regional Alliances. Share of complementary networks

Point-Specific Alliances

The point-specific alliance is the most common type of agreement found in the industry. Alliance partners get involved in partnerships that require little commitment in the coordination of alliance activities. Due to reasons of efficiency or market penetration, some airlines decide to get involved in agreements with other carriers to codeshare some flights in particular routes, as well as to extend the degree of coordination over traditional interline activities. Almost all major airlines in the world today are involved in some sort of point-specific alliance with other carriers. In fact, the majority of partners participating in global strategic alliances are simultaneously

engaged on multiple minor alliances of this type. Worldwide alliance surveys carried out by the magazine *Airline Business* in the years 1994, 1995, 1996 and 1998³ showed that all major airlines involved in global strategic alliances were simultaneously engaged in multiple point-specific alliances with other carriers.

Point-specific alliances occasionally include the coordination of schedules to ensure efficient transfer of passengers, baggage, or cargo, as well as simpler marketing arrangements such as the linkage of frequent flyer programs. The amount of coordinated activities and the degree of coordination vary significantly across the industry. One of the reasons for this heterogeneity is that, because point-specific alliances do not require high commitment from the partners, airlines seek to make such arrangements in a way that fits their diverse organic characteristics. A clear sign of such diversity of arrangements is the large spectrum of codesharing agreements found in the industry, in terms of revenue sharing and seat inventory allocation, or even more, the significant diversity of codesharing agreements between one same carrier and its different partners.

1.4.2. Stability and Structural Complexity

Rhoades and Lush (1997) propose a different approach to distinguish among airline alliances. They researched key alliance factors that could be used to predict the stability and duration of airline alliances. In particular, they identified two critical dimensions along which airline alliances differ: The complexity of the arrangement and the commitment of resources. Based on these two dimensions, they classified airline alliances into nine types, as presented in Figure 1.7 and described below:

Type I alliances are those involving simple marketing codesharing agreements, where one carrier merely puts its designator code on some flights operated by another carrier, but seat availability and all information related to the flight is controlled by the operating carrier as it would be for an interline connection. These agreements require

³ Surveys reported by Gallacher, J. in *Airline Business*, vols. 10(7), 11(6), 12(6) and 14(6)

little commitment of resources, since once reservation systems have been programmed for such a purpose the process is automatic. The complexity of the arrangement is low as well, since both carriers do not need to have significant management or operational interaction. *Type II* alliances are those involving more complex codesharing agreements where, for example, flight inventories are split into seat blocks among partners. Here, the degree of commitment is higher, since the alliance might lose revenue if the block spaces are not filled by either of the carriers. *Type III* alliances are the traditional agreements to share, invest in, or adopt computer reservation systems (CRSs). An example of this type of agreement is the CRS *Amadeus* shared by Air France, Lufthansa and Iberia among others.

| | | | | |
|--------------------------------|-----------------|--|---|---|
| Commitment of Resources | High | III. CRS | IV. Management Contracts | IX. Equity Governance |
| | Moderate | II. Sophisticated Codesharing Agreements | V. Joint Service | VIII. Joint Marketing |
| | Low | I. Simple Codesharing Agreements | VI. Insurance & Part Pooling | VII. Baggage Handlg. Ground Maint. Facilities Sharing |
| | | Low | Medium | High |

Complexity of Arrangement

Figure 1.7. Classification of different alliance types based on the complexity and commitment of arrangement. (Source: Rhoades et al. 1997)

Type IV alliances are those where the partners get involved in the joint purchase of parts and insurance. *Type V* alliances are those where partners have complementary route structures and join their services to offer a higher scope of service. *Type VI* alliances imply that one group of trained individuals will be responsible for, and dedicated to a

portion of the alliance. *Type VII* alliances involve partners with similar routes that have the ability to work together in providing baggage handling and ground maintenance so that the operations of both airlines can run smoothly. *Type VIII* alliances involve the marketing of their joint service through advertising campaigns that emphasize the size and scope of the alliance network. Finally, *Type IX* alliances involve the participation of one or both airlines in the board governance structure of the partner airline.

Rhoades and Lush propose that alliance stability increases with commitment but decreases with complexity, due to the rise of management and decision-making frictions. They justify their argument on the several interairline agreements that were analyzed in their study. Figure 1.8 illustrates their proposition.

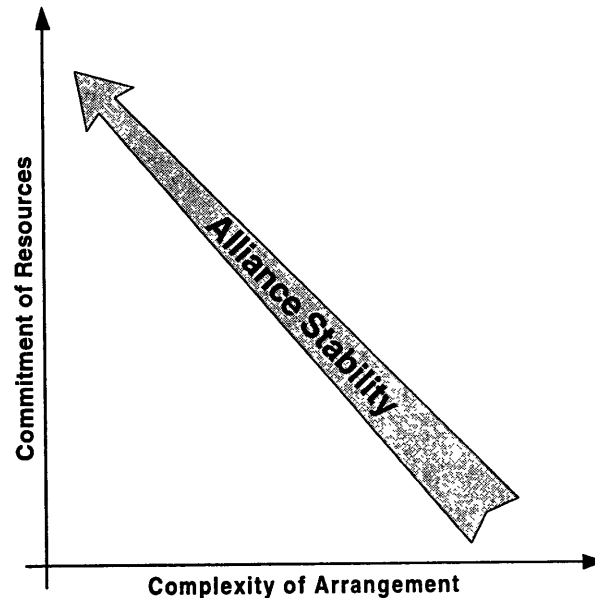

Figure 1.8. The stability matrix for airline alliances
(source: adapted from Rhoades et al. 1997)

The classification presented above is comprehensive, but does not take into account the fact that airline alliances involve many of these activities simultaneously in most of the cases. Therefore, it becomes extremely difficult to classify an airline alliance under just one of the nine types presented. The classification proposed by Rhoades and Lush, consequently, is more appropriate for qualifying activities being shared within alliances, rather than alliances as a whole.

Nevertheless the concepts and the two-dimensional analysis introduced by Rhoades and Lush could be extremely useful as a tool to evaluate the convenience of potential partnerships, and to help make strategic decisions regarding the selection of the appropriate partner.

1.4.3. The Three-Stage Evolution

Freidheim (1998) considers the international strategic alliance developing in three stages until it reaches what he defines as the relationship enterprise, which represents the ultimate state of intercompany collaboration. As alliances evolve through such development process, they can be classified as belonging to each of the evolution steps.

Single-Purpose Alliances (Stage 1)

In the words of Freidheim, “finding that they cannot continue to go it alone, companies build more and more linkages with other firms to bridge traditional geographic and value-added boundaries”. It is a first approach to intercompany collaboration, and could easily be related to the point-specific alliances introduced in Section 1.4.1. “Companies look for new ways to cooperate among them, in search of synergies that will improve their competitive positions.” The airline industry entered broadly this stage of the alliance evolution in the mid-1980s, when multiple codesharing and interairline agreements started to develop in the international arena. Still today, many airlines are engaged in agreements of this type, as new and uncertain partnerships are formed.

Network of Partners (Stage 2)

“Airlines begin to recognize the opportunities that broader and deeper involvement with their partners might offer, as they add more capabilities and enter new markets. Alliance members become more comfortable working together; communication becomes easier, trust builds, and the common agenda evolves. Partners extend their relationships to include technology sharing, cross marketing, and even common investments.” Freidheim identifies three key characteristics of these types of alliances:

They have common systems and standards, They have shared goals and strategies, and they have shared values and trust.

Many airlines today are involved in alliances at this evolution stage. Examples are the global strategic alliances cited in Section 1.4.1, such as the Northwest/KLM partnership, the Star Alliance, or the Oneworld Alliance, many of them involving equity investments in the partners' stocks.

Multiple Partners Acting in Concert (Stage 3)

At this stage, the partners recognize their potential power and begin to act together as a single company. "The values, goals and systems have been aligned, and the alliance is embarked on a direction for which the combined energies, resources and capabilities of its members is required. A relationship enterprise will act more like a political federation than a business alliance. Each participating company will have its own agenda and objectives, which it will pursue independently. Each will have shareholders and other stakeholders whom it must satisfy. However, each will lend its full power to the enterprise."

There is no present airline alliance at this stage. However, the increasing interairline coordination, commitment and one-global-network emphasis found between several partners of global alliance groups (such as AA/BA in the Oneworld, UA/LH in the Star Alliance, or NW/KLM) could be seen as an attempt by certain airlines to reach this final stage of the alliance evolution. The trend towards the relationship enterprise makes us predict a future structure of the industry concentrated in few gigantic alliance groups. This could be the case of the already formed Star Alliance or the Oneworld.

1.4.4. Other Alliance Distinctions

In this section, a series of alliance classifications that are frequently used in the airline industry are included. Particularly, two additional alliance distinctions are presented: The distinction between transactional and strategic alliances, already addressed in Section 1.1, and the distinction between equity alliances and non-equity alliances.

Transactional Alliances versus Strategic Alliances

Section 1.2 highlighted the differences between simple alliances and strategic alliances. The firsts can be found under different names such as transactional alliances, marketing alliances, or just simply alliances. They are established for a specific purpose, typically to improve each member's business in some aspects. In contrast, strategic alliances have a higher level of commitment, shared resources, and common goals. This distinction is frequently used in the airline industry.

Equity Alliances versus Non-Equity Alliances

Equity alliances are those in which alliance members enter into agreements that involve an exchange of equity between them. These investment represents a sign of each member's interest in "making certain that the marketing and operating agreements that define the alliance are effective and successful" (GRA, 1994). They are intended to support the most advanced and durable form of alliance, providing to each carrier incentive to continue and promote the agreement.

Equity alliances can be further divided into unidirectional-investment and bidirectional-investment alliances (Oum and Park, 1997). In the first case, only one carrier makes an investment in the partner's stock. Examples of this type of alliance are/were the BA/USAir, BA/Iberia, or AA/Canadian partnerships. In the bidirectional investment case, there is an exchange of equity shares among both alliance members. An example of this type of equity alliance was the Delta/Swissair/Singapore alliance. Oum and Park found that "unidirectional-investment alliances tend to be somewhat fragile, because

usually the investor airline attempts to exercise control over the carrier in which it made the investment.” The BA/USAir alliance is a clear example of the friction created by BA’s exercise of control on USAir.

1.5. Motivations for Airline Alliances

Chapter 2 elaborates in detail the economic impact of airline alliances, and with them, a comprehensive list of the advantages derived from partnering with other carriers. This section, however, provides a first set of factors to help understand the motivations behind airline alliances, focusing on those industry drivers that historically have motivated their development. Then, the implications of airline alliances on airline corporate strategy are introduced. A strategy framework is established to illustrate the way alliances help airlines achieve their goals, becoming *strategic weapons*.

The recent history in the economies of developed countries presents a clear trend towards consolidation among companies within and across industries. Globalization and internationalization are two of the major industrial trends of the late twentieth century (Thurow, 1996). In the second half of the twentieth century, companies have concentrated into large entities that control significant portions of their domestic industries. Once converted into major national players, these large corporations have started to expand internationally. And it is in their intent to compete internationally that alliances have come to play.

Because there are *advantages of size and market coverage*, companies have experienced a “need” to grow and to have a presence in a large number of markets. Other structural economies in addition to the classical concept of scale economies, as well as the need to meet increasing customer demand for a global product and/or service, represent the main drivers behind the need for growth experienced by corporations in the twentieth century. Every industry manifest different characteristics in the way companies benefit from growth, which makes the motivations behind such company growth differ from industry to industry and from company to company.

The advantages derived from size and wide market coverage have become increasingly important as trade boundaries have been relaxed and the development of communications has accelerated. The managerial movement in favor of the *global corporation* experienced in the 1990s is a clear sign of how important it is for a successful modern company to expand its coverage globally. “One of the most trumpeted developments in corporate organization and strategy in the 1980s and early 1990s has been the global corporation” (Freidheim, 1998), a fact that illustrates how significant to focus globally has become from a business perspective.

Moreover, the increasing importance of the advantages derived from size and wide coverage has forced company expansion to become a necessity rather than a goal in some industries and for some companies, with the exceptions of niche players. This could be exactly the case of the airline industry, which undoubtedly operates in a global marketplace, global economy, under global management and under global citizens. The GRA (1994), referring to codesharing alliances, is clear about the importance of having a wide market coverage in the airline industry: “The major long-run goal of codesharing is to secure a place in the international marketplace, and airlines with no codesharing partners risk being left out of this marketplace.”

Youssef (1992) explains the motivations for airline growth in terms of the structural economies that it can provide. He distinguishes among cost economies, which result in lower operating costs, and service economies, which in turn lead to improved product quality. Cost economies can be distinguished into economies of scale, economies of scope and economies of density. Chapter 2 will further elaborate on such concepts within the context of airline alliances.

In the airline industry, however, is not so much the size as it is the market coverage and network density that provides competitive power to a carrier. Several studies, including that of White (1979), have found no evidence that higher production levels—in terms of available seat miles (ASMs), for example—lead to lower unit production costs, “yet perceptions concerning the existence of economies of scale in production might motivate airlines to grow” (Youssef 1992). Nevertheless, increased market coverage

and network density requires company growth, although the contrary does not hold. Here, the concept of *feeder network* plays an important role in the airlines' motivations to expand market coverage. Airlines seek to partner with other carriers operating complementary networks that will act as "feeders" for their own networks and, in turn, provide economies of density.

In conclusion, one of the key drivers that explain the actions taken by the different players in the airline industry is the search for wider market coverage. Thus, the next step in the discussion is to analyze how alliances can allow airlines achieve such a goal.

It is important to make a clear distinction between market coverage and geographic coverage. Market coverage refers to the number of different origin and destination markets being served by an airline, while geographic coverage refers to the number of different regions being served. For example, one airline might have a wide geographical coverage by serving different destinations of the world and, however, have smaller market coverage than an airline serving only US markets, but all of them.

Basically, there are two ways for an airline to expand its market coverage. First, airlines can expand through company growth, which can be internal or based on mergers and acquisitions with other airlines. Second, airlines can expand through the formation of alliances with other carriers. Thus, this is the main motivation for the formation of alliances: Airline alliances are a main consequence of the airline desire to increase market coverage. Whether company growth or the formation of alliances represents a better option is the next point to be addressed.

Internal growth is unrealistic in most of the cases because of the enormous financial costs required to support a network with large coverage. Consequently, mergers, acquisitions and alliances represent the more feasible alternatives. Mergers and acquisitions have been predominant in the 1970s and 1980s, while relationship enterprises have become dominant in the 1990s, leading the way for the development of alliances fundamentally in the international arena (Yoshino and Rangan, 1995).

Freidheim (1998) found seven main reasons that companies choose alliance over acquisition when expanding themselves:

1. **Risk Sharing.** Companies cannot afford the potential downside of the investment opportunity alone.
2. **Acquisition barriers.** Companies cannot acquire the right partner because of price, size, unwanted business, government resistance, reluctance of owners, or regulatory restrictions.
3. **Market-segment access.** Companies do not understand the customers or do not have the relationships or infrastructure to distribute their products and/or services to a particular market.
4. **Technology gaps.** Companies do not have all the technology they need and cannot afford the time or resources to develop it themselves.
5. **Geographic access.** Companies are not where they want to be and do not have the resources to get there.
6. **Funding constraints.** Individual companies cannot afford developing or launching the venture alone.
7. **Management skills.** Companies need more talent to be successful.

Even though these seven reasons refer to corporate alliances in general, they fit well within the context of airline alliances. The fact that internal growth as a means of expanding network coverage is financially unfeasible in most of the cases justifies the first reason. The second and fifth reasons—barriers to entry into foreign countries and geographic access to markets—are critical in the formation of international airline alliances. Here, the prevailing political and regulatory situation of international aviation, which limits mergers and acquisitions carried out by carriers on foreign countries, leaves in many occasions alliances as the only feasible way to enter new markets. The third reason is also key for international alliances, though can be applied to regional alliances as well due to the differences in service between commuter and domestic air travel. The remaining three reasons apply to airline alliances in many cases, although they are usually not as critical as the other four.

In the US airline industry, the 1970s and 1980s were the years in which some national carriers were consolidated into major airlines. These consolidations represented airline growth through mergers and acquisitions. However, in the late 1980s and 1990s, when major airlines were already consolidated and started to expand internationally, alliance development became the main vehicle for the expansion of network coverage. In addition, at a regional level, airline alliances started to develop as well, generally involving a major airline and a commuter carrier.

It seems clear that the formation of airline alliances has occurred primarily between airlines with fundamental structural differences. In the regional alliance, such differences arise from the operational and service disparities between the commuter and the domestic air travel. Disparities related to fleet, crew, and management requirements. In the international alliance, however, the differences arise from legislation, culture or simply geographical location. An exception is the case of the recently formed strategic domestic alliances, which do not present such a clear structural difference among the carriers involved. This type of alliances can be seen more as a consequence of antitrust law limitations, as discussed below.

Governments play an important role in the formation of alliances. Antitrust legislation may prevent airlines from merging or carrying out acquisitions because of competition concerns, while it might allow them to form alliances. This is the case of the proposed domestic strategic alliances in the US. In the international arena, most governments limit the amount of foreign equity over national carriers, and therefore, the formation of alliances represent the only alternative for foreign carriers to enter such markets.

In light of all that has been discussed above, airline alliances can be seen as a fundamental tool used by airlines pursuing to increase their presence in the global marketplace. However, airline alliances produce additional benefits for the airline members that can be equally critical for their competitive positions. In fact, airline alliances have become so critical in the airline industry that they constitute an essential element in the strategy formulation of most airlines today. In Figure 1.9 below, a strategy framework that illustrates the author's interpretation of the role of alliances in

helping airline members achieve their corporate goals is provided. Alliances represent *strategic weapons* for the participating airlines within an alliance.

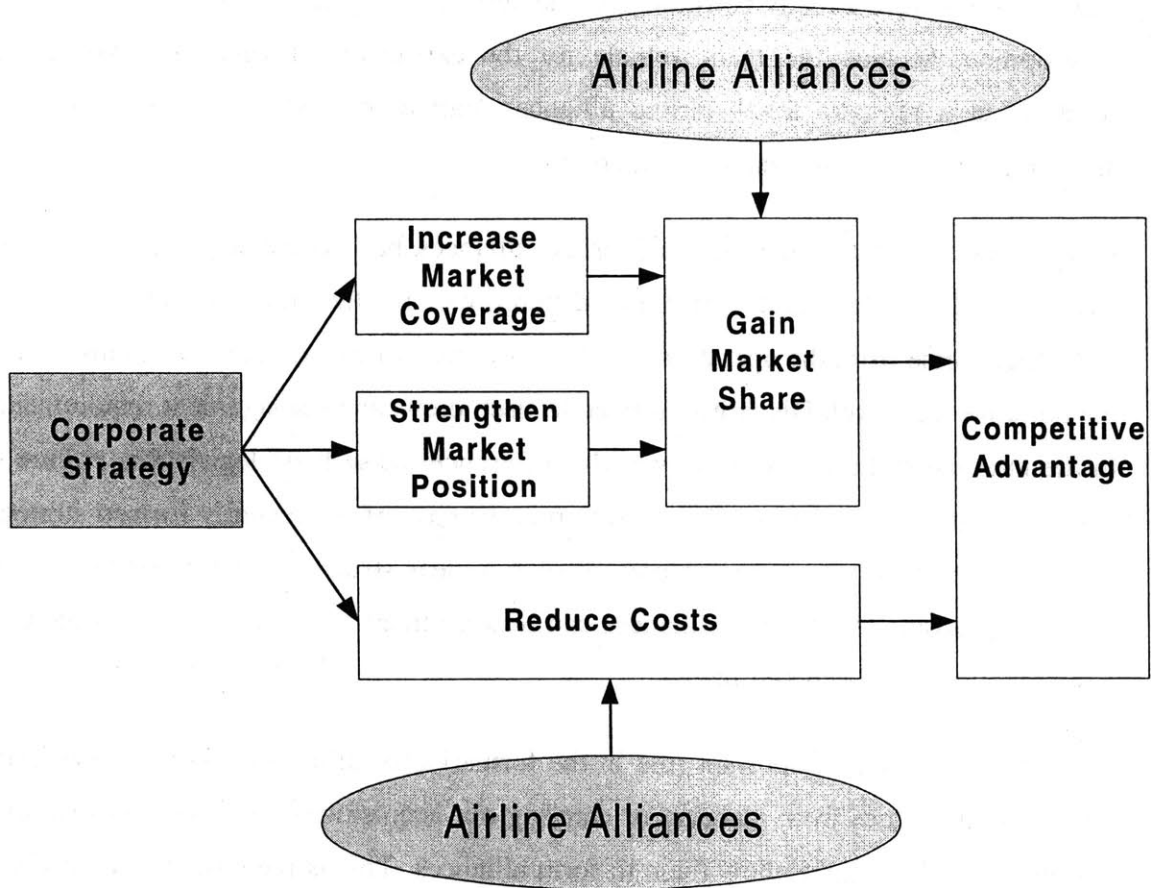

Figure 1.9. Airline alliances as strategic weapons

In addition to help increase the market coverage of its members, alliances allow airlines to strengthen their market positions in certain routes, and to achieve cost reductions. Chapter 2 will further elaborate on the ways airline alliances provide such benefits for the airline members. Because the increase of market coverage, the strengthening of market position, and the cost reductions achieved through the alliance represent for its members significant sources of competitive advantage, there is no doubt that alliances have become an essential element in the corporate strategy of today's airlines.

1.6. Trends in Airline Alliances

1.6.1. Alliance Evolution

“Historically, international alliances can be traced back as far as 1945, when IATA was established primarily to coordinate international air fares” (Button, 1997). After the 1944 Chicago Convention, bilateral agreements were established between governments, who owned or were directly responsible for the operation of their national carriers. These inter-government agreements for the provision of air service by their “flag” carriers represented the first form of airline alliances. In the late 1980s and early 1990s, however, new forms of international alliances developed; alliances that embraced somewhat different characteristics and served different purposes.

Such alliances “have been less institutionalized in that they have been generally formed by business-oriented commercial airlines outside of any governmental or inter-governmental agency initiative” (Button, 1997). Alliances today can imply some degree of equity ownership of one carrier by another, but they often imply broader agreements for collaboration amongst partners. Collaborations that imply the coordination of different activities, such as codesharing, scheduling, joint marketing, or any of the activities mentioned in Section 1.2. Equally, airlines “have become involved in a large number of different alliances, some embracing a single carrier, but others involving several carriers” (Button, 1997).

Domestic Alliance Evolution

The first codesharing agreement occurred in the US in 1967, when Allegheny Airlines (now USAir) shifted from propeller to jet aircraft in that year. The large jets acquired by Allegheny Airlines were uneconomical to operate on certain low-density routes traditionally operated by the airline; however, the Civil Aeronautics Board (CAB) would not allow Allegheny Airlines to stop providing service on such markets. Consequently, Allegheny Airlines formed a series of “agreements under which various commuter carriers agreed to take over service from major cities to small communities,

with those commuter carriers' flights identified by Allegheny's designator code" (Oster and Pickrell, 1988). This codesharing agreement represented the first form of domestic airline alliance, and its main purpose was not to provide market access, as it is the case today, but to provide replacement service.

However, the real development of airline alliances took place after the US Airline Deregulation Act of 1978. US airlines experienced the need to rationalize their operations and increase efficiency in order to be competitive. They shifted their network structures from a direct-flight scheme to a hub-and-spoke scheme, gaining economies of density. National carriers consolidated into large domestic airlines and focused on medium and long-haul markets, using medium and large-size jets, while commuter carriers concentrated in focal regions using small aircraft (most of them propeller aircraft), becoming feeders for the networks of larger domestic airlines. It was in the mid 1980s that major carriers realized the benefits from controlling their commuter feeder networks and started to form codesharing contracts with regional carriers, triggering the evolution of modern regional alliances. Since then, "major airlines have added more commuter partners and have marketed their services under the major carrier's name by creating brands such as the Delta Connection and USAir Express" (GRA, 1994).

Recently, in the late 1990s, major US airlines have sought to reinforce the market coverage and hub dominance of their national networks by forming domestic strategic alliances with other major airlines. That is the case of the Delta/United and Northwest/Continental proposed alliances.

International Alliance Evolution

In the international arena, traditional US domestic Airlines started to expand their service to foreign countries. Mainly because the access to foreign markets was restricted by the then unregulated aviation policies of such countries and the high financial costs of establishing operations abroad, US airlines started to form international codesharing agreements with foreign carriers. The first international

codesharing agreement was signed by American Airlines and Qantas in 1985 (GRA, 1994), triggering the evolution of modern international airline alliances. These initial partnerships were point-specific. Soon, airlines realized the advantages of expanding their hub-and-spoke network structures to the international marketplace, forming multi-hub transcontinental networks. The premise behind such multi-hub networks was that complementary networks would feed each other's traffic through inter-hub connections. However, due to international regulation, controlling and operating a hub in a foreign country was not feasible. Consequently, airlines started to form broad codesharing alliances with foreign carriers that had strong domestic networks, in an effort to create multi-hub global networks. This action was the beginning of international strategic alliances. Examples are the NW/KLM and the BA/USAir partnerships formed in the early 1990s.

Carriers that lacked strong domestic networks were less attractive as alliance partners. In fact, having a strong domestic network became a necessity not only from an alliance point of view, but also from a survival perspective. Strong domestic networks that would support one carrier's international flights became a key factor when competition translated to the international marketplace, and carriers traditionally focused on domestic markets started international operations. US carriers such as Trans World Airlines (TWA) and Pan American, for example, were traditionally focus on international operations and lacked strong domestic networks. Consequently, they had a hard time "feeding" their international flights after deregulation. In fact, it could be argued that it was mainly as a consequence of such lack of supporting domestic networks that Pan American went bankrupt in 1991.

These international strategic alliances started taking the form of equity alliances, where carriers entered into agreements that involved an exchange of equity between them. That is the case of the BA/USAir or NW/KLM partnerships, formed in the early 1990s. However, more recent international strategic alliances have developed as pure commercial agreements, as it is the case with the UA/LH and the AA/BA partnerships.

In general, European carriers have tended to be involved in equity alliances more frequently than North American and Asian carriers (Park, 1997).

The Role of Governments

Governments have played a critical role in the evolution of airline alliances. In the US domestic market, the Department of Transportation (DOT) first limited the potential for further mergers among major domestic carriers, and recently has been monitoring the competitive implications of proposed domestic strategic alliances. However, it is in the international arena where government intervention has been especially critical. Below, a summary of the government policies towards international airline alliances presented in Park's dissertation (1997) is provided.

Until December of 1987, the DOT had a generous policy toward allowing international codesharing agreements. It did not require approval proceedings as long as both US and foreign carriers had underlying route authority to the cities involved (Hadrovic, 1990). However, after United Airlines and British Airways proposed a codesharing agreement in December 1987, the DOT decided to require any codesharing alliance involving US carriers to obtain DOT authorization. It declared that an international alliance would not be approved by the DOT unless it was covered in a bilateral agreement or otherwise brought benefits to the US, and unless the foreign country allowed US carriers codesharing rights in its markets (GRA, 1994).

Approval of international alliances has been used to change some aspects of existing bilateral agreements. An example is the British Airways/USAir partnership, formed in 1993. As the UK insisted on having codesharing authority in US domestic markets for British Airways, the DOT authorized the alliance in exchange for a bilateral agreement so that United Airlines and American Airlines could operate into London Heathrow. Recently, antitrust immunity by the US government has been granted to certain international alliances as a means to secure open skies agreements. That is the case of the NW/KLM and LH/UA partnerships, which were granted antitrust immunity after the US obtained open-skies agreements with both the Netherlands and Germany.

In the European Union, unlike in the US, there are no approval proceedings required for international codesharing within the Union, and virtually any European carrier is allowed to form alliances unless they suppose a threat for competition. Individual EU states have different perspectives with respect to codesharing on intercontinental operations. While UK and the Netherlands, for example, have never objected to codesharing agreements, claiming that a codesharing operation should be a marketing right rather than a traffic right, Italy prohibits codesharing operations on fifth freedom routes unless specified in a bilateral agreement.

1.6.2. Recent Alliance Trends

Table 1.1 and Figure 1.10 provide the figures of the alliance growth experienced by the airline industry in the last 4 years. As the graph shows, the number of alliances has followed almost an exponential growth with an estimated average annual growth rate of 15.7%. It has grown from 280 alliances in 1994 to 502 in 1998. Equally, there has been 60 new airlines joining the alliance trend during that period. In 1998, the two airlines involved in the largest number of alliances were American Airlines with 26 alliances and Air France with 28. These figures do not include regional carriers or alliances restricted to the coordination of frequent flyer programs.

Table 1.1. Airline alliance growth during the years 1994-1998

| | 1994 | 1995 | 1996 | 1998 | % Change 1994-1998 | Average Annual Growth Rate ¹ |
|----------------------------|------------------|------|------|------|-----------------------|--|
| Number of alliances | 280 | 324 | 389 | 502 | 79.3% | 15.7% |
| With equity stakes | 58 | 58 | 62 | 56 | -3.4% | -0.9% |
| Without equity | 222 | 266 | 327 | 446 | 100.9% | 19.1% |
| New alliances | n/a ² | 50 | 71 | 121 | N/a | n/a |
| Number of airlines | 136 | 153 | 171 | 196 | 44.1% | 9.6% |

Source: Airline Business surveys of years 1994, 1995, 1996 & 1998

¹ Estimated between 1994 and 1998 as $(1998\text{-figure} / 1994\text{-figure})^{0.25} - 1$

² n/a: Not available

Even though alliances have grown significantly, the number of equity alliances has remained approximately constant over the period 1994-1998. As equity investments represent further steps in the consolidation of alliances and involve higher levels of commitment among alliance partners, airlines are cautious about their formation.

However, several industry trends indicate that equity would remain to be a critical factor as a means to cement alliances. Examples are Swissair's plan to take up to 20% of TAP, American's stake in Aerolineas Argentinas and Iberia, British Airways' recent investment in 9% of Iberia, Delta's 30% of Aero Peru, and Northwest's investment in Continental.

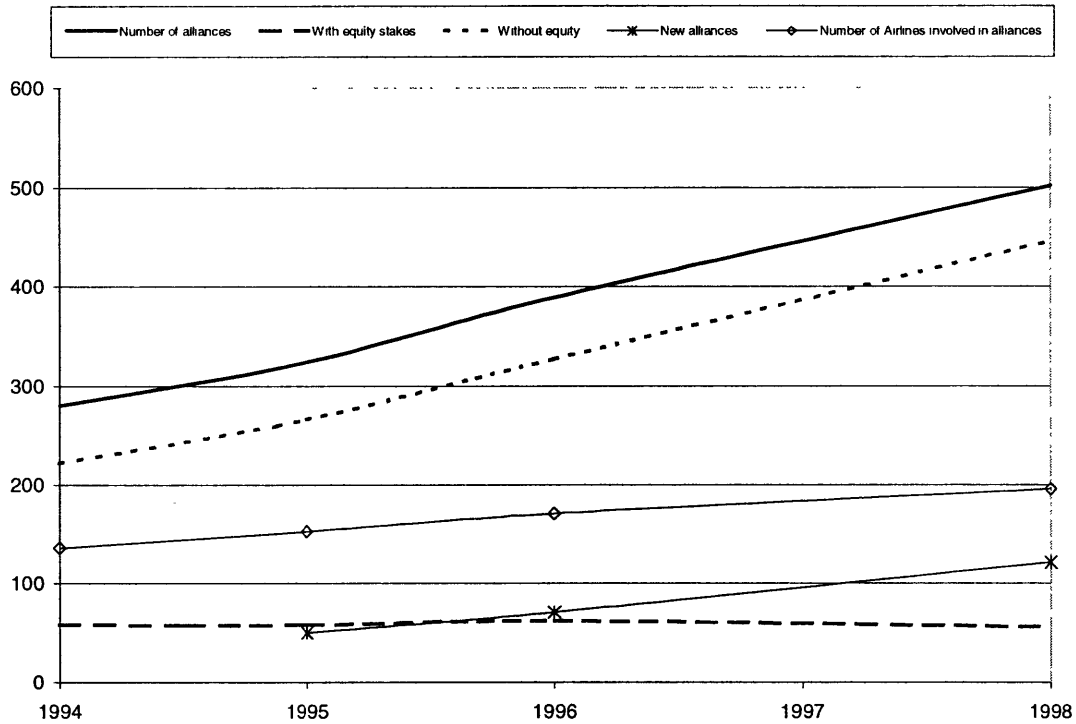

Figure 1.10. Alliance growth during the period 1994-1998

In 1995, the Boston Consulting Group (BCG) reported an airline alliance study to the British Government in which the impact of every type of alliance on its survival rate was analyzed⁴. The BCG found that alliances involving equity investments appeared to have a higher survival rate compared to those without equity. Table 1.2 presents the survival rates found by the BCG. They also found that intercontinental alliances were more likely to break down than regional international alliances, which in turn were more likely to break down than domestic alliances. In 1998, the BCG reported a second

⁴ BCG (1995): *The Role of Alliances in the Strategy of Airlines*, London. Cited in ICA, 1997

study⁵. Their main findings were that airline alliances were more likely to survive then, in 1998, than they were in 1995. 68% of the alliances analyzed in their study survived the 1995-1998 period, nearly double the survival rate for the 1992-1995 period. In addition, the BCG reported that the survival rate of alliances is more dependent on the level of integration achieved than on the equity involved. This trend is opposite to that shown for the previous survey period, where equity was more likely to indicate the chances of alliance survival.

Table 1.2. Survival rates for international alliances, 1992-95

| | Without equity (%) | With equity (%) | Overall survival rate (%) |
|-------------------------|--------------------|-----------------|---------------------------|
| Intercontinental | 23% | 77% | 33% |
| Regional | 36% | 80% | 59% |
| Domestic | Na | 65% | 65% |
| Overall rate | 26% | 73% | Na |

Source: ICA, 1997. Compiled by the BCG, 1995

Airline alliances involve the coordination of numerous activities among partner airlines. Park (1997) investigated 46 alliances in order to identify the current areas of joint activities found in the industry. His findings are summarized in the table below.

Table 1.3. Areas of coordinated activities within airline alliances

| | Point-specific alliances | Broad Commercial alliances | Equity alliances |
|--|--------------------------|----------------------------|------------------|
| Coordination in ground Handling | 18% | 78% | 100% |
| Joint use of ground facilities | 46% | 100% | 100% |
| Shared frequent flyer programs | 32% | 100% | 67% |
| Codesharing or joint operations | 89% | 100% | 100% |
| Block space sales | 36% | 44% | 33% |
| Coordination of flight schedules | 14% | 100% | 100% |
| Exchange of flight attendants | 4% | 22% | 56% |
| Joint development of systems | 4% | 22% | 33% |
| Joint advertising and promotion | -- | 33% | 44% |
| Joint maintenance | -- | -- | 11% |
| Joint purchasing of aircraft/fuel | -- | -- | 44% |
| Number of alliances | 28 | 9 | 9 |

Source: Park, 1997

⁵ Reported in "BCG Report Claims US Airline Alliances Stronger than Four Years Ago", *Airline Industry Information*, M2 Communications, 1999

Broad commercial alliances and equity alliances can be considered as strategic alliances. The figures observed by Park reveal that strategic alliances are involved in a larger number of activities than point-specific alliances. This result was expected, since the latter are often meant to improve just a particular aspect of the airline members. The two activities most commonly coordinated within the alliances analyzed in his study were the joint use of ground facilities and the codesharing of flights. Strategic alliances put high emphasis on the coordination of additional activities that affect the strategic success of the alliance, such as the coordination of flight schedules—the coordination of flight schedules is further discussed in Chapter 3. In general, the higher the commitment required from the airline partners in the coordination of an alliance activity, the more likely the activity will be coordinated under an equity alliance.

Current Major Alliances

Strategic alliances currently playing a role in the globalization of the skies are found in four major groupings of airlines, which are listed below⁶.

Star Alliance. The Star Alliance is the global airline network formed by United Airlines, Air Canada, Lufthansa, SAS, Thai Airways International and VARIG. In 1998, it had 1,446 aircraft serving 654 destinations in 108 countries. Air New Zealand and Ansett Australia have recently entered into the consortium in March 1999, while All Nippon Airways is expected to join the group in October 1999. Singapore Airlines and South African Airways are considering joining the alliance as well. It will have some 2,000 aircraft serving nearly 900 destinations when pending applicants are admitted, becoming the largest alliance. Star has a seamless frequent flyer program and many shared facilities around the world.

Oneworld. Oneworld is the global airline network formed in 1998 by American Airlines, British Airways, Canadian Airlines, Cathay Pacific and Qantas. By the end of 1998, it had 1,524 aircraft serving 632 destinations. Iberia has recently entered the

⁶ Information compiled from the airlines' web-sites, *Airwise News*, *Airline Business*, and several other publications or news-reports.

alliance in February 1999, Finnair is expected to become a full member of the alliance by the end of 1999, and Japan Airlines is in negotiations. The group offers a seamless frequent flyer program and shared facilities worldwide. BA owns 25% of Qantas, owns 9% of Iberia, is awaiting approval to link with American, and both BA and Qantas are interested in taking a small stake in Cathay. Oneworld may become more closely knit than other alliances where cross-equity is not involved.

Atlantic Excellence. Formed by Austrian Airlines, Delta Air Lines, Sabena, and Swissair. In 1998, it had 700 aircraft serving over 400 destinations. It was among the first alliances to harmonize fares. It has some shared facilities and is pursuing to consolidate at key destinations. Its greatest weakness is the lack of an Asian connection, after Singapore Airlines broke its relationship with the Atlantic Excellence to join the bigger Star Alliance. It is currently in negotiations with Korean Airlines.

KLM/Northwest. Is the oldest strategic alliance, and was born out of KLM's investment in Northwest when the latter was facing strong financial pressure at the end of the 1980s. Although KLM has already sold its stake in Northwest, the two carriers maintain a close marketing alliance. They share airport lounges and engineering and maintenance facilities worldwide. Their *Worldperks* frequent flyer program is the oldest joint program. They lack an Asian partner, although they are in negotiations with Malaysia Airlines. In Europe, Alitalia is considering joining the partnership.

Chapter 2

Economic Impacts of Airline Alliances

2.1. Introduction

In this chapter, the results of a literature review carried out as an attempt to identify the implications of airline alliances for the industry and its stakeholders are presented. The aim of this chapter is to provide a comprehensive overview of both the positive and negative impacts alliances bring to the airline industry. The chapter will try to provide answers to frequently raised alliance-related questions; questions such as: Are airline alliances beneficial for the airlines? To what extent and for which type of airlines are they beneficial? Do they provide the same benefits to passengers? What are the advantages and disadvantages of airline alliances?

In Chapter 1, the concept of airline alliances was introduced, as well as the main motivations behind them. Here, such motivations are further studied, grouping the entire spectrum of alliance implications into positive and negative impacts, both for the airlines participating in the alliance and the rest of stakeholders.

The economic impacts of airline alliances are highly related to the nature of each individual alliance, and are difficult to generalize to the different types of alliances found in industry. This chapter identifies the different impacts of alliances focusing primarily on international alliances. Once potential implications are identified, empirical evidence obtained through previous research studies or the research of this thesis is provided. Section 2.2 summarizes the impacts of alliances on the participating airlines, while Section 2.3 summarizes the impacts on the rest of the stakeholders. In each case, a “*positive-and-negative impacts*” approach has been used.

2.2. Impacts on the Participating Airlines

2.2.1. Positive Impacts

As alliances are increasingly common in the airline industry, the advantages airlines attempt to achieve through alliances are becoming integral elements of their corporate strategy. In Chapter 1, airline alliances were highlighted as powerful strategic tools for the furtherance of their partners and the gain of competitive advantage. Here, following the strategic framework given in Section 1.5, the three most commonly quoted motivations for the formation of alliances are identified:

- Increase passenger traffic (and therefore revenues)
- Reduce costs
- Strengthen market position against competitors' actions

Airlines seek to achieve some or all of these three goals through the formation of alliances, increasing their competitive advantage; however, it is not always assured that the formation of the alliance will yield such benefits. If the alliance is successful, the partner airlines will have achieved, indeed, a significant source of competitive advantage. If it is a failure, they will have increased their costs and wasted energy and time. Figure 4.1 replicates the framework given in Chapter 1, focusing here on the impacts that alliances can bring to the participating airlines.

The importance given to each of the three possible goals depends on the nature of the alliance and the characteristics of the airlines in each case. In general, regional alliances are more focused on obtaining stable market positions, whereas global alliances are more focused on increasing total passenger volume and reducing costs. The next five points summarize the positive impacts of alliances for the participating airlines.

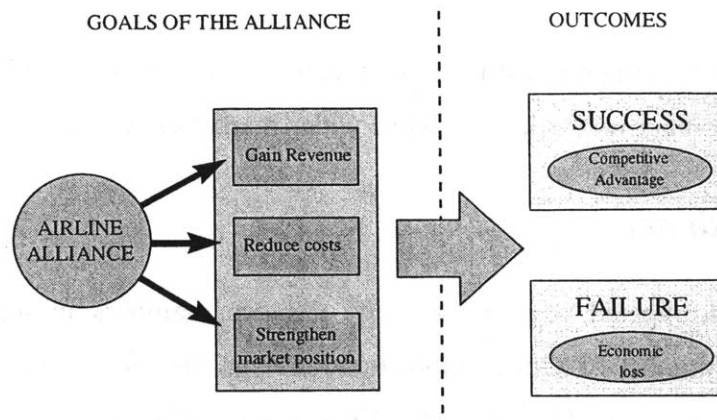

Figure 4.1. The impacts of alliances for the participating airlines

2.2.1.1. Increased Network Coverage

The effect of alliances on the size of the partners' networks is probably the principal impact of alliances. The participating airlines, through intensive use of codesharing, are able to expand the destinations they offer to customers, while at the same time incurring almost no additional operating costs. The advantages they obtain through this wider network coverage are obvious:

- They make their networks much more attractive for their customers through offering more destinations and flights (codeshare flights).
- They extend the coverage of their frequent flyer programs, which leverages significantly their marketing capabilities.
- They gain additional traffic by capturing passengers that, otherwise, would have flown with competing carriers offering online service (see 2.2.1.2).
- They gain cost advantages derived from wide network coverage and economies of scope, which in turn improve their productivity (see 2.2.1.3).

“Through alliances, the partners can get access to attractive airports and provide services to relatively thin markets where it would be unprofitable to operate services independently” (Oum and Park, 1997). Strategic alliances meant to link complementary networks, such as global and regional strategic alliances, produce a vast increase of markets being covered by the airline after the alliance is formed. The illustrative figures

presented in Chapter 1 (Figures 1.4 to 1.6) indicate the way in which alliance partners link their complementary networks to achieve wider market coverage.

Empirical Evidence

One of the most trumpeted improvements by alliance members in support of their partnerships is the number of additional destinations that they serve under the alliance. The *Star Alliance*, for example, in October 1998 was proud to announce its service to 654 different destinations through the operation of 1,446 aircraft, constituting by far the biggest airline alliance operating at the time. Figures 2.3 and 2.4 show the change in the number of destinations offered by Northwest to Europe and the Middle East after the alliance with KLM was formed. The alliance used the hub-to-hub link illustrated in Figure 2.2 to channel the new traffic to the new online destinations located beyond Amsterdam.

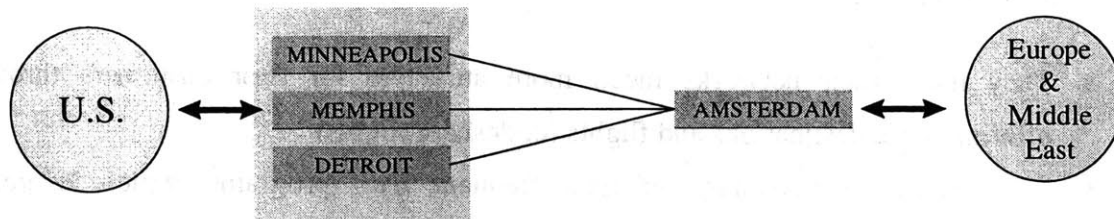

Figure 2.2. Northwest/KLM alliance's hub-to-hub link between the US and Europe and the Middle East

Examples like the ones presented in the above paragraphs are frequently cited in airline publications. Airline officials commonly refer to the significant increase in the number of destinations being offered after the alliance formation, which helps the airline to become part of a global network with extensive coverage.

2.2.1.2. Increase of Traffic Volume

A direct consequence of both the increase of network coverage and the strengthening of market positions on certain routes due to the formation of the alliance is an increase of traffic. This increment of traffic is critical for the alliance partners, representing the main source of incremental profits brought by the alliance. Alliances use different mechanisms to capture additional traffic. The figure presented below provides a framework to understand the main mechanisms used by alliances to gain higher levels of traffic under a hub-to-hub scheme.

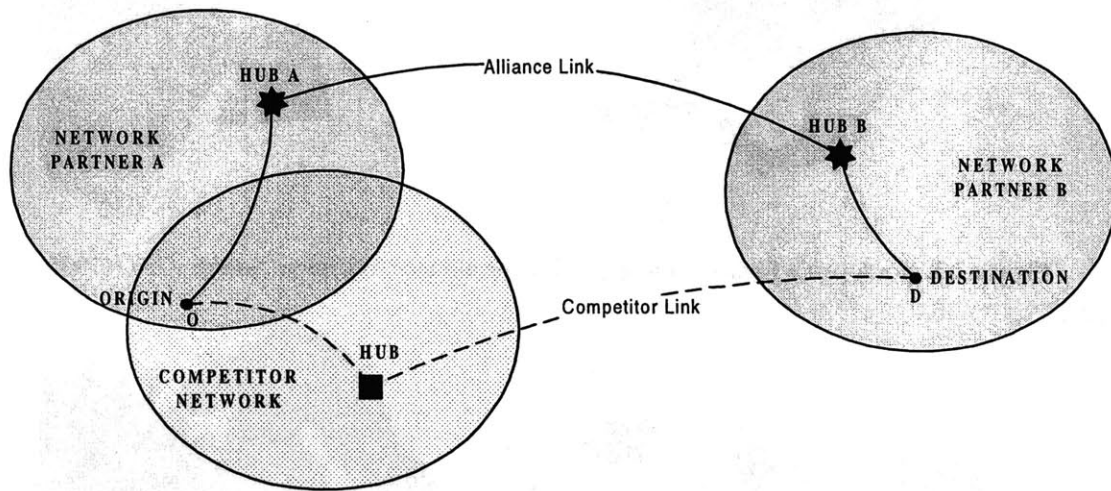

Figure 2.5. Alliances' mechanisms to capture additional traffic

By linking the partners' networks through hub-to-hub links, alliances use each partner's network to feed traffic to the other partner's network. By practicing parallel codesharing and adding capacity to the connecting link between hubs, the alliance increases its frequency and availability in the hub-to-hub city-pair, reinforcing its market position and gaining higher levels of traffic. However, for non-hub markets, such as that labeled O-D in the above figure, the alliance depends on other level of service variables in order to gain traffic.

On the one hand, the alliance counts on online connections, which are more attractive to customers than interline connections. The coordination of schedules to make more

convenient connections, the offering of broad frequent flyer programs, and the offering of shared airport lounges can make the alliance connection more attractive for the customer as well. However, because the alliance itinerary requires two connecting stops against one connecting stop of competing itineraries, the alliance must reduce fares in most cases to truly make more attractive its itinerary for the customer.

Consider the situation presented in the figure. In the market O-D, a passenger desiring to travel has two options: Fly with the alliance, making a three-leg trip connecting at the two alliance hubs, or fly with the competitor carrier, making a two-leg trip and connecting at just one hub. Clearly, the competing itinerary should be more attractive for the passenger in terms of travel time and connecting convenience. Therefore, in order for the alliance to capture such passenger, it must increase its level of service (LOS) in that market and offset the natural time advantage of the competing itinerary. The alliance can increase its LOS in two different ways.

First and more targeted to the business segment, the alliance can offer to its customers a more extensive frequent flyer program. "For a variety of reasons, most travelers prefer to fly with an airline serving a large number of cities" (Oum and Park 1997). In addition, because the alliance hub-hub-link frequently offers several flights a day, the frequency, and consequently the travelling flexibility, might be higher through the alliance itinerary. Although frequency is not as critical for long-haul international markets, it could make a difference for a small portion of the business travelers.

Second, the alliance can open low-fare classes, making its itinerary more attractive for leisure passengers willing to pay only low fares. The competitive itinerary could also counter with low fares, since airlines usually match fares. However, with the use of modern yield management systems, it would be expected to have a restricted number of such low-fare seats, given limited capacity on its flights. Therefore, by adding capacity to the hub-to-hub link the alliance increases the availability of low-fare classes for distant O&D markets. Additionally, it increases its dominance in the hub-to-hub city pair. Both effects result in an increase of traffic.

The alliance can further improve the LOS offered through the hub-to-hub link by adjusting the flight schedules in order to reduce connecting inconvenience. Chapter 4 is dedicated to the management of such alliance connectivity as a way to increase LOS and, consequently, gain higher levels of traffic.

Finally, the alliance can promote the increase of traffic on its itineraries through the multiple listing of its codeshare flights in CRSs screens. This codesharing effect is further discussed in Section 2.3.2, as a negative impact.

Empirical Evidence

Figure 2.6 shows the increase in traffic carried by carriers forming a regional alliance before and after a codesharing agreement took place. Passengers were taking exactly the same aircraft before and after the alliance formation; however, there is a significant increase in the alliance traffic following the formation of the codesharing agreement, which highlights the alliance ability to gain higher levels of traffic.

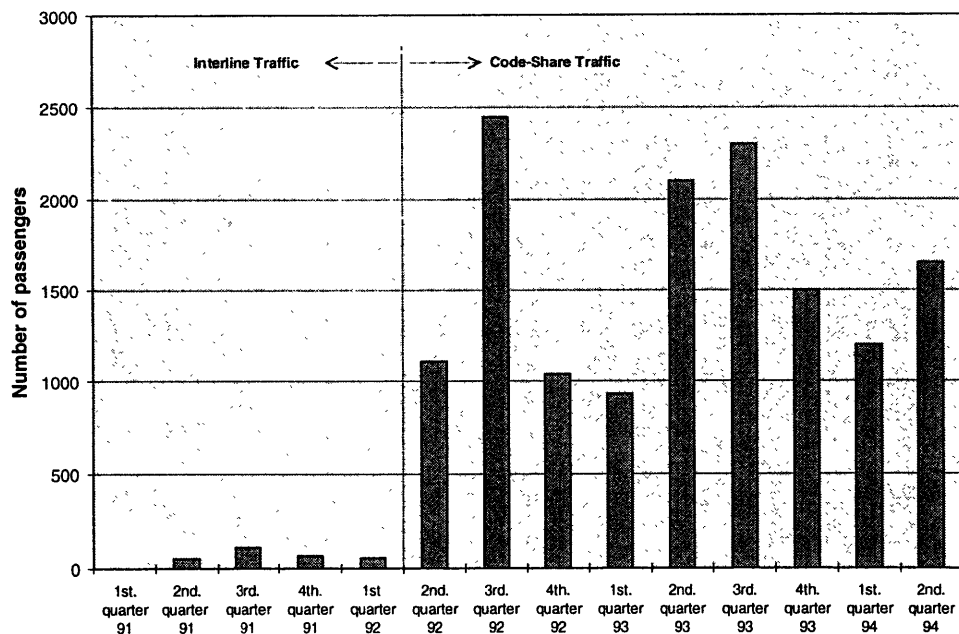

Figure 2.6. Number of passengers traveling on connecting United/British Midland flights between the US and Glasgow before and after the code-share agreement. Source: GAO (1995)

For global alliances, Table 2.1 shows the continuous increase of traffic and market share experienced by the Northwest/KLM alliance in several markets between the US and Europe and the Middle East, once the agreement took place.

Table 2.1. Number of Northwest/KLM passengers traveling between 34 US and 30 European and Middle Eastern cities, and alliance's market share. Source: GAO (1995)

| | 1991 | 1992 | 1993 | 6/93 to 6/94 |
|------------------|-----------|-----------|-----------|--------------|
| Northwest/KLM | 17,150 | 23,260 | 52,510 | 60,630 |
| All carriers | 1,488,160 | 1,688,570 | 1,744,090 | 1,810,780 |
| Market share (%) | 1.2 | 1.4 | 3.0 | 3.3 |

Figure 2.7 further highlights the increase in traffic experienced by the KLM/Northwest alliance. The plot shows a continuous increase in annual traffic carried through the hub-to-hub links, whereas it shows a more stable pattern in the traffic carried by other transatlantic flights of Northwest and KLM. It is interesting to note the positive impact of the antitrust immunity granted by the US government to the alliance in 1992.

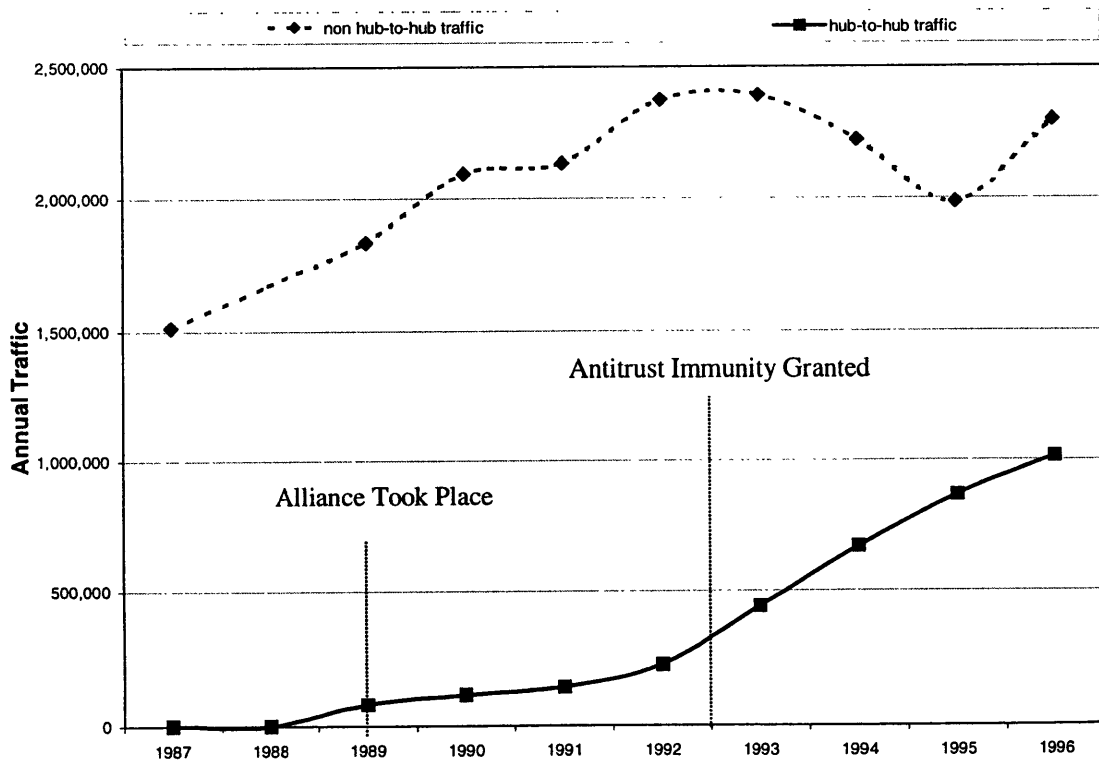

Figure 2.7. Evolution of the Northwest/KLM transatlantic traffic. Source: ICAO Statistics

The study of Clougherty (1998) suggests that alliances that enjoy a high network concentration in their domestic markets tend to have a competitive advantage to gain traffic for their international routes. Brueckner and Whalen (1998) found that international alliances offered higher average fares in gateway-to-gateway markets than they did in behind-the-gateway markets. Their findings represent a clear evidence of the alliance mechanism used to capture traffic discussed earlier. For markets distant from the hub-to-hub link, in which travelling with the alliance may not be especially attractive, the alliance uses the opening of low-fare classes to capture the segment of demand with low willingness to pay. In hub-to-hub markets, however, the alliance can restrict the number of low fare classes and still make their higher fare classes attractive due to its higher LOS.

2.2.1.3. Reduction in Costs

Alliances allow airlines to achieve cost advantages that derive from economies of density, economies of scale, economies of scope, and the sharing of common activities. Figure 2.8 illustrates the different cost advantages that an alliance can provide to its airline members, improving their operating costs.

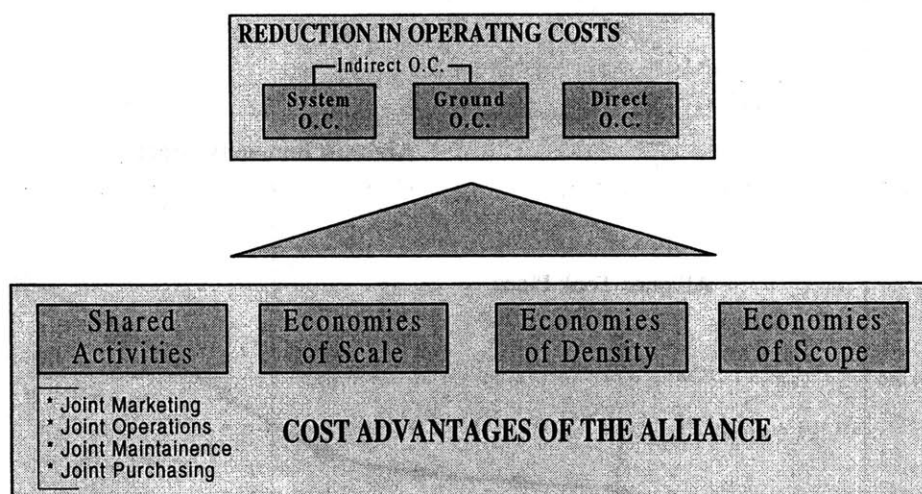

Figure 2.8. Effect of alliances on the cost structure of the airline members

Economies of traffic density occur when it is less expensive for an existing carrier to increase service than it would be for some other carrier to provide additional service on the same routes (Caves et al., 1984). Economies of density derived from airline alliances are primarily based on what is called *economies of link density* (Youssef, 1992), which refer to the increase of traffic volume on specific segments of the network. Higher volumes of traffic allow the use of larger aircraft, which result in lower unit costs. In addition, unit operating costs can be reduced as well by spreading out the total indirect operating costs allocated to the segment over a larger number of passengers. Because most strategic alliances are based on the hub-to-hub linkage scheme, economies of link density are an important element achieved through the formation of airline alliances.

Economies of Scope occur when “an existing airline, by expanding its route network, can serve new markets at a lower cost than a new airline can serve them.”¹ Economies of scope are particularly important under the hub-and-spoke network structure. Under such structure, the introduction to the system of one hub-to-spoke flight increases significantly the number of total O&D markets served by the airline. In fact, economies of scope yield economies of density in a hub-and-spoke network, since the level of traffic on one flight increases as the number of potential O&D markets served by the flight becomes larger. In addition, the consolidation of traffic into high-density flights carried out in large-scope networks (such as in the case of a hub-to-hub network scheme) reduces the impact of the stochastic variability of demand. This, combined with the application of yield management systems, provides higher load factors on the high-density flights, increasing the operational efficiency of the airline.

Economies of scale refer to the reduction in unit cost that an airline achieves by increasing its total output, while holding density constant (Youssef, 1992). Several research studies have found no empirical evidence of a decrease in airline unit costs when output levels were increased (see White, 1979). However, in the same way that airlines combined efforts to spread among themselves the costs of establishing complex

¹ Weisman, E. (1990): *Trade in Services and Imperfect Competition*, Dordrecht, The Netherlands. (Cited in the report by GRA , 1994)

and expensive computer reservation systems in the 1970s—achieving lower unit costs, alliances can also provide reductions in costs from economies of scale through the sharing of systems or advertising campaigns, for example. Joint purchasing and joint investments in maintenance facilities are additional practices that allow alliance partners to achieve economies of scale.

One of the most trumpeted sources of reduction in costs brought by alliances is the **sharing of common activities**. Probably due to the fact such reductions are easy to measure and are truly specific to airline alliances, the costs benefits from the sharing of common activities are often cited in speeches and articles about airline alliances. There are many different alternatives to reduce costs through the sharing of facilities and activities. Below are presented, in the author's opinion, the most significant activities being shared within airline alliances.

One of the most frequently carried out coordinated activities within alliances is the **joint operation of flights**, which has been called **codesharing**. Through the practice of codesharing, airline members can maintain service in low-profit routes, while withdrawing the aircraft previously used for those routes and allocating them to more profitable routes. In other words, codesharing helps airlines to rationalize their fleets and, consequently, improve their productivity.

The combined operation of flights or codesharing is a critical element within alliances; however, the sharing of other operating activities can have a significant impact on costs as well. For example, the coordination of **ground operations** for handling of aircraft, or the **check-in** of passengers at the gate can yield significant cost reductions.

Joint maintenance is a coordinated activity within alliances that has been carried out for a long time. The advantages from sharing maintenance operations are especially significant in the case of “D-check” revisions, where the aircraft is completely overhauled every fixed number of flight-hours. Frequently, airlines have become involved in arrangements where each carrier takes care of the “D-checks” for all the partners' aircraft of a given type, distributing the maintenance of each aircraft type

among alliance members. In addition, through maintenance agreements with foreign carriers, airlines do not need to establish maintenance stations in far-away destinations.

Joint marketing is another coordinated activity practiced within alliances that reduces the expenses of partners. Alliance members carry out combined marketing campaigns, where they advertise the brand of the alliance as comprising a seamless service in the entire combined network. In addition, alliance partners frequently get involved in arrangements for the sharing of CRSs and ticketing offices, which splits their costs among the alliance members. Alliances are also able to provide customers with services such as airport lounges and interactive, real-time flight information that add incremental value for the passengers at no incremental cost.

Finally, **joint purchasing** is increasingly being a common practice that takes place within airline alliances. By consolidating their buying power and forging long-term relationships with suppliers, alliance partners can drastically reduce the costs of purchasing products, ranging from passenger service goods to spare parts. However, this practice is still in its infancy and it will be years before it can be applied to large capital investments, such as the acquisition of aircraft. Joint purchasing adds an additional implication for the partner airlines: In order to carry it out, the partners have to homogenize their products, services and working practices. This task is arduous to accomplish and makes joint purchasing difficult to go beyond “peanuts and napkins”.

Empirical Evidence

Figure 2.9 shows the effect of the economies of scope achieved by the alliance hub-to-hub link of the Northwest/KLM partnership. The chart illustrates a clear increase in the average load factor of the alliance hub-to-hub flights with respect to the rest of NW or KLM transatlantic flights. As discussed above, this higher load factor can be explained by the larger number of O&D markets covered by the alliance hub-to-hub link, which diminishes the negative impact of demand variability. In turn, a higher load factor provides a higher return for the utilization of the aircraft and diminishes the costs per RPM of the alliance.

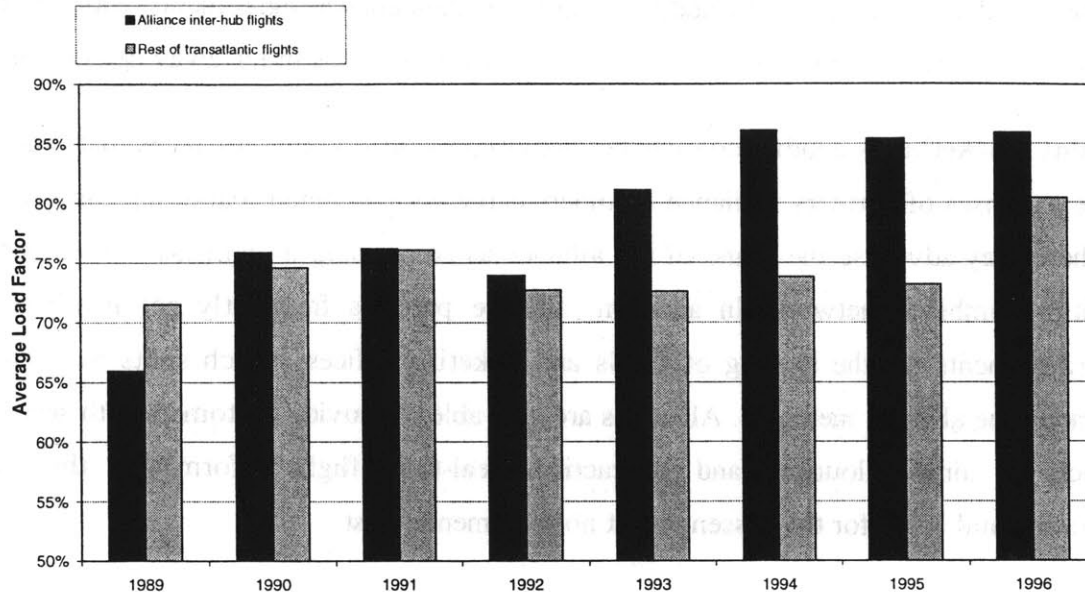

Figure 2.9. Evolution of NW/KL load factors in their transatlantic flights. Source: ICAO Statistics

The use of joint ticketing offices has been increasing considerably, and is expected to expand in the future. Northwest has joint ticketing offices with KLM, and the alliance plans to further expand those facilities. American Airlines shares many ticketing offices with Canadian Airlines International. The sharing of ticketing offices has traditionally been more frequent in airports and inter-modal connection centers. However, a more recent impact of alliances has been the sharing of city ticketing offices, a trend that is expected to expand in the future (Smith, 1997).

The study carried out by Park (1997) indicated the joint purchasing of fuel as one of shared activities found within the airline alliances analyzed in his study. A prominent example of joint purchasing within the context of airline alliances is DDS World Sourcing AG. DDS, created in 1995 by members of the Global Excellence Alliance (at that time Delta Airlines, Swissair, and Singapore Airlines), had the function of specifically locating products and services that could reduce costs to the three member airlines (Phillips, 1997). DDS efforts were focused mainly on joint purchase of cabin service items such as blankets, plates, cups, utensils and food catering services. Different regional offices had become expert in procuring certain products for the alliance. Savings in maintenance operations were achieved by striking pacts with

suppliers for spare parts and expendables that were common to aircraft types flown by the alliance. In words of a company official, 80% of the expendable parts were common to all three carriers. In the same direction, the Star Alliance in 1997 had 23 working groups engaged in a wide variety of issues directly related to the saving of costs throughout the alliance. Two of them were in charge of the specification of standardized products common to all alliance members, such as fuel, food, catering, cabin service items, flight entertainment and telephone systems.

Current sourcing efforts remain limited to relatively small products centered on customer service, but alliances are discussing plans to take the concept to a higher level. An example is the purchase of jet fuel, which represents a main part of the operating costs of an airline. According to airline officials, the many advantages of single-sourcing, coupled with the creation of innovative pacts between alliances and suppliers, has the potential to slash future operating costs by billions of dollars (Phillips, 1997).

2.2.1.4. Access to Congested Airports and Regulated Foreign Markets

Many airports suffer from increasing congestion. Airlines wanting to enter new markets through those airports are limited by the scarcity of slots and gates. Because typically there is one carrier that dominates each airport, forming an alliance with such a carrier represents an alternative to waiting for slot availability. It is a fast way to obtain a good marketing positioning in the corresponding airport.

In addition, even without any capacity constraint, new entrants may encounter difficulties in reaching potential customers. By entering into an agreement with a local airline that knows the market well and knows how to deal with local customers and suppliers, the new entrant can achieve an easy penetration in the market. Furthermore, in international aviation, regulation concerning air traffic between foreign countries can hinder one airline's penetration of new markets. Entering into alliances with foreign

airlines, many of them government-owned, represents in many cases the only viable alternative to access foreign destinations.

Empirical Evidence

Figure 2.10 illustrates the concentration of slots faced by major European airports in 1995. An airline wishing to enter new markets with Rome as a destination, one of many European congested airports, would find it difficult to obtain attractive slots. However, by entering into a partnership with Alitalia, which owns most of the slots at the airport, it can use flight and schedule coordination to make its flights more attractive.

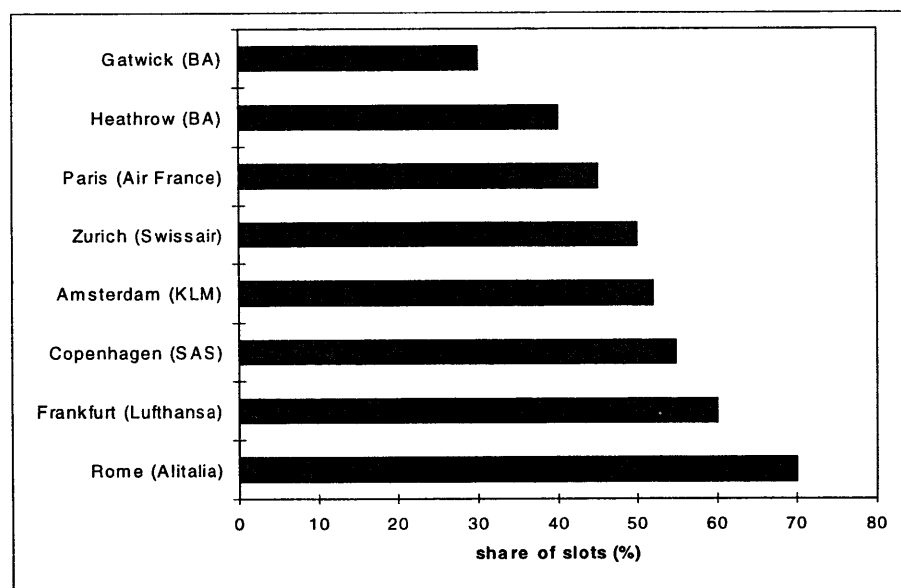

Figure 2.10. Airlines with biggest share of take-off and landing slots at European airports in 1995. Source: The Economist, 1997

The fact that many alliances require the establishment of open skies agreements between the two countries involved in the partnership to obtain government approval is a clear evidence of the use of alliances to penetrate foreign countries. For example, the antitrust immunity granted to the alliances between KLM/NW and UA/LH happened just after the United States had reached open skies agreements with The Netherlands and Germany, respectively.

2.2.1.5. Avoid Competition with Airline Partners and Reinforce Dominance

The partnership with a former competitor eliminates the disadvantages of being constantly in a fight for the market against the partner. In some city-pairs, partners move from a situation in which two carriers compete for the market to a completely different situation in which a single carrier dominates its local market and has the potential to exercise market power. This represents an advantage for the allied airlines, but obviously not for the rest of the industry. Hence, this issue regarding competition is further discussed in Section 2.3.2, as a negative impact of alliances.

Empirical Evidence

The alliance between British Airways and American Airlines is a clear example where the formation of the alliance has reduced significantly the level of competition on certain routes. In a letter presented by top executives from Continental Airlines, Delta Air Lines, Tower Air, Trans World Airlines, United Airlines and US Airways to the US Secretary of Transportation in September of 1998, they address the competition issues in the US-UK market brought by the proposed AA/BA alliance.

They highlighted the US-UK market as being the largest intercontinental aviation market of the world, accounting for 37% of all traffic between the US and Europe. With the formation of the alliance, AA/BA would have a monopoly on 18 US-UK city airports, controlling approximately 67% of the seats between the United States and Heathrow, 60% of the seats between the United States and London, and 57% of the seats between the United States and the UK.

2.2.2. Negative Impacts

The effects of alliances are not always beneficial for the participating airlines. While alliances have the potential to reduce some of the costs faced by airlines, they can also imply additional costs. Thus, alliances force participating airlines to make a significant

effort in order to support their formation. These costs are mainly **transactional costs**, associated with the interaction between the cooperating carriers (Youssef, 1992). They range from pure financial costs to culture-related costs.

One common alliance effect that increases the costs of the participating airlines is the standardization of activities among alliance members. Partners must bear the expenses of updating their system and service procedures in order to meet the common alliance standards. In addition, during the life of the alliance, the partner airlines must face the costs of monitoring alliance arrangements in areas such as standardization of passenger service, capacity management, schedule coordination, and revenue distribution among others. These costs might be small taken individually; however, at an aggregate level they can be significant.

More importantly, partners require a significant management effort in order to embed the new inter-airline culture brought by the alliance within the organization. This effort might be difficult to quantify in dollars, but can represent a significant physiological hurdle for the people inside the organization. Employees must be trained, educated in a new business environment where traditional flag-carrier single-airline archetypes must evolve into new global-network multi-airline partnership paradigms in which carriers must cooperate together under one same alliance brand. If the alliance fails to accomplish its goals and is ended, the employee morale can be significantly damaged. Skepticism might arise, which will in turn hinder the motivation of employees in support of further alliances in the future.

It is under this perspective where the **opportunity costs** derived from the formation of alliances fit in. Because the formation of the alliance engages an airline with one particular carrier, the airline misses the opportunity of gaining additional benefits from the formation of alliances with other carriers. Although most airlines today form alliances with different carriers simultaneously, truly strategic alliances impose certain limitations and control on the current alliance members and the carriers desiring to become new members, regarding the additional alliances they might be engaged in. In fact, one of the causes of the difficulty experienced by airline management in selecting

the right alliance partner is this opportunity cost, since it is extremely difficult to quantify.

The opportunity cost of alliances can be viewed under two dimensions: Time and scope. The *time* dimension is related to the risk of failing to make the alliance successful and limiting, consequently, the airline's ability to become engaged with other carriers in the future. The *scope* dimension, however, is related to the airline's inability to form alliances with a large number of carriers simultaneously.

Another alliance factor that must be considered in the evaluation of the alliance costs is the nature of the transactions amongst alliance members. Youssef (1992), referring to airline alliance transactions as externalized transactions, studied previous research in this area.² In his dissertation, he highlights two main shortcomings of the externalized transactions: (1) *bounded rationality*, defined as the "inability of the human minds to process all the information necessary in order to predict all possible sources of conflicts and incorporate them in the contracts related to the transaction;" (2) and, *opportunism*, defined as "self-interest seeking by individual transactors." These two shortcomings contribute to the overall costs implied by the formation of alliances.

In consequence, alliances might just not provide the expected results. There are many examples of alliances that have ended up being more costly than productive. Table 1.2, in Chapter 1, illustrates the average survival rate of airline alliances. The figures shown in the table suggest that many of the alliances terminate before the contract termination date.

In general, airline alliances are less likely to be successful in the case of point-specific alliances. For example, American Airlines entered into an agreement with Cathay Pacific to code-share flights between Los Angeles and Hong Kong that was terminated just after its formation (GAO, 1995).

² Williamson, O.: "The Vertical Integration of Production: Market Failure Considerations," *American Economic Review*, May 1971, pp. 112-123, and *Markets and Hierarchies*, the Free Press, New York, 1975.

2.3. Impacts on the Rest of the Industry and Stakeholders

2.3.1. Positive Impacts

2.3.1.1. Increased Accessibility for Passengers

Through alliances, passengers have more choices for travelling in affected O&D markets. Alliances offer them the possibility of reaching destinations through additional routes with on-line connections. Such positive impact of alliances becomes more significant for those destinations that before the alliance formation were just accessible through interline connections.

Wider network coverage represents an important advantage for passengers, and to some extent, can produce a stimulation of demand that will result in additional traffic for the airline. The increase in passenger choice is true not only at the itinerary level, but also at the fare level. Some itineraries, the ones that are preferred by the customer, might have the fare-class desired by the customer already sold out; however, the alliance might offer alternative itineraries for which the desired fare-class is still available.

2.3.1.2. Improvement of Passenger Service

“A properly executed alliance will surely improve service quality by increasing flight frequencies available to customers, by offering more convenient flight schedules, and by increasing the proportion of on-line connections” (Oum and Park, 1997). Although codesharing alliances produce an increase in just “apparent” frequency (since the number of flights operated by the alliance as a whole remains constant—see multiple listing on CRSs in 2.3.2.2), loyal customers to one carrier might benefit from such increase. Through alliances, passengers can reach long-haul destinations by flying all the way under the same airline code (despite flights might be operated by different carriers). This on-line service translates into more convenient layover times in the

connecting airports, a greater confidence in the management of luggage, and a general impression that the trip is better coordinated.

One significant advantage of alliances for passengers is that they provide their customers with frequent flyer programs of world-wide coverage that enable passengers to get frequent flyer points by flying with any of the partner airlines. Being a frequent flyer member of any airline participating in the Star Alliance, for example, would mean that it is possible to obtain frequent flyer points for almost any route between important city-pairs in the world. Additionally, the sharing of airport facilities, such as lounges and ticketing offices, can make traveling more pleasant to the passengers that are flying far away from their homes, into foreign countries with unknown cultures and customs.

2.3.1.3. Potential Reduction of Fares

Since airline alliances can reduce unit costs, there exists the possibility of reducing fares or increasing the quality of service. This potential reduction of fares is more theoretical than realistic, as there is almost no empirical evidence of it. Nevertheless it can always be argued as a positive impact of airline alliances.

2.3.1.4. Reduction of Air Traffic Congestion.

Some code-sharing agreements are implemented in order to reduce the number of aircraft operated on routes not likely to be profitable as a way to rationalize service. In these situations, there is a consequent decrease of air traffic congestion that can be beneficial for the general industry. However, most code-sharing agreements are intended to increase service without reducing the number of aircraft being operated, and therefore, it is not likely to have a reduction in congestion from these agreements.

2.3.2. Negative Impacts

Airline alliances may produce many advantages to customers and to the industry in general, but there exist a large number of negative facets of alliances that could damage

the competitive equilibrium of air transportation markets as well. The primary negative consequence is the possibility of exercising market power by the airline partners on certain routes.

2.3.2.1. Exercise of Market Power

Airline alliances may increase its members' ability to exercise market power on certain routes where the level of competition is small. The main negative impacts of airlines exercising market power are that

- They can constrain service and raise prices without fear of competitive responses, and
- They can prevent other potential carriers from competing on the routes where they exercise market power.

In a report prepared by the Industry Commission of Australia (ICA, 1997), three major factors are identified as affecting the possibility for an alliance to exercise market power on any given route: The existence of barriers to entry, the nature of competition, and the characteristics of the alliance.

Barriers to entry are, for example, bilateral agreements between governments of foreign countries that limit the number of each nation's operators on a route, or the scarcity of slots at any of the origin-destination airports. The first barrier explains why the US government has required signing "open skies" agreements with foreign countries in order to grant antitrust immunity to alliances between American carriers and foreign carriers (usually the country's flag carrier). In the second case, the ownership by an alliance of large portion of the slots in a major and congested airport puts the alliance in a position of exercising market power by controlling the access to the airport.

Regarding **the nature of competition**, there might be routes where competition is lower or higher depending on specific reasons, such as historical trends or events. "When competition is effective, any attempt by an airline to restrict the number of air

services or to raise prices will simply result in a loss of market share to other competitors” (ICA, 1997). However, if competition is not effective, there will be a risk that the alliance exercises market power. “This is likely to happen in cases where the alliance partners together account for a significant share of the passengers on a route or when there is little or no competition from other airlines on indirect or substitute routes” (ICA, 1997).

Finally, **the features of the alliance** are strong determinants in the possibility of exercising market power. Alliances that incorporate practices such as codesharing, joint pricing, revenue pooling, etc., have a much higher possibility of exercising market power than the alliances that just incorporate the traditional interline agreements such as the coordination of baggage, check-in, etc. According to GAO (1998a), “alliance sales and marketing practices—which include frequent flyer programs, travel commission overrides, multiple listing on computer reservation systems, and corporate incentive programs—may also reduce competition.”

These are the three main factors that governments and regulators should take into account in order to determine if an alliance can endanger the competitive equilibrium on a particular route. The alliance between British Airways and American Airlines is a clear example of a case in which the three factors indicate the possibility that the alliance exercises market power in the transatlantic link between the UK and the US. It is important to make clear that the above factors represent elements that facilitate the exercise of market power by alliances, but are not sufficient conditions. In fact, while it is clear that alliances favor the consolidation of industry players into large alliance groups, it is not clear that they produce lower competition or an increase of passenger fares. Airlines claim that the consolidation of carriers within alliances does not necessarily imply a reduction of competition, decrease of service, or rise of fares. In Section 2.3.2.5 this issue is further discussed.

2.3.2.2. Multiple listing on CRS Displays

One clear disadvantage for alliance competitors regarding the use of codesharing is that the same combination of flights can appear more than three times in the computer reservation system (CRS). The replication of the CRS screen for a Chicago-Berlin request of Figure 2.11 was included in the report of the US General Accounting Office in 1995. The figure illustrates that the codesharing practice between United and Lufthansa allows three flight combinations to appear in the first screen. Once, with the two flights using the code of United, another time with the codes of Lufthansa, and finally with the code of the real operator in each case. The negative impact of this fact on competition is that alliance airlines can be listed several times on the first screen, pushing down to the second screen potential competitors, such as the interline connection between American Airlines and Lufthansa given in the figure.

The European Union has already established limitations on the multiple listing of codesharing flights, but in the US the regulation is not clear yet. Since between 70% and 90% of computer reservation system bookings appear to be made from the first screen (Oster and Pickrell, 1988), the alliance partners that use codesharing have a marketing advantage over competitors, while passengers have access to fewer “real” combinations of flights.

2.3.2.3. Passenger Confusion and Inconvenience

Another negative aspect of alliances is the confusion that they may cause to passengers when they realize without notice that they are flying on a codeshare connection³. This is particularly true at airport luggage claims in the deplanement process. Passengers may experience frustration when they receive onboard service from another carrier that was not expected or that is regarded as less valuable for them. To prevent this, carriers forming alliances are trying to standardize the services offered onboard in an attempt to diminish this negative effect.

³ Even though in several countries is required that the travel agent itinerary indicates the true operator of a codeshare flight, many passengers do not pay attention to it.

CRS Screen-Worldspan:

(Screen One)

| | Airline | Number | Origin | Destination | Leaving | Arriving |
|---|---------|--------|-----------------|-------------|---------|----------|
| 1 | LH | 2423 | TXL | FRA | 1125A | 1235P |
| 2 | LH* | 6430 | FRA | ORD | 130P | 420P |
| | LH* | 6430 | UNITED AIRLINES | | | |
| 3 | UA* | 3647 | TXL | FRA | 1125A | 1235P |
| 4 | UA | 941 | FRA | ORD | 130P | 420P |
| | UA* | 3647 | DLH LUFTHANSA | | | |
| 5 | DI | 7045 | TXL | DUS | 1135A | 1240P |
| 6 | AA | 157 | DUS | ORD | 130P | 405P |
| 7 | LH | 2423 | TXL | FRA | 1125A | 135P |
| 8 | UA | 941 | FRA | ORD | 130P | 420P |

Actual operator of LH6430

Actual operator of UA3647

(Screen Two)

| | Airline | Number | Origin | Destination | Leaving | Arriving |
|---|---------|--------|-----------------|-------------|---------|----------|
| 1 | LH | 2628 | TXL | DUS | 1115A | 1220P |
| 2 | AA | 157 | DUS | ORD | 130P | 405P |
| 3 | UA* | 3645 | TXL | FRA | 1025A | 1130A |
| 4 | UA | 941 | FRA | ORD | 130P | 420P |
| | UA* | 3645 | DLH LUFTHANSA | | | |
| 5 | LH | 2419 | TXL | FRA | 1025A | 1130A |
| 6 | LH* | 6430 | FRA | ORD | 130P | 420P |
| | LH* | 6430 | UNITED AIRLINES | | | |
| 7 | KL | 144 | TXL | AMS | 1150A | 110P |
| 8 | KL | 615 | AMS | DTW | 240P | 515P |
| 9 | KL* | 8175 | DTW | ORD | 655P | 717P |
| | KL* | 8175 | NORTHWEST AIR | | | |

Figure 2.11. Multiple listing on CRS displays. Source: GAO, 1995

2.3.2.4. Concentration of Traffic on Alliance's Hubs

Concerning airport congestion, alliances can have a negative impact if the hubs of the alliance partners suffer congestion. The increment of traffic due to the alliance and the consolidation of traffic through the hub-to-hub link increase congestion at the alliance hubs and has a negative effect on the quality of service offered by air Traffic Control and the airport authorities. These negative effects are over the airline members of the alliance, the passengers, and the rest of the airlines.

2.3.2.5. Impact on Fares. Recent Studies

Both regulators and academia have given significant attention to the impact of airline alliances on passenger fares. However, there is little conclusive evidence of these impacts. The GAO (1995) study examined the effect of alliances between the US and foreign airlines. It argued that “insufficient data exists to determine the effect of alliances on fares”. The report goes further to conclude that the absence of “complete and accurate data” prevents adequate monitoring of the competitive impact of alliances.

Although there is a general concern about the alliances’ potential to exercise market power and rise fares, most recent studies carried out to determine the effects of airline alliances over air service fares seem to indicate that consumers are generally better off due to alliances. Oum et al. (1996) measured the impact of complementary codesharing agreements between non-market leaders on the market leader’s price and passenger volume. They estimated an econometric model on panel data for 57 transpacific routes over the period 1982-92. Their findings indicated that the codeshared service offered by two non-leader carriers makes the market leader behave more competitively, lowering the equilibrium price of service supplied by it. This result suggests that, as expected, complementary codesharing is less likely to have a negative impact on competition.

The report of the Industry Commission of Australia (ICA) (1997) measured the effect of codesharing on airfares on international air routes to and from Australia, using a simple linear regression model. The results showed that the effect of codesharing had a positive and significant effect on economy fares (in the sense that they were lower when codesharing was present) and an insignificant relationship with discount fares.

Park (1997) estimated several econometric models using panel data for the transatlantic markets for the period 1990-1994. His finding indicated that equilibrium fares in the alliances observed serving those markets had been lowered by 19%-22%. Brueckner and Whalen (1998) used data from the third quarter of 1997, and accounted for all existing alliances. They found out that alliances lead to lower fares in behind-the-

gateway markets (18% lower than nonallied carriers), while they lead to higher fares in gateway-to-gateway markets.

The nature of the data used in the above analysis makes it difficult to generalize their findings, particularly for those studies that used published fares instead of the average values of the actual fares paid by passengers. The sources of data commonly used for such analysis are the ICAO, the IATA or the US DOT databases on air traffic. However, as pointed out by the GAO report (1995), none of those data sources presents a comprehensive record of the characteristics of the total traffic carried in most international O&D markets. In addition, some studies (such as the ICA report) use very aggregate data; data for all kind of markets and periods, airlines and routes, without keeping track of a particular route or airline.

Nevertheless, all studies all studies that were analyzed indicate that, overall, there is no significant increase in fares due to the formation of alliances. It is clear that the formation of alliances favors the consolidation of competition. However, even though airlines that achieve dominant market positions have the potential to drive out competitors with smaller shares and eventually raise fares (GAO, 1999), there is no clear evidence of such effect in a broad basis within the context of airline alliances so far. In fact, the results of the studies support the alliance framework presented in Section 2.2.1.2. Because alliances increase the accessibility to international O&D markets through their multi-hub networks, they increase as well the number of low-fare seats available to customers in every affected O&D market. Although alliances will restrict the seat allocation to low-fare classes in their hub-to-hub city-pairs (particularly in peak periods), other alliances connecting such markets through their additional hub-to-hub links will make the overall availability of low-fare classes increase.

This increase in the number of low-fare seats is especially beneficial for leisure travelers, since business travelers tend to accept higher fares in exchange for higher LOS. Consequently, alliances seem to provide lower fares to the leisure traveler, while they provide higher quality of service (at potentially higher fares) to the business traveler. Airline officials, airline experts, and academia have recognized that the

introduction of modern revenue management systems and hub-and-spoke network structures have lowered the average price paid for discount fares while it has increased the price paid for business full fares. The same can be said for airline alliances, which in turn, can be seen as an extrapolation of the hub-and-spoke network to a multi-hub network scheme operating inter-continently.

2.4. Conclusions

This chapter has presented a summary of the possible impacts of alliances on the airline industry and its stakeholders. The results of the literature review that has been carried out in the elaboration of this chapter have shown both *pros* and *cons* of airline alliances. Nonetheless, it is clear that alliances provide significant advantages to the participating airlines, representing important **strategic tools** to compete in the global skies. These advantages are the main reason why alliances have become increasingly important as globalization shapes the economy of the twenty-first century.

The advantages for the participating airlines with alliances are expansion of networks, gains in total traffic, cost savings, and the reinforcement of market positions on given routes. Unless alliances are not successful in achieving such goals and partners must bear the costs of their formation, all that alliances can provide to their member airlines are positive impacts. However, it is not easy to extract all the benefits out of the alliance, and there is an opportunity cost associated with them. Alliances will result in a failure if the expected coordination of activities is not carried out in a productive way and if cultural differences among partners raise significant tensions between organizations.

For passengers, airline alliances represent increases in the level of service. The benefits passengers can obtain from airline alliances include significant gains in accessibility to foreign markets, broader frequent flyer programs, increases of frequency on certain routes, the possibility of having access to passenger lounges in all connecting airports, etc. However, there are potential negative effects of airline alliances that can offset all

their benefits. These negative effects are mainly represented by the possibility of alliance members to exercise market power. In such situations they can constrain service and raise prices without fear of a competitive response, and they can prevent other new carriers from entering the markets where they exercise market power.

There is no conclusive empirical evidence with respect to the negative impacts of alliances, although many studies suggest their potential negative outcomes in the future. Regulators and governments have the final word in approving airline alliances and establishing conditions to maintain competition. There is a trade-off between providing national carriers with access to foreign markets through bilateral agreements and the granting of antitrust immunities to alliances, and the possibility of market power exercise by alliance partners on certain routes. In this trade-off, public authorities must look at three major factors affecting the ability of airlines to exercise market power: the existence of barriers to entry, the nature of competition and the features of the airline in each route.

The high network connectivity of alliance hub-to-hub structures provides increased accessibility to many international O&D markets. This increase in accessibility seems to be the main driver for the change in international fares experienced by the airline industry after alliances have become dominant players. The increase in accessibility, in turn, increases the number of discount fares offered to customers. However, the fare levels of alliance hub-to-hub city-pairs should be expected to increase, particularly for business travelers.

It is clear that alliances are beneficial for the airline industry. However, governments and regulators should continue to monitor the development of airline alliances to prevent the erosion of competition.

PART II

IMPACTS OF AIRLINE ALLIANCES ON AIRLINE MANAGEMENT: NETWORK CONNECTIVITY AND REVENUE MANAGEMENT

Chapter 3

Using Alliance Connectivity as a Strategy for Market Growth

3.1. Introduction

As was highlighted in Chapter 1, the fundamental premise behind airline alliances is to increase market coverage by linking the networks of the alliance members, so that service to multiple additional destinations is offered to customers. However, once the alliance is formed, there are important management decisions to be made so that alliance synergies are actually realized. In particular, management must decide how the airline members' networks will be operated under the new alliance scenario.

Within this decision-making process, the management of aircraft capacity and the coordination of flight schedules are critical elements affecting the increase of alliance network connectivity, and consequently, the gain of higher levels of traffic. This connectivity management requires what is known in the industry as coordination of flight scheduling. As was found by Park (1997), the coordination of flight scheduling is one of the most common activities carried out within airline alliances, particularly within strategic alliances (see Table 1.3). In this chapter, however, the key factors that allow such network connectivity to maximize the benefits of the alliance will be analyzed.

In Section 1.5, the main motivations for alliance formation in the airline industry were addressed. The primary conclusion was that the increase of service coverage to other markets where the alliance members did not offer service before and the strengthening of those markets that were already served are the two fundamental alliance advantages that explain why airlines have increasingly formed alliances in the last decades. The

combination of these two alliance effects produce as a consequence an increase of the alliance market share out of the total traffic between the regions where alliance members are based (see Figure 1.9 in Chapter 1). Therefore, one way to measure alliance success is to focus on the increase of market share in both the new markets served just after the alliance formation and the markets that were already served before the alliance formation. The main hypothesis of this study is that the level of network connectivity within the alliance is a key factor in the increase of market share, and consequently, alliance success.

The analysis presented in this chapter is based on the assumption that the stimulation of overall demand due to the alliance formation is small. Because of this assumption, and because the study focuses on market share instead of absolute traffic, evaluating the alliance increase in market share is equivalent to analyzing the ability of the alliance to capture traffic that otherwise would have traveled with competing carriers. Figure 3.1 illustrates the typical situation faced by a passenger desiring to travel in a market where an alliance is involved. The passenger desires to travel from A to B. Assume that, before the alliance was formed, the passenger had only one alternative to make such trip. This alternative was to fly with a competing carrier through its hub. However, once the alliance is formed, the passenger has the option to fly through the alliance link, making two connections, or to fly through the competitor link, making one connection. If the alliance is able to manage capacity in order to make competitive fares available in the market AB and if it carries out a convenient coordination of connecting flights, the passenger might shift his/her travelling patterns and fly with the alliance.

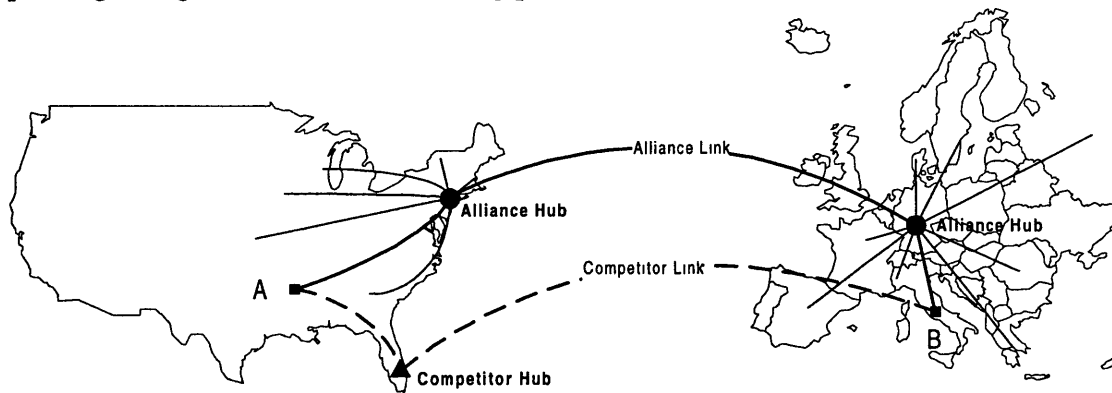

Figure 3.1. The alliance link versus competitor links

Of particular interest are the key factors that determine the ability of the alliance to capture passengers in markets like the one presented in the above example. Thus, the study focuses on markets connected through the hub-to-hub alliance scheme presented in the figure, and we will analyze the impact of network connectivity on the alliance's ability to capture traffic and gain market share.

First, in Section 3.2, the network model used in the analysis is presented. The focus of the thesis is on a hub-to-hub alliance scheme, where the networks of two alliance members are connected through inter-hub flights. The analysis is based on a real-world alliance example that follows such a scheme: the NW/KL alliance. Section 3.3 presents the data that has been used in the analysis, which is divided into two types: traffic data, and scheduling data. Section 3.4 presents the results obtained from a first evaluation of the data in terms of market share evolution. Here, an examination of the alliance market share evolution in the different O&D markets allows us to come up with some preliminary conclusions regarding the impact of the NW/KL alliance.

Section 3.5 introduces a measure of network connectivity within the hub-to-hub alliance scheme, which we have defined as **alliance accessibility**. In Section 3.6, the statistical results of the analysis on the relationship between market share growth and accessibility at an O&D market level, which is based on a linear regression model, are presented. Finally, a sensitivity analysis on the regression model is performed in order to estimate the way in which the management approach to alliance connectivity affects the alliance's gain of market share.

3.2. The Alliance Hub-to-Hub Model

The analysis carried out in this Chapter is based on the scheme of global strategic alliances presented in Section 1.3.1, where the networks of the two partners are complementary and linked through inter-hub flights (see Figure 1.4 in Chapter 1). Under this alliance structure, each member has an extensive domestic network strongly connected by a hub-and-spoke system. Out of each hub, several international flights

connect multiple domestic locations with different international destinations, and provide economies of density through the consolidation of traffic and the use of large aircraft. In many situations, the global strategic alliance is formed between airlines located on different continents. That is the case of the example presented in Figure 3.1, where the alliance hub-to-hub links are transatlantic flights.

A real-world example of the global strategic alliance model discussed above is the international alliance started in 1989 between Northwest and KLM. The NW/KLM alliance has been selected as the case study to be analyzed because it is such a good example of the hub-to-hub model and there is enough historical data. Figure 3.2 illustrates the linkage of the Northwest and KLM networks through their hub-to-hub flights. The American carrier has three hubs located in Detroit, Minneapolis, and Memphis, while the Dutch carrier has only one hub located in Amsterdam. The figure includes Boston as an additional Northwest hub because, in fact, it has acted as a hub during part of the period of study.

The alliance model discussed above just considers the connectivity between the two networks through the hub-to-hub flights. However, both Northwest and KLM have flights originating at their hubs and arriving at non-partner's hub destinations. Therefore, in order to perform the analysis on hub-to-hub connectivity, the alliance traffic traversing the hub-to-hub link had to be isolated from the rest of the NW/KL traffic in the two networks.

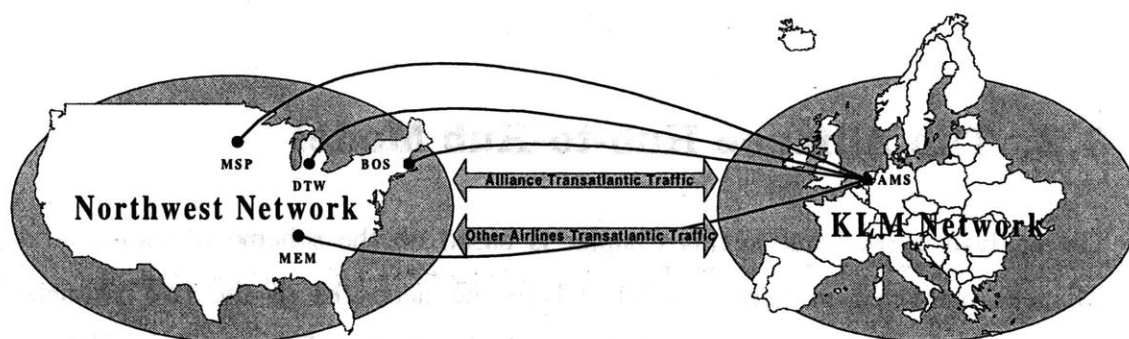

Figure 3.2. Northwest/KLM alliance network

3.3. The Data of the Analysis

The data required to do the alliance connectivity analysis can be divided into two types. The first type of data is *transatlantic traffic*. Since the analysis focus on the changes in market share experienced by the alliance, such traffic data must include passengers carried by both the alliance carriers and the competing carriers. The second type of data is *schedule data*. Flight schedules of Northwest's and KLM's flights connecting every origin with every destination considered in the analysis must be gathered in order to determine the levels of alliance connectivity.

The traffic data was obtained from the US Department of Transportation (DOT), which collects traffic data from a 10% sample of the passenger coupons collected by the US airlines (DOT's O&D Database). Such source of data provides traffic by complete itinerary (see its definition below) only for those passengers that flew at least one leg with a US carrier. Therefore, in order to gather complete information on international traffic by both US and foreign carriers on each O&D market, the analysis focuses on US airports to which no foreign carrier had scheduled regular transatlantic operations. Since British Airways' network covers a vast number US destinations, the number of options with a significant level of international traffic was limited. In this analysis, three US airports were considered: Nashville (BNA), Kansas City (MCI), and St. Louis (STL). For these three airports, complete information about the annual traffic originating at each airport and arriving at any destination in Europe, Asia, the Middle East, and North of Africa was gathered for the period 1990 to 1997.

Therefore, for each O&D considered in the analysis, for example Nashville-Berlin (BNA-TXL), we had the number of passengers carried by each carrier or combination of carriers through each itinerary every year from 1990 to 1997. Here, the word itinerary refers to the physical path actually followed by passengers. In the O&D market considered above, an alliance itinerary could be, for example, Nashville-Detroit-Amsterdam-Berlin on NW/KL flights, while a competing itinerary could be Nashville-Chicago-Frankfurt-Berlin on UA/LH flights.

Because the level of network connectivity is directional—that is, it can be different depending on the direction of the traffic, the analysis focused on outbound traffic and its connectivity (passengers leaving the US). The analysis throughout this chapter uses the variable market share to evaluate the success of the alliance. This measure of market share is used at two levels: the O&D level and the aggregate level. At the O&D level, the measure of alliance market share used in this chapter represents the total traffic carried by the alliance as a percentage of the total annual traffic on the O&D market considered. At the aggregate level, the total traffic originating at each of the three airports analyzed was considered, so that the alliance market share represents here the percentage of the total annual traffic originating at each of the airports (outbound traffic) carried by the alliance.

The schedule information on Northwest and KLM flights was collected from worldwide and US domestic editions of the *OAG Desktop Flight Guides* for the years 1990 to 1997. Although flight schedules change throughout the year, the June edition in each of the 8 years was selected as the data source for the analysis, since June is a representative peak (summer) schedule month.

3.4. Market Share Analysis

As was mentioned in the introduction, the main purpose of the analysis carried out in this chapter is to evaluate the success of the NW/KLM alliance in gaining market share, and to determine the impact of the alliance connectivity on such market share increase. For this purpose, the market share of the NW/KL alliance at the aggregate level—defined as the portion of the total transatlantic traffic originating at each of the three airports considered in the analysis that was carried by Northwest and/or KLM—has been calculated. The intention is to observe the evolution of the annual outbound transatlantic traffic that flew out of each of the three airports through the alliance hub-to-hub link, expressed as market share of the total annual traffic. Figures 3.3 to 3.5 show the results for each of the originating airports.

Table 3.1 below presents the actual traffic that flew from the three airports to destinations across the Atlantic. Note that, although the market share performance of the alliance hub-to-hub link is lower in St. Louis, the level of traffic carried by the alliance is higher than in the other two airports.

Table 3.1. Annual outbound transatlantic traffic out of the three airports (passengers)

| Year | Nashville (BNA) | | | Kansas (MCI) | | | St. Louis (STL) | | |
|------|-----------------|----------------|------------------|--------------|----------------|------------------|-----------------|----------------|------------------|
| | NW/KL H-H | NW/KL Total | Total Traffic | NW/KL H-H | NW/KL Total | Total Traffic | NW/KL H-H | NW/KL Total | Total Traffic |
| 1990 | 120 | 1,856 | 25,998 | 210 | 2,992 | 38,808 | 163 | 7,694 | 77,402 |
| 1991 | 95 | 1,816 | 20,240 | 240 | 2,872 | 28,268 | 319 | 5,404 | 62,477 |
| 1992 | 320 | 2,066 | 29,099 | 574 | 4,016 | 39,298 | 805 | 7,011 | 83,866 |
| 1993 | 241 | 2,323 | 30,172 | 780 | 3,600 | 39,392 | 826 | 9,495 | 77,955 |
| 1994 | 706 | 2,556 | 43,847 | 1,322 | 4,439 | 45,113 | 1,198 | 8,840 | 90,762 |
| 1995 | 1,032 | 3,568 | 44,877 | 1,984 | 5,372 | 42,767 | 2,625 | 6,303 | 86,345 |
| 1996 | 2,120 | 5,529 | 38,475 | 2,901 | 5,687 | 47,395 | 2,997 | 5,691 | 91,650 |
| 1997 | 3,154 | 6,210 | 42,913 | 3,013 | 6,381 | 49,159 | 3,706 | 8,048 | 90,835 |

NOTE: The first column for each airport represent the traffic through the hub-to-hub link, the second column the total traffic carried by NW/KL, and the third column the total traffic in the year

In the charts below, the *dashed line* represents the *total* annual traffic that flew on KLM and/or NW flights on all the legs of a passenger's itinerary¹, expressed as a percentage of the total transatlantic traffic originated at Nashville, Kansas City or St. Louis. This traffic is further divided into two types: the traffic that crossed the Atlantic through the hub-to-hub alliance link and the traffic that used any other NW or KLM flight. The former would include, for example, a passenger flying from Nashville to Berlin on a four-leg itinerary, connecting at both Detroit and Amsterdam, while the latter would include a passenger flying from Nashville to Paris crossing the Atlantic on a NW direct flight from Detroit to Paris. The *solid line* represents the evolution of the NW/KL *hub-to-hub traffic*, which reflects the impact of the alliance connectivity on the market share evolution. It includes the NW/KL traffic that crossed the Atlantic on Minneapolis-Amsterdam (MSP-AMS), Detroit-Amsterdam (DTW-AMS), Memphis-Amsterdam (MEM-AMS), or Boston-Amsterdam (BOS-AMS) flights. Finally, the *dotted line* represents the evolution of the *rest of NW/KL traffic* that did not use the hub-to-hub link connecting at Amsterdam.

¹ Includes traffic that flew on codeshare flights marketed by KLM or NW and operated by other carriers.

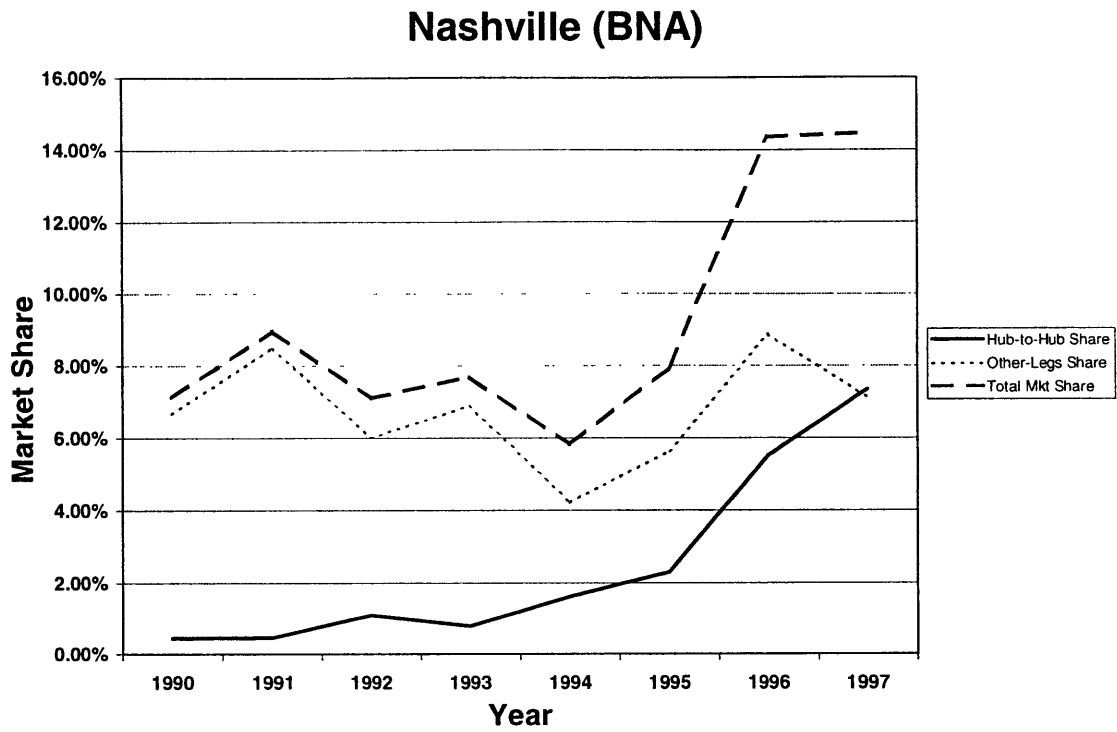

Figure 3.3. Northwest/KLM share of the transatlantic traffic out of Nashville, Tennessee

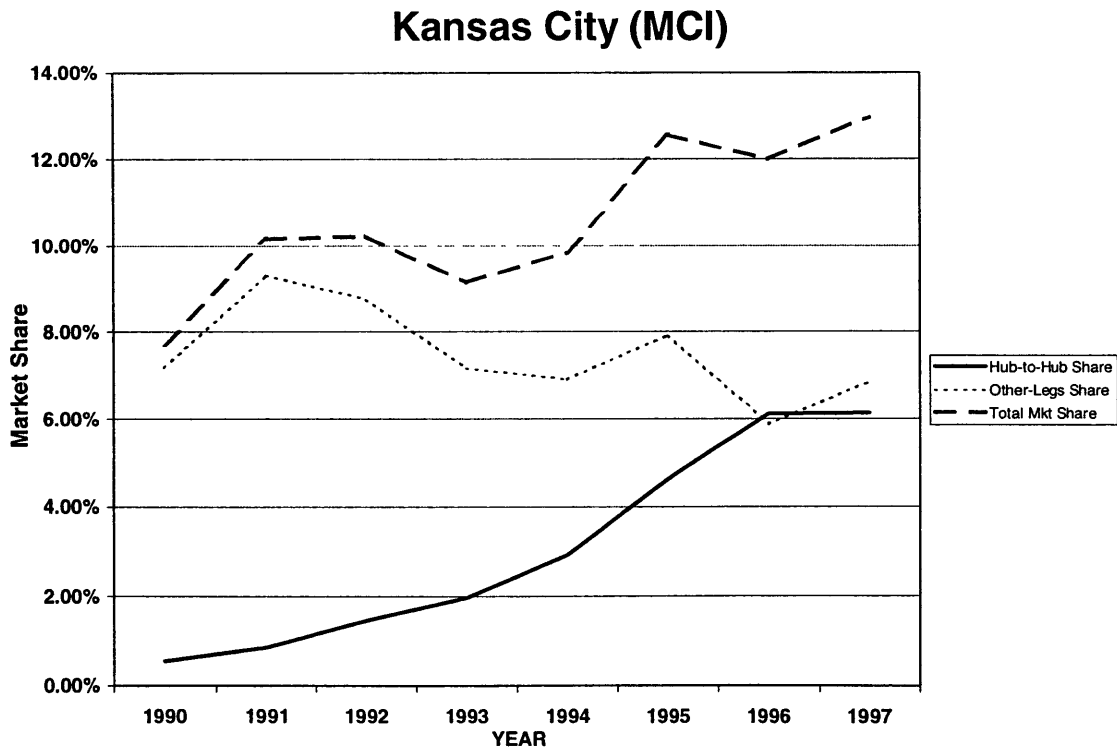

Figure 3.4. Northwest/KLM share of the transatlantic traffic out of Kansas City, Missouri

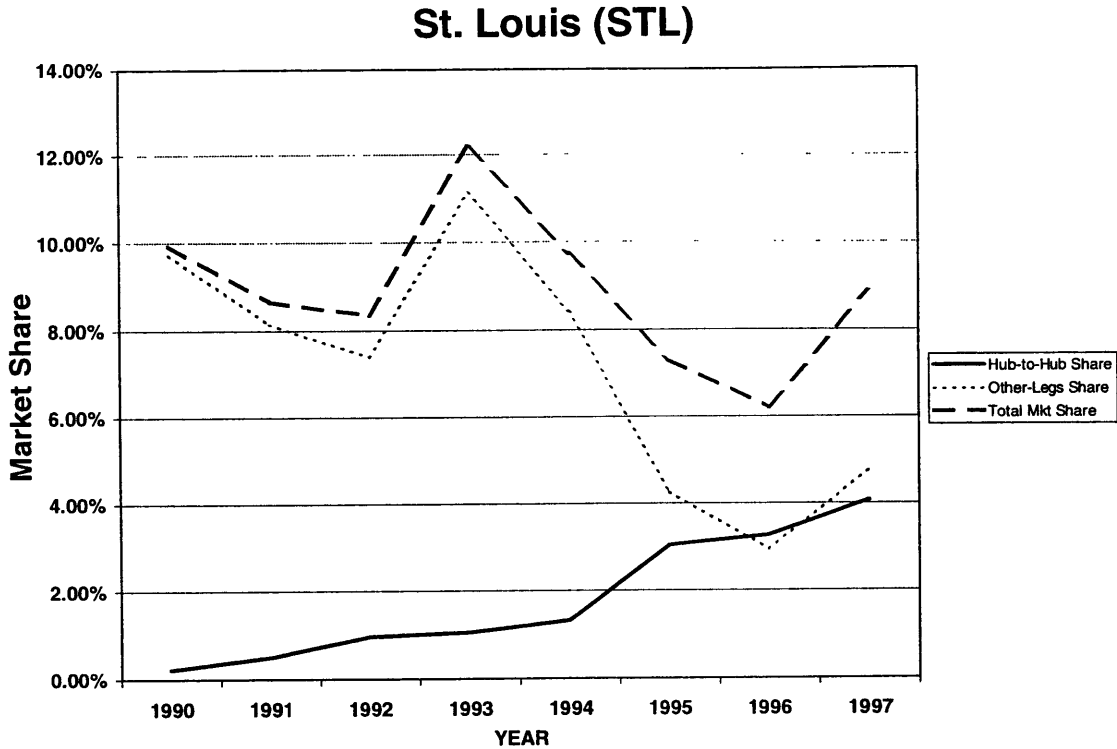

Figure 3.5. Northwest/KLM share of the transatlantic traffic out of St. Louis, Missouri

The above figures indicate very interesting results in terms of market share evolution. In the three of them, the market share of the hub-to-hub link, which will be called the “alliance link” from now on, is constantly increasing with time. This fact supports the hypothesis of this study that the level of network connectivity is a key factor in the increase of market share. In the three cases, the level of traffic carried through the alliance link (solid line) in 1997 reaches the same level as the traffic carried through non hub-to-hub transatlantic flights (dotted line).

The figures reveal a clear positive effect of the linkage between the NW and KLM networks through their hub-to-hub flights on the total transatlantic traffic carried by the two carriers. Such traffic reaches in 1997 the same level as that of the rest of non hub-to-hub flights, which carried traffic to the most popular European destinations, such as London, Paris or Frankfurt. This fact highlights the significant impact of the alliance for the two carriers, which, assuming a constant yield, would have provided half of the

NW/KL revenue from the international transatlantic traffic originating at these three airports in 1997.

It is interesting to note that while the market share of the alliance link increased over time, the market share of the NW/KL traffic through other non hub-to-hub transatlantic flights remained approximately constant or decreased over time. One could argue that this increase was partly due to a transfer of passengers from non hub-to-hub routes to the alliance link. However, a closer look to the data revealed that the portion of the traffic using the alliance link to fly to destinations where NW or KLM offered a direct flight from the US (that is, traffic shifting from the dotted line to the solid line) was extremely small.

Consequently, it can be concluded that the increase in market share shown in the figures is most likely due to a gain of traffic from capturing passengers from additional O&D markets offered through the alliance link. This fact highlights the importance of the alliance for both Northwest and KLM, since the increase in total market share for both carriers (dashed line), when it happens, is due to the formation of the alliance. And when it remains constant, in the case of St. Louis, the positive effect of the alliance connectivity cannot offset most of the decline in market share experienced in markets served by non hub-to-hub flights.

Another interesting finding from the analysis on market share involves the differences that exist between the three airports. St. Louis is a hub of TWA, and consequently, the competition experienced by the alliance link is greater for the traffic originating there. A clear sign of this higher degree of competition is the substantially lower market share of the NW/KL alliance link in St. Louis, which reaches a maximum of 4% in 1997, while reaching 6% and 7.5% in Kansas and Nashville. In addition, the market share of non hub-to-hub flights suffers a serious drop from 12% in 1993 to approximately 8% in 1997. Nevertheless, as Table 3.1 shows, the level of NW/KL traffic is higher for St. Louis than for Nashville and Kansas, since the former is a larger market and generates more traffic.

The significant drop in market share of non hub-to-hub NW/KL flights experienced in St. Louis could be a clear indicator of the importance of airline alliances in the 1990s. As alliances grow and international networks become connected by alliance hub-to-hub flights, it becomes more difficult for airlines to maintain their levels of market share in those markets served by non-alliance links.

The next step in the market share analysis was to observe the patterns in alliance success as the size of the O&D market increases. For that purpose, the average market share achieved by the alliance link in every O&D market belonging to a specific range of sizes was plotted as a function of the O&D market size. Figure 3.6 presents the results obtained.

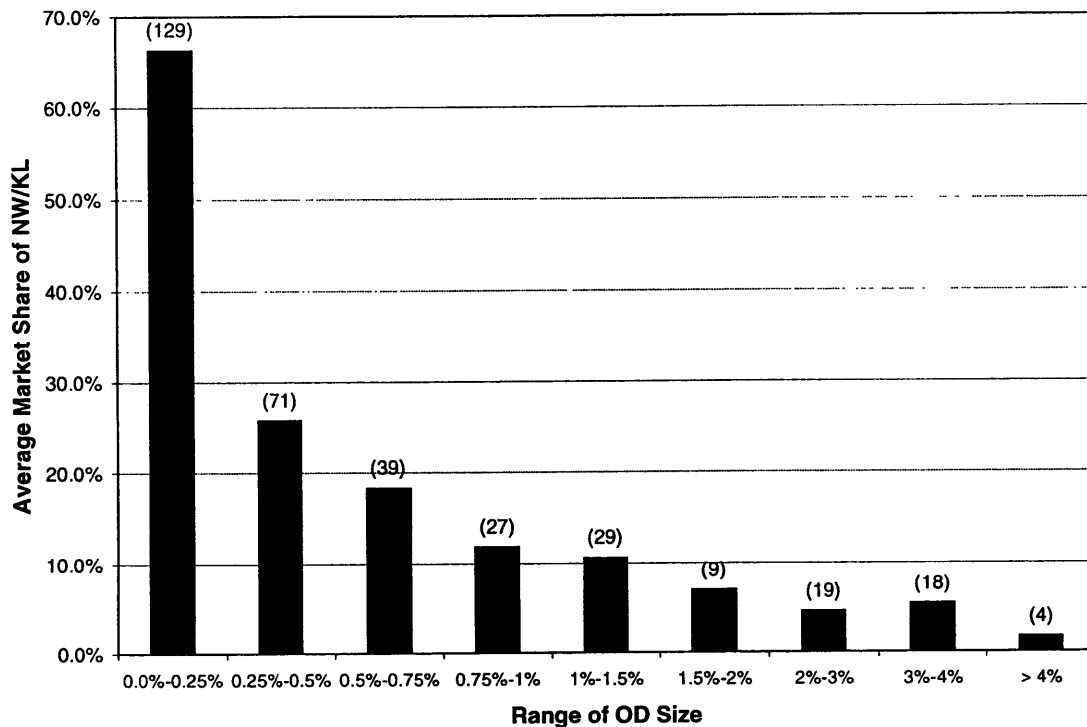

Figure 3.6. Impact of O&D market size on market share achieved by the alliance link. Traffic during the period 1990 to 1997

In the above chart, the horizontal axis represents the size of the O&D market expressed as the percentage traffic on each market with respect to the total annual transatlantic traffic leaving out of the same airport as the O&D market. The size of the O&D market

Nashville-Berlin (BNA-TXL) in the year 1995, for example, would be the total traffic of the market BNA-TXL in 1995 divided by the total traffic leaving Nashville in the same year, expressed as a percentage. The vertical axis represents the average market share for the NW/KL alliance link obtained as an arithmetic mean of the market shares from all the O&D markets of the sample that fall within a same range of sizes. In Figures 3.3 to 3.5, the measure for market share was at the aggregate level. Here, however, the measure of market share is at the O&D level. An O&D market with a market share of 70%, for example, indicates that 70% of the passengers that flew in this market during the year considered were carried by NW/KL through the alliance link. In the chart, the number in brackets indicates how many observations fell within each range of sizes.

It is important to clarify the sample of O&D markets used for the analysis. Of the entire period 1990 to 1997, only those markets and years in which there were passengers carried by NW/KL through the alliance link were selected. Each observation represents a given O&D market and a given year of the period considered. That is, each observation constitutes an O&D market-year. For example, the O&D market Nashville-Amsterdam provides 8 different observations, one for each year of the period 1990-97. Consequently, the first bar of the chart showing an average market share of 65% for the size range (0.0%-0.25%), indicates that, on average, NW/KL carried through the alliance link 65% of the passengers flying in each market that falls within the range of sizes (0.0%-0.25%) in a given year during the period 1990 to 1997.

The figure indicates a clear trend towards smaller market shares as the size of the O&D market increases. This result was expected, since in those markets with a high level of traffic (larger size), the degree of competition is expected to be higher due to the presence of competing alternatives more attractive for the passenger. On the contrary, for certain small markets where competing airlines do not have a strong presence, the alliance may carry all the passengers flying on the market, and therefore, achieve a 100% market share. For example, in 1997, NW/KL carried all the 20 passengers that flew in the market St. Louis-Antwerp (Belgium), and consequently, the market share

for this market-year is 100%. This result highlights an important conclusion: The alliance link is relatively more effective for small O&D markets than for large O&D markets, in terms of market share.

To achieve higher market shares in small markets does not imply that those markets are most valuable for the alliance. A smaller market share in a market with more traffic can provide significantly more revenue to the alliance than a higher market share in a small market. Consider, for example, the St. Louis-Antwerp (STL-ANR) and the St. Louis-Amsterdam (STL-AMS) markets in 1997. The latter, with a larger market size of 2.49% and a smaller market share of 39%, provides significantly more traffic (882 passengers) and therefore revenue than the market STL-ANR, with a greater market share of 100% and smaller market size of 0.02% (20 passengers). To evaluate the relationship between the traffic value of the markets and the size of the market, the levels of annual traffic carried by NW/KL in each market expressed as a percentage of the total transatlantic traffic carried by NW/KL were calculated and plotted on a chart. The markets with destination Amsterdam were excluded in order to concentrate on the effects of the alliance link on beyond-the-hubs markets. Figure 3.7 summarizes the results.

In Figure 3.7, the vertical axis represents the average number of passengers carried by NW/KL through the alliance link on a given market and year, expressed as a percentage of the total transatlantic traffic carried by NW/KL out of the same originating airport as the market. The average traffic has been estimated as the arithmetic mean of the traffic percentages from all the observations that fall within each of the size ranges.

The chart indicates that, indeed, the smallest markets, even though they are the ones where the alliance achieves the highest market share, do not provide the same level of traffic as larger markets. This result cannot extrapolate to all the markets served by the entire alliance network, but can be generalized by saying that there is a range of medium-size markets where the alliance achieves the maximum gains from the alliance.

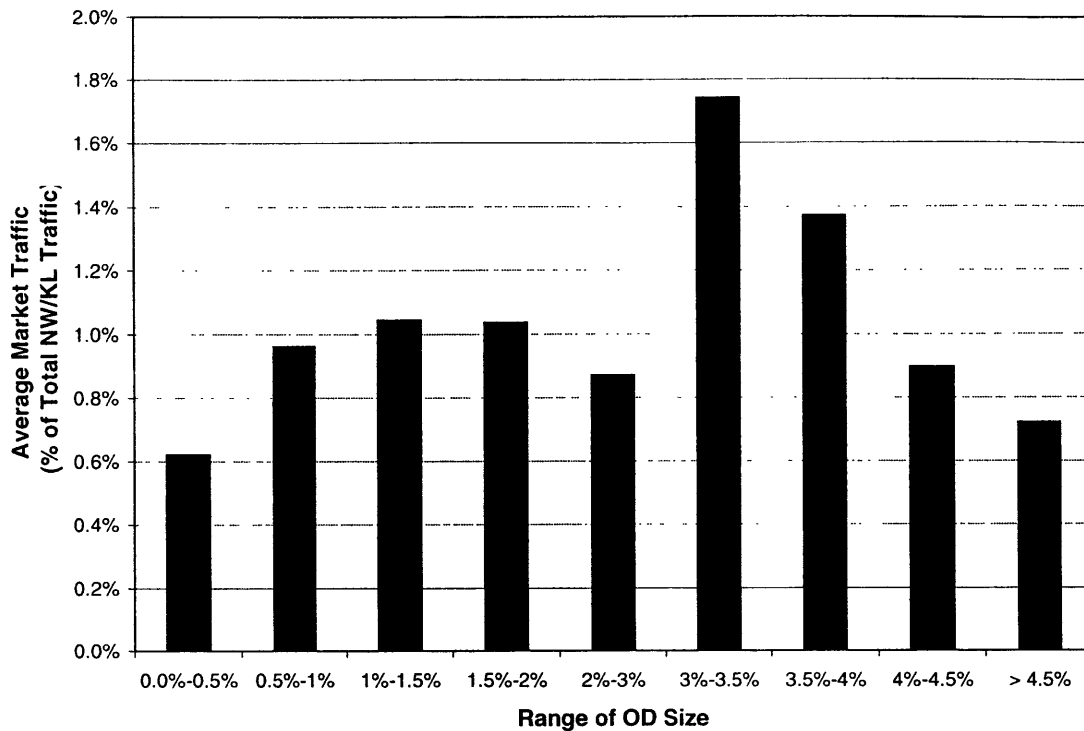

Figure 3.7. Effect of OD size on the NW/KL traffic carried by market. O&D market-year observations on the period 1990-1997

In this section, the evolution of market share for the NW/KL alliance on the transatlantic traffic originating at three different airports has been studied. It has been shown that the alliance hub-to-hub connectivity has a decisive impact on the increase of NW/KL overall market share of traffic crossing the transatlantic. The next step is to determine a way to measure the degree of connectivity between the two networks and analyze how such connectivity affects the alliance's ability to gain market share.

3.5. Accessibility: a Metric for Alliance Network Connectivity

To measure how well connected the two networks of the alliance are it is important to consider not only pure network variables, but also other level of service variables regarding the quality of service provided through the alliance link. Since the objective is to find how the alliance connectivity affects market share, it is needed to define a

measure of connectivity that incorporates elements driving demand. Therefore, LOS variables have been included in the metric for connectivity defined in this chapter.

Such a metric has been defined as **accessibility**. Accessibility has been constructed as a measure of the connectivity provided by the alliance in each O&D market served through the hub-to-hub link, including in its formulation several level-of-service variables. These are the frequency of service, the seat-capacity provided, the convenience of the connections at the hubs, and the number of total stops included in the hub-to-hub itinerary. However, it does not include other frequently used transportation variables such as in-flight travel time, circuitry, airfares, or quality of passenger service.

First, to come up with a measure of the travel time for an O&D is difficult, since there are different possible combinations to make the trip. In addition, in-flight travel time is so such a critical factor in transatlantic markets. On the contrary, the waiting time at the connecting hubs becomes more important, and therefore its effect into the accessibility equation has been included through a measure of the convenience of the connections at the hubs. Furthermore, the fact that a destination is far away and the travel time to reach it is long should not imply that the market share should be smaller than for a closer destination, since the travel time will be equally long for the alliance and the competing carriers. In the analysis the level of circuitry provided by the alliance link is also ignored, under the assumption that circuitry should not be a big factor for transatlantic markets.

The fact of not including the fare level offered by the alliance can be controversial. However, the analysis is intended to focus on those variables that are purely operational. In addition, the fares published by the company cannot be considered as the fares that were actually offered to customers, which are more a consequence of seat inventory management than of an independent pricing decision process itself. In fact, because the seat-capacity is included into the accessibility formulation, there is a relationship between accessibility and the actual level of fares offered to customers. The greater the number of seats allocated to the hub-to-hub link, the easier would be for

the airline to open low fare classes and therefore offer cheaper seats to customers. In turn, the higher the accessibility the lower the fares.

Other important variables related to the quality of passenger service, such as the on-board quality of service and frequent flyer programs, have not been included into the accessibility formulation because they do not represent operational variables. In addition, they are soft variables that are very difficult to measure, and most airlines today offer similar passenger services and frequent flyer programs.

Given this discussion of the relative importance of each variable, the next step is to construct the measure of network connectivity. The accessibility provided by the alliance to each O&D market served through the hub-to-hub link is defined as follows:

$$ACCESS^{OD} = \sum_{i \in F_{H-H}} access_i^{OD}, \quad [3.1]$$

where $ACCESS^{OD}$ is the accessibility provided by the alliance hub-to-hub link to the O&D market OD , F_{H-H} is the set of hub-to-hub transatlantic flights of Northwest and KLM, which are those flights between the city pairs Detroit-Amsterdam, Minneapolis-Amsterdam, Memphis-Amsterdam, and Boston-Amsterdam. Finally, $access_i^{OD}$ is the accessibility provided by the hub-to-hub flight i to the market OD , and is defined as follows:

$$access_i^{OD} = \min \left\{ \sum_{j \in F_{O-H}} cap_j \cdot f_{OH}(t_{j-i}), \sum_{k \in F_{H-D}} cap_k \cdot f_{HD}(t_{k-i}), cap_i \right\} \cdot f_s(n_i^{OD}), \quad [3.2]$$

where F_{O-H} is the set of Northwest domestic flights from origin O (assuming it is located in Northwest's network) to the Northwest hub H , where the transatlantic flight i originates, F_{H-D} is the set of KLM domestic flights from KLM's hub H (Amsterdam) to the final destination D , and cap_j is the capacity of each flight j expressed as the number of seats on the aircraft. $f_{OH}(\)$ is the connecting convenience function defined for the connection at the Northwest hub. $f_{OH}(\)$ is a function of t_{ji} , the difference between the

time at which the transatlantic flight i is scheduled to depart and the time at which the flight j is scheduled to arrive at the hub. The same applies for $f_{HD}(\)$ in reference to the connection at Amsterdam, KLM's hub. Finally, $f_s(n_i^{OD})$ is the weight function for the number of stops, which is a function of n_i^{OD} . This variable represents, for each hub-to-hub flight i connecting the market OD, the minimum number of flight-legs required to fly on that market through the flight i . For destinations beyond Amsterdam, n_i^{OD} is 3 if the hub-to-hub flight is a non-stop flight, or 4 if it has an intermediate stop (for example, in Boston). This is true if it is assumed that there are always non-stop flights from the originating airports to the Northwest's hubs, and from Amsterdam to the final destinations.

A critical step in the definition of accessibility is the establishment of the connecting convenience functions. They must be defined in a way that captures the convenience for passengers of the connection at the hubs when making a transatlantic trip. Figure 3.8 illustrates the general shape of the function used.

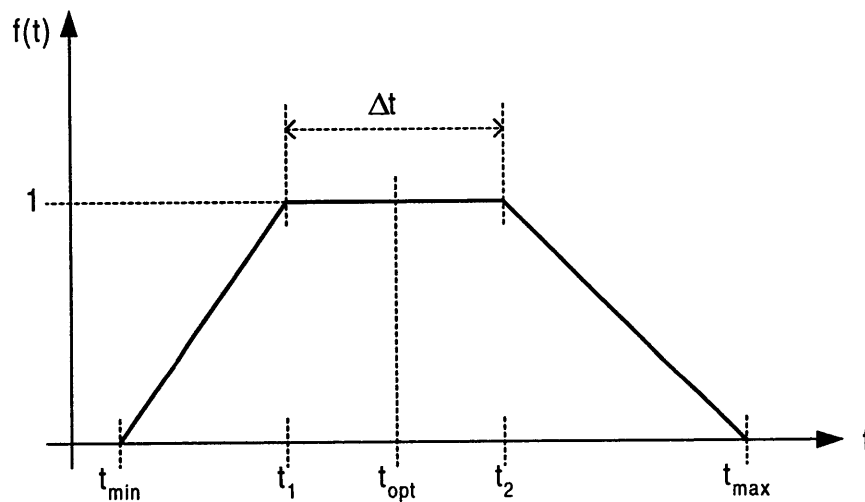

Figure 3.8. Definition of the connecting convenience function

In the above figure, five critical time parameters that define the shape of the connecting convenience function are presented. The most important parameter is t_{opt} , which represents the “optimal” connecting time from the passenger’s point of view between the arrival of the connecting flight and the departure of the hub-to-hub flight, or vice

versa. All the connecting flights that fall within a time interval Δt around t_{opt} have a high “connectivity value” and the connecting convenience function is 1 for them. Connecting flights that fall outside this time interval have a smaller value of the connecting convenience function, reaching zero for those flights that fall outside the time interval (t_{min}, t_{max}) . Table 3.2 shows the values that have been considered for the five time parameters in the analysis. These numbers have been determined based on logical assumptions and common judgement. t_{min} is the minimum time interval required to make a feasible connection. The Official Airline Guide (OAG) publishes official values for the minimum connecting times at every airport worldwide. Such values have been used as a reference in the analysis to estimate t_{min} . On the other hand, t_{max} represents the maximum time interval up to which the connection still provides a significant utility to the passenger. It is assumed that any flight that falls out of the window (t_{min}, t_{max}) will not provide significant utility to the passenger, and therefore, will not contribute to the accessibility provided by the hub-to-hub flight considered. Because the value of t_{opt} is subjective, the interval Δt is given as a confidence interval so that all the flights falling within such interval provide the same level of convenience.

Table 3.2. Time parameters of the connecting convenience functions

| Time parameters | F_{OH} | f_{HD} |
|-----------------|----------|----------|
| t_{min} | 0:45 | 1:00 |
| t_1 | 1:00 | 1:10 |
| t_{opt} | 1:30 | 1:45 |
| t_2 | 2:30 | 2:45 |
| t_{max} | 5:00 | 5:15 |
| Δt | 1:30 | 1:30 |

All times are expressed in *hrs:min* format

Finally, $f_s()$ is the function that takes into account the inconvenience of having an additional stop in the itinerary. For most O&D markets in the analysis, the number of flight-legs, n_i^{OD} , will be 3. The exceptions are those markets with Amsterdam as destination, where the number of legs becomes 2, and those transatlantic flights that have an intermediate stop before crossing the Atlantic, where the number of legs becomes 4. This is the case, for example, of a NW flight from Minneapolis to Amsterdam that makes an intermediate stop at Boston. The shape of the function $f_s()$

must be decreasing with the number of stops, since as the number of stops increases the utility, and therefore, the accessibility provided to customers decreases. It is a common practice to assume an exponential decay to account for the diminishing of utility as the number of stops increases. Therefore, a negative exponential function as been used for $f_s()$, as it is shown in the graph below.

$$f_s(n_i^{OD}) = \exp(-n_i^{OD}) \quad [3.3]$$

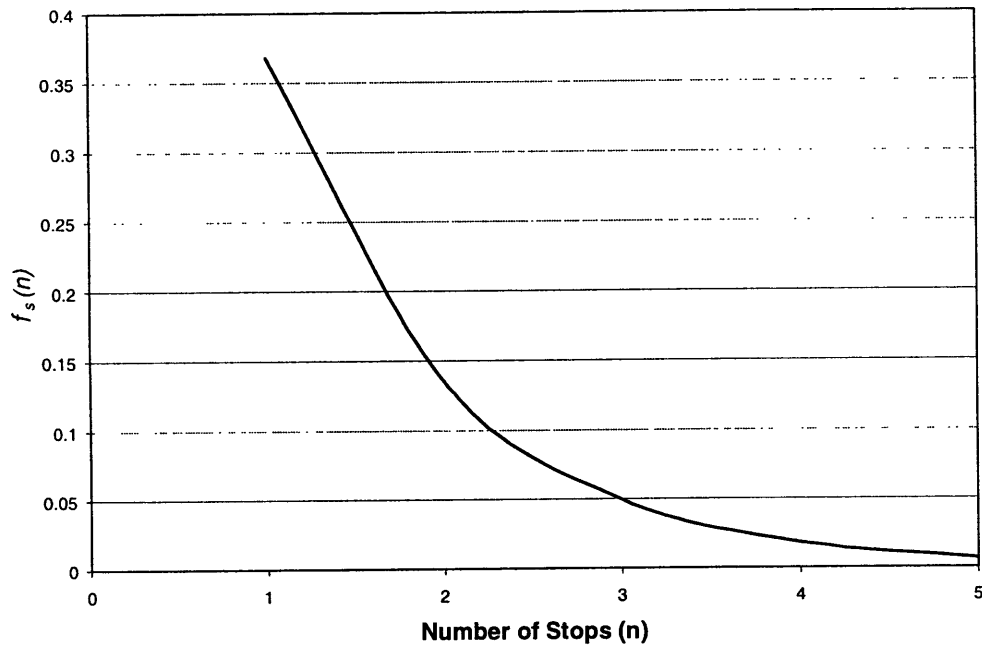

Figure 3.9. Effect of the number of stops in the accessibility formulation, $f_s(n)$

The figure on the next page illustrates through a “schedule map” the definition given for alliance accessibility in the O&D market Nashville-Vienna (BNA-VIE). The total alliance accessibility provided in this market would be the sum of the accessibilities provided by each hub-to-hub flight. Consider the hub-to-hub flight “h” presented in Figure 3.10. Following the notation of Equation 3.2, the accessibility provided by this flight to the O&D market BNA-VIE would be given by the following equation:

$$access_h^{BNA-VIE} = \min \left\{ \begin{aligned} &cap_a \cdot f_{OH}(t_{ah}) + cap_b \cdot f_{OH}(t_{bh}) + cap_c \cdot f_{OH}(t_{ch}) + cap_d \cdot f_{OH}(t_{dh}), \\ &cap_k \cdot f_{HD}(t_{hk}) + cap_l \cdot f_{HD}(t_{hl}) + cap_m \cdot f_{HD}(t_{hm}), cap_h \end{aligned} \right\} \cdot f_s(3)$$

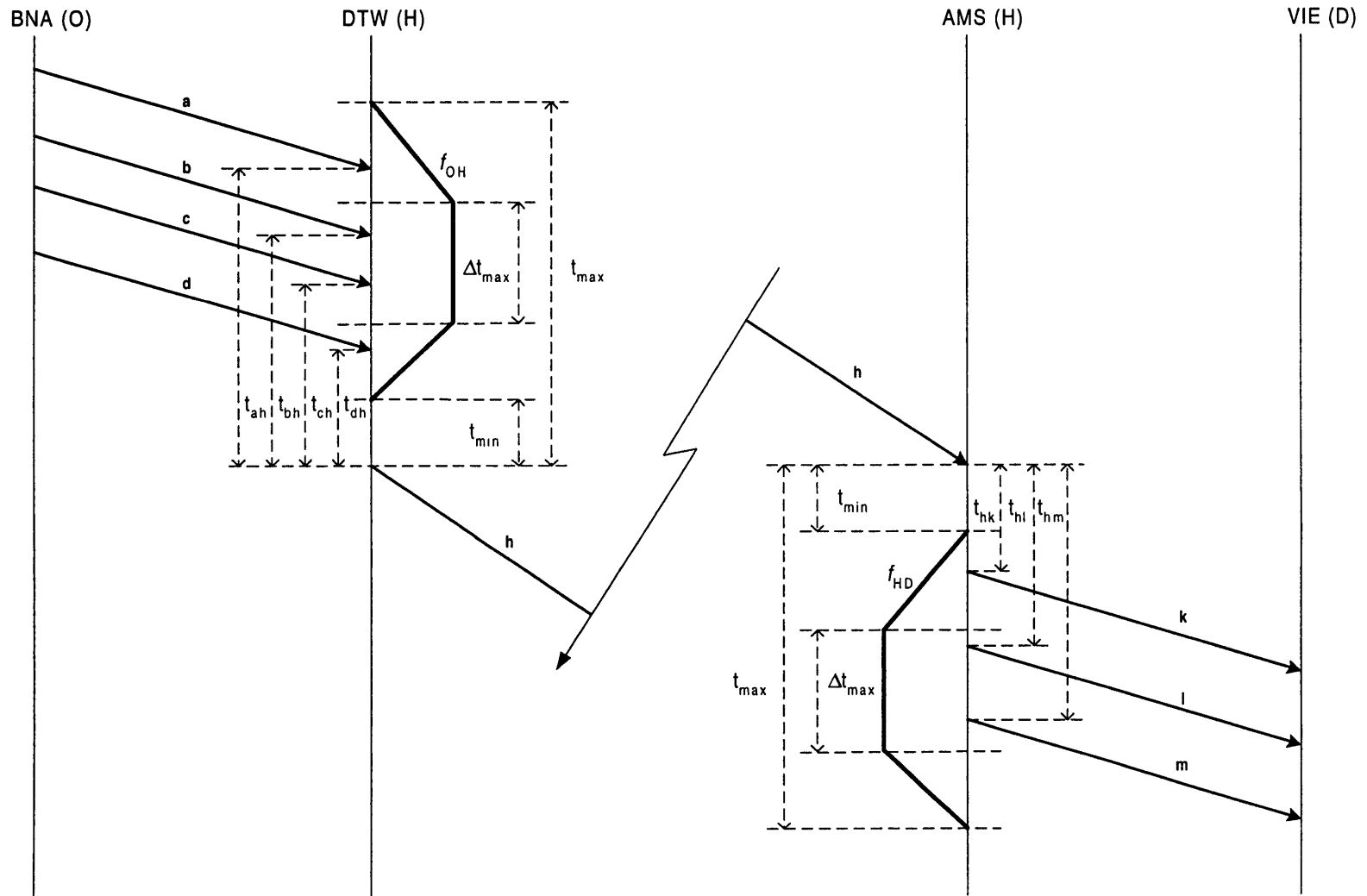

Figure 3.10. Definition of accessibility

3.6. Relationship between Accessibility and Market Share

The measure of network connectivity defined in Section 3.5 was used to compute the accessibility for every O&D market and year in which Northwest/KLM carried traffic through the alliance hub-to-hub link. The evolution of such connectivity was first compared with the evolution of market share, as described in Section 3.6.1. Because the level of network connectivity is not the only factor affecting the evolution of market share, a regression model is developed in Section 3.6.2. This model incorporates additional competitive variables to explain the changes in market share. The goal is to find a more realistic relationship between accessibility and market share. Finally, the effects of two different measures of network connectivity such as frequency and accessibility are compared, to illustrate the greater impact of accessibility.

3.6.1. Evolution of Market Share and Accessibility

The accessibility provided by the NW/KL hub-to-hub link for each of the three US airports in the analysis was estimated for every year. It was determined as the average accessibility among all the O&D markets served by the hub-to-hub link with one of the three airports as a common origin. The average value was obtained by weighting the accessibility to each O&D market defined in Section 3.5 by the traffic that NW/KL carried on each O&D market. Therefore, a measure of accessibility provided to the transatlantic traffic originating at each of the three airports was obtained on an annual basis, and it was possible to compare the evolution of such accessibility with the evolution of market share at the aggregate level. Figures 3.11 to 3.13 illustrate the results obtained.

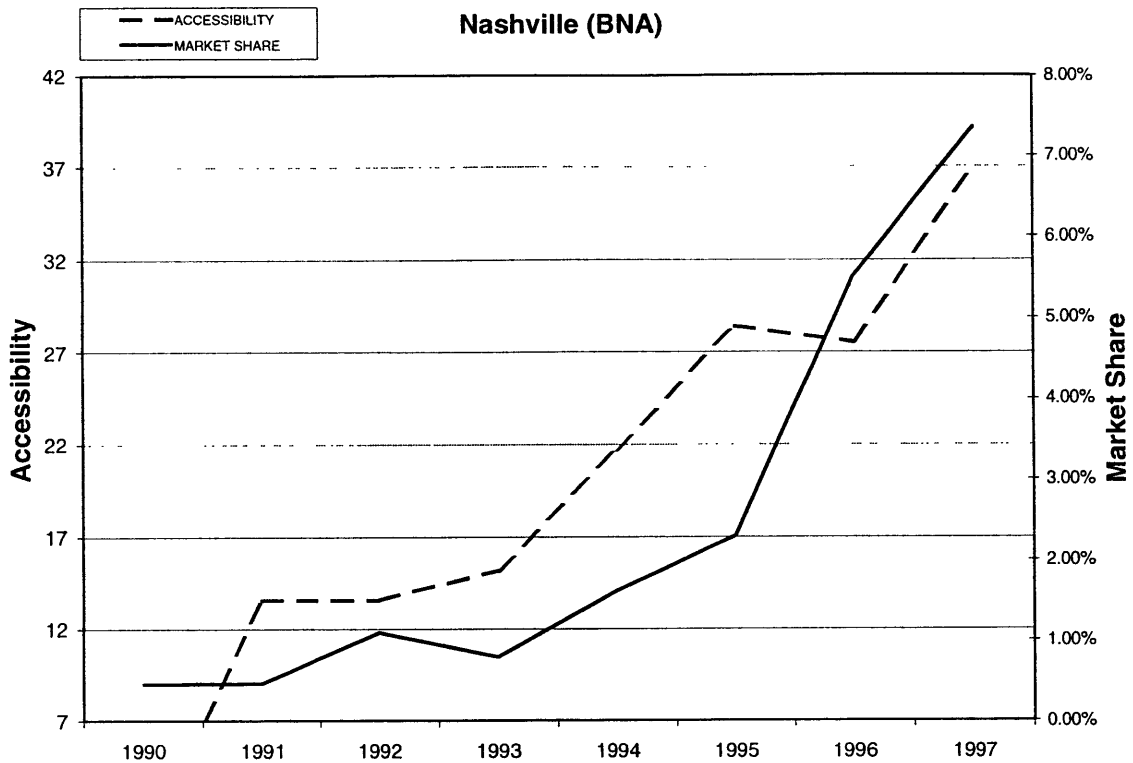

Figure 3.11. Evolution of accessibility versus market share in Nashville

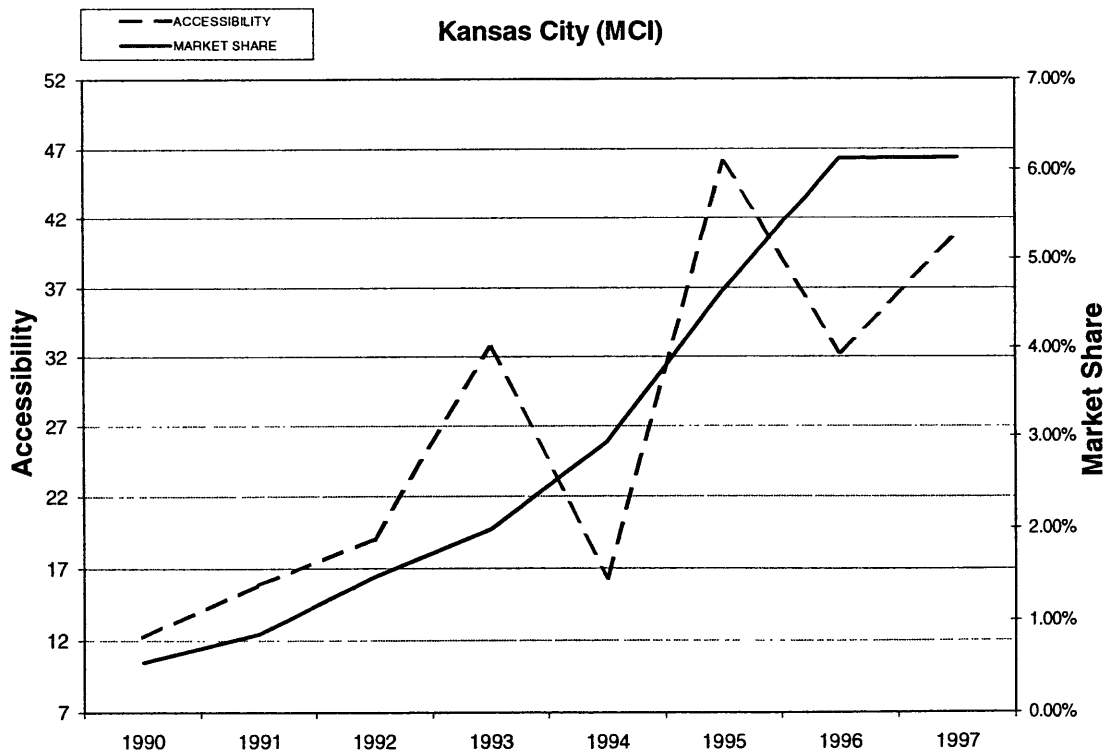

Figure 3.12. Evolution of accessibility versus market share in Kansas City

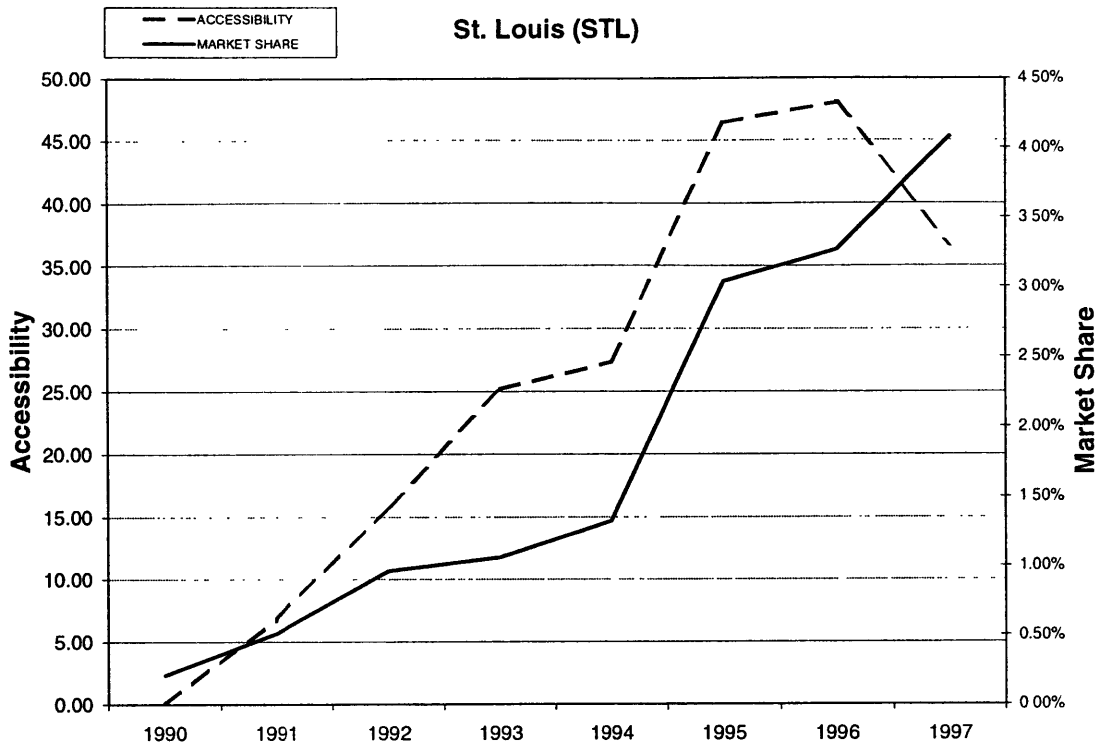

Figure 3.13. Evolution of accessibility versus market share in St. Louis

The figures presented above indicate a general tendency of increasing market share as accessibility increases. However, there is a certain degree of disparity between the two curves. The main cause of the differences found between the two curves is that the accessibility provided by the alliance link is not the only variable affecting the market share. The degree of competition in every market is a very important variable as well that should also be taken into account in the evolution of market share presented above. To address this problem, a more complex model is developed in Section 3.6.2.

In addition, the accessibility of the O&D markets with Amsterdam as the final destination are significantly higher than in the rest of the markets. Because the former markets are the ones with the highest levels of traffic carried by NW/KL through the alliance link, their weight in the computation of the average accessibility is significant, and their inclusion results in a significant distortion of the average measure. To solve this problem, the markets with Amsterdam as final destination were taken out of the average accessibility computation. The results are shown in Figures 3.14 to 3.16.

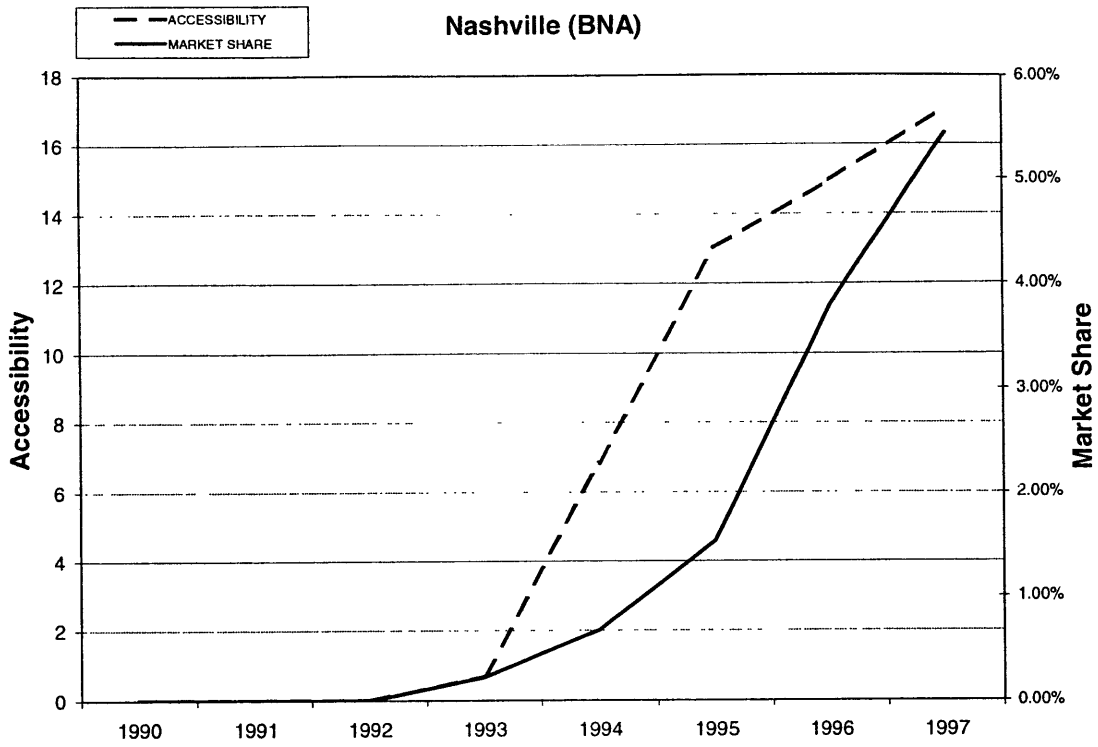

Figure 3.14. Evolution of accessibility versus market share, Nashville. Destinations beyond Amsterdam

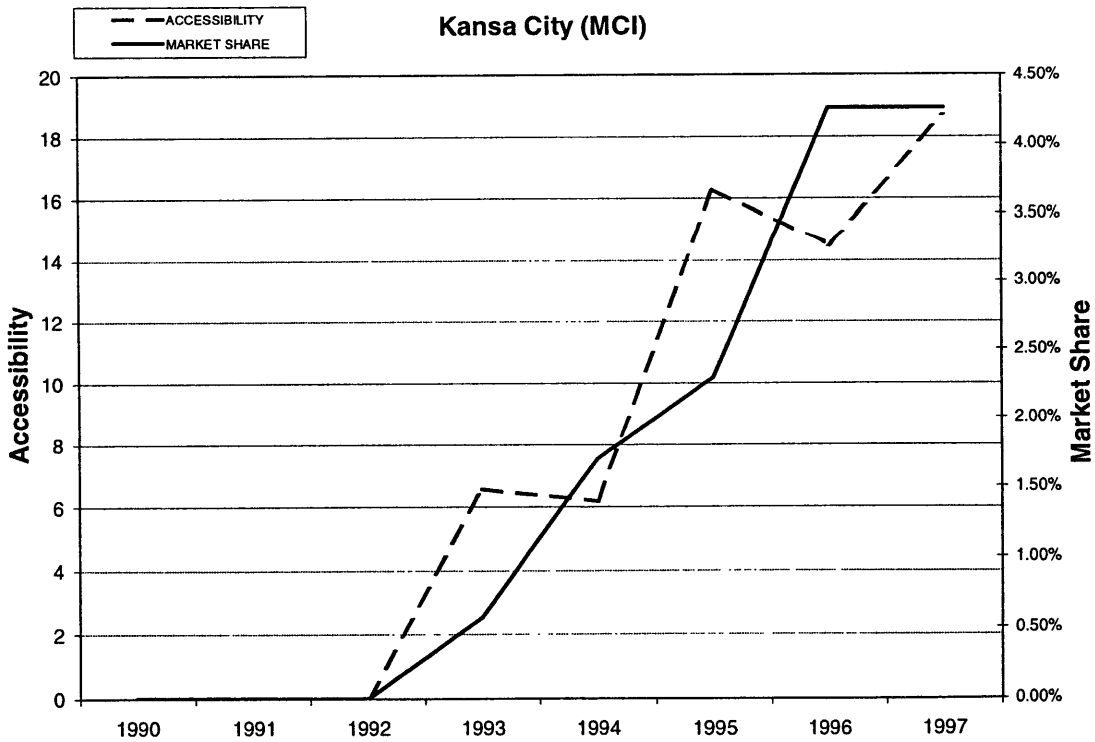

Figure 3.15. Evolution of accessibility vs. market share, Kansas City. Destinations beyond Amsterdam

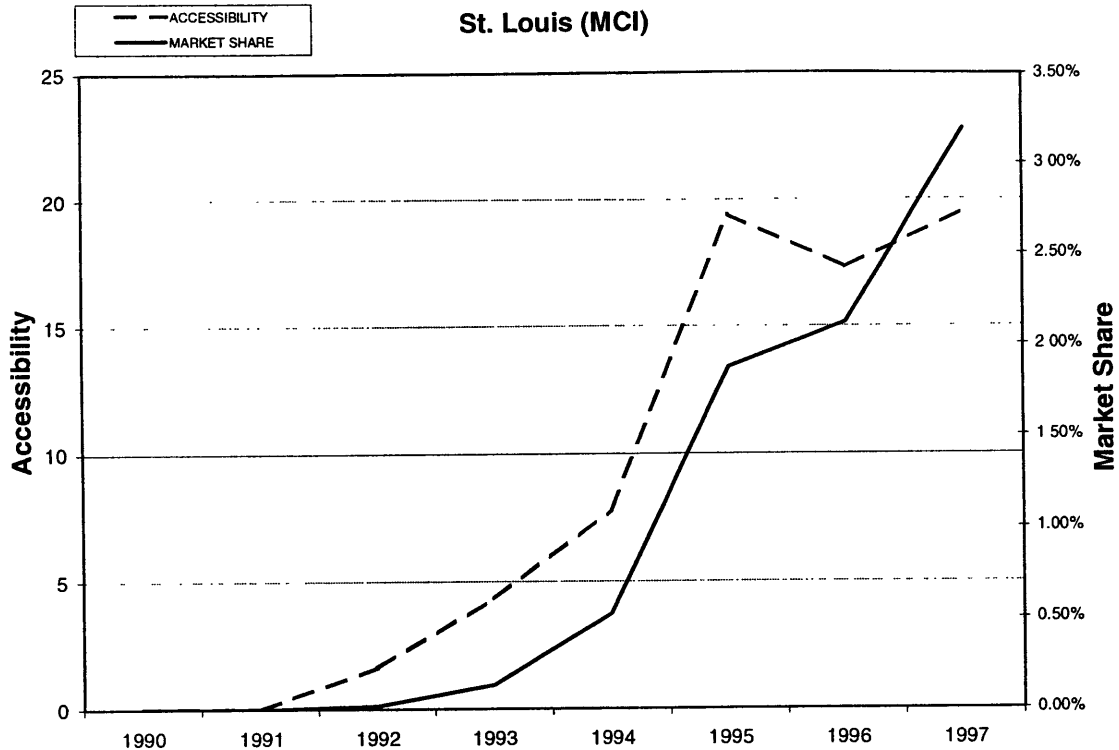

Figure 3.16. Evolution of accessibility versus market share, St. Louis. Destinations beyond Amsterdam

The two curves presented in each of the above figures indicate a higher degree of correlation than before. This improvement was expected once the distorting effect of Amsterdam had been eliminated. Note that the market share levels found in these plots are lower than in the previous ones.

Because the average accessibility has been estimated as a weighted average for those markets in which NW/KL carried a portion of the traffic, those years in which the alliance only carried passengers to Amsterdam through the hub-to-hub link (which equals to zero market share in the above plots) present a null accessibility. The contrary does not hold, since in years with market share greater than zero, the accessibility can remain null. In this case, a zero accessibility reflects the fact that there were no connecting flights from the origin to the Northwest hub or from Amsterdam to the final destination that fell within the time window (t_{\min}, t_{\max}) of the connecting convenience functions.

For example, in Figures 3.11 and 3.13, the year 1990 shows a null accessibility for both Nashville and St. Louis, while the market share is greater than zero. This is due to the fact that in 1990 the only hub-to-hub flight departed from Boston, while there were no NW direct flights from Nashville and St. Louis to Boston. Therefore, the positive market share comes from passengers that flew to Boston on two-leg itineraries before boarding the transatlantic flight leaving out of Boston. It is important to note that the contribution of domestic connecting itineraries both previously and subsequently of the hub-to-hub link on Northwest's and KLM's networks respectively, has not been considered in the definition of accessibility.

Since the markets with Amsterdam as final destination present so distinct an accessibility, it was interesting to analyze the evolution of market share versus accessibility in such markets alone. Thus, the traffic on such markets was isolated and analyzed. The results are presented in Figures 3.17 to 3.19.

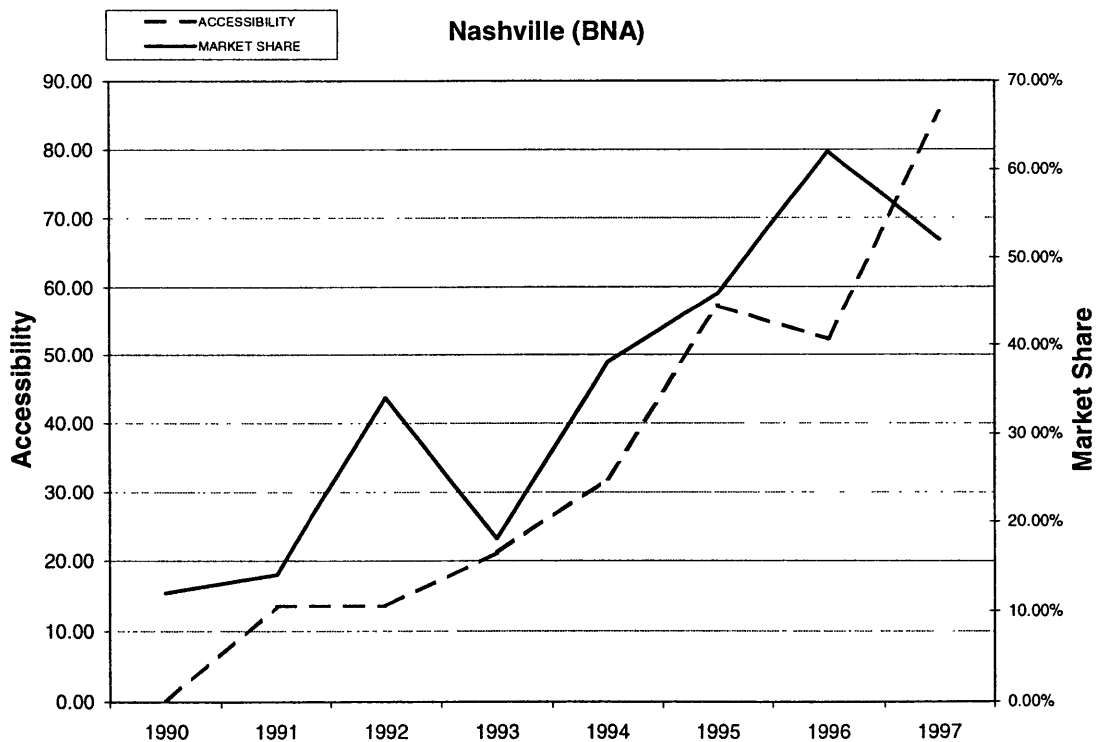

Figure 3.17. Evolution of accessibility versus market share in the market Nashville-Amsterdam

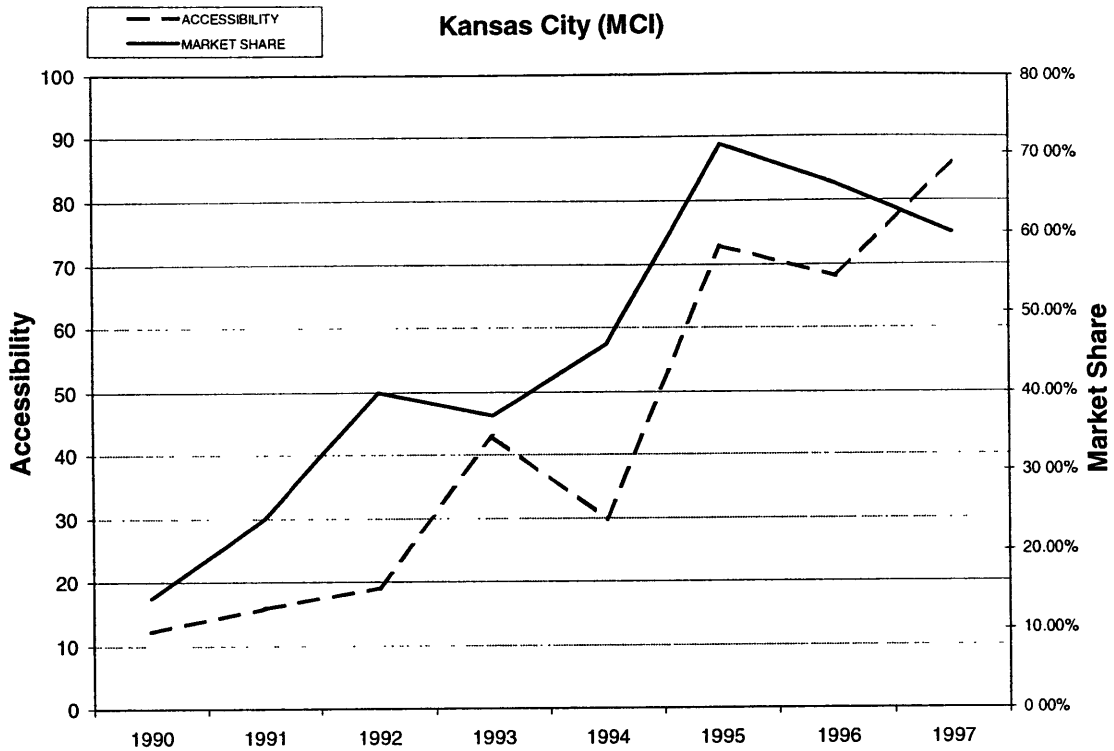

Figure 3.18. Evolution of accessibility versus market share in the market Kansas-Amsterdam

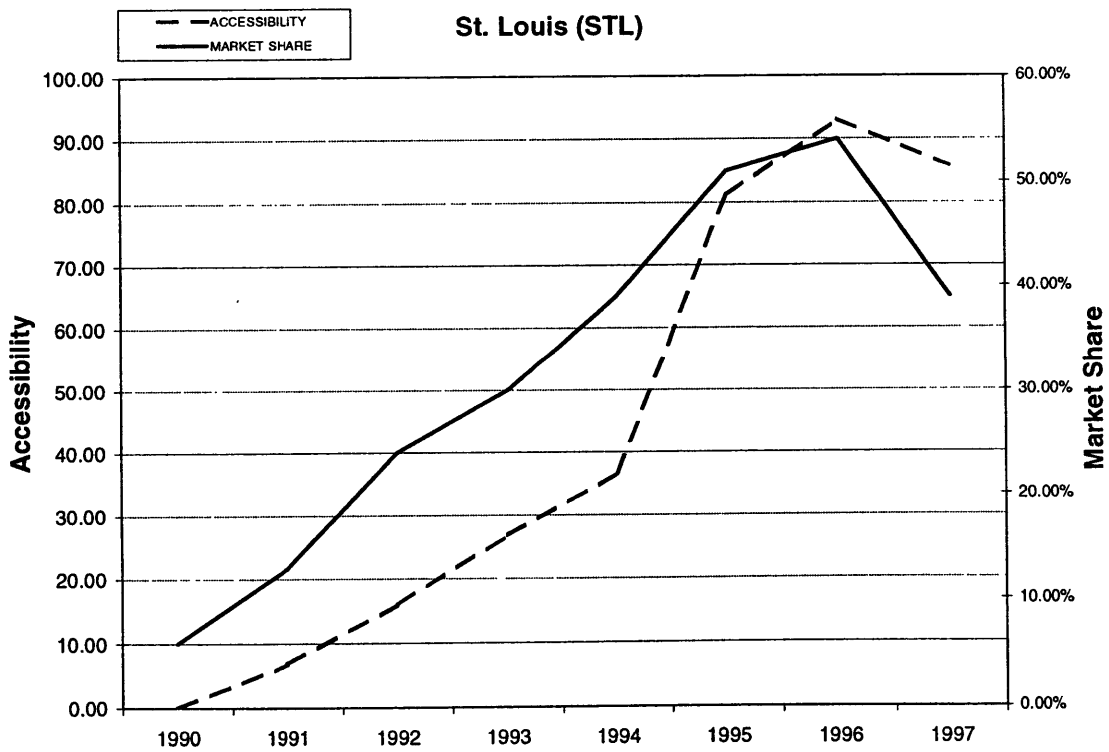

Figure 3.19. Evolution of accessibility versus market share in the market St. Louis-Amsterdam

As observed in the previous set of figures—when Amsterdam was excluded of the analysis—the above figures also present a higher degree of correlation than the first set of plots. However, for one market individually, the correlation between accessibility and market share is highly affected by the actions of competing carriers in the market, and cannot be fully appreciated from the simple plots presented above. Therefore, in the next section, a regression model is introduced in order to take into account the level of competition in each market. The model estimates the correlation between accessibility and market share based on individual O&D market data.

3.6.2. The Regression Model

As discussed above, a more complex model that takes into account most of the variables affecting the evolution of market share in specific markets can be used in order to better identify the effect of accessibility on market share. For that purpose the model presented below was developed.

Model Equation

$$\begin{aligned}
 MS = & a_0 + a_1 \cdot NCOMP1 + a_2 \cdot NCOMP2 + a_3 \cdot NCOMP3 \\
 & + a_4 \cdot NCOMP4 + a_5 \cdot INTER2 + a_6 \cdot INTER3 + a_7 \cdot INTER4 \quad [3.4] \\
 & + a_8 \cdot AMSDEST + a_9 \cdot ODSIZE + a_{10} \cdot ACCESS
 \end{aligned}$$

Definition of Variables

MS: Market share of the traffic carried by NW/KL through the hub-to-hub link—i.e., traffic stopping at Amsterdam—out of the total annual traffic for every O&D market-year of the sample. It is expressed as a percentage value.

NCOMP1: Number of non-interlining competing itineraries that actually carried some traffic during the year considered, which consisted of a non-stop flight. Itineraries are differentiated based on the carriers operating the flights and

the actual paths followed by passengers. For example, two different carriers having carried passengers on non-stop flights from Nashville to Amsterdam in a given year represent two different competing itineraries to be added to *NCOMP1* in the regression equation. It is an integer variable.

NCOMP2: Same variable as *NCOMP1*, but for the number of competing itineraries consisting of 2 legs. Here, Competing itineraries include itineraries flown by both two alliance partners (for example BA/US) and single carriers (itineraries consisting on legs operated by the same carrier). It is also an integer variable.

NCOMP3: Same variable as *NCOMP2*, but for the number of competing itineraries consisting of 3 legs. It is an integer variable.

NCOMP4: Same variable as *NCOMP2*, but for the number of competing itineraries consisting of 4 legs. It is an integer variable.

INTER2: Dummy variable {0,1}. Its value is 1 when part of the traffic on the O&D market-year considered flew through inter-line connections consisting of itineraries of two flight-legs. It is 0 otherwise.

INTER3: Dummy variable {0,1}. Same as *INTER2*, but for inter-line connections consisting of three-leg itineraries.

INTER4: Dummy variable {0,1}. Same as *INTER2*, but for inter-line connections consisting of four-leg itineraries.

AMSDEST: Dummy variable {0,1}. Its value is 1 for those O&D markets that have Amsterdam as the final destination. It is 0 otherwise.

ODSIZE: Represents the size of the O&D market in terms of its traffic volume in the year considered. It is expressed as the percentage traffic on the O&D

market with respect to the total transatlantic traffic originated in the same year out of the same airport as the O&D market considered.

ACCESS: Accessibility provided by the alliance to the O&D market considered, in the year considered, as defined in section 3.5.

It is important to recognize that, in the above definitions, the “itineraries” considered for each O&D market are given by the existence of traffic flying through such itineraries any time during the year of the observation. They do not necessarily imply a combination of regular flights.

The model presented above incorporates new variables that capture the intrinsic characteristics of every specific market, such as the level of competition or its size. The influence of competition has been separated based on the number of legs of competing itineraries, since competing itineraries with fewer number of legs are expected to provide stronger competition than itineraries with more number of legs. In addition, the level of competition has been differentiated depending on whether it was one carrier or a combination of allied partners that carried the traffic, or, on the other hand, it was a combination of non-allied carriers through inter-line itineraries. This distinction is made because inter-line itineraries are expected to provide less competition than on-line or alliance itineraries.

It is very important to recognize the fact that the level of competition reflected in the model is based, not on the potential competing service scheduled for every O&D market, but on the actual traffic that flew on competing itineraries. That is, if a given carrier had offered service for a particular market, but no passengers had chosen to fly that carrier, the competing service offered by such carrier will not appear in any of the variables of the model in that market.

The variable AMSDEST has been included in the model to account for the fact that markets with Amsterdam as destination are distinct markets, with significantly higher than average levels of accessibility. In addition, the fact that Amsterdam is a KLM hub introduces the hub-dominance effect over demand.

Another important characteristic of the model is that the only level of service variable that has been included is the accessibility. However, following the discussion of Section 3.5, the metric for network connectivity defined as accessibility incorporates many operational effects that influence or are influenced by typical LOS variables, such as airline fares. In addition, it would be extremely complicated to come up with realistic measures of soft variables, such as the quality of passenger service.

Results of the Model

All the variables presented in Equation 3.4 were calculated for every observation of the analysis. The sample of observations consisted of the set of O&D market-years in which Northwest and/or KLM carried outbound traffic through the hub-to-hub link out of one of the three airports considered in the analysis. It totaled 367 observations. Ordinary Least Squares estimation (OLS) was applied to the model in order to estimate its coefficients. The results are presented in Table 3.3.

Table 3.3. Results from the OLS regression

| Variable | All markets | | Traffic>50pax | | Traffic>100pax | |
|-------------------------------|-------------|------------|---------------|------------|----------------|------------|
| | Coeff. | t Stat. | Coeff. | t Stat. | Coeff. | t Stat. |
| Intercept | 0.63542 | (26.352)* | 0.46734 | (18.252)* | 0.31410 | (12.747)* |
| NCOMP1 | 0.12311 | (1.856)* | 0.08830 | (1.515) | 0.05759 | (1.229) |
| NCOMP2 | -0.06190 | (-3.210)* | -0.05651 | (-3.340)* | -0.04857 | (-3.606)* |
| NCOMP3 | -0.10060 | (-6.609)* | -0.06808 | (-4.971)* | -0.03262 | (-2.944)* |
| NCOMP4 | 0.07906 | (1.469) | 0.03896 | (0.824) | 0.00761 | (0.161) |
| INTER2 | -0.20710 | (-7.929)* | -0.13794 | (-5.752)* | -0.08498 | (-4.138)* |
| INTER3 | -0.17087 | (-6.798)* | -0.09686 | (-4.170)* | -0.03031 | (-1.482) |
| INTER4 | -0.04555 | (-0.990) | -0.01962 | (-0.486) | -0.02412 | (-0.627) |
| AMSDEST | 0.27471 | (3.849)* | 0.23058 | (3.653)* | 0.17978 | (3.834)* |
| ODSIZE | -5.31849 | (-2.221)* | -4.14348 | (-1.970)* | -3.25236 | (-1.939)* |
| ACCESS | 0.00502 | (4.756)* | 0.00504 | (5.238)* | 0.00537 | (6.499)* |
| Adjusted R² | 0.542 | | 0.426 | | 0.400 | |
| Observations | 367 | | 318 | | 274 | |

Numbers without brackets are estimated coefficients, while numbers in brackets are the t-statistic of such estimated coefficients

* Indicates that the estimated coefficient is statistically significant with a 95% confidence.

The results from the model applied to the entire sample of OD markets are given in the first two columns of Table 3.3, under the label “All markets”. However, because

markets with small levels of traffic reflect high variability in the market share, two additional estimations were carried out. In the first one, the sample of observations considered for the OLS estimation was limited to those market-years with annual traffic greater than 50 passengers. In the second one, the sample was limited to those market-years with annual traffic greater than 100 passengers. The results of these two additional estimations are presented in Table 3.3 under the labels “Traffic>50pax” and “Traffic>100pax”, respectively.

In the three estimations carried out similar results are found. *NCOMP2*, *NCOMP3*, *INTER2*, *INTER3*, and *ACCESS* are the five most significant variables. The estimates indicate a higher importance of *NCOMP3* over *NCOMP2*, a result that was not expected. However, as the sample is filtered and only markets with reasonable levels of traffic are analyzed, *NCOMP2* gains a higher weight. From the results of the latter regression it can be interpreted that, on average, an additional competitor carrying passengers through two-leg itineraries produces a decrease of the alliance link market share of approximately 5%, while an additional competitor carrying passengers through three-leg itineraries produces a decrease of 3%, all else equal. In addition, the presence of two-leg interlining routes implies a decrease of 8.5% in market share.

As the sample is filtered and the size of the markets being analyzed gets larger, accessibility becomes the most significant variable, while the variables regarding the level of competition decrease their significance. In fact, the estimate for *INTER3* becomes insignificant on the third estimation. This is a very important result in support of the main hypothesis of the study that accessibility is a critical factor affecting the alliance success in the gain of market share. Indeed, the level of accessibility provided by the alliance link has proven to be key for the alliance increase of market share.

All of the variables present a negative effect on market share except for *ACCESS* and *AMSDEST*. This is a logical result, since it would be expected to have for the alliance a higher-than-average market share on the markets that have Amsterdam as the final destination (*AMSDEST* = 1). In fact, the regression estimates indicate an average of 27%, 23% or 18% higher market share depending on the sample used.

The variable *ODSIZE* presents a negative effect, as it would be expected after evaluating the results obtained in Section 3.4 (see Figure 3.6). An interesting result is that the sign of the coefficient of *NCOMPI* comes out to be positive. This result was unexpected; however, it can be assumed that, whenever *NCOMPI* was different from zero in an O&D market, it was due to the operation of irregular non-stop flights by some carrier on the market for short periods of time during the year². Consequently, the traffic volume carried on such non-stop competing itineraries is extremely small and does not have a significant impact on the overall market share of the alliance link. In fact, the effect of this variable should not be significant, as it happens with the estimates from the samples of markets with traffic greater than 50 and 100 passengers.

One option to analyze the relative importance of each variable on the overall equation that explains the level of market share on every O&D market is to look at the estimated coefficients and the means of every explanatory variable. By multiplying the estimated coefficient obtained through OLS by the mean of the variable, we can estimate the average weight of each variable in the value of the market share achieved by the alliance link. Table 3.4 present the results obtained for the sample with O&D market-years with more than 100 passengers of traffic.

Table 3.4. Relative importance of each variable (markets with traffic > 100 pax)

| Variable | Coeff | μ | $\mu * \text{Coeff}$ |
|---------------|----------|----------|----------------------|
| NCOMP2 | -0.04857 | 1.03650 | -5.03% |
| NCOMP3 | -0.03262 | 1.33942 | -4.37% |
| INTER2 | -0.08498 | 0.59489 | -5.06% |
| INTER3 | -0.03031 | 0.58394 | -1.77% |
| ACCESS | 0.00537 | 16.50483 | 8.86% |

In the above table, only the variables that are useful to be compared have been included. The results obtained indicate that the accessibility provided by the alliance link contributes to the market share of the alliance on average by 8.86%. This

² This assumption is based on the fact that there were no scheduled non-stop flights out of the three airports considered in the analysis, for any of the O&D markets considered. In addition, the data reveals a small level of traffic carried through non-stop itineraries whenever they exist, which supports the claim of the non-stop flights being operated for short periods of time.

contribution is higher in absolute value than any of the average negative contributions from the other 4 variables. In other words, the results of table 3.6 reveal that the accessibility is the variable among all the variables considered in the model with the highest contribution to the market share achieved by the alliance.

Cross-Tabulation Exercise

The results obtained from the OLS estimation demonstrate that there is a clear correlation between the increase in market share and the degree of accessibility provided by the alliance hub-to-hub link. However, this correlation does not imply causality. To support a causal relationship between market share and accessibility, a cross-tabulation exercise was carried out. Changes in accessibility experienced in consecutive years for some markets were plotted versus the changes experienced in market share in the same markets. Figure 3.20 shows the results.

The set of observations used to do the cross-tabulation exercise were those O&D markets among the entire sample in which Northwest and/or KLM carried traffic in close or consecutive years. Because there were many isolated markets—that is, markets on which NW/KL only carried passengers in 1997, for example—and because the O&D market-years of the regression analysis had to be grouped into pairs in order to form observations to do the cross-tabulation, only 142 pairs of observations were selected out of the total 367 observations. Table 3.5 shows the sample used for the cross-tabulation exercise. Most of the data points were formed from observations on the years 1996 and 1997, and 1995 and 1996.

In the table, “X” indicates that the levels of accessibility and traffic on the O&D market at the left of the row and in the pair of years at the top of the column were used to form a data point for the cross-tabulation exercise. Percentage changes on accessibility and market share were estimated for every data point.

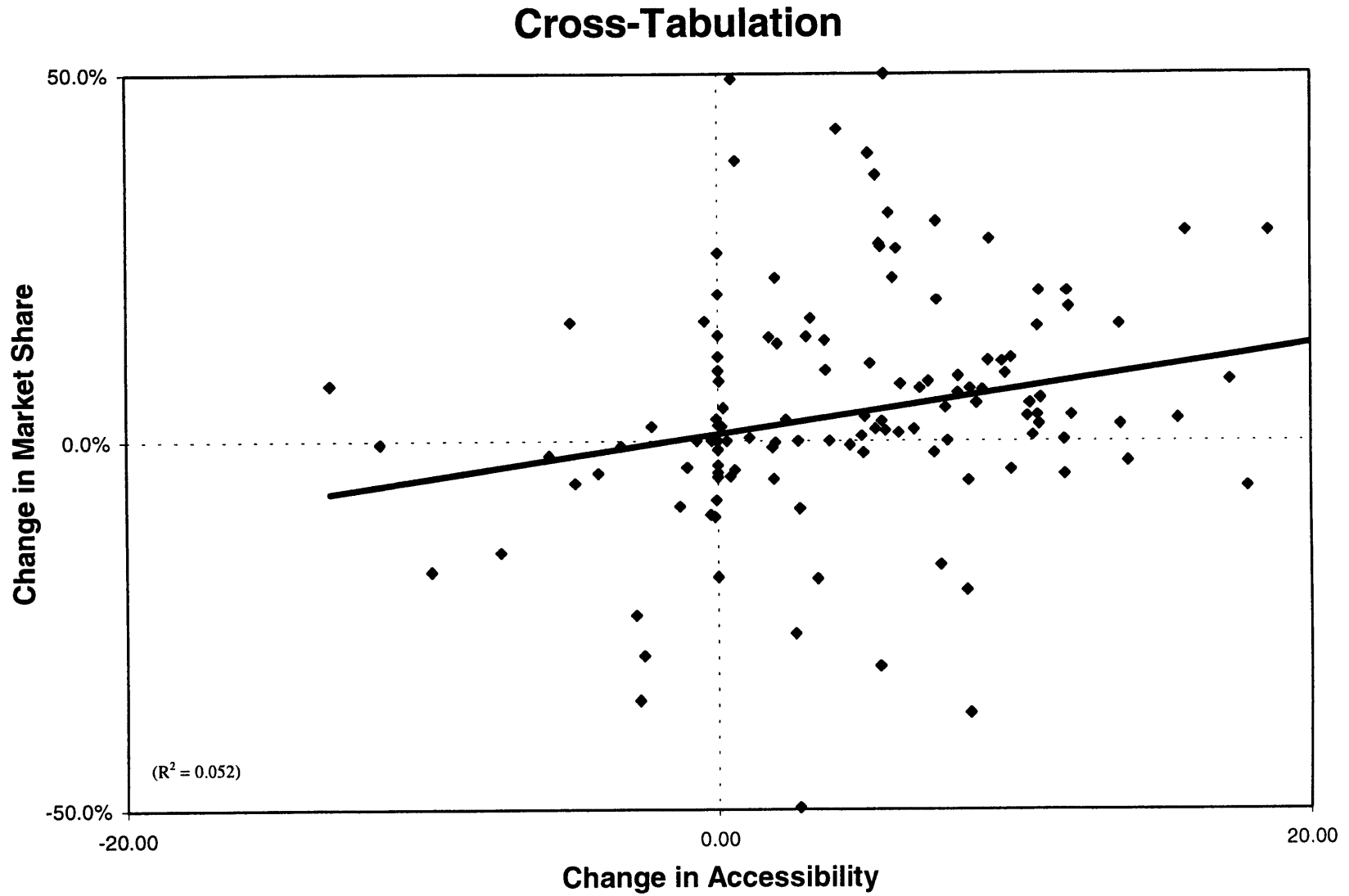

Figure 3.20. Cross-Tabulation of changes in accessibility versus changes in market share

Table 3.5. O&D markets used for the cross-tabulation exercise

| O&D Market | 90-91 | 91-92 | 92-93 | 93-94 | 93-95 | 93-96 | 93-97 | 94-95 | 94-96 | 94-97 | 95-96 | 95-97 | 96-97 | Total |
|------------|-------|-------|-------|-------|-------|-------|-------|-------|-------|-------|-------|-------|-------|-------|
| BNA-ACC | - | - | - | - | - | - | - | - | - | - | - | X | - | 1 |
| BNA-AMS | X | X | X | X | - | - | - | X | - | - | X | - | X | 7 |
| BNA-BUD | - | - | - | - | - | - | - | - | - | - | X | - | X | 2 |
| BNA-CPH | - | - | - | - | - | - | - | - | - | - | X | - | X | 2 |
| BNA-DHA | - | - | - | - | - | - | - | - | - | - | - | - | X | 1 |
| BNA-FBU | - | - | - | - | - | - | - | - | - | X | - | - | - | 1 |
| BNA-FCO | - | - | - | - | - | - | - | - | - | - | X | - | X | 2 |
| BNA-GVA | - | - | - | - | - | - | - | - | - | - | X | - | X | 2 |
| BNA-HAM | - | - | - | - | - | - | - | - | - | - | - | - | X | 1 |
| BNA-JNB | - | - | - | - | - | - | - | - | - | - | - | X | - | 1 |
| BNA-KBP | - | - | - | - | - | - | - | - | - | - | - | - | X | 1 |
| BNA-LOS | - | - | - | - | - | - | - | - | - | - | X | - | X | 2 |
| BNA-MUC | - | - | - | - | - | - | - | X | - | - | X | - | X | 3 |
| BNA-NUE | - | - | - | - | X | - | - | - | - | - | - | - | - | 1 |
| BNA-STR | - | - | - | - | - | - | - | - | - | - | - | - | X | 1 |
| BNA-SVO | - | - | - | - | X | - | - | - | - | - | X | - | X | 3 |
| BNA-TLV | - | - | - | - | - | - | - | - | - | - | X | - | X | 2 |
| BNA-TXL | - | - | - | - | - | - | - | - | - | - | X | - | X | 2 |
| BNA-VCE | - | - | - | - | - | - | - | - | - | - | X | - | X | 2 |
| BNA-VIE | - | - | - | - | - | - | - | X | - | - | X | - | X | 3 |
| BNA-WAW | - | - | - | - | - | - | - | - | - | - | - | X | - | 1 |
| BNA-ZRH | - | - | - | - | - | - | - | - | - | - | X | - | X | 2 |
| MCI-AMM | - | - | - | - | - | - | - | - | - | - | X | - | X | 2 |
| MCI-AMS | X | X | X | X | - | - | - | X | - | - | X | - | X | 7 |
| MCI-ARN | - | - | - | - | - | - | - | - | - | - | X | - | X | 2 |
| MCI-BCN | - | - | - | - | - | - | - | - | - | - | - | - | X | 1 |
| MCI-BRU | - | - | - | - | - | - | - | - | - | - | X | - | - | 1 |
| MCI-CAI | - | - | - | - | - | - | - | - | - | - | - | X | - | 1 |
| MCI-CPH | - | - | - | X | - | - | - | X | - | - | X | - | X | 4 |
| MCI-DAM | - | - | - | - | - | - | - | - | X | - | - | - | X | 2 |
| MCI-DUS | - | - | - | - | - | - | - | - | - | - | X | - | - | 1 |
| MCI-FBU | - | - | - | - | - | - | X | - | - | - | - | - | - | 1 |
| MCI-FCO | - | - | - | - | - | - | - | X | - | - | X | - | X | 3 |
| MCI-HAM | - | - | - | X | - | - | - | X | - | - | X | - | X | 4 |
| MCI-LUX | - | - | - | - | - | - | - | - | - | - | - | - | X | 1 |
| MCI-NUE | - | - | - | - | - | - | - | X | - | - | - | X | - | 2 |
| MCI-SVG | - | - | - | - | - | - | - | - | X | - | - | - | - | 1 |
| MCI-SVO | - | - | - | X | - | - | - | X | - | - | X | - | X | 4 |
| MCI-THR | - | - | - | - | - | - | - | - | - | - | - | - | X | 1 |
| MCI-TXL | - | - | - | - | - | - | - | X | - | - | X | - | X | 3 |
| MCI-VIE | - | - | - | - | X | - | - | - | - | - | X | - | X | 3 |
| MCI-WAW | - | - | - | - | - | - | - | - | - | - | - | - | X | 1 |
| MCI-ZRH | - | - | - | - | - | - | - | - | - | X | - | - | - | 1 |
| STL-AMS | X | X | X | X | - | - | - | X | - | - | X | - | X | 7 |
| STL-ARN | - | - | - | - | - | - | - | - | X | - | - | - | X | 2 |
| STL-ATH | - | - | - | - | - | - | - | - | - | - | - | - | X | 1 |
| STL-AUH | - | - | - | - | - | - | X | - | - | - | - | - | - | 1 |
| STL-BAH | - | - | - | - | - | X | - | - | - | - | - | - | - | 1 |
| STL-BUD | - | - | - | - | - | - | - | - | - | - | X | - | X | 2 |
| STL-CAI | - | - | - | - | - | - | - | - | - | - | X | - | X | 2 |
| STL-CPH | - | - | - | - | - | - | - | X | - | - | X | - | X | 3 |
| STL-DXB | - | - | - | X | - | - | - | X | - | - | X | - | X | 4 |
| STL-FCO | - | - | - | - | - | - | - | - | - | - | X | - | X | 2 |
| STL-HAJ | - | - | - | - | X | - | - | - | - | - | X | - | X | 3 |
| STL-HEL | - | - | - | - | - | - | - | - | - | - | X | - | X | 2 |
| STL-JNB | - | - | - | - | - | - | - | - | - | - | X | - | - | 1 |
| STL-JRO | - | - | - | - | - | - | - | - | - | - | X | - | X | 2 |
| STL-LOS | - | - | - | - | - | - | - | - | - | - | - | - | X | 1 |
| STL-MAD | - | - | - | - | - | - | - | - | - | - | X | - | X | 2 |
| STL-MUC | - | - | - | - | - | - | - | X | - | - | X | - | X | 3 |
| STL-NBO | - | - | - | - | - | - | - | - | - | - | - | - | X | 1 |
| STL-NCE | - | - | - | - | - | - | - | - | X | - | - | - | - | 1 |
| STL-OTP | - | - | - | - | - | - | - | - | - | - | - | - | X | 1 |
| STL-PAD | - | - | - | - | - | - | - | - | - | - | - | - | X | 1 |
| STL-PRG | - | - | - | - | - | - | - | X | - | - | X | - | X | 3 |
| STL-VIE | - | - | - | X | - | - | - | X | - | - | X | - | X | 4 |
| STL-ZRH | - | - | - | - | - | - | - | X | - | - | X | - | X | 3 |
| Total | 3 | 3 | 3 | 8 | 4 | 1 | 2 | 17 | 4 | 2 | 39 | 5 | 51 | 142 |

If there were a causal relationship between accessibility and market share, when accessibility increases from one year to the next year, the market share would be expected to increase as well. And when accessibility decreases, the market share would be expected to decrease. This implies that in a cross-tabulation plot like the one presented in Figure 3.20, most of the data points should fall within two quadrants: The lower-left quadrant, indicating that decreases in accessibility are followed by decreases in market share, and the upper-right quadrant, indicating that increases in accessibility are followed by increases in market share.

The plot presented in figure 3.20 indicates that, indeed, the majority of the data points fall within the two quadrants. In fact a least-squares trend-line superposed to the data points shows a positive slope. As expected, there is a great disparity among the data points, which are widely scattered over the diagram. As discussed earlier, accessibility is not the only factor affecting the market share, and the changes in accessibility experienced by one O&D market cannot explain by itself the changes in market share. Consequently, the goodness of fit of the trend-line (0.052) is very low. However, the significant correlation between accessibility and market share found in the regression analysis and the positive slope of the trend-line found in the cross-tabulation exercise support a causal relationship between the two variables.

3.6.3. Accessibility versus Frequency

In order to compare the effect on market share of the frequency of service offered through the hub to hub link with the effect of accessibility, accessibility was substituted with frequency in the data sample and OLS was applied again. The definition of frequency for O&D markets connected through multiple legs is not clear. The definition used here is the sum for each hub-to-hub flight of the maximum number of itineraries traversing the hub-to-hub flight that do not repeat connecting flights and that fall within a reasonable time window when connecting at the hubs. Such definition of frequency is equivalent to making cap_i equal to 1 for all i , $f_{OH}(t)$ and $f_{HD}(t)$ equal to 1 for all t that

falls within the connecting time window and 0 otherwise, and $f_s(n)$ equal to 1 for all n , in the accessibility equation.

The results of the OLS estimation carried out for the filtered sample of O&D market-years that had traffic greater than 100 passengers using frequency instead of accessibility are presented in Table 3.6. The figures of the t-statistic shown in the table indicate that the definition of accessibility has a slightly more significant impact on market share than the simpler frequency measure.

Table 3.6. Accessibility versus frequency. Regression results (Traffic>100pax)

| Variable | Accessibility | | Frequency | |
|-------------------------------|---------------|-----------|-----------|-----------|
| | Coeff. | t Stat | Coeff. | t Stat |
| Intercept | 0.31410 | (12.747) | 0.30703 | (11.821) |
| NCOMP1 | 0.05759 | (1.229) | 0.06963 | (1.449) |
| NCOMP2 | -0.04857 | (-3.606) | -0.04992 | (-3.586) |
| NCOMP3 | -0.03262 | (-2.944) | -0.03200 | (-2.671) |
| NCOMP4 | 0.00761 | (0.161) | 0.00282 | (0.073) |
| INTER2 | -0.08498 | (-4.138) | -0.07914 | (-3.734) |
| INTER3 | -0.03031 | (-1.482) | -0.02540 | (-1.240) |
| INTER4 | -0.02412 | (-0.627) | -0.01458 | (-0.406) |
| AMSDEST | 0.17978 | (3.834) | 0.32258 | (6.867) |
| ODSIZE | -3.25236 | (-1.939) | -3.90223 | (-2.265) |
| ACCESS/FREQ | 0.00537 | (6.499) | 0.01922 | (5.142) |
| Adjusted R² | 0.400 | | 0.367 | |

A further analysis to evaluate the relative weight of each variable was also carried out. As in Section 3.6.2, the mean of each variable was used to approximate the relative importance of each variable by multiplying them by the estimated coefficients from the regression. The results are presented in Table 3.7.

Table 3.7. Accessibility versus Frequency. Relative importance of each variable

| | Coeff | t Stat | μ | μ * Coeff |
|----------------------|---------|----------|-------|---------------|
| Accessibility | 0.00537 | (6.499) | 16.50 | 8.86% |
| Frequency | 0.01922 | (5.142) | 3.95 | 7.59% |

The above tables indicate a higher contribution to the market share of accessibility than frequency. On average, accessibility contributes to the market share with 8.86%, while frequency only with 7.59%. Ideally, both variables should be added to the regression equation and then the estimated coefficients and t-statistics compared; however, because accessibility and the definition used for frequency are two variables highly correlated, when they are incorporated to the regression equation and OLS is run, they produce multicollinearity. Consequently, they become non-significant variables and cannot be compared in this way.

3.6.4. Sensitivity Analysis

In the definition of accessibility given in Section 3.5, the time interval Δt represents the time window where the convenience of the connecting flights is highest (see figure 3.8). The determination of this time window should be particularly important for management, since the connecting flights that fall within it will provide higher accessibility—all else equal—to the hub-to-hub link, and consequently, will have a greater impact on the market share. In other words, ideally, the airline would want to schedule the most number of connecting flights within this time window in order to have the greatest impact on the hub-to-hub connectivity and consequently on the alliance hub-to-hub markets share³.

The critical parameter that defines the time location of the interval Δt is the parameter t_{opt} , which represents the optimal connecting time from a passenger's convenience point of view. The value of t_{opt} —and consequently the location of Δt —is subjective, and was estimated based on logical assumptions in Section 3.5. Therefore, in this section, we carry out a sensitivity analysis in order to determine which are the critical values of t_{opt} —and consequently the critical locations of Δt —that have the greatest impact on market share.

³ Of course, in a more realistic scheduling decision framework, there are many other additional considerations to take into account besides the hub-to-hub connectivity. Here, as an academic exercise, the focus of the discussion is on the hub-to-hub implications alone.

The sensitivity analysis was performed running OLS over the sample of O&D market-years using different values of the parameter t_{opt} , and leaving fixed the values of t_{min} , t_{max} , and Δt . To make more effective the sensitivity analysis, the value of Δt was reduced to 1 hour (it was 1:30 hours previously) and centered around t_{opt} . Therefore, in all cases t_1 was given by $(t_{opt} - 30 \text{ min.})$ and t_2 by $(t_{opt} + 30 \text{ min.})$. t_{opt} was varied in increments of 30 min. Figure 3.21 shows the different connecting convenience functions used for every value of t_{opt} .

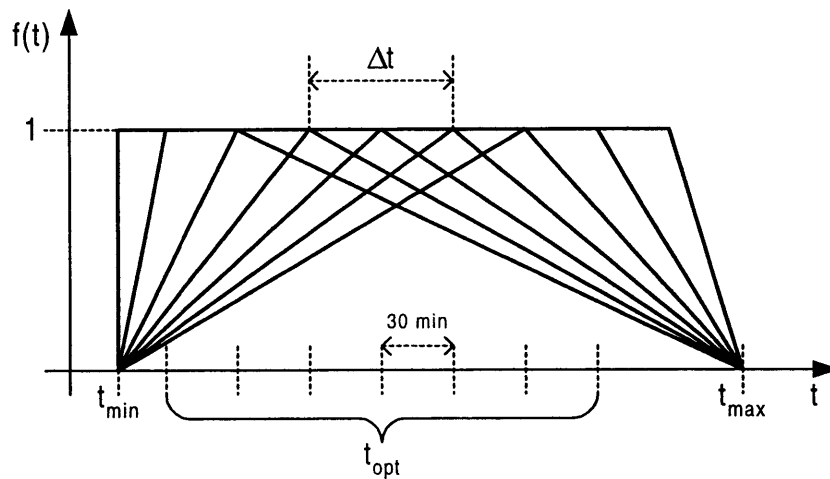

Figure 3.21. Different connecting convenience functions used for the sensitivity analysis

The sample of O&D market-years used to run the OLS estimations consisted of observations with traffic greater than 100 passengers, since the errors introduced are smaller. The results obtained for each value of t_{opt} , and consequently, for each shape of the connecting convenience function are presented in the table below.

Table 3.8. Regression results for different values of t_{opt}

| t_{opt} (hrs:min) | Coeff | t Stat | μ | μ *Coeff |
|---------------------|---------|----------|-------|--------------|
| 1:00 | 0.00569 | (6.164) | 13.70 | 7.80% |
| 1:30 | 0.00565 | (6.411) | 14.56 | 8.22% |
| 2:00 | 0.00621 | (6.253) | 13.16 | 8.17% |
| 2:30 | 0.00655 | (6.712) | 13.50 | 8.84% |
| 3:00 | 0.00708 | (6.651) | 11.78 | 8.34% |
| 3:30 | 0.00724 | (6.879) | 11.92 | 8.62% |
| 4:00 | 0.00729 | (6.565) | 10.76 | 7.84% |

Plotting in a chart the results shown in the above table gives the curve presented in Figure 3.22. A polynomial trend-line has been superposed to the data points in order to approximate the impact of the different locations of Δt on the market share. The results obtained were expected. As t_{opt} gets closer to the minimum and maximum connecting times, the impact of accessibility on market share becomes smaller, existing an intermediate value of t_{opt} where the impact is greatest. We can interpretate from the results presented in Table 3.8 to come up with an important conclusion regarding the scheduling of connecting flights. Such conclusion is that lights scheduled close to the minimum connecting time or scheduled far away from the arrival/departure of the hub-to-hub flight contribute in a lesser amount to the alliance connectivity through the hub-to-hub link. There seems to be a range of times to schedule connecting flights that go from 1:30 hours to 3:30 hours between the departure/arrival of the hub-to-hub flight and the arrival/departure of the connecting flight where the impact of the hub-to-hub connectivity has the greatest impact on demand.

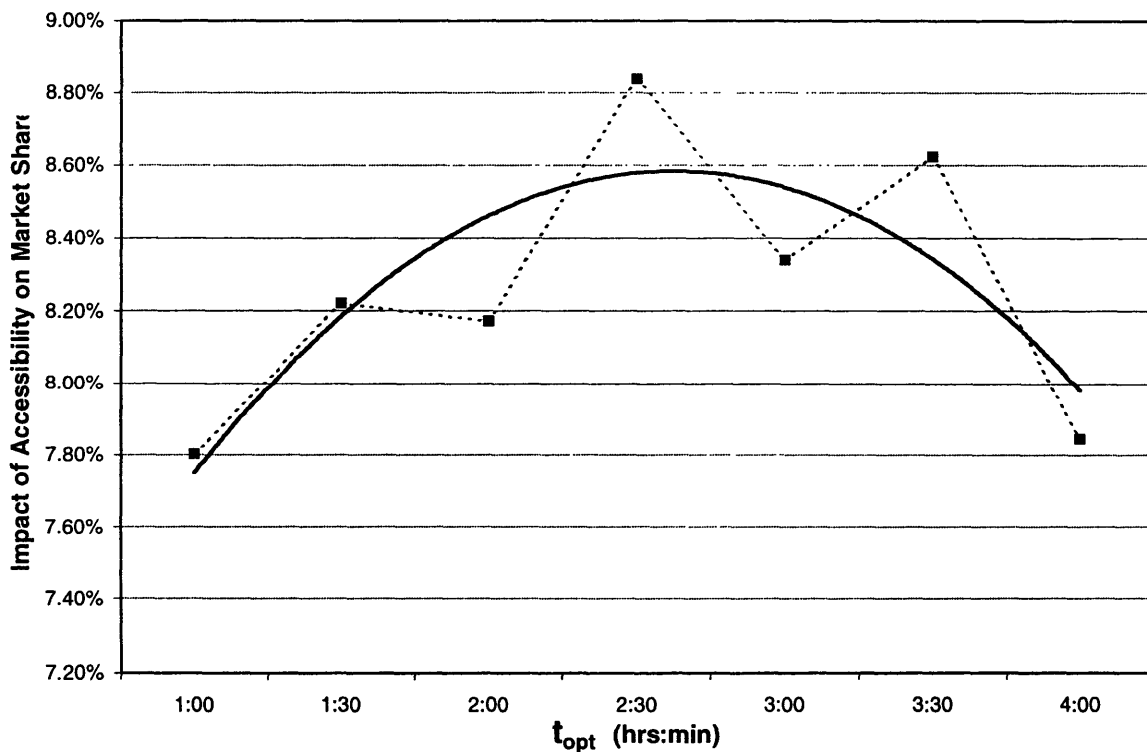

Figure 3.22. Impact of accessibility on market share as a function of t_{opt}

3.7. Discussion of Main Assumptions

Several assumptions concerning the definition of accessibility and its impact on market share have been used in the analysis carried out in this chapter. Below, the main assumptions that are present on the analysis are highlighted. Their implications and limitations on the validity of the results obtained are discussed.

First, in the regression model developed, accessibility is the only level-of-service variable being included. In any transportation analysis is a common practice to include several LOS variables as explanatory variables, such as the travel time, the fares, or the quality of passenger service. However, in practice, there are multiple constraints that limit the incorporation of these variables into the model, and their incorporation might bring little value to the analysis. The *travel time* is difficult to estimate for a given O&D market, since different itineraries take different times. In addition, the travel time should not be an important factor for transatlantic markets. Following the same reasoning, neither the influence of *circuitry* has been included. The author's belief is that other variables such as the time of day of the arrival and departure would have a greater influence on demand. However, as discussed in Section 3.8, their incorporation into a more complex model and the evaluation of their impact on accessibility and demand should be carried out in further research studies.

Airfares are very important variables driving demand. However, it is difficult to come up with a measure of an average airfare offered by the alliance on each O&D market. Most airlines today match fare levels so that all of them offer similar prices for each fare-class. Hence, if published fares were taken in the model they would have a small impact on the market share. In addition, the actual airfares offered to customers do not depend so much on the published fares as they do on the seat availability for each fare-class offered by carriers. Here, it is faced the problem that for the same O&D market, different itineraries present different availabilities and consequently, different average fares actually paid by passengers. This fact complicates the estimation of an average fare for each O&D market-year in the sample.

An average fare for each O&D market could be computed by weighting the average fare paid on each itinerary by their traffic levels. However, the author's belief is that such average fare would be more a consequence of capacity management than price management itself. Thus, because the measure of accessibility developed incorporates capacity—and therefore, accessibility should be related the level of fares, as discussed in Section 3.5—the impact of airfares on market share should be reflected to some extent in the level of accessibility provided by the alliance. Nevertheless, it should be interesting to carry out a further analysis in order to evaluate both the impact of accessibility and fares on market share and the correlation between accessibility and the average fares paid on each O&D.

To estimate a LOS variable related to the *quality of passenger service* is difficult, since is a “soft” variable and there is little information about it. In addition, the alliance must offer similar passenger service to all O&D markets served through the hub-to-hub link. Thus, it should not have a significant impact on the market share. The relative differences between the quality of service offered by the alliance and the quality of service offered by competitors, however, are expected to have an impact. Because there are multiple competing itineraries in each O&D market and the quality of service is a “soft” variable, it would be extremely difficult to come up with a measure of the relative difference between the alliance quality of service and the competitor's quality of service. In addition, because most transatlantic carriers offer similar passenger service, it should have relatively little impact on demand.

Second, the regression model developed does not take into account the LOS variables of itineraries offered by competitors. For example, it is concluded that accessibility is a key variable affecting market share, but it has not been included into the model the level of accessibility provided by competing itineraries. These variables would indeed affect significantly the market share achieved by the alliance link in each O&D market. However, as has been discussed above, each O&D market presents different competing itineraries. Consequently, it would be extremely difficult to come up with a measure of competitor's LOS variables in each O&D market-year observation.

In fact, because multiple LOS variables from both the alliance and the competing carriers as well as other variables affecting demand—like variables regarding sales and travel-agent arrangements—were not considered in the equation, the regression model is only able to explain 40%-50% of the changes experienced by the alliance market share. Nevertheless, the results obtained are enough to provide us with information about the impact that the alliance network connectivity has on the alliance success in increasing its market share.

Third, the definition of accessibility provided in Section 3.5 is based on arbitrary functions that have been selected based on reasonable assumptions. The functions selected should reflect in the author's opinion the utility of the connecting itineraries for passengers. However, it would be interesting to carry out further sensitivity analyses with different functions in order to evaluate which of them reflect more precisely the passenger utility.

Fourth, the measure of accessibility used to explain the level of alliance connectivity developed in Section 3.5 does not incorporate the effect of connecting domestic itineraries—that is, domestic connections that consist of itineraries of more than one flight leg. The data of the analysis shows that, in fact, there was some traffic that flew through domestic itineraries of this sort before/after taking the transatlantic hub-to-hub flight. However, those levels of traffic were small, and the author's belief is that the contribution of those itineraries to the overall O&D accessibility can be ignored.

Finally, the OLS estimation in the analysis was run over a sample of O&D market-years that considered small and large markets with the same weight. However, small markets can provide high variability to the market share—a small market where NW/KL carried the only 10 passengers that flew on the market will show a 100% market share. To avoid this problem, the sample of observations was filtered and was limited to those market-years that had reasonable levels of traffic (over 50 and 100 passengers). Still, no consideration on the higher revenue value of larger markets for the alliance was made in the model.

In addition, only those market-years were NW/KL carried passengers (market share greater than zero) were considered in the sample. This fact could distort the results concerning the correlation between market share and accessibility—since multiple markets with null market share and probably different-from-zero accessibility were not included. To support the causal relationship between market share and accessibility inferred by the regression results, the cross-tabulation exercise of section 3.6.2 was carried out.

3.8. Conclusions

The alliance hub-to-hub scheme has proven to be very effective in increasing the market share of the alliance when the networks of the two partner airlines are linked. Service to additional O&D markets is offered to customers, some of who decide to shift carriers and fly through the alliance hub-to-hub link instead of through competing itineraries. In the three US airports studied, the alliance hub-to-hub link has shown a continuous increase in market share, while the rest of alliance transatlantic flights have shown a decrease or sustenance. Consequently, the alliance hub-to-hub link and its level of network connectivity has supposed for the NW/KL alliance a significant source of additional traffic—and therefore revenue—and has constituted the main element in the alliance's ability to increase its market share in the transatlantic markets.

At an O&D level, the alliance's ability to capture market share has proven to be more effective over small markets (little traffic), where the level of competition is low. However, the markets that have provided to the alliance the highest levels of traffic—and therefore revenue—are in the medium-large range of sizes.

Accessibility has been developed as a measure of the alliance connectivity provided through the hub-to-hub link, and incorporates the effect of several level-of-service variables, such as the connecting convenience at the hubs, the frequency, or the number of stops. Because seat-capacity is included in its definition, the measure of accessibility

is also related to the availability of low fares, and therefore, to the average fare paid by customers.

The regression model developed has shown that accessibility is a key variable to determine the market share achieved by the alliance hub-to-hub link in each O&D market. In fact, when the sample of observations is restricted to O&D market-years with reasonable levels of traffic, it becomes the most significant variable and the variable that has the greatest average contribution to the market share among all the explanatory variables considered in the model. In addition, the results from the analysis have shown that the measure of accessibility has a greater effect on the alliance market share than frequency.

The sensitivity analysis has revealed that connecting flights scheduled close to the minimum connecting time as well as connecting flights scheduled far away from the departure/arrival of the hub-to-hub flight have a smaller impact on demand than the flights scheduled in-between. There is an intermediate time window in which the connecting flights should have the greatest impact on demand.

In conclusion, the management of accessibility represents a key factor for alliances and their goal to increase their traffic shares on the markets linked by their hub-to-hub flights. Therefore, scheduling coordination and capacity management within airline alliances should focus on providing high levels of accessibility through the alliance hub-to-hub links. As a result, the alliance market share should increase. There are two basic ways in which airline alliances can achieve high levels of accessibility.

First, through the addition of capacity on the hub-to-hub links or the connecting routes. This is the most expensive option and economic evaluations should also be performed to make a final decision. However, this option should also be the most effective alternative to increase market share. On the one hand, the addition of more flights increases frequency. On the other hand, the addition of more seats increases availability, and therefore, decreases the average fare paid by customers. Both frequency and availability of low-fare classes are two key drivers of demand.

Second, through the adjustment of schedules of connecting flights, so that the connecting convenience—and therefore the accessibility—is increased. That is, by adjusting schedules so that the departure/arrival of connecting flights falls within the parameter Δt given in the definition of accessibility. It is difficult to know what the “optimal” time window Δt to schedule connecting flights is, since, in the definition of accessibility, the value and location of Δt has been arbitrarily determined based on logical assumptions. However, the results of the sensitivity analysis have indicated that connecting flights scheduled within 1:30 and 3:30 hours from/to the hub-to-hub flight arrival/departure should have the greatest impact on demand. Although these results must be cautiously evaluated, they can be taken as a reference for scheduling planning.

The model developed in this chapter does not take into account the effect of other additional variables, such as airfares, quality of passenger service, or the LOS offered by competing carriers. However, this chapter has provided the basis of a framework that explains network connectivity as a main driver of demand. Further research should incorporate into the model the effect of additional variables, and evaluate their impact.

Chapter 4

Impacts of Codesharing for Revenue Management

4.1. Introduction

The Revenue Management System (RMS) of an airline is the system used to maximize revenue given the schedule and the forecast of air traffic demand for the airline's network. As we enter the twenty-first century, the practice of revenue management has become a critical element for airline profitability. In the words of Thomas Cook¹, "the yield management system of American Airlines generated almost \$1 billion in annual incremental revenue in 1997, while overall operating earnings had only reached that level for the first time in history in 1997". Other studies have shown revenue gains from the use of revenue management tools of 2 to 6% (Smith et al., 1992, and Belobaba, 1987).

Airline alliances have an impact on RMSs by introducing codeshare flights into the partners' networks. As discussed in Chapter 1, codesharing is the device used by alliance partners to increase network size without additional investments in aircraft. The practice of codesharing introduces in the airline's RMS new types of flights and classes that increase the complexity of the booking control process. Before codesharing was introduced, RMSs had to deal with just one type of flight. Once codesharing has been introduced, RMSs must deal with three types: Normal flights, partner-operated codeshare flights (airline-code* flights), and airline-operated codeshare flights (partner-code* flights). The distinction among them is further explained in Section 4.3.

¹ Thomas Cook was Senior Vice President of SABRE Technology Solutions. Refer to "Sabre Soars", *ORMS Today*, June 1998, pp. 26-31.

Because the practice of revenue management is key for airline profitability, a chief assignment for airline management within the context of airline alliances is to adapt the RMSs of their airlines to the new alliance scenario, so that all the issues brought by codesharing are overcome. Traditionally, codeshare traffic has been a small portion of an airline's overall traffic, and all the issues discussed in this chapter did not result of critical importance for the airlines involved in alliances. However, the continuous increase in the number of alliances experienced by the airline industry in the last decade suggests that codeshare traffic could become a significant portion of an airline's overall traffic.

The author's belief is that the handling of codesharing by RMSs today has become a critical issue for airline management, a critical issue whose modeling approaches may have a significant impact on revenues. As we enter the twenty-first century and alliances are consolidated as critical elements of the airline industry, the handling of codesharing will become even more important. This is the motivation behind this chapter, a chapter intended to bring some light to an area that, so far, has remained diffuse.

In the chapter, the spectrum of problems faced by RMSs when codeshare flights are introduced in an airline's network is presented. The goal of the chapter is to illustrate the different issues arising from the way different revenue management approaches handle codeshare traffic. First, in Section 4.2, different dimensions to look at the problems brought by codesharing to revenue management are presented. Then, in Section 4.3, a review of revenue management is provided, and in Section 4.4, the different aspects of codesharing from a revenue management point of view are introduced. Section 4.5 explores the main approaches used to handle codesharing within RMSs. Some are current approaches taken in the industry, while others reflect just potential alternatives. Finally, in Section 4.6, an overview of the different issues brought by codesharing in each of the RMS approaches described earlier in Section 4.5 is presented. In addition and as an initial step for future research, potential modeling solutions are proposed.

The discussion throughout the chapter is based on two different revenue management methods: Conventional revenue management, which maximizes revenues on a leg basis, and more sophisticated O&D revenue management, which maximizes revenues on a network basis.

Due to the lack of published information and previous research in the field, most of the information and technical details included in the chapter come from direct conversations held with professionals working in or related to the field, and from the author's own experience.

4.2. Problems and Dimensions of Codesharing for Revenue Management

The full impacts of codesharing for RMSs can be analyzed at two different levels. On the one hand, at a contractual level, the economic terms of codesharing agreements must be specified. That is, revenue sharing methods and seat-availability procedures must be established for codeshare traffic among alliance partners. On the other hand, at an operational level, once the economic terms of codesharing agreements have been settled, RMSs and Computer reservation systems (CRSs) must be able to recognize codeshare traffic and treat it accordingly to such contractual terms. Figure 4.1 summarizes the different impacts of codesharing for revenue management at their different dimensions.

At the contractual level, methods and terms for revenue sharing and seat allocation must be specified first. The implications of the different alternatives are diffuse, and often airlines base their points of view for the elaboration of the agreements on somewhat "arbitrary" criteria. Indeed, the task of developing methods and terms for revenue sharing and seat allocation constitutes, in essence, the "endless" problem of *transfer pricing* (see Eccles, 1983). A problem faced—in many cases unsolved—by numerous companies worldwide, as well as researchers in the area of Management Science. Therefore, a subsequent task once the methods and terms of a codesharing

agreement have been established is a continuous monitoring of the agreement and its impacts on the airline profitability. Potential sources of economic conflict as well as potential sources of improvement should be identified for the furtherance of the partnership.

The practice of codesharing requires that methods and terms for revenue sharing and inventory control be established among alliance partners. Hence, any airline involved in a codesharing alliance must have faced and solved the first problem: The establishment of the economic terms of the codesharing agreement. However, few airlines today undergo the second problem: The monitoring of agreements and their economic impacts. Although most airlines highlight revenue gains associated with certain codesharing practices, few of them are able in practice to isolate the true incremental profit achieved through the codesharing alliance, and compare different alternatives in the treatment of codeshare traffic. This is fundamentally due to the lack of appropriate metrics that allow the measurement of the real benefits brought by the codesharing partnership to the alliance members.

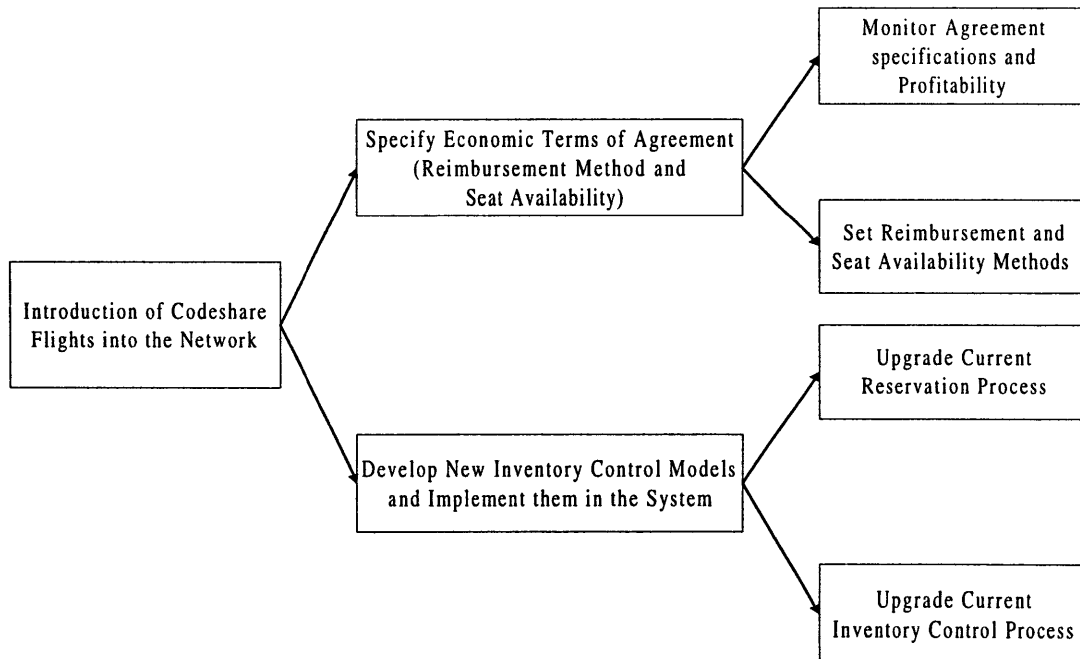

Figure 4.1. Problems and dimensions of codesharing for revenue management

At the operational level, there are again two different problems to be faced by revenue management. First, models that account for codeshare traffic and allocate seats accordingly to the economic terms of the agreement must be developed. Second, CRSs must be adapted to the new codesharing scenario in order to manage such models in the day-to-day booking control process. The first problem is related to the RMS, while the second is related to the CRS.

The mere introduction of codeshare flights into CRSs is not a significant problem. The common practice is to introduce additional flight numbers into the system, so that the flight number of each flight identifies the carrier operating it. If airline X operates less than 1000 flights and decides to assign a number greater than 1000 to any codeshare flight operated by a partner, the flight XX 1545, for example, even though has the designator code of airline X, would be a codeshare flight operated by another carrier. If the models for seat allocation of codeshare traffic are simple, the treatment of codeshare traffic by CRSs will be similar—if not the same—as that of normal traffic. The type of codesharing agreement has a critical impact on the complexity of the seat-allocation models, and therefore on the complexity of the booking control process for codeshare traffic. For example, *block space* agreements (described in Section 4.4) imply in general lower complexity than *free sale* agreements from a CRS point of view.

The introduction of codeshare flights into the RMS is a more critical issue. Airlines must decide how they should value codeshare traffic and then do seat inventory control accordingly. In general, there is no uniform criterion in this respect. Typically, airlines have treated passengers flying on codeshare flights the same way as they have normal passengers. This approach minimizes operational problems and does not require substantial changes on current systems. However, this approach presents several shortcomings, the discussion of which constitutes the body of this chapter.

In this section, four different problems faced by revenue management when dealing with codesharing have been presented. These are grouped at two levels: A contractual level and an operational level. The four problems are strongly interrelated in practice, and the issues concerning any of them depend on the issues concerning the others.

However, for academic purposes, the four problems can be isolated and studied separately. This chapter focuses particularly on the valuation and allocation of seats for codeshare traffic.

In general, when airlines face the need to adapt their RMSs to incorporate codesharing, some change their systems in order to value codeshare traffic accordingly with the economic terms of the codesharing agreement, while others hardly change their systems and treat codeshare traffic the same way as ordinary traffic. Ideally, RMSs should identify contractual conditions from the codesharing agreements and do inventory control on codeshare legs based on such conditions. However, this increases the complexity of the RMS significantly, and may also go against the philosophy behind strategic alliances, which pursues to offer a seamless service to all customers throughout the entire network independently of the carrier operating the flights.

4.3. Review of Revenue Management

The revenue management system of an airline is in charge of managing passenger requests in order to maximize revenue, and is often described as the system able to sell “the right seats to the right customers at the right price.”² It basically consists of splitting the demand for air travel in different classes, setting prices for every class, setting overbooking limits, and controlling the number of seats available to each class in order to maximize revenues. Belobaba (1998) describes the premise behind airline yield management as follows:

“Make seats that are expected to go unsold available at a lower fare to passengers who will otherwise not travel, while at the same time ensuring that these lower fares are not purchased by passengers who are willing to pay a higher fare.”

² This quote is commonly attributed to Crandall, former Chairman and CEO of AMR Corporation. The quote can be found in the 1987 annual report of American Airlines, where it is used to describe the basic goal of revenue management.

Airline revenue management has two separate components: *pricing* and *seat inventory control*. Both practices are performed repeatedly for each flight during a specific period (limited to 1 year) prior to the departure date. Pricing consists of offering a diversity of fare products, often called fare classes, differentiated in terms of service amenities and/or travel restrictions, and assigning a price to each one. Seat inventory control is often called yield management and is performed by the RMS of the airline. It consists of determining the number of seats that must be made available for each fare class based on the forecast of demand, in order to maximize revenue.

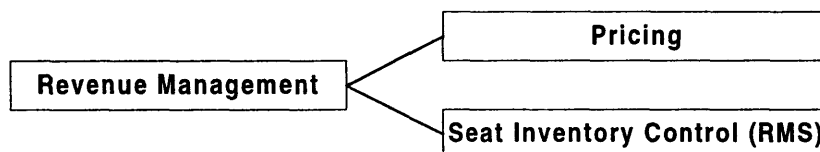

Figure 4.2. The two components of revenue management

Effective airline pricing requires monitoring competitors' fares in order to match prices, as well as applying the right travel restrictions to each fare class in order to minimize revenue dilution. Revenue dilution occurs when passengers willing to pay higher fares are not constrained by the specified travel restrictions and actually pay lower fares. Codesharing does not represent a critical issue for pricing, since codeshare flights can be priced the same way as normal flights are. Therefore, this section will not cover the pricing component of revenue management.

Seat inventory control can be found in many forms in the airline industry. In the two decades of revenue management history, the different methodologies for seat inventory control have evolved from the control of fare classes on a single flight leg to the control of seat inventories over a network of flights. However, the large investments in computerized revenue management systems designed to control by fare class on each leg independently and the obstacles derived from formal network optimization methods, have forced many airlines to slow down the shift from traditional yield management systems to more advanced ones (Belobaba 1998).

Figure 4.3 illustrates the major components of modern seat inventory control. Using historical information from a database, the demand for every future flight is estimated by forecasting models. These demand forecasts are then used as inputs to a revenue optimization model that determines the fare-class booking limits for each future departure flight.

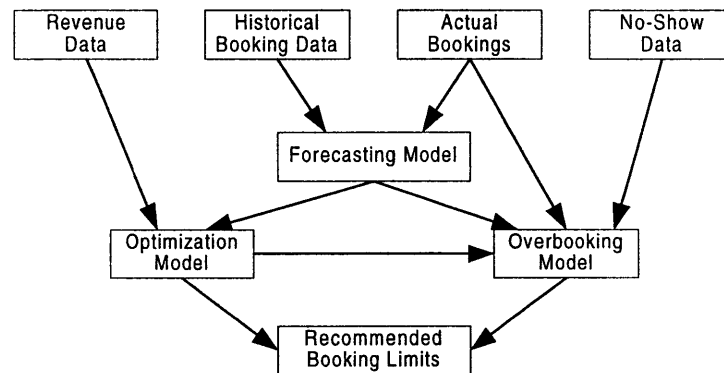

Figure 4.3. Major components of modern RMSs. Source: Belobaba (1998)

As was noted in the introduction, the discussion throughout the chapter will be focused on two revenue management methods representative of the state of the industry today. These are the conventional leg-based fare-class seat inventory control, and the more sophisticated origin and destination (O&D) seat inventory control with virtual buckets. This section intends to give to the reader a fast review of these two inventory control methods, enough to provide a minimum knowledge of their principles and enough to understand the different issues caused by the introduction of codesharing that are discussed in the next sections. The reader can refer to specialized articles, such as those of Belobaba (1987 and 1998), Williamson (1992), and Weatherford et al. (1992), which provide a more in-depth review of the different approaches for revenue management used in the industry.

4.3.1. Conventional Revenue Management

This method of seat inventory control is the logical evolution from prior-to-deregulation reservation systems, when most of the air traffic flew on direct flights.

Then, airline reservation systems had the mission to accept or reject booking requests for each class, on each flight independently.

Under conventional revenue management airlines have fare class control. They specify different *booking classes* that share a single aircraft cabin (economy cabin). An average yield (revenue per seat mile) for each fare class can be computed on every flight-leg, based on the forecast of demand for all the itineraries that traverse each leg. Then, each fare class offered by the airline is mapped to a corresponding booking class, being the number of booking classes less or equal than the number of fare classes. The average yields of all the fare classes mapped to each booking class provide an estimate of an average revenue contribution per passenger on each booking class. In the same way, the forecast of demand for all the fare classes mapped to each booking class provide a *mean* and a *variance* of demand for the booking class. These forecasts of demand and revenue contributions for each booking class of a specific leg are then fed as inputs into an optimization model that determines the booking limits (maximum number of seats allowed to be booked) for every booking class so that the revenue contribution on the leg is maximized. Figure 4.4 illustrates such a process.

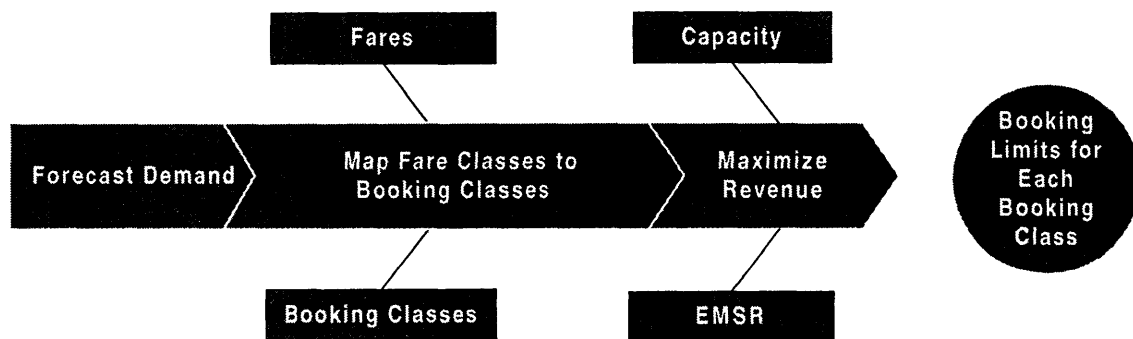

Figure 4.4. Booking limits determination under conventional revenue management

The most frequently used optimization model in the industry is the Expected Marginal Seat Revenue (EMSR) in its two versions: EMSRa and EMSRb (see Belobaba 1992). It sets up booking limits in a nested way so that the total seats made available to any booking class includes the seats made available to all lower classes. It assumes that

lower classes book ahead in time of higher classes. Thus, booking limits are determined so that the expected marginal revenue of increasing by one the seats left available to higher classes equals the average fare of the booking class whose booking limit is being determined.

The revenue management system of an airline is closely related to the reservation process, and therefore to the computer reservation system (CRS). Under conventional revenue management, when a seat is requested for a particular itinerary and fare (path-class request), the CRS of the airline looks for availability on the booking class corresponding to the fare requested in each leg of the itinerary independently. On any flight leg, availability of seats in a booking class means that passengers of any itinerary may book a seat in that class and then purchase a fare product associated with such booking class. In other words, bookings have not reached the associated booking limit. If the availability is non-zero in all the legs of the route, then the request is accepted and a seat is booked in every leg. Figure 4.5 illustrates the process.

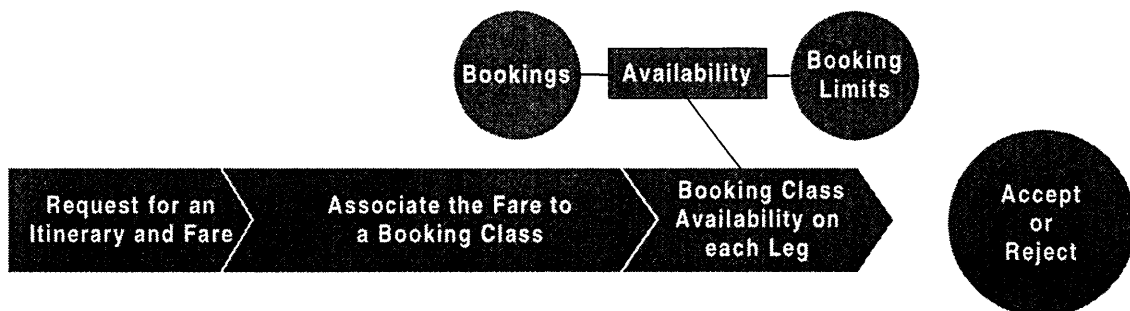

Figure 4.5. Reservation process under conventional revenue management

4.3.2. O&D Revenue Management

The conventional seat inventory control approach described above presents several shortcomings when used to maximize revenues over a network of flights. Williamson (1988) argued that maximizing revenues on each flight independently does not guarantee that total network revenues are maximized. Airlines, conscious of such limitations, have searched new ways to improve the leg-independent conventional

approach, particularly with the increase of connecting traffic through hub-and-spoke networks.

Most of the theoretical work done for O&D seat inventory control has been in the field of operations research (Belobaba, 1998). However, the application of pure network optimization techniques to the seat inventory control problem has limitations due to the large size of the mathematical problem involved and the small value of the decision variables. Consequently, instead of applying pure network optimization techniques, airlines have tried to improve their conventional revenue management systems by introducing network effects into the optimization algorithms. These improved seat inventory control processes, based on maximizing the network revenue, are called O&D revenue management systems, although they still control at the leg level. The difference is that the evaluation of requests and allocation of seats is no longer based on the fare class (or yield) but on different algorithms that take into account network effects.

The industry today uses different approaches for O&D revenue management. The discussion throughout this chapter is focus on O&D revenue management using *displacement costs* and *virtual buckets* (also called virtual classes). The reader can refer to Williamson (1992), Wei (1997) or Belobaba (1998), for further understanding of this approach.

The idea behind this method is to define a number of virtual buckets which can be common to every leg. A *network value* is assigned to every passenger forecasted to pass through each leg. Then, the network values are mapped to buckets in order to have an average network value and forecast of demand per bucket on each leg. And finally, booking limits are assigned to each bucket on every leg in order to maximize the total network value.

The network value of a path-class request is obtained by looking at the total revenue contribution of the request (the O&D fare) and subtracting the displacement costs associated with the path. The displacement costs are the opportunity costs of accepting

the request and taking one seat out of the inventory on all the legs of the path. Therefore, they represent an approximation of the revenue loss of decreasing by one seat the capacity of each leg in the path. The equation below captures the network valuation of a path-class request:

$$NV_{Path-Class}^l = BF_{O\&D} - \sum_{i \in Path, i \neq l} DC_i, \quad [4.1]$$

where $NV_{path-class}^l$ is the network value on the leg l of the path-class requested, $BF_{O\&D}$ is the base fare and represents the amount in dollars of the fare and O&D requested, and DC_i is the displacement cost of leg i . More sophisticated valuation approaches include carrying costs (basically meals and fuel) and recapture rates (rates that measure the probability of passengers choosing other paths if the request is denied).

The forecast of demand must be performed at the path-class level, providing a mean and variance of demand for each path-class. A *mapping table*, also called virtual-class table, must allow the system to allocate to buckets all the path-classes of the network and their forecasts. Then, an optimization model, such as EMSR, can be used to determine booking limits. Figure 4.6 illustrates the process described above.

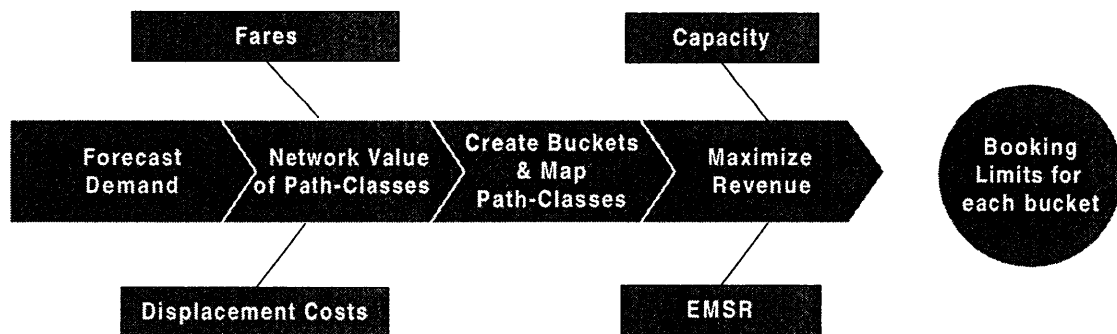

Figure 4.6. Booking limits determination under O&D revenue management with virtual buckets

At the CRS level the booking process is the following. When the CRS receives a path-class request, it first calculates the network value of the path-class. Then, using the mapping table, maps the path-class to a bucket. Finally, it determines availability for

that bucket on all the legs of the path. If such availability is non-zero in all legs, then the request is accepted, otherwise rejected. Figure 4.7 illustrates the process.

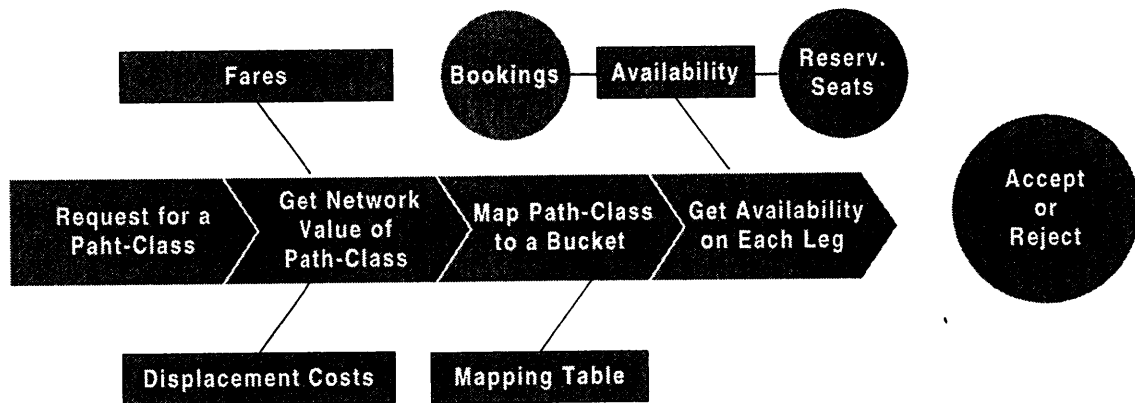

Figure 4.7. Reservation process under O&D revenue management with virtual buckets

4.4. Types and Aspects of Codesharing for Revenue Management

As discussed in the introduction of this chapter, the impacts of airline alliances on revenue management systems come from the introduction of codeshare flights in the partners' networks. In Chapter 1, the concept of codesharing was introduced. Here, this concept will be further elaborated to incorporate the aspects that are relevant for airline revenue management.

4.4.1. Types of Codesharing Agreements

The airline industry nowadays presents a large diversity of codesharing agreements, with little standardization or uniform criteria among airlines when defining methodologies for seat inventory control and revenue sharing. In this chapter, codesharing agreements will be differentiated based on two criteria: the method used for seat allocation between the alliance partners and the method used for revenue sharing.

4.4.1.1. Allocation Criterion

Codesharing agreements can be differentiated based on the way partners allocate seats to codeshare flights. Basically, there are two options. First, the operating carrier may reserve a fixed number of seats for the partner and let seat inventory control on such flights to the partner (block space agreement). Second, the operating carrier may control the entire seat inventory, providing availability on requests that have the code of the partner on an on-going basis (automated or “free sale” agreement).

Block Space Codesharing

Under block space codesharing, also called blocked seat allotment (Boyd 1998), the cabin of the aircraft is partitioned among carriers and each carrier is allowed to have individual control over the seats they have been assigned. It is frequent for both airlines to agree on having the block of seats guaranteed up to 3 or 2 days prior to the flight departure, when the operating carrier usually takes control of the entire inventory and sells those seats that were not booked by the partner. The agreement may specify a fixed block size or a flexible one. The risk of holding guaranteed seats until a few days prior to departure has forced airline partners to reach flexible agreements, where the partners specify a rather small initial block size, and request more seats as they sell out.

Operating carriers control only their own portion of the inventory. They block out a given amount of seats (specified in the agreement) that sold by the marketing carrier. Marketing carriers create a “*pseudo flight*” with capacity equal to the block space and send the flight information to the world’s CRSs. Essentially, marketing carriers handle the block space on the flight operated by the partner as a separate new flight. If a pseudo flight sells out, additional inventory is requested to the operating carrier, as discussed below. At an agreed time close to the flight departure, the marketing carrier returns unused inventory.

Because fixed block sizes are risky, most of the block agreements found in industry specify a flexible block size, in which the marketing carrier requests additional seats

when the block is filled. There are different approaches to expanding the block, and, depending on the way it is expanded, two types of block space agreements can be differentiated. The *block/manual* agreement is such that whenever the pseudo flight sells out, the analyst in charge must personally call his/her colleague in the airline partner and ask for additional inventory. The *block/automatically-updated* agreement involves automatic intercompany communication. When the pseudo flight sells out, a computerized system automatically looks into the partner's CRS. If lower classes are still open on the partner's flight (the carrier operating the flight), the system automatically expands the size of the block by a number of seats specified in the agreement.

Automated Codesharing

The automated codeshare agreement, also called "free sale" agreement, is a more dynamic alternative. The operating carrier allows the partner to access the inventory by providing information about availability in each booking class. Agreements frequently specify quota values that limit the number of seats to be booked by the partner marketing the flight when availability has been confirmed. In industry, is a general practice to use *availability status messages* (AVS) to communicate availability on codeshare flights.

For revenue management, the automated codesharing is different from the block space codesharing in that the operating carrier has control over the whole inventory. The marketing carrier receives requests on a codeshare flight and needs to ask for availability to the operating carrier. The criteria used to determine availability varies between agreements, though, within strategic alliances, seat allocation under free sale arrangements is aimed to provide a seamless control for all the alliance traffic.

As alliances enter the strategic dimension and key alliance groups consolidate their global networks, there is a general trend in the industry towards the increase of automated codesharing. Automated codesharing, if taken further beyond regular inter-line booking procedures, provides a greater benefit to the alliance from the sharing of

inventory. It lowers the risk of denied boardings, the risk of denied bookings while carrying empty seats, and it makes the alliance combined revenue be more easily maximized. However, to take automated codesharing beyond typical inter-line procedures through the establishment of interairline communications increases the booking complexity in RMSs and CRSs, and requires more sophisticated seat inventory control and reservation algorithms. Table 4.1 illustrates the trend towards automation, showing the distribution of agreement types at United Airlines in 1998. While United had agreements for automated codesharing with just a few partners (19% of them), the share of traffic through automated codesharing was the greatest.

Table 4.1. Distribution of agreement types within United Airlines.

| Agreement Type | Agreements | Traffic Share |
|------------------------------------|-------------------|----------------------|
| Block/Manual | 28.6% | 3% |
| Block/Automatically-updated | 52.4% | 44% |
| Automated | 19.0% | 53% |
| Total | 100.0% | 100.0% |

Source: United Airlines, 1998

4.4.1.2. Revenue Sharing Criterion

Another way in which codesharing agreements differ is in the revenue sharing method for codeshare flights. Again, here there are two main approaches: revenue sharing based on operating costs, and revenue sharing based on airline proration.

The revenue sharing problem is, in essence, the transfer pricing problem across units within a multi-business-unit corporation or an alliance. There are two traditional approaches to look at this problem: To treat the different units within the organization as cost centers or to treat them as profit centers (for further information read Eccles, 1983). The cost-based revenue sharing method is closer to the former approach, and it follows the philosophy that alliances should be “collaborative” partnerships where its members act together as one entity, which aims to maximize the combined revenue. The proration method, on the other hand, provides higher freedom to the alliance

members when establishing the criteria for revenue sharing, and in general, is closer to the profit center approach.

Cost-Based Revenue Sharing

Some airlines that operate aircraft over a same city-pair have adopted this approach. The idea behind this method is to treat the codeshare flights between the city-pair independently of the carrier operating the flight, focusing on maximizing combined revenues. Then, the alliance members split the revenues generated by codeshare traffic based on each carrier's operations in the corresponding city-pair. Revenue sharing based on costs is a very difficult process and, although aimed to favor the maximization of combined revenues, may lead to a "severely inequitable distribution of revenues and actually cause an alliance partner to lose revenue" (Boyd 1998). It also rises the difficult question of how to allocate revenue generated by connecting traffic to the leg that is codeshared. In addition, in most cases (if not all) cost-based approaches do not include in the cost evaluation the opportunity costs from the displacement of passengers in the rest of the network.

Inter-Airline Proration

Proration is the most common approach used by airlines to share revenues generated on codeshare flights. It is a logical evolution from interlining, where proration has been utilized for many years to allow free interline traffic and revenue accounting. In fact, the International Air Transport Association (IATA) formed the Prorate Agency in 1950, which is in charge of holding prorate meetings and keeping track of all interline agreements among carriers. The Prorate Agency publishes periodically a prorate manual that includes base amounts, prorate factors, and prorate agreements for all possible interline connections.

Basically, the practice of proration consists of setting prorate factors or base amounts that determine the split of the ticket fare among the carriers operating the flights of an

interline itinerary. The airline collecting the money from the passenger uses such prorates to determine how much of the passenger fare must be paid to each of the operating carriers for booking interline passengers in some of their flights. Prorate factors, multiplied by the passenger fare, provide the prorate amounts to be paid. Base amounts are directly the dollar amount to be paid. Both prorate factors and base amounts must be specified by leg and fare class for every carrier.

The application of interline proration to codesharing is similar. When there is a passenger booked on a codeshare flight, the carrier marketing the flight must pay to the operating carrier an amount given by the prorate agreement. There is a diversity of prorate methods to determine the amount to be paid, ranging from fixed percentages of the passenger fare to specific prorate formulations. Contrary to what seems a logical assumption, in a codesharing agreement between two airlines prorate approaches may not be uniform. In many cases, the prorate method differs from leg to leg within a network or even from class to class within a flight. There are three prorate methods that are most frequently used in codesharing:

- a) **Flat Amount.** The flat amount approach consists of setting flat dollar amounts to be paid by carriers marketing the flight, specified by fare class and for each codeshare flight.
- b) **Fixed Percentage of Fare.** This approach consist of setting prorate factors as percentages of the fare paid by the passenger. Such prorates factors are independent of the path and specified by fare class and codeshare flight.
- c) **Straight Rate Proration.** This approach consists of setting prorate factors, but instead of being fixed, are determined as a function of the mileage traveled by the passenger. The relative miles flown by the passenger on the codeshare flight are expressed as a percentage of the total path miles to give the prorate factor. Adjusting factors are usually introduced to obtain more desirable prorates.

Figure 4.8 below illustrates the three methods for alliance proration using an example. A passenger is traveling from Atlanta (ATL) to Zurich (ZHR) on a full coach fare (Y

class). Consider there are two potential codeshare itineraries: To fly with Airline X, which markets the codeshare flight operated by Airline Y on the JFK-ZRH route with its designator code (XX* 3100), or to fly with Airline Y, which markets the codeshare flight operated by Airline X on the ATL-JFK route with its designator code (YY* 3100). The first option will be considered as *Option 1*, and the second one as *Option 2*.

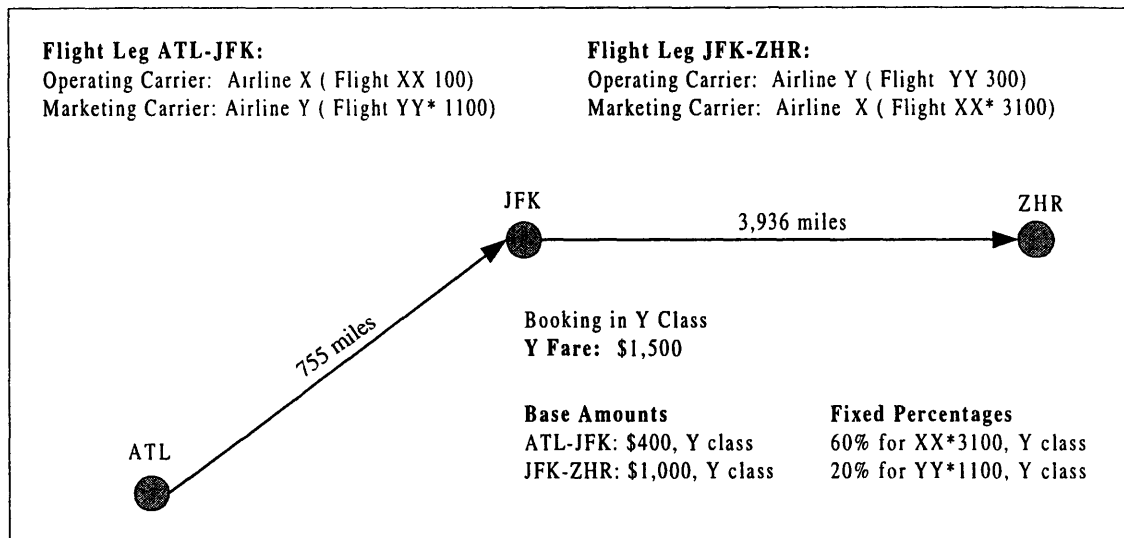

Figure 4.8. Example that illustrates the three proration methods

First, consider the proration method that is based on flat amounts. For Option 1, Airline X will have to pay to Airline Y \$1,000 for booking a passenger on its flight from New York to Zurich and will retain the remaining \$500 of the passenger fare. Under Option 2, airline Y will have to pay to Airline X \$400 for booking a passenger on its flight from Atlanta to New York and retain the remaining \$1,100 of the passenger fare.

Second, consider the proration method that is based on fixed percentages of the passenger fare. For Option 1, Airline X will have to pay to Airline Y \$900 (60% of \$1,500) for booking a passenger on its flight from New York to Zurich and will retain the remaining \$600 of the passenger fare. Under Option 2, Airline Y will have to pay to Airline X \$300 (20% of \$1,500) for booking a passenger on its flight from Atlanta to New York and retain the remaining \$1,300 of the passenger fare.

Finally, consider the proration method that is based on straight rate proration. For Option 1, Airline X will have to pay to Airline Y \$1,259 (equivalent to $(755)/(755+3,936) * \$1,500$) for booking a passenger on its flight from New York to Zurich and will retain the remaining \$241 of the passenger fare. Under Option 2, airline Y will have to pay to Airline X \$241 (equivalent to $(3,936)/(755+3,936)*\$1,500$) for booking a passenger on its flight from Atlanta to New York and retain the remaining \$1,259 of the passenger fare.

These examples illustrate how completely different approaches can be used to share the revenues generated from codeshare traffic. Under alliance itineraries of more than two legs, such as in multi-hub alliances, prorate methods often get more complex. In a hub-to-hub transatlantic scheme, such as the one presented in Chapter 3, it is a common practice to specify prorate amounts for the connecting legs (in any of the three forms presented above) and let the carrier operating the transatlantic flight retain the majority of the passenger fare.

4.4.2. The Two Aspects of Codesharing for Revenue Management

Codesharing presents two different facets that must be faced by RMSs in different ways, and that, consequently, require different seat inventory control approaches. Each of the aspects can be treated as a separate problem from a RMS point of view and, therefore, they must be clearly understood in isolation. The two aspects depend on whether the airline whose RMS is under analysis is the carrier marketing the codeshare flight or, on the contrary, is the carrier operating the codeshare flight.

Partner-Operated Codesharing

Under partner-operated codesharing (which can also be called *airline-marketed* codesharing or *[airline-code]** codesharing), the flight is operated by the partner and the airline markets the flight with its designator code. If the airline were Airline X and

its code XX, for example, the marketed flight will appear as an XX* flight in the passenger itinerary. Figure 4.9 the two aspects of codesharing through an example.

Airline-Operated Codesharing

On the other hand, under airline-operated codesharing (which can also be called *partner-marketed* codesharing or [*partner-code*]* codesharing), the airline operates the flight and the partner markets it using its designator code. If the partner airline were Airline Y and its designator code YY, for example, the marketed flight would appear as a YY* flight in the passenger itinerary.

The figure below illustrates the two aspects of codesharing for revenue management with an example. Although this example is somewhat unrealistic, since both airlines operate service on the two city-pairs, is useful for the purpose of identifying the different codesharing options. Consider a passenger desiring to fly from San Francisco (SFO) to London (LHR) connecting at New York (JFK).

Consider that the passenger can only take the two flights presented in the figure, the SFO-JFK flight operated by the airline under analysis, Airline X, and the JFK-LHR flight operated by the partner airline, Airline Y. While the passenger can only fly physically on one itinerary, there are four potential itineraries where he/she can be booked. The last of the four options, with the two legs being marketed by the carriers that do not operate the flight, does not represent a feasible option under the current regulation concerning codeshare agreements. However, in this example, it has been taken as a potential option to better illustrate the two aspects of codesharing.

From RMS point of view of the airline under analysis, airline-operated codesharing represents the challenge to determine availability for YY* requests on the flights operated by the airline and marketed by the partner. On the other hand, partner-operated codesharing represents the challenge to determine availability on the legs operated by the airline that are traversed by itineraries containing XX* flights.

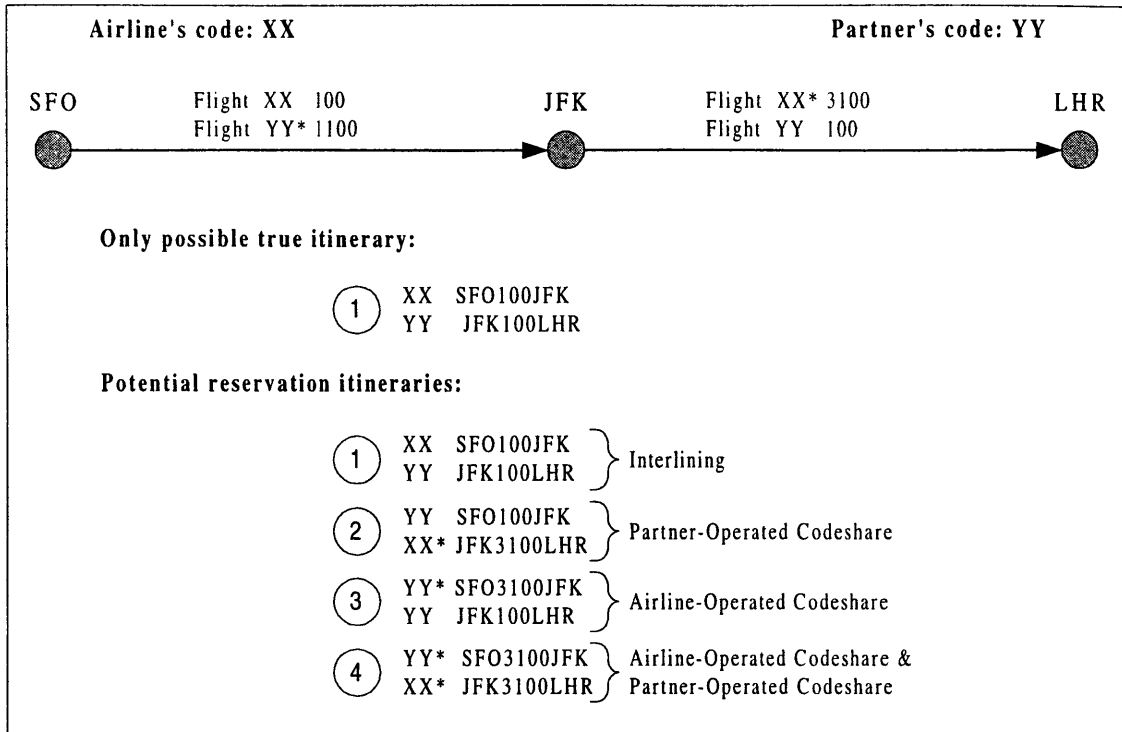

Figure 4.9. Example that illustrates the two aspects of codesharing for revenue management

4.5. Current RMS Approaches to Codesharing

Section 4.4 has presented the different types of codesharing agreements and the two distinct problems they represent for RMSs. Here, a review of the main steps taken by the airlines to face such problems is provided. As it happens with codesharing arrangements, different RMSs in industry present different approaches to handle codeshare traffic. It would be, therefore, a difficult assignment to synthesize all of them in this section. However, there are two main RMS approaches to codesharing that can be clearly differentiated, and that are presented below. The specific characteristics of each airline's RMS in the way it handles codesharing will allow us to consider such RMS as belonging to the corresponding approach.

4.5.1. Alliance Proration Approach

Throughout this chapter, the alliance proration approach will be used in reference to a broad number of approaches to handle codesharing, which essentially represent a further step beyond interlining. Basically, the term is used to include every approach that is not the fully integrated one, discussed in the next section. Although the degree of heterogeneity among those approaches that fall into this category is significant, there are some commonalities in all of them. The basic premise behind the alliance proration approach is that *alliance carriers control their own inventories and optimize seat allocation without considering the partners' demand*. Their systems aim to maximize their own network revenue instead of the combined alliance revenue. They employ a diversity of methods to determine seat availability on codeshare legs, ranging from block space to free sale codesharing agreements. Finally, for revenue sharing they employ proration, as was explained in Section 4.4. It is the most common approach found in the industry, due to its versatility for different codesharing types and its ease of use.

Critical Elements of the Alliance Proration Approach

- a) It is easy to implement into current revenue management systems. The treatment for codeshare requests is similar to that used for interlining. There is no interaction between revenue management systems, and therefore, the fact that each carrier uses a different revenue management system does not suppose an additional complication. For block space agreements, where seat blocks on codeshare flights are considered as pseudo flights, there is no need for intercompany communication at the CRS level. For automated codesharing agreements, where airlines must obtain availability from the partner, inter-CRS communication is required. However, similar formulas to those used for interlining can be used.
- b) There is no need for antitrust immunity, since approaches of this type rarely require coordination of compromising activities, such as pricing. Neither sharing of demand information and integration of systems are needed, since each carrier operates its

own RMS independently. Finally, the success of the codesharing activity depends mainly on the carrier itself, instead of the coordination, commitment and trust existing among alliance partners.

- c) The sharing of revenue is done through proration, and there are several techniques employed for such purpose. As pointed out in Section 4.4, the most frequent techniques used in alliance proration are the use of flat dollar amounts, fixed percentages of passenger fares, and straight rate proration. In many cases, the prorate amount is based on direct operating costs or mileage, which, as discussed in Section 9.4.1, presents several shortcomings. An alternative method is to prorate based on revenue instead of costs.

To set prorates based on revenue, the airlines operating the flights usually look at the average yields on the codeshare legs. One option is to use the average yield of local traffic. Yields on short-haul itineraries (local traffic) are higher than yields on long-haul itineraries. Therefore, if local passengers were displaced by codeshare traffic, the average local yield would represent a “fair” measure to determine the sharing of revenue among alliance partners (since it would represent the revenue that the airline operating the flight would have otherwise obtained from the seats occupied by the codeshare traffic). However, if local passengers are not being displaced, local yields will result in too high prorates for the marketing carrier. Another alternative is to define prorates based on the average yield of long-haul traffic. The problem here arises if there are local passengers being displaced, since prorates in such case will be too low for the operating carrier.

Additionally, the average yields collected by the partner in its network should also be considered. If the partner’s average yields were lower, any of the alternatives presented above would limit to small amounts the share of the passenger fare left for the partner. The purpose of this discussion is to illustrate the high complexity involved in the specification of prorates.

4.5.2. Fully Integrated Approach

Revenue management systems of airlines undertaking this approach value passenger requests independently of the airline operating the flight. They base their booking limit determination on shared information about the two partners combined demand. The premise behind this approach is to *do seat inventory control based on the forecast of the combined demand in order to obtain the maximum combined revenue*. Then, on a periodical basis, carry out revenue splits among the two carriers in order to share the benefits generated from the alliance codesharing practice. The work of Ferea (1996) focuses on multiple-hub codeshare alliances under this approach. Theoretically, the fully integrated approach is more in line with the concept of strategic alliances. However, for reasons that will be explained below, few airlines have adopted this approach. In fact, no carrier today has adopted a “pure” fully integrated approach.

Critical Elements of the Fully Integrated Approach

- a) It aims to obtain the maximum combined revenue, and therefore, should be the “preferable” approach if the alliance is considered as whole. However, current revenue management and reservation systems present many limitations that may hinder its implementation. In addition, maximizing combined revenue does not imply maximizing each partner’s revenue.
- b) It requires an exchange of information between both airlines in real time. Let’s assume that each carrier has control over the entire inventory of the aircraft it operates. The reservation systems of each airline must be able to communicate in real time in order to exchange availability messages for codeshare flights. In addition, every time booking limits are determined, the marketing carrier must provide actual demand information to the operating carrier. Such intercompany communication might require complex changes in the way current revenue management and reservation systems operate, exchange of technologies and methodologies, and standardization of systems and processes.

- c) It is easier to implement if the partners operate conventional RMSs. On the contrary, if they operate O&D RMSs, their systems must be able to share, besides fare information, network displacement costs. Consequently, the implementation of the fully integrated approach in this case is more complex. In addition, exchange of demand information at the O&D level requires significantly higher computational capacity. The implementation difficulties are even greater when one partner employs conventional revenue management, while the other partner employs O&D revenue management.
- d) It usually implies the coordination of other activities besides seat inventory control, pricing being one of them. Coordination of practices such as pricing requires permission from antitrust regulators. That is, antitrust immunity must be granted to the alliance. The US government traditionally has granted antitrust immunity to international airline alliances subject to the establishment of “open skies” agreements. Therefore, discrepancies between the US government and that of foreign alliance partners might hinder the approval of antitrust immunity and, in the bottom line, the implementation a fully integrated approach.
- e) It requires a high degree of commitment, trust, and organizational cooperation among alliance partners. The sharing of demand information, the exchange of technology, the standardization of processes, and the investment in the improvement of communication between CRSs requires alliance partners to look toward long-term partnerships. As alliances enter the strategic dimension and adopt a fully integrated approach, they demand from the partners significant commitment and willingness to carry out fundamental changes for the will of the alliance. Such degree of commitment might be difficult to achieve, particularly when alliances are formed as marketing devices, rather than as truly strategic, long-term partnerships.
- f) Techniques for the sharing of revenue are extremely difficult to determine. Probably this is the greatest hurdle for the implementation of the fully integrated approach. First, the allocation of revenue generated from a network of flights to a set of specific codeshare legs is a long-time-researched problem faced by airlines. It

is a problem caused by the dichotomy of supply and demand in air transport. Frequently, airlines use proration to split passenger fares among the flight-legs of their itineraries. Second, the revenue sharing method (whether is done through proration or other allocation technique) is mostly based on direct operating cost criteria, failing to include important factors. In particular, it fails to include the opportunity costs from booking codeshare traffic (displacement costs). Additionally, because the sharing of revenue is carried out periodically, even if displacement cost are taken into account, it will be extremely difficult to estimate the displacement costs of all traffic that traversed codeshare legs each period.

4.5.3. Comparison of the Two Approaches

Once the characteristics of each approach have been discussed in isolation, They are put together here in order to make a comparison between the two approaches. Ten critical aspects in which the two approaches differ have been identified. These are presented in the table below.

Table 4.2. Comparison of the two approaches

| Aspects | Proration | Fully Integrated |
|---------------------------------------|------------------------------------|-------------------------|
| Intercompany cooperation | Moderate | High |
| Trust required | Moderate | High |
| Intercompany communication | Not required | Required |
| Revenue split complexity | Medium | High |
| Passenger valuation complexity | High | Low |
| Maximum combined revenue | Lower | Higher |
| Interaction between CRSs | Required/not required ^a | Required |
| Long-term vision | Moderate | High |
| Investment | Lower | Higher |

^a Depends on whether is block space or automated codesharing

Table 4.2 seems to indicate that, in the short run, the proration approach provides more benefits than the fully integrated approach: There are less necessary changes to be made and the coordination among alliance partners does not need to be strong. However, in the long run, the fully integrated approach can be a better option: The

combined revenue is maximized and therefore, if the method used for revenue sharing is “fair” enough, each airline will improve revenues as much as possible.

There is a logical evolution from interline proration to alliance proration when the alliance is formed, and, as the alliance matures and enters the strategic dimension, a further evolution to more integrated methods. Figure 4.10 illustrates the author’s interpretation of what should be the logical evolution of the codesharing approach as the alliance matures.

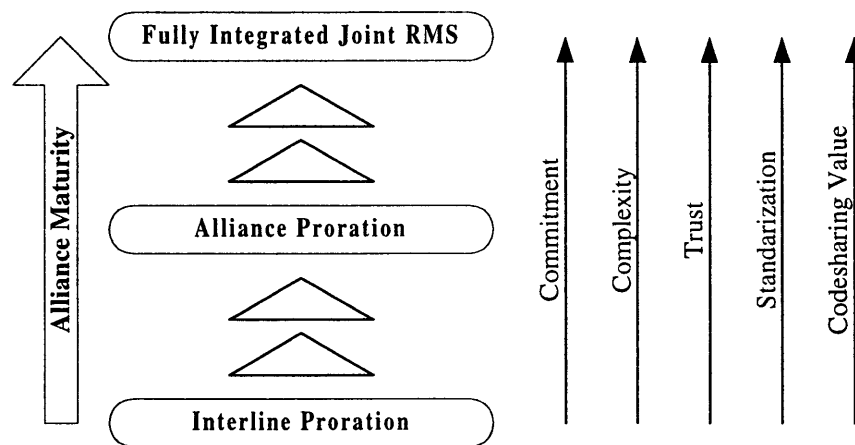

Figure 4.10. Logical evolution of the codesharing approach

Within the context of airline alliances, there is a continuous “tension” between two forces: The airline perspective and the alliance perspective. The alliance perspective looks at the two carriers as a whole and aims to maximize the combined revenue, while the airline perspective looks at each carrier independently and aims to maximize each airline’s revenue. The fully integrated approach is closer to the alliance perspective, while the proration approach is closer to the airline perspective.

There might be situations where the combined revenue of the alliance as a whole is maximized, yet one of the airlines might be worse off compared to another situation in which the combined revenue is lower. Figure 4.11 illustrates this with an example. What situation is best? It is clear that for a merger between two airlines the preferred alternative is the one that maximizes combined revenues. However, an alliance is not a

merger. For an alliance, the preferred alternative should be the one that maximizes the minimum of the airlines' revenues. This approach is well known in game theory as the *max-min* criterion. Then, if the objective of the alliance is to maximize each airline's revenue, it could be argued that the proration approach is more appropriate. However, it must be considered that the fully integrated approach, if used with an appropriate method for revenue sharing that overcomes all the shortcomings discussed in Section 4.5.1, would allow the revenue of each airline to increase as much as possible, yielding, at an ultimate state, the *max-min*. Whereas this is not assured under the proration approach.

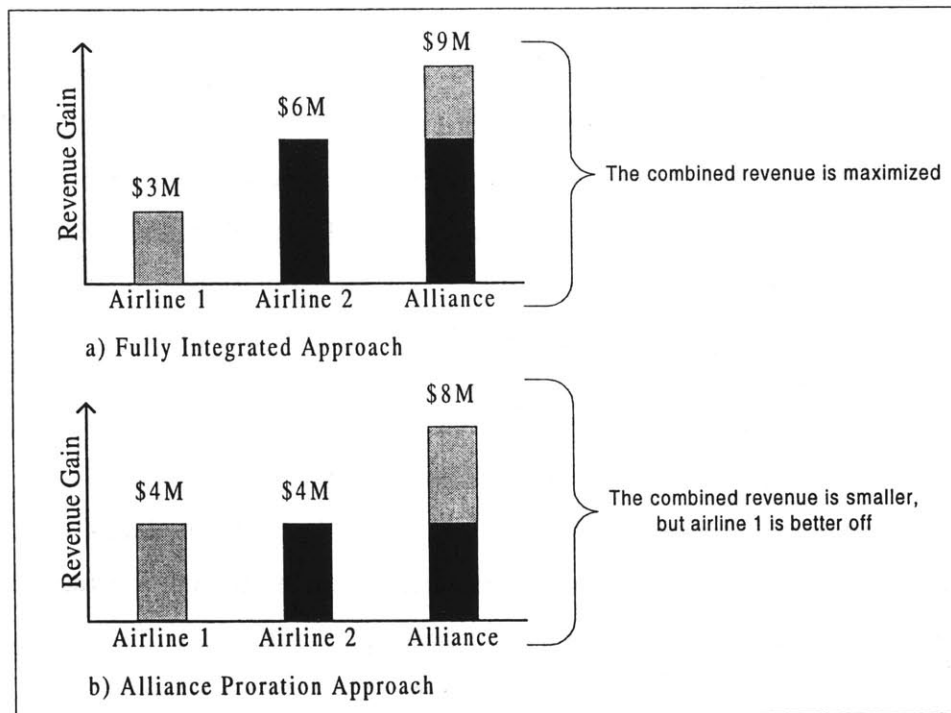

Figure 4.11. Illustrative example: airline perspective versus alliance perspective

Figures 4.10 and 4.12 help to explain the evolution of the RMS approach to codesharing as the tension between the airline and the alliance perspectives develops over time. In its first years of formation, where there is little trust and both carriers' systems are not prepared to operate in an integrated environment, the alliance is subject to a stronger "force" from the airline perspective, and consequently the preferred approach is the alliance proration. As the alliance matures and coordination between

airlines is easier and more effective, the alliance perspective is stronger and the codesharing approach evolves to the fully integrated approach, which will yield the maximum combined revenue and the maximum revenue for each airline.

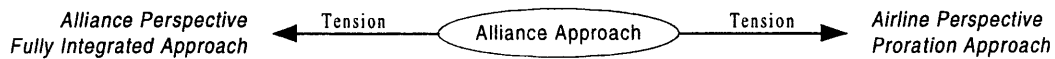

Figure 4.12. The tension between the airline perspective and the alliance perspective

4.6. Issues Concerning Seat Allocation Algorithms

In Section 4.5, the differences between the two approaches used by revenue management for codesharing and their main characteristics have been discussed. This section will assume that the economic terms of the codesharing agreement are fixed, and will focus on the details of the modeling approaches used by the RMS to meet such agreements in the seat inventory control process. The limitations of current approaches will be first addressed. Then, potential solutions will be proposed.

Previous research, mainly the work of Ferea (1996) and Boyd (1998), has focused on the modeling options to maximize the combined revenue of an airline alliance (the fully integrated approach). However, there is little research on the modeling alternatives to maximize revenue within alliances undertaking the more common proration approach. This section will address both approaches, although a larger part of the discussion will be focused on codesharing agreements under the proration approach.

The section is divided into three parts. The first two parts address the issues concerning seat inventory control within alliances undertaking the proration approach. In such case, the two aspects of codesharing addressed in Section 4.4.2 represent different problems for management, and they also require different modeling solutions. Therefore, the discussion has been divided into two parts; each of them focused on one of the two aspects of codesharing for revenue management. Finally, the third part addresses the issues concerning seat inventory control under the fully integrated

approach. Here, because passenger requests are treated the same way independently of the designator code of their ticket, the two aspects of codesharing for revenue management converge and have equal modeling solutions.

4.6.1. Partner-Operated Codesharing

Under the proration approach, each carrier operates its own RMS, and there is no interaction among the RMSs of alliance partners. Airline revenue management analysts face the challenge to perform seat inventory control and manage the traffic traversing the airline's network, including all codeshare legs, in order to maximize the airline's revenue.

In partner-operated codesharing, the airline receives requests for itineraries containing flight-legs with its designator code from the World's CRSs. Part of them are operated by the airline and the rest are marketed by the airline and operated by a partner. The RMS must determine availability in each of the legs traversed, for each itinerary requested. In the case of automated codesharing, it must ask for availability on codeshare legs to the operating carrier. In the case of block space agreements, it must determine availability on codeshare legs by itself, applying seat inventory control to the pseudo flights created for such purpose (see Section 4.4). The modeling approach used to set booking limits and to determine availability on itineraries that contain codeshare legs affects the seat allocation on both codeshare and non-codeshare legs. The section will focus on the ways that different modeling approaches impact the airline's revenue.

4.6.1.1. Current Limitations

The current modeling approaches used in industry to handle seat inventory control for itineraries containing codeshare legs present several shortcomings. Such shortcomings arise mainly due to two factors. First, there can be an incorrect valuation of the revenue contribution of codeshare traffic. Second, the effect of limited capacity for airline-marketed codeshare traffic on legs operated by partners is not taken into account.

Incorrect Valuation of Passenger Revenue Contribution

In general, airlines include codeshare traffic in their expected revenue formulations in the same manner they include ordinary traffic. As a consequence, the valuation of the revenue contribution of each passenger booked is based on its fare, independently of whether he or she is a passenger traversing a codeshare leg. However, the real revenue contribution for the airline comes from the O&D fare adjusted by the prorate amount that the airline, as the marketing carrier, must pay to the operating carrier.

This incorrect valuation of passenger revenue contribution implies a potential loss of network revenue, which is caused by an “overvaluation” of the codeshare traffic by the RMS of the airline marketing the flight. This revenue loss occurs only when non-codeshare traffic is spilled to accommodate codeshare traffic instead in other legs of the network. Hence, the loss of revenue due to an incorrect valuation of the revenue contribution of codeshare traffic is originated whenever there is spill of non-codeshare traffic on the non-codeshare legs of the network. Below, two examples illustrate such revenue loss. One example is in the context of conventional revenue management, while the other is in the context of O&D revenue management.

Conventional Revenue Management Example

An airline operating conventional revenue management looks at the yields of the traffic traversing its network. To do seat inventory control on a given leg, the RMS estimates for every booking class the average yield. Such booking-class average yield is the average of the yields of all the traffic traversing the leg whose fare classes are contained in the booking class. To simplify the analysis, it will be assumed that every booking class corresponds to just a fare class). This traffic might include some itineraries with codeshare legs. Therefore, because the RMS will not consider the prorate paid to the partner as discussed earlier, the average yields calculated for every booking class will be overestimated. As a consequence, booking classes containing a high concentration of codeshare traffic would be assigned larger booking limits than those obtained if RMS

were based on the real revenue contribution of codeshare traffic. In the bottom line, it implies a potential revenue loss for giving high booking preference to codeshare traffic.

Figure 4.13 illustrates such loss of revenue with a simple example. It replicates the seat inventory control process for a leg with 4 seats available that is traversed by two types of traffic: Local traffic (XX 100 SFO-DFW) and connecting traffic (XX 100 SFO-DFW connecting on XX* 1100 DFW-JFK). The demand information of such traffic is given in Table (a). For simplicity in the analysis, it has been assumed that each leg is equally long (1,000 miles). Equally, it has been considered deterministic demand and booking classes equal to fare classes. The airline does not operate the leg 1100 DFW-JFK, so that all connecting traffic is also codeshare traffic, and the airline must pay a prorated amount to the operating carrier (\$300 for Q class). In order to estimate the booking limits on the leg 100 SFO-DFW, the RMS must first estimate the average yield on every booking class from the traffic traversing the leg. Once an average yield and expected demand have been estimated for every booking class, the booking limits are calculated in order to maximize the average revenue contribution on the leg (Table c).

As is shown in Table b, the average yield for the booking class containing codeshare traffic (class Q), which is estimated from the passenger fares, is higher than the average yield for the class V. However, taking into account prorates, the average yield for class Q, which now is obtained using the true revenue contribution—that is, fares adjusted by prorates, is lower than the average yield for class V. In consequence, under the current valuation method, the RMS will overestimate the value of the class Q, giving to such class higher availability on the leg 100 SFO-DFW than to class V. Table (c) shows the different seat allocation outputs from the RMS in two cases: When RMS values codeshare traffic using the current approach—that is, without considering prorates, and when RMS values codeshare traffic discounting the prorates.

In the first case, the seat allocation that maximizes the average revenue on the leg is to reserve the entire inventory of 4 seats for class Q (which has the greatest average yield). The RMS will maximize the average leg revenue based on the passenger fares to

\$1,100. However, the true average leg revenue obtained when prorates are discounted would be only \$800 for this seat allocation.

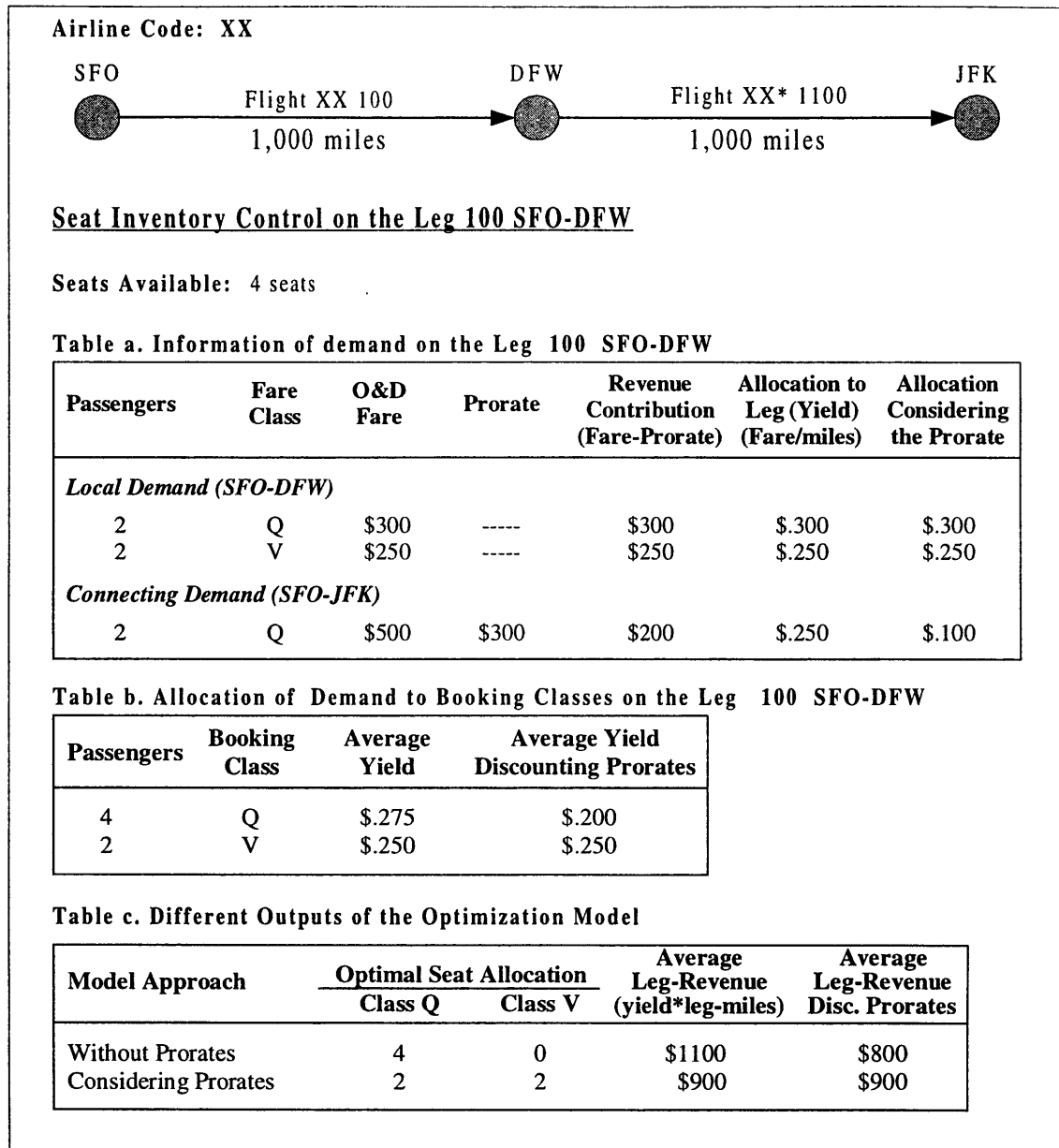

Figure 4.13. Incorrect valuation of the passenger revenue contribution. Conventional RMS

In the second case, the output of the RMS will be to reserve two seats for class V and leave the remaining 2 seats for class Q. The RMS will maximize the average leg revenue to \$900, which, in this case equals the true average leg revenue. Therefore,

because the RMS does not consider the prorata paid to the partner, there is a revenue loss of \$100 in terms of average leg revenue.

Note that because the booking sequence for each class and itinerary is uncertain, it is only possible to express the revenue loss in terms of the average leg revenue. In order to measure the real revenue impact it would be needed to know the order of bookings for each class and itinerary. Consider, for example, that the two passengers desiring to fly from San Francisco (SFO) to Dallas (DFW) on Q class request a seat ahead of the 2 passengers desiring to travel from San Francisco (SFO) to New York (JFK) on Q class (codeshare traffic). Under this scenario, for the seat allocation considered first (without discounting prorates) the total revenue collected would be \$1,000 ($2 \times \$300 + 2 \times \200). For the second seat allocation, however, the total revenue collected would be \$1,100 ($2 \times \$300 + 2 \times \250). Therefore, the total revenue loss would be \$100 in absolute terms.

The example presented in Figure 4.13 can be used to highlight another source of incorrect valuation for codeshare traffic under conventional revenue management: The estimation of the yield of codeshare traffic. Conventional RMSs often allocate to the leg the passenger fare, which is given at the O&D level, by estimating the passenger unit revenue per mile flown (the yield). In Figure 4.13, the yield of the connecting passengers (the codeshare traffic) has been estimated as the passenger fare divided by the total miles of the O&D market (2,000 miles). However, the codeshare traffic only flies the first leg of the itinerary on aircraft operated by the airline. Therefore, a more realistic measure for the operating airline of the passenger unit revenue would be to divide the passenger fare by the length of just the portion of the itinerary that is operated by the airline (1,000 miles). Note that this would be equivalent to considering the codeshare traffic as local instead of connecting traffic from a RMS point of view.

O&D Revenue Management Example

An airline operating O&D revenue management looks at the network value of every request for an itinerary and fare (path-class). Such network value for the leg l being optimized is given by Equation 4.1, presented earlier:

$$NV_{Path-Class}^l = BF_{O\&D} - \sum_{i \in Path, i \neq l} DC_i$$

The RMS determines the booking limits of each virtual bucket on a leg based on leg network values of the path-classes traversing the leg. When there is a request for a path-class, its booking preference over other requests is given by the corresponding bucket assigned to it, which in turn is determined by the network value of the path-class requested. Because the network value calculation does not take into account prorates for codeshare traffic, the network values of path-classes traversing codeshare legs will be high compared to true revenue contribution of codeshare traffic. Furthermore, they could be higher than the network values of other path-classes not traversing codeshare legs with higher revenue contribution. In such case, codeshare path-classes would have higher booking preference than the other path-classes, while providing lower revenue to the airline. Therefore, there is a clear potential revenue loss due to the displacement of non-codeshare traffic in favor of codeshare traffic.

Figure 4.14 illustrates this revenue loss with an example. It presents a situation where there are two path-class requests that traverse the leg XX 100 SFO-JFK, which has only one seat available. The RMS will allocate the free seat to the path-class with the highest network value.

The displacement costs on the legs XX* 3100 JFK-LHR and XX 150 JFK-MAD are assumed to be zero, since the demand on those legs is low. If codesharing prorates are not taken into account, request 1 will have a higher network value, since its fare is \$500 higher (\$2,000 Vs \$1,500). However, if prorates are taken into account, request 2 will have a higher network value, since it will be based on the adjusted passenger fare that is \$500 higher for request 2 (\$1,500 Vs \$1,000). Therefore current RMSs will assign the only seat free to request 1, interpreting that its network value is greater. In essence, there would be a revenue loss of \$500, expressed as the difference between the revenue contribution of both requests.

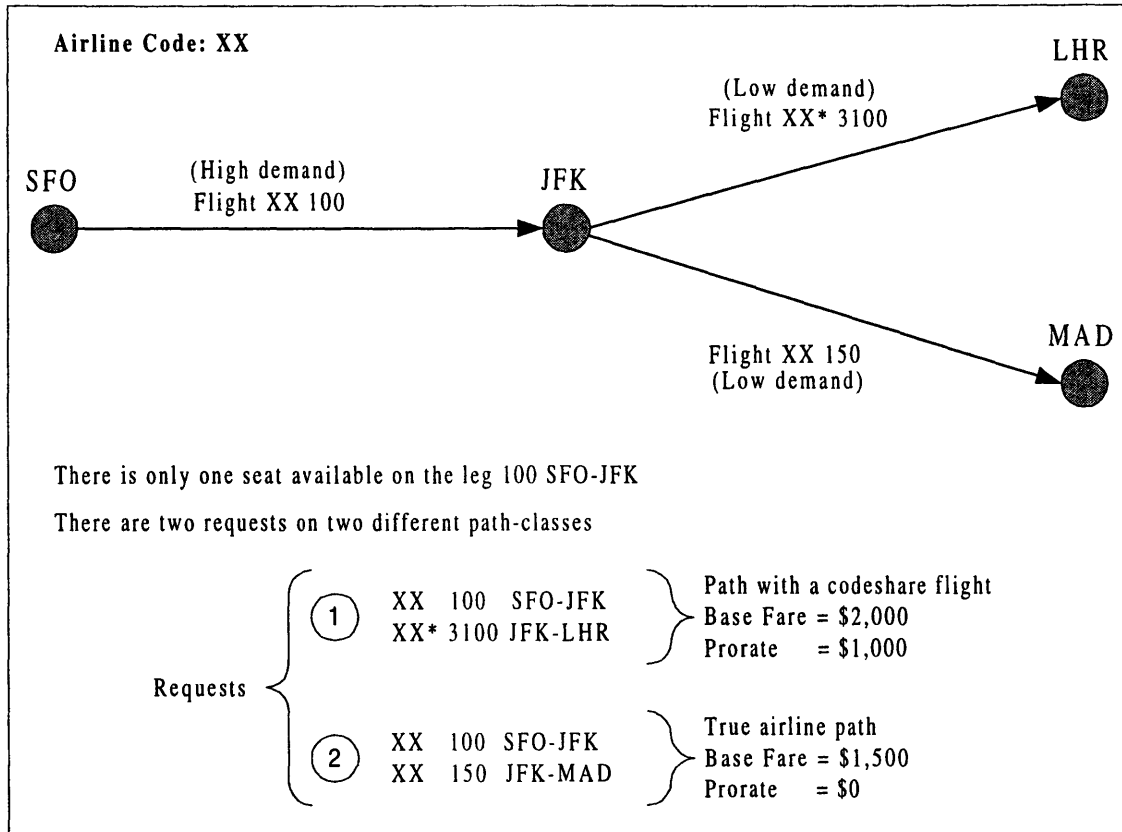

Figure 4.14. Incorrect valuation of passenger revenue contribution under O&D revenue management

To further elaborate on the problems arising from an incorrect valuation of the passenger revenue contribution, the following common problem is presented: Both alliance partners operate on the same city pair (parallel codesharing), for example JFK-LHR. The airline under analysis will market flights in that city-pair both operated by it and operated by the partner. Consider that each carrier operates a flight within a given time window, and let's focus at one of them. The airline, whose designator code is XX, will market the following flights: XX 160 JFK-LHR and XX* 3100 JFK-LHR. Under current valuation approaches and for some O&D requests, RMSs would give higher preference on the leg 100 SFO-JFK to codeshare paths traversing the leg 3100 JFK-LHR than to non-codeshare paths traversing the leg 160 JFK-LHR. This is due to the fact that passenger O&D fares are equal in either case, but carrying costs and displacement costs on the codeshare leg are considered to be zero.

Both examples, the one for conventional revenue management and the one for O&D revenue management, have shown that current modeling approaches for seat inventory control of codeshare traffic present several shortcomings. There are potential revenue losses arising from such shortcomings; revenue losses that are mainly due to an “overvaluation” of the codeshare traffic by not taking into account the prorates that must be paid to the operating carrier. How large would such revenue losses be? That would depend on the specific characteristics of the network and the volume of codeshare traffic.

Uncertain Capacity of Codeshare Legs

In general, marketing carriers in an alliance do not know how many seats will the operating carrier allow them to book with their designator code on a codeshare flight. Here, such number of seats will be referred as the “capacity” or “pseudo capacity” of the codeshare leg (from the point of view of the marketing carrier). Only in those cases where codesharing agreements specify a fixed block size for the entire booking period, that capacity will be certain. However, as was pointed out in earlier sections, block space agreements seldom specify static block sizes.

The impacts of having a variable capacity on codeshare legs are listed below:

- In the case of *block space agreements* with automatic update, RMSs create pseudo flights and apply seat inventory control on them. As discussed in Section 4.4.1, the initial block size is small and, as the marketing carrier request more seats, the “capacity” of such pseudo flights increases with time. One impact of this capacity variability is that, in early stages of the booking period, the booking limits will be more restrictive than later on, and consequently, part of the demand could be spilled in the early stages unnecessarily. To avoid dealing with such uncertainty, some airlines assume infinite capacity and accept any request on the codeshare leg. When the block is full, they request more seats to the partner. This is the source of the second impact, contrary to the first one. Here, the revenue loss can arise from lacking empty seats at the end of the booking period and consequently spilling

high-yield later-booking passengers. In both cases, there is a potential revenue loss due to a wrong determination of the booking limits due to an uncertain pseudo flight capacity.

- In the case of *automated codesharing*, the impacts of uncertain capacity on codeshare legs are different depending on the type of revenue management used. For conventional revenue management there is no potential impact, since it is the RMS of the partner which determines seat availability on the codeshare legs, and having uncertain capacity on the codeshare legs does not affect the seat allocation process in the other legs of the network. However, for O&D revenue management there is an impact that should be considered. Since there is no fixed limitation in the number of airline-marketed bookings on codeshare legs, airlines using O&D RMSs generally employ a zero value for displacement costs on codeshare legs. Williamson (1992) showed that when displacement costs are not taken into account, local traffic might be spilled in favor of connecting traffic that contributes with lower network revenue. Figure 9.15 illustrates this fact with an example.

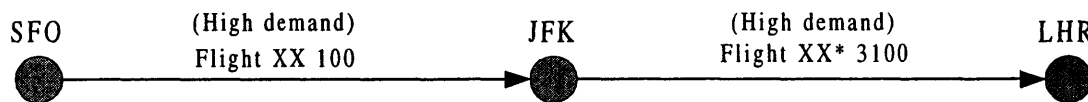

Figure 4.15. Impact of uncertain capacity on codeshare legs

If local demand is high on the codeshare leg 3100 JFK-LHR, because the displacement costs of such leg are taken as zero (when they are not), the network value of connecting traffic could be higher than that of local traffic with higher combined revenue. Therefore, local passengers in both legs 100 SFO-JFK and 3100 JFK-LHR providing together a higher revenue contribution than connecting passengers could be spilled in favor of the latter ones, and there would be a revenue loss. The work of Williamson further elaborates on the impacts of displaced demand on network revenue.

The two sources of revenue loss that can be encountered on codeshare traffic have been addressed above. The revenue loss originated from an incorrect valuation of the passenger revenue contribution is originated in the seat allocation on the non-codeshare

legs. On the other hand, the revenue loss from uncertain capacity of codeshare legs is mainly originated in the seat allocation on the codeshare legs.

4.6.1.2. Potential Solutions

Once the limitations of current systems have been addressed, the next step is to explore potential RMS improvements to reduce the revenue loss from such limitations. Here, two alternatives are explored: the proration of the passenger fare and the estimation of the “pseudo capacity” of the codeshare leg. They are intended to be mere propositions, as first development steps that will mark the direction for future research in this area.

Proration of the Passenger Fare

The proration of the passenger fare consists of adjusting the O&D fare paid by the passenger with the prorate paid by the marketing carrier to the operating carrier. In other words, subtract from the passenger O&D fare the proration amount that must be paid to the operating carrier, and use this new prorated base fare instead of the O&D base fare for seat inventory control:

$$BF_{PR} = BF_{O\&D} - PR \quad [4.2]$$

where BF_{PR} is the prorated base fare, $BF_{O\&D}$ is the passenger fare for the itinerary and PR is the prorate amount. Depending on the type of revenue management used, the application of the proration process will be different, as it is explained below.

Conventional Revenue Management

Booking limits are established for booking classes, which are determined by fare classes. By prorating the passenger fare, the average yield of booking classes represents a more realistic measure of the real passenger revenue contribution. However, the proration of the passenger fare raises additional problems for the RMS.

For example, if prorates are high, average yields of booking classes containing high levels of codeshare traffic will be low. In that case, it could happen that such booking classes have less average yield (once prorates have been taken into account) than booking classes mapped to lower fare classes. In fact, this happened in the example of Figure 4.13, where the booking class associated to the fare class V—which in the example was a fare class lower than Q, once prorates were taken into account, had a higher average yield—and consequently higher priority in the seat allocation process—than the booking class associated to the fare class Q. This problem could lead to confusion within RMSs, and might go against the revenue management basic assumption that passengers of low-yield booking classes book ahead in time of passengers of high-yield booking classes (Belobaba 1987).

In addition, non-codeshare passengers of high fare-classes allocated to the same booking class as codeshare traffic with high prorates could receive an “unfair” preference treatment in the seat allocation process due to the lower yields of the codeshare traffic. For example, consider that the airline uses the fare codes B and M, with M a lower class than B. On a given leg with a high degree of codeshare traffic traversing the leg on the B class but not on the M class, a local high-yield B-fare passenger could be spilled in favor of a local lower-yield M-fare passenger.

In order to solve this problem, a more complex method of allocating demand to booking classes is necessary. Instead of assigning booking classes to codeshare traffic based on the fare class itself, it should be done based on the value of the prorated fare. This could be achieved through the implementation of a process that identifies codeshare traffic, prorates its fares, and, in order to map codeshare traffic to booking classes, it maps the codeshare traffic to a fare class that has similar fare values as the prorated fare. Figure 4.16 illustrates this process through a block diagram. Note that this solution is very similar to the establishment of virtual buckets, as described for O&D revenue management. Therefore, the implementation of such process will suppose a decisive step in the airline’s RMS development in shifting from conventional revenue management to more advanced O&D systems.

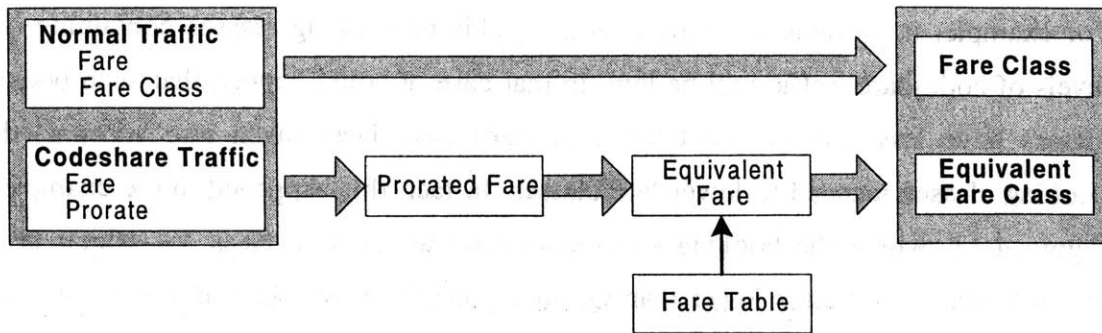

Figure 4.16. Determination of equivalent fare classes for codeshare traffic

O&D Revenue Management

For O&D revenue management, removal of the of passenger revenue miss valuation can be achieved through the introduction of prorate amounts into the network value formulation. Therefore, the proposed alternative formulation is as follows:

$$NV_P^l = (BF_{O\&D} - PR_P) - \sum_{i \in P, i \neq l} DC_i, \quad [4.3]$$

where NV_P^l is the network value for the leg l of the path-class requested P , $BF_{O\&D}$ is the passenger base fare for the O&D, PR_P is the prorate amount that the airline must pay to its partners from the prorates of all the codeshare legs that are included in the itinerary P , and DC_i s are the displacement costs on all the legs of the itinerary P but l . RMSs can then use this formulation to assign path-class requests to buckets that really represent the passenger revenue contribution. Figure 4.17 illustrates the process that should be carried out within the RMS under the new passenger valuation.

For every path-class request, the RMS will have to identify the O&D passenger fare, the displacement cost of the legs contained in the itinerary, and then if there are codeshare legs in the path, identify the carrier operating such legs and obtain the prorate amount that must be paid. Then, compute the network value of the path-class and allocate seats accordingly.

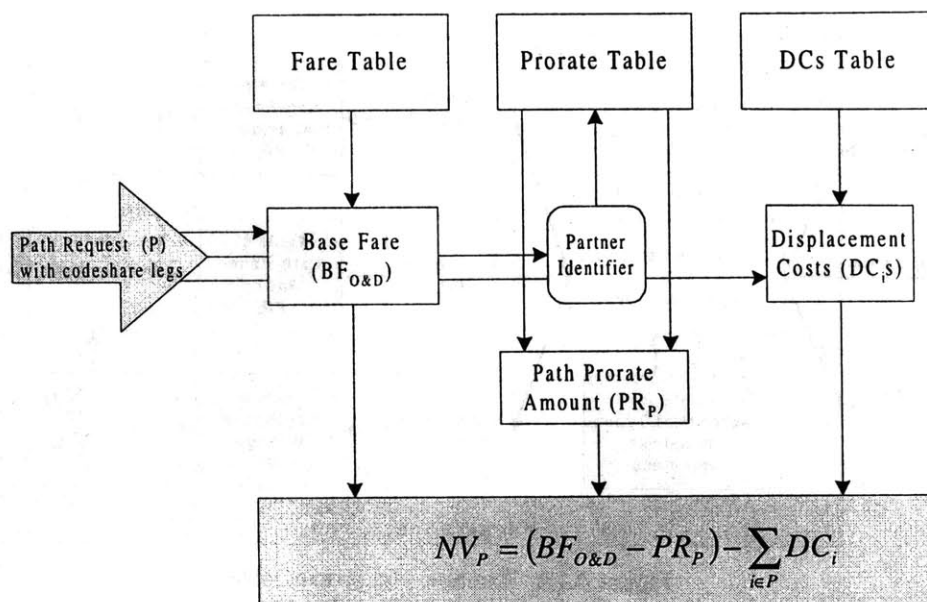

Figure 4.17. New path-class valuation process

The proration of the base fare alternative represents a strong option to reduce the revenue loss originated from codeshare traffic. However, in order to implement such alternative into the RMS, a database (prorate table) where the RMS can look at and extract prorate amounts for any given path-class will be needed. That is true for both conventional revenue management and O&D revenue management. Here, a possible configuration of such prorate table is proposed. Under the assumption that there will be only the three types of proration methods for codesharing explained in Section 4.4.1, Figure 4.18 illustrates the functional steps of the proposed prorate table.

The prorate table would have as inputs the O&D passenger fare, the carrier operating the flight, and the itinerary and fare class of the request. Once the inputs are given, the next step is to identify the agreement type for the given operating carrier and fare class on all the codeshare legs of the path. Then, extract all the proration parameters specified in the agreement. Finally, the prorate amount for the path-class requested is computed based on the agreement type. For flat dollar amounts, the total prorate amount for the path is the sum of prorate amounts for each codeshare leg contained in the path. For fixed percentage of the passenger fare or straight rate proration, the total prorate amount for the path is a fraction of the passenger fare for the O&D.

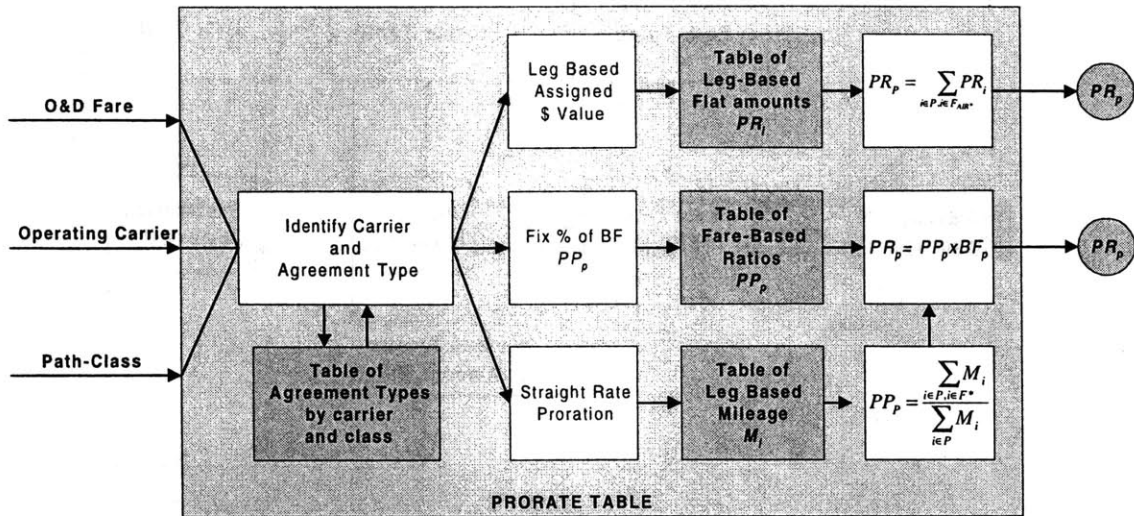

Figure 4.18. Example of a prorate table

Estimation of “Pseudo Capacity” on Codeshare Legs

The estimation of the “pseudo capacity” of codeshare legs consists of looking at the history of bookings on such legs and applying forecasting techniques to determine the expected number of seats that the operating carrier will allow the marketing carrier to book. This expected value can be taken as a “pseudo capacity”, which then can be used to protect seats for higher classes that book closer to the departure date. In such forecasting effort, it would be extremely valuable to have specified in the history of bookings those departure dates where the flight was closed for the marketing carrier. In those dates, the level of bookings can be taken as reliable measure of a “pseudo capacity”. Here, the analysis is divided into two parts depending on the type of codesharing agreement.

Block Space Agreements

For block space agreements with block sizes automatically updated, the estimation of maximum expected bookings on codeshare legs will allow to set pseudo flights with constant capacity throughout the entire booking period, and apply seat inventory control as if they were non-codeshare flights. This can be done for both conventional and O&D revenue management systems. However, the final number of bookings on the

codeshare leg is a random variable, which introduces uncertainty to the actual value of the pseudo capacity. To deal with this uncertainty additional adjustments could be incorporated. For example, instead of taking as the pseudo capacity the expected value of the constrained demand obtained through statistical analysis, it should be preferable to add a *security buffer*. Moreover, revenue management analyst should be able to adjust the buffer depending on the market conditions and the desired risk of spill. Figure 4.19 represents in a flow chart the application of the security buffer.

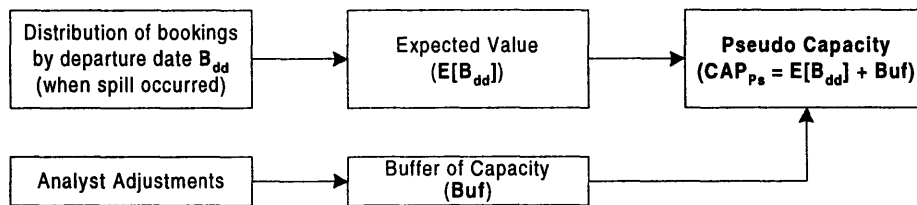

Figure 4.19. Adjustment of the pseudo capacity on codeshare legs

Analyst adjustments should be based on the variability of constrained demand on departure dates when flights were closed. However, this variability might be significant in practice. In such cases there would be little benefits from estimating the pseudo capacity of codeshare legs. In addition, the supply of demand information specifying those departure dates when flights were closed might be extremely difficult to obtain. An alternative then is to use the history of bookings in all departure dates. However, this would increase variability and would make the measure of the pseudo capacity unrealistic.

Automated Codesharing Agreements

To estimate the pseudo capacity on codeshare legs under automated codesharing is not such a critical issue, since the airline lets the partner decide on the availability for each of its requests. Always that there is trust among partners in the way they provide availability for codeshare flights there is no need to estimate pseudo capacities and carry out inventory control—the partner does it. However, in most cases, the partner will lack network information about the airline’s codeshare traffic and its availability

determination might not be efficient. In particular, the partner will not be able to differentiate between local traffic and connecting traffic within the airline's network. Therefore, the airline should try to include such network effects into the valuation of codeshare traffic before asking for availability to the partner. For airlines operating O&D RMSs, it would be useful to have estimates of the displacement costs on the codeshare legs operated by the partners in order to avoid spill of local traffic in favor of connecting traffic whenever it represents a revenue loss (as explained in section 4.6.1.1). Using displacement costs on codeshare legs, the network value formulation of a path request will be as follows:

$$NV_p^l = (BF_{O\&D} - PR_p) - \sum_{i \in P, i \in F, i \neq l} DC_i - \sum_{i \in P, i \in F^*, i \neq l} DC_i^* \quad [4.4]$$

where DC_i^* is the displacement cost of codeshare leg i estimated through the pseudo capacity, F is the set of flights operated by the airline, and F^* is the set of codeshare flights operated by the partner. The rest of elements in the equation are the same as those of equation 4.3. It is worth noting that in automated codesharing there is more variability on the number of codeshare bookings than in block space codesharing, since there are no predetermined block sizes in the agreement. Figure 4.20 illustrates the high variability of bookings over a codeshare leg of a large airline.

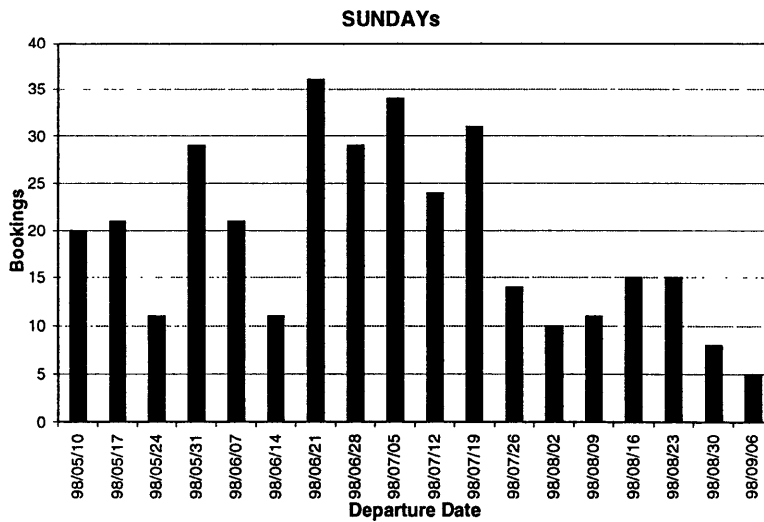

Figure 4.20. Bookings per departure date on a codeshare city-pair under automated codesharing (Source: United Airlines)

4.6.1.3. Simulation results

The solution approaches proposed above were tested using simulation techniques at one large airline. A simulator replicated the seat inventory control and booking process for a given network at one departure date using O&D revenue management with virtual buckets. Equation 4.4 was introduced into the simulator model, which could be run under four different options: Without considering changes (treating codeshare traffic as normal traffic); considering fare proration but not displacement costs on codeshare legs; considering displacement costs but not prorates on codeshare legs; and finally, considering both prorates and displacement costs.

The simulation was carried out on a small network consisting of 7 legs and 24 O&Ds. The demand used in the analysis was built following reasonable assumptions to emulate scenarios that reflect real situations. It was randomly assigned in order to have an overall network projected load factor of 70%. The fare information and prorates were real figures used by the airline.

The simulation results showed that the main gains from the proposed solutions were found in the proration of the base fare, while the estimation of displacement costs from the pseudo capacity of the codeshare legs did not have a significant impact on revenue. In the overall network, significant gains were found when the proposed model was applied. These results proved that the current proration levels used in industry and the way codeshare traffic is handled by RMSs may be a significant source of revenue losses, which airlines might be unaware of. The simulation results supposed an important piece of empirical evidence in support of this chapter's assertion that the improvement of RMSs in the way they handle codeshare traffic has become a critical issue.

4.6.2. Airline-Operated Codesharing

Under the airline-operated aspect of codesharing, the airline receives partners' requests to book their passengers on flights that it operates. Generally, the only information that

the operating airline receives is the fare class of the request, lacking additional information about passenger O&D fares, itineraries, or network effects. For block space agreements there is no significant impact on RMS, since the airline operating the leg is not involved in the allocation of partner-marketed codeshare requests. Therefore, this section will focus on the automated codesharing, assuming that the economic terms of the codesharing agreements are fixed.

4.6.2.1. Current System Limitations

The general practice in the industry is to treat codeshare traffic marketed by partners as it would be local traffic on the leg. Therefore the allocation technique used, both in conventional and O&D revenue management, is to consider codeshare traffic the same way as local traffic on the same fare class. Then, assign booking preferences to such codeshare traffic as a function of the corresponding local fares. This procedure presents several shortcomings, as shown in the example below. An additional complexity in the allocation procedure is that, frequently, codesharing arrangements determine availability for codeshare traffic on a city-pair basis rather than on a leg basis. If the operating carrier operates several legs in a same city-pair, it would be complex to combine all legs' traffic to determine booking preferences for partner-marketed codeshare traffic.

Here, it will be assumed for simplicity that availability exchanges are performed at a leg basis rather than at a city-pair basis. As it happened in the case of airline-marketed codesharing, potential revenue losses arise from an incorrect valuation of the revenue contribution of codeshare traffic. The real revenue contribution of partner-marketed traffic for the operating carrier is the prorate amount it receives from the marketing carrier. Generally codesharing prorates are lower than average local fares on the same fare class as the codeshare traffic; therefore, current RMSs value codeshare traffic higher than the non-codeshare traffic that provides the same revenue contribution to the airline. Figure 4.21 illustrates this fact with an example.

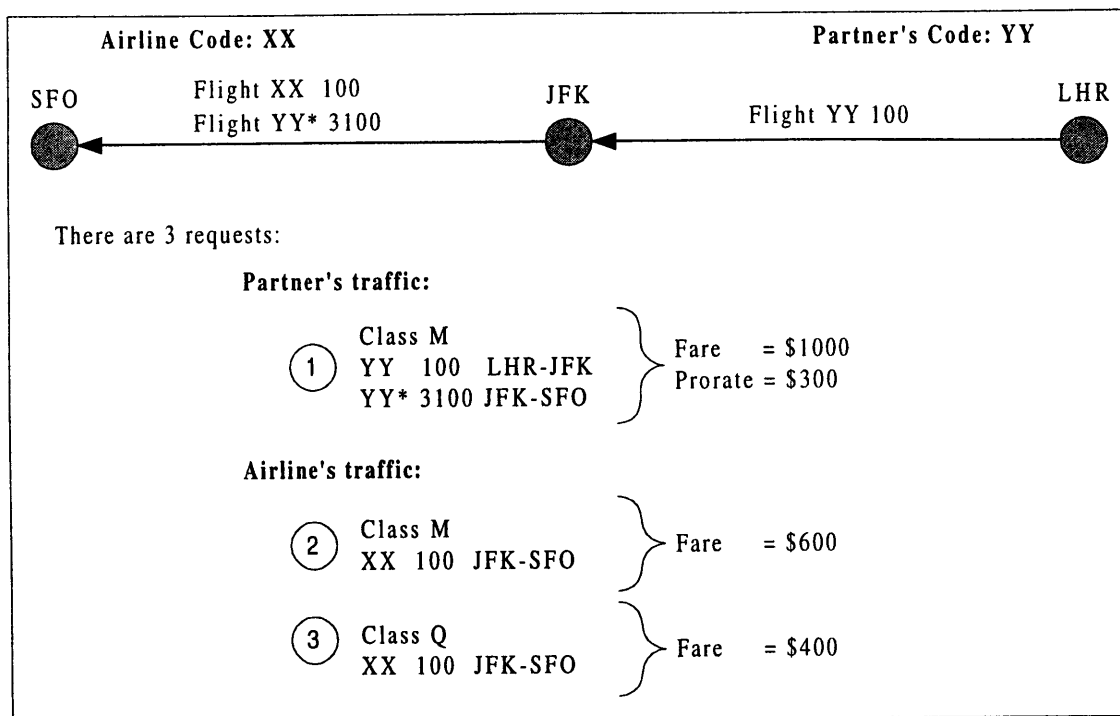

Figure 4.21. Revenue loss under airline-operated codesharing

Consider there are 3 requests for a seat in the leg XX 100 JFK-SFO, which is operated by the airline. Two of the requests are local traffic, while the third is partner connecting traffic with the leg YY* 3100 JFK-SFO as a codeshare leg corresponding to the leg XX 100 JFK-SFO. Request 1 will be given the same booking preference as request 2, since both belong to the same fare class. However, while the revenue contribution of request 2 is \$600, that of request 1 is \$300 (just the prorate). Both requests will have higher preference than request 3, of a lower fare class. Therefore, in a situation where there are only 2 seats left in the aircraft, the RMS will give the seats to requests 1 and 2, spilling the passenger of request 3. By comparing the revenue contribution of passenger 3 (\$400) and passenger 1 (\$300), it is clear that the airline is incurring a revenue loss of \$100.

4.6.2.2. Potential Modeling Solutions

As was proposed for airline-marketed codesharing, in order to solve the incorrect valuation presented above, partner-marketed codeshare traffic should be valued

accordingly to its true revenue contribution to the operating airline. For that purpose, partner requests should be valued as if it were *local traffic with a base fare equal to the prorate amount*. That is:

$$BF = PR \quad [4.5]$$

In the case of *conventional revenue management*, such base fare should be used to allocate the request to a given booking class, so that the allocation would be based on the real revenue contribution rather than the fare class. A similar procedure to that illustrated in Figure 4.16 could be employed to allocate codeshare traffic requests to booking classes. When partner requests include more than one leg operated by the airline and the proration method does not specify an amount for each codeshared leg, the O&D prorate should be split among the codeshare legs. Similarly to the way is done with non-codeshare traffic, a “prorate yield” can be used to split prorates by multiplying the prorate by the miles of each leg.

In the case of *O&D revenue management*, the network value formulation should include the prorate amount instead of the O&D fare, as presented in Equation 9.6. There, NV_P^l is the network value for leg l of codeshare traffic requesting the path P , composed of the flights in the passenger itinerary that are operated by the airline. PR_p is the total prorate amount the airline will receive from the partner for the path requested, which equals to the sum of the prorates of all the codeshare legs operated by the airline that are traversed by the itinerary flown (path P). Finally, the DC_i s are the displacement cost of all the flight-legs operated by the airline contained in the path P but leg l . Using such equation, the airline would treat partner-marketed codeshare passengers as non-codeshare airline passengers flying through paths consisting on the legs that are operated by the airline and substituting base fares by prorates in the valuation equation.

$$NV_P^l = (PR_p) - \sum_{i \in P, i \in F, i \neq l} DC_i \quad [4.6]$$

This approach to handle partner-marketed codeshare traffic might be controversial. When prorates are relatively low, partner-marketed codeshare traffic will receive low

booking priority. This goes against the philosophy of strategic alliances and might hinder a positive relationship with the partner. For example, applying the procedure explained above, the airline could end up rejecting a Y-class partner request early in the booking period. Would this be reasonable?

It seems clear that such situation would be somewhat absurd; however, if the airline provides a seat to the Y-class partner request, it might lose revenue, as shown earlier in the section. One potential solution to avoid these types of situations is to establish a limit in the number of partner-marketed bookings. At any given time in the booking period, if such bookings are less than the limit, codeshare traffic valuation can be made the same way as before, based on the fare class of requests. If the number of bookings is above the limit, then the valuation is made as proposed here. Another more obvious alternative is to rise the prorate amounts specified in the codeshare agreements.

To value partner-marketed codeshare traffic based on prorate amounts rather than base fares requires a prorate table where the RMS can look at and obtain prorates. Since prorates are in many cases defined based on the O&D of the request, the airline operating the flight should require the partner to provide path information on every booking request it makes. The same prorate table as that presented in section 4.6.1.2 could be used in this case.

4.6.3. Fully Integrated Approach

The main characteristic of the fully integrated approach is that it aims to maximize the combined revenue of the alliance. As mentioned above, the limited research carried out on airline alliance revenue management has focused on this direction. Here, an assessment of the main findings and limitations of such research will be presented.

Boyd (1998), identifies two different ways to achieve a maximization of combined revenue: Through a centralized revenue management system and through a decentralized revenue management system. On the *centralized* option, flight networks of alliance partners are treated as comprising a single network, so that forecasting,

optimization and inventory control are performed on the entire network by a centralized system. The introduction of codesharing does not bring emerging issues to seat inventory control modeling, since such process is made using the same techniques as without codesharing. Therefore, the modeling limitations and shortcomings of the centralized approach coincide with those of ordinary seat inventory control, both for conventional revenue management and O&D revenue management. The reader can refer to Belobaba (1998) for a clear exposition of such shortcomings.

However, a centralized system such as the one explained above would be extremely arduous to implement, existing multiple difficulties associated with its implementation. As explained in Section 4.5, in order to implement the fully integrated approach there must exist a fluid exchange of information and standardization of techniques among alliance partners. Coordinating flow of information from different alliance members to and from a centralized system, and having the revenue management departments of each carrier to agree on how the centralized system should be operated, are practices significantly difficult to carry out (Boyd 1998). Therefore, the decentralized option proposed by Boyd is a much more realistic alternative.

A decentralized revenue management system presents two options. First, each partner can control the entire inventory of the flights they operate. This option is very close to the centralized system. The difference is that, instead of doing inventory control on the entire network from a centralized system, each carrier operates an independent system that takes care of a share of the combined network. It is more flexible than the centralized option, allowing the use of different revenue management systems and avoiding both carriers' revenue management departments having to agree on the characteristics of the centralized system. One partner may operate conventional revenue management, while the other partner may operate O&D revenue management. Some airlines have tried this approach, since is easier to implement than the centralized one. However, the difficulties from the exchange of information are the same as with the centralized system, or even more if both carriers operate different revenue management systems. In such case, the carrier operating O&D revenue management will require

demand information at the O&D level from the partner, but the partner will only be able to provide it at the leg level. Therefore, members of an alliance undertaking this option should try to have similar seat inventory control methods; something extremely difficult to achieve in the current multi-alliance environment faced by the industry.

Ferea (1996) did research in this direction, analyzing the impacts of different revenue management strategies by each carrier. He found that there are significant interactions between the airline's revenue management systems, and that the specific characteristics of each partner's network and its revenue management system strongly affect the revenue performance. He concluded that if alliance partners use different systems, "more advanced systems spill undesirable traffic from its own network and this traffic is likely to be recaptured by the other carrier if the other carrier's revenue management system is not advanced. This traffic, however, is likely undesirable to the network as a whole and thus the strength of one carrier's system can turn into a hindrance if the other carrier's system cannot defend its part of the alliance network". Therefore, it seems clear that airlines undertaking this decentralized approach should make a significant effort to have similarly advanced revenue management systems.

Boyd (1998) proposes a *second option* for the decentralized revenue management system. He states that if some equilibrium conditions are satisfied, then the combined revenue will be maximum. Those conditions are that each carrier's expected marginal revenue from having an additional seat in their share of the inventory of a codeshare flight be the same. In other words, if carrier A and carrier B are sharing the inventory of a codeshare leg of capacity CAP , and additional seat for carrier A should be authorized always that:

$$EMSR(S_A) \geq EMSR(S_B) \quad \text{and} \quad S_A + S_B \leq CAP, \quad [4.7]$$

where $EMSR(S_A)$ is the expected marginal revenue of increasing by one seat the inventory share of airline A up to S_A seats, and $EMSR(S_B)$ is the same for airline B. In the case of conventional revenue management, EMSR is obtained through average revenue contributions obtained from the allocation of O&D fares to the legs contained

in the O&D itinerary. This allocation of fares is frequently done based on the passenger revenue generated per mile flown (the yield), so that the average leg-based fare for a given class is the average yield from all the passengers of that class traversing the leg times the miles of the leg. On the other hand, for O&D revenue management, EMSR values should be given by “pseudo fares”, which are defined as the revenue contribution of the passengers after considering their displacement impact on the network (Wei 1997). In other words, for local passengers, their pseudo fares are their entire fares, while for connecting passengers their pseudo fares on one leg are their total fares minus the displacement costs on the other legs they traverse.

In order to implement the decentralized approach proposed by Boyd, airlines would have to exchange marginal revenue functions ($EMSR(S)$), to determine optimal seat distributions among carriers. Figure 9.22 captures, as a personal interpretation by the author, the elements involved in the implementation of the decentralized seat inventory control process. The exchange of marginal revenue functions would have to be performed, at least, every time the optimization model is run to recalculate booking limits. This would imply some degree of synchronization between both carriers’ systems; something that can be extremely difficult to achieve under a multi-partner alliance environment.

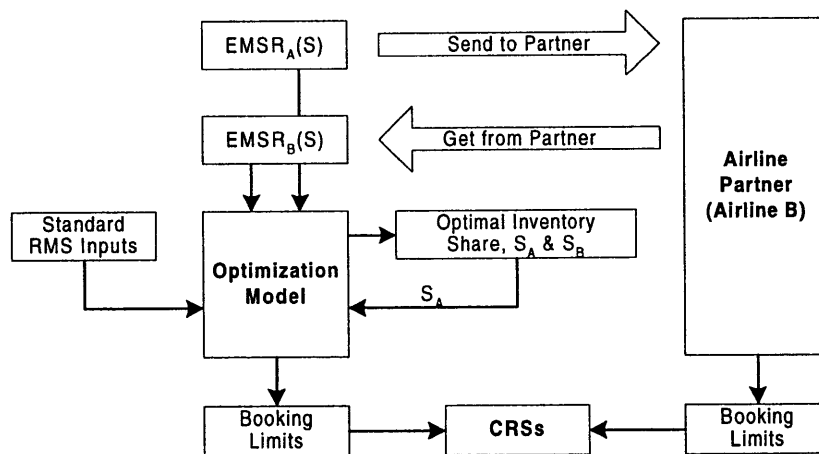

Figure 4.22. Seat Inventory control process on codeshare legs. Decentralized approach (personal interpretation from Boyd 1998)

An additional limitation of the approach proposed by Boyd arises when each carrier utilizes different revenue management systems. In the case where carrier A operates O&D revenue management and carrier B operates conventional revenue management, the marginal revenue function of airline A $EMSR_A(S)$ is measured in terms of pseudo fares, while $EMSR_B(S)$ is measured in terms of yields allocated to the legs. Therefore, the marginal revenue functions of both airlines are not comparable. Figure 4.23 illustrates this fact with an example.

Airline A and airline B are shearing the inventory of a codeshare flight. At the point in time considered, there are 5 seats remaining free in the aircraft and the demand, which is deterministic, is of 3 passengers wanting to fly through airline A's network and 3 wanting to fly through airline B's network.

There are two situations considered in the example. In the first one, named *Option 1*, airline A operates O&D revenue management, and its $EMSR(S)$ function is based on pseudo fares. The optimal sharing of the inventory is obtained by comparing the two marginal revenue functions, as shown in Equation 9.7. For this option, the optimal sharing of inventory is of 3 seats for airline A and 2 seats for airline B. However, in the second option, which is named *Option 2* and where airline A operates conventional revenue management, the optimal sharing of seats is different: 2 seats for airline A and 3 seats for airline B. In consequence, this example tells us that marginal revenue functions when partners operate different types of revenue management systems cannot be compared.

Boyd (1998) further elaborates on the potential applications of the decentralized revenue management, to include the determination of optimal block sizes for block space codesharing agreements. He states that the optimal block size for the marketing carrier, b , should be such that the expected marginal revenue functions from both airlines are as close as possible to being equal ($EMSR_A(b) \approx EMSR_B(CAP-b)$). However, this solution approach is unrealistic: Block sizes are generally specified on a city-pair basis within codesharing agreements. However, each city-pair usually contains multiple legs, and furthermore, each leg contains different departure dates. In other words, the

block sizes specified in the agreements are static and generally specified on a city-pair basis. However, the optimal block sizes obtained through equilibrium of marginal revenue functions would be different depending on the flight-leg within each city pair and the departure date of each flight. In addition, for any departure date there is a continuous change of fares over the entire booking period. Therefore, marginal revenue functions are not only a function of the departure date, but also of the time previous to departure. Nevertheless, the decentralized approach could have a potential application for block space codesharing agreements where the block size is automatically updated.

In this section, the issues concerning seat allocation algorithms for both the proration and the fully integrated approaches have been discussed. It has been confirmed that, in order to diminish implementation problems and modeling shortcomings, two carriers involved in a codesharing agreement under fully integrated approach should have similar revenue management systems. However, airlines are frequently involved in multi-partner alliances, which makes it very difficult to achieve system similarities among partners within an alliance. Consequently, proration approaches are much more common to find in practice, even though presents several shortcomings, most of them highlighted in previous sections.

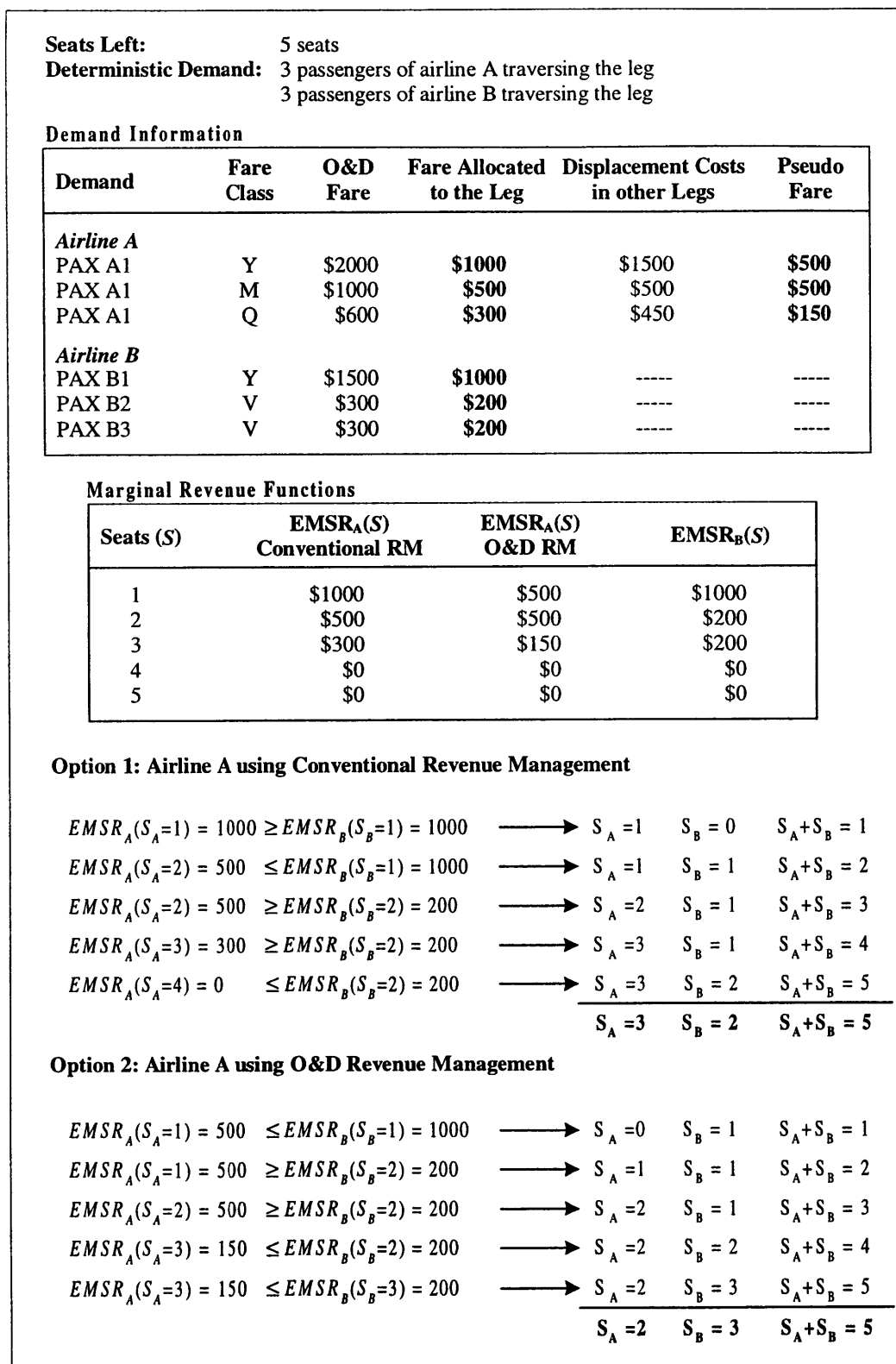

Figure 4.23. Example of decentralized revenue management on a codeshare leg. If partners use different systems, $EMSR_A(S)$ and $EMSR_B(S)$ cannot be compared

4.7. Conclusions

This chapter has covered the different problems and issues arising from the introduction of codesharing in the RMSs of today's airlines. It provides an overview of the impacts of codesharing for revenue management, and represents a guide for airline management to address the problems mentioned.

When codeshare traffic is introduced into the network of an airline, its RMS must deal with different issues, issues that can be conceptualized at two levels. At the contractual level, the economic terms of the codesharing agreement must be specified. At the operational level, RMSs and CRSs must be able to recognize codeshare traffic and treat it accordingly to such economic terms. The airline industry presents at its current state a significant diversity of approaches both to set the economic terms of the codesharing agreements and to handle codeshare traffic within RMSs. The former range from block space to free sale arrangements, while the latter range from doing nothing and treating codeshare traffic as normal traffic to implementing algorithms within RMSs to identify codeshare traffic and treat it accordingly.

Among all the different options found in the industry, two main approaches to handle codesharing within RMSs can be highlighted: The *alliance proration* approach and the *fully integrated* approach. Under the former, alliance carriers control their own inventories and optimize seat allocation without considering the partner's demand. Under the later, alliance carriers aim to perform seat inventory control based on the forecast of the combined demand in order to obtain the maximum combined revenue. Both approaches have their advantages and disadvantages for the alliance members. The fully integrated approach is more in line with the philosophy behind strategic alliances, which aim to provide a seamless service in the combined alliance network independently of the carrier operating the flights. In them, alliance partners should act together as a whole for the enhancement of the alliance, and be guided by common goals and objectives. The alliance proration approach, on the other hand, is more in line with the philosophy behind marketing alliances, where each carrier benefits from the

sharing of common activities among partners. In them, alliance partners look to themselves rather than to the alliance as whole.

The implementation of the fully integrated approach presents many complications for the airlines involved in an alliance. It requires continuous and complete communication between the partners' RMSs and CRSs. This in turn requires much more complex systems as well as standardization of RMS procedures among partners. In addition, the methods and criteria for revenue sharing become especially complicated under the fully integrated approach. Equally, the multi-partner alliance scenario faced by the airline industry today contributes to make nearly a utopia the implementation of this approach. This explains in part why most alliances both strategic and transactional that are found in the industry today undertake RMS approaches closer to the proration approach than to the fully integrated option. Nevertheless, it is expected that, as alliances mature and become more strategic and coordination among partners improves, the RMS approach to codesharing will move towards more integrated directions.

The chapter has carried out an analysis on the current limitations presented by each of the two RMS approaches to codesharing. Under the proration approach, the main shortcomings presented by the way RMS handle codesharing today are found in the valuation of codeshare traffic. Significant revenue losses might be produced by an incorrect valuation of the codeshare traffic, which arise from the displacement of non-codeshare traffic that provides higher revenue contribution to the airline. In addition, the uncertainty about the "pseudo capacity" of codeshare legs presents a potential source of revenue loss when the airline markets the traffic on flights operated by the partner (partner-operated codesharing). Under the fully integrated approach, the main shortcoming arise from the inability of partners to communicate enough information to ensure the maximization of the alliance combined revenue, and then establish "fair" and realistic revenue sharing alternatives.

A simulation carried out at a large airline showed that the most significant source of revenue loss from the current ways of handling codeshare traffic and the current prorate arrangements comes from the incorrect valuation of codeshare traffic. To solve this

problem, this chapter has addressed a potential solution. A solution that is based in the implementation on the partners' RMS of a *prorate table* where RMSs can look at and extract actual prorated information for every potential booking request. Then, an appropriate algorithm can compute a realistic measure of the revenue contribution provided by the codeshare traffic and treat it accordingly in the usual manner, as if it were non-codeshare traffic.

The solutions proposed in the chapter are based on the assumption that the economic terms of the codesharing agreement are fixed. That is, the first dimension of the problems presented by codesharing to revenue management—to set the economic terms of the agreement and monitor it—has been isolated from the second dimension—to modify RMSs and CRSs in order to identify codeshare traffic and treat it accordingly to the economic terms of the agreement. However, as was pointed out in Section 4.2, the two dimensions and the four problems they present are strongly interrelated in practice, and the issues concerning any of them depend on the issues concerning the others. Therefore, the proposed solutions presented in this chapter must be cautiously evaluated.

It is particularly important to consider the implications for the will of the alliance of changing the valuation method for codeshare traffic as proposed in the chapter. Codesharing traffic might end up providing such a low revenue contribution for the airline operating the codeshare flight that it might be rejected in most cases. This would represent a step backward in alliance spirit to integrate the partners' networks and provide a global seamless service. These problems arising from the implementation of the proposed solution were discussed in Section 4.6.1. They suggest that the proposed changes be made simultaneously with a redefinition and reevaluation of the current prorated agreements, so that the problems mentioned are overcome.

It is needed a combination of appropriate valuation methods within the proration approach with a redefinition of the revenue sharing methods (the proration methods), so that the RMS valuation algorithms applied to the new prorated levels benefit the alliance as a whole up to the maximum level. This will bring the proration approach closer to

the fully integrated approach until they meet at an ultimate state. The exploration of the different alternatives to make such things happen, which in essence constitutes the problem of transfer pricing, should be the basis of future research in this field.

Chapter 5

Conclusion

5.1. Thesis Contribution

This thesis has presented a comprehensive overview of the most critical issues faced by the current airline industry regarding the formation of airline alliances. Part I has provided several frameworks to help understand why alliances have become so critical for the participating airlines as we approach the twenty-first century. Part II has presented two of the most important problems brought by alliances and faced by airline management: the management of network connectivity and the handling of codeshare traffic by revenue management.

In **Chapter 1**, the current ambiguity found in the definition of airline alliances has been highlighted, and two definitions of the term have been presented. In a broad sense, airline alliances can be considered as any kind of agreement between independent carriers to mutually benefit from the coordination of certain activities in the provision of air transportation services. However, alliances often imply a deeper strategic connotation that requires higher commitment from the alliance partners. Therefore, a distinction between the generic term of airline alliances and the more specific term of strategic alliances has been made. Strategic airline alliances have been defined as those intercompany agreements between two or more airlines originated as a result of deliberate strategic thinking at top management level, and that, consequently, require a high degree of commitment by the alliance members in the coordination of certain activities for the achievement of an agreed set of common goals.

In addition to this first distinction, different alliance typologies have been analyzed. The most commonly used taxonomy is the one based on the scope of the alliance,

which differentiates four alliance types: Global strategic alliances, domestic strategic alliances, regional alliances, and point specific alliances. Particularly the first and the third alliance types imply a linkage of complementary networks with the objective to provide alliance customers with higher access to the markets of the world.

The main motivations for the formation of alliances have been identified. Airline alliances can be seen as a main consequence of the airline desire to increase market coverage. The formation of alliances represents in many cases the only feasible alternative to enter new markets because of the large financial costs associated with internal growth and the regulatory constraints found in international aviation for mergers and acquisitions.

In addition to the increase of market coverage, alliances provide to the participating airlines other critical sources of competitive advantage. These are fundamentally the strengthening of their market position on certain routes and the reduction of costs. These three elements contribute to the advancement of the airlines participating within the alliance; they convert alliances into strategic weapons to compete for the global skies of the twentieth century.

The evolution of the airline industry in the last quarter of the twentieth century can explain the significant growth of alliances. The formation of airline alliances can be seen as a natural evolution from simple network structures to large multi-hub networks, where major carriers have made an effort to expand their successful hub-and-spoke network schemes to the global marketplace. In fact, carriers with strong domestic networks will be the most attractive carriers for the formation of alliances.

In the last five years, the industry has witnessed a significant growth in the number of alliances. This has experienced an estimated average growth rate of 16%. Even though alliances have grown significantly, the number of equity alliances has remained approximately constant, as airlines behave more cautiously when capital investment is involved. Although there are industry signs that indicate equity will remain to be a critical factor as a way to consolidate strategic alliances, the survival rate of alliances

seems to be more dependent on the level of integration achieved than on the equity involved.

Chapter 2 has presented a comprehensive summary of the possible impacts of alliances on the airline industry and its stakeholders. The literature review and research carried out for the elaboration of this chapter have shown both *pros* and *cons* in the formation of airline alliances. Even though alliances imply some costs, it is clear that overall alliances provide significant advantages to the participating airlines, and that, therefore, represent key strategic tools to compete in the global marketplace.

The main advantages for the participating airlines within alliances are an expansion of their networks, gains in total traffic, cost savings, and the reinforcement of their market positions on certain routes. Unless alliances are not successful in achieving such goals, all that they can provide to the participating airlines are positive impacts. Otherwise, alliance members must bear the costs of the alliance without any return in exchange. Alliances will result in a failure if the expected coordination of activities is not carried out in a productive way and if cultural differences among partners raise significant tensions between organizations. To extract all the potential benefits from the formation of an alliance is not an easy task, and there is an opportunity cost associated with it.

For passengers, airline alliances can bring an increase in the level of service. The benefits passengers can obtain from airline alliances include, for example, significant gains in accessibility to foreign markets, broader frequent flyer programs, increases of frequency on certain routes, or having access to passenger lounges in all connecting airports. However, there are potential negative effects of airline alliances that can offset the benefits they provide. These negative effects are mainly represented in the possibility of alliance members to exercise market power. In such situations they can constrain service and raise prices without fear of a competitive response, and they can prevent other new carriers from entering the markets where they exercise market power.

There is no conclusive empirical evidence with respect to the negative impacts of alliances, though many studies suggest potential negative outcomes in the future. Regulators and governments have the final word in approving airline alliances and establishing conditions to maintain competition. It is clear that alliances are beneficial for the airline industry; however, governments and regulators should continue to monitor the development of airline alliances to prevent the erosion of competition.

In Part II, **Chapter 3** has analyzed the effect of the level of network connectivity within the NW/KL alliance on the gain of traffic and market share. The alliance hub-to-hub scheme has proven to be very effective in increasing the market share of the alliance when the networks of the two partner airlines are linked. In the three US airports studied, the alliance hub-to-hub link has shown a continuous increase in market share, while the rest of alliance transatlantic flights have shown a decrease or no change.

At and O&D level, the alliance's ability to capture market share has proven to be more effective over small markets (little traffic), where the level of competition is low. However, the markets that have provided to the alliance the highest levels of traffic—and therefore revenue—are in the medium-large range of sizes.

Accessibility has been developed as a measure of the alliance connectivity provided through the hub-to-hub link that incorporates the effect of several level-of-service variables. These are the connecting convenience at the hubs, the frequency, or the number of stops. Because seat-capacity is included in its definition, the measure of accessibility is also related to the availability of low fares, and therefore, to the average fare paid by customers.

A regression model has been developed to analyze the relationship between accessibility and market share. When the sample of observations is restricted to O&D market-years with reasonable levels of traffic, accessibility becomes the most significant variable and the variable that has the greatest average contribution to the market share among all the explanatory variables considered in the model. In addition, the analysis has shown that the measure of accessibility has a greater effect on the

alliance market share than frequency. Equally, the sensitivity analysis carried out has revealed that connecting flights scheduled close to the minimum connecting time as well as connecting flights scheduled far away from the departure/arrival of the hub-to-hub flight have a smaller impact on demand than the flights scheduled in-between.

The management of accessibility represents a key factor for alliances and their success in increasing their traffic shares on the markets linked by their hub-to-hub flights. Scheduling coordination and capacity management within airline alliances should therefore focus on providing high levels of accessibility through the alliance hub-to-hub links. As a result the alliance market share should increase.

There are two basic ways in which airline alliances can achieve high levels of accessibility: By adding capacity to the hub-to-hub links or the connecting routes, and by adjusting the schedules of connecting flights in order to increase their connecting convenience—and therefore the accessibility provided. The first option is the most expensive one, although should also be the most effective in increasing market share. The addition of more flights increases frequency, and the addition of more seats increases availability of low fare classes—decreasing, therefore, the average fare paid by customers. Both frequency and availability of low-fare classes are two key drivers of demand.

In the second option, it is difficult to know what the “optimal” time window for the scheduling of connecting flights should be, since accessibility has been arbitrarily defined based on logical assumptions. However, the results of the sensitivity analysis have indicated that connecting flights scheduled within 1:30 and 3:30 hours from/to the hub-to-hub flight arrival/departure should have the greatest impact on demand. Although we must be cautious when evaluating these results, they can be taken as a reference for scheduling planning.

Chapter 4 provides an overview of the different problems and issues arising from the introduction of codesharing into the revenue management systems (RMSs) of today’s airlines.

When codeshare traffic is introduced into the network of an airline, its RMS must deal with different issues, issues that can be conceptualized at two levels. At the contractual level, the economic terms of the codesharing agreement must be specified. At the operational level, RMSs and CRSs must be able to recognize codeshare traffic and treat it accordingly to such economic terms. The airline industry presents at its current state a significant diversity of approaches both to set the economic terms of the codesharing agreements and to handle codeshare traffic within RMSs.

Among all the different options found in the industry to handle codesharing within RMSs, two main approaches can be highlighted: The alliance proration approach and the fully integrated approach. Under the former, alliance carriers control their own inventories and optimize seat allocation without considering the partner's demand. Under the later, alliance carriers aim to perform seat inventory control based on the forecast of the combined demand in order to obtain the maximum combined revenue. Both approaches have their advantages and disadvantages for the alliance members.

The implementation of the fully integrated approach presents many complications for the airlines involved in an alliance. It requires continuous and complete communication between the partners' RMSs and CRSs. This in turn requires more complex systems as well as a standardization of RMS procedures among partners. In addition, the methods and criteria for revenue sharing become especially complicated under the fully integrated approach. Equally, the multi-partner alliance scenario faced by the airline industry today contributes to make nearly a utopia the implementation of this approach. This explains in part why most alliances today undertake RMS approaches closer to the proration approach than to the fully integrated option. Nevertheless, it is expected that, as alliances mature and become more strategic and coordination among partners improves, the RMS approach to codesharing will move towards more integrated directions.

An analysis was carried out on the current limitations presented by each of the two RMS approaches to codesharing. Under the proration approach, the main shortcomings are in the valuation of codeshare traffic. Significant revenue losses might be produced

by an incorrect valuation of the codeshare traffic, which arise fundamentally from the displacement of non-codeshare traffic that, however, provides higher revenue contribution to the airline. In addition, the uncertainty about the “pseudo capacity” of codeshare legs presents a potential source of revenue loss when the airline markets the traffic on flights operated by the partner (partner-operated codesharing). Under the fully integrated approach, the main shortcomings arise from the inability of partners to communicate enough information to ensure the maximization of the alliance combined revenue, as well as from the inability to establish “fair” revenue sharing alternatives.

A simulation carried out previously at a large airline showed that the most significant source of revenue loss from the current ways of handling codeshare traffic under the proration approach comes from the incorrect valuation of codeshare traffic. To solve this problem, this chapter has proposed a potential solution. A solution that is based on the implementation of a *prorate table* on the partners’ RMSs where they can look at and extract actual prorate information for every potential booking request. Then, an appropriate algorithm can compute the true revenue contribution provided by the codeshare traffic and treat it accordingly in the usual manner.

The solutions proposed in the chapter are based on the assumption that the economic terms of the codesharing agreement are fixed. That is, they are proposed as if the first dimension of the problems presented by codesharing to revenue management—to set the economic terms of the agreement and monitor it—were isolated from the second dimension—to modify RMSs and CRSs in order to identify codeshare traffic and treat it accordingly to the economic terms of the agreement. However, as was pointed out in Chapter 4, the two dimensions and the four problems associated with them are strongly interrelated in practice, and the issues concerning any of them depend on the issues concerning the others. Therefore, one must be cautious when evaluating the proposed solutions presented in this chapter. A final answer to the incorrect valuation problem should include a redefinition of the prorate agreements.

5.2. Further Research

Accessibility, the measure developed in this thesis for measuring network connectivity, does not take into account the effect of other additional variables, such as airfares, quality of passenger service, or the LOS offered by competing carriers. The thesis has focused on providing the basis of a framework that explains network connectivity as a main driver of demand in the alliance scenario of today's industry. Further research should incorporate into the model the effect of additional variables, and evaluate their impact. In particular, it would be useful to incorporate the effect of variables accounting for the time-of-day at which arrivals and departures of connecting flights are scheduled.

The models for accessibility has been developed for a hub-to-hub network scheme; however, it could be generalized to any network based on a hub-and-spoke scheme. For example, it could be extended to the US domestic networks. In this case, the accessibility parameters and weight functions should be different, and other transportation LOS variables should gain importance.

In the evaluation of the potential solutions to approach the handling of codesharing within RMSs, it is particularly important to consider the implications for the will of the alliance to change the valuation method for codeshare traffic as proposed in this thesis. Codesharing traffic might end up providing such a low revenue contribution for the airline operating the codeshare flight that it might be rejected in most cases under the new valuation scheme. This would represent a step backward in the alliance spirit to integrate the partners' networks and provide a global seamless service. The problems arising from the implementation of the proposed solution suggest that the proposed changes be made simultaneously with a redefinition and reevaluation of the current prorate agreements, so that the problems mentioned are overcome.

Therefore, it is needed both an appropriate valuation of codeshare traffic by looking at its real revenue contribution and a redefinition of the revenue sharing methods, so that the RMS valuation algorithms applied to the new prorate levels benefit the alliance as a whole up to the maximum level. This will bring the proration approach closer to the

fully integrated approach until they meet at an ultimate state. The exploration of the different alternatives to reach such goal—that, in essence, constitutes the problem of transfer pricing—should be the basis of future research in this field.

This thesis has presented just two of the challenges faced by airline management in the alliance scenario of today's industry; however, as alliances mature and evolve towards higher integration among alliance partners, additional problems are expected to raise. To handle the operational complexity and cross-cultural environment brought by the new alliance environment in an effective manner represents a real challenge for airline management in the twenty-first century. This thesis should be viewed as a mere introduction to all that is to come. The research carried out aims to bring light to an area that as today is diffuse, but which faces a significant need of solutions. It represents a guide and a starting point for future research.

References

- Belobaba, P. P. (1987): *Air Travel Demand and Airline Seat Inventory Management*, Ph.D. dissertation, Massachusetts Institute of Technology, Cambridge, MA, May 1987.
- (1992): “Optimal vs. Heuristic Methods for Nested Seat Allocation,” Presentation to AGIFORS Yield Management Study Group, Brussels, May 1992.
- (1995): “Airline O-D Seat Inventory Control without Network Optimization,” Massachusetts Institute of Technology, Cambridge, MA, June 1995.
- (1998): “The Evolution of Airline Yield Management: Fare Class to Origin-Destination Seat Inventory Control,” *The Handbook of Airline Marketing*, McGraw Hill, New York, 1998.
- Borenstein, S. (1990): “Airline Mergers, airport dominance and market power,” *American Economic Review*, vol. LXXX, May, pp. 400-04.
- Boyd, E. A. (1998): “Airline Alliance Revenue Management,” *MSOR Today*, August 1998, pp. 28-31.
- Bratu, E. (1998): *Network Value Concept in Airline Revenue Management*, MS Thesis, Massachusetts Institute of Technology, Cambridge, MA, June 1998.
- Button, K. (1997): *Interactions of Global Competition, Airline Strategic Alliances and Air Traffic Safety*, International Aviation Safety Conference, Rotterdam, August 1997.
- Caves, D. W., Christensen, L. R., and Tretheway, M. W. (1984): “Economies of Density Versus Economies of Scale: Why Trunk and Local Service Airline Costs Differ,” *The Rand Journal of Economics*, vol. 15(4), pp. 471-489.
- Clugherty, J. A. (1998): *US Domestic-Airline-Alliances: Do Strategic International Gains Outweigh Domestic Consumer Losses?*, Working Paper, Tilburg University, the Netherlands
- Curry, R. E. (1990): “Optimum Seat Allocation with Fare Classes Nested by Origins and Destinations,” *Transportation Science*, vol. 24, pg. 193-204.
- Debbage, K. (1994): “The International Airline Industry: Globalization, Regulation and Strategic Alliances,” *Journal of Transport Geography*, vol. 2(3), pp. 190-203.
- Eccles, R. G. (1983): “Control with Fairness in Transfer Pricing,” *Harvard Business Review*, November-December.
- Ferea, J. D. (1996): *Revenue Management Impacts of Multiple-Hub Codeshare Alliances*, MS thesis, Massachusetts Institute of Technology, Cambridge, MA, June 1996.

- Freidheim, C. (1998): *The Trillion-Dollar Enterprise: How the Alliance Revolution Will Transform Global Business*, Perseus Books, HarperCollins Publishers, New York.
- General Accounting Office (GAO) (1995): *Airline Alliances Produce Benefits, but Effect on Competition is Uncertain*, GAO/RCED-95-99, April, Washington
- (1998a): *International Aviation Alliances and the Influence of Airline Marketing Practices*, GAO/T-RCED-98-131, March, Washington.
- (1998b): *Proposed Domestic Alliances Rise Serious Issues*, GAO/T-RCED-98-215, June, Washington.
- (1999): *Effects on Consumers from Domestic Airline Alliances Vary*, GAO/RCED-99-37, January, Washington.
- Gellman Research Associates, Inc. (GRA) (1993): “Airline Strategic Alliances: Definition and a Case for Caution,” *Transportation Advisor*, vol. 3(1), January.
- (1994): *A Study of International Code Sharing*, Report submitted to the Office of Aviation and International Economics, DOT, Washington, December.
- Hadrovic, C. (1990): “Airline Globalization: A Canadian Perspective,” *Transportation Law Journal*, vol. 19(1), pp. 193-217.
- IATA (1998): *Airline Prorate Manual*, publication of the Prorate Agency, Geneva, Switzerland, March 1998.
- Industry Commission of Australia (ICA) (1997): *The Economic Impact of International Airline Alliances*, Melbourne.
- Oster, S. M. (1994): *Modern Competitive Analysis*, Second Edition, Oxford University Press, New York
- Oster, C.V., and Pickrell D. H. (1988): “Codesharing, Joint Fares, and Competition in the Regional Airline Industry,” *Transportation Research*, vol. 22A(6), pp. 405-417.
- Oum, T. H., Taylor, A. J., and Zhang, A. (1993): “Strategic Airline Policy in the Globalizing Airline Industry,” *Transportation Journal*, vol. 32(3) (Spring), pp. 14-30.
- Oum, T. H., and Park, J. H. (1997): “Airline Alliances: Current Status, Policy Issues, and Future Directions,” *Journal of Air Transport Management*, vol. 3(3), pp. 133-144, July.
- Oum, T. H., Park, J. H., and Zhang, A. (1996): “The effects of Airline Codesharing Agreements on Firm Conduct and International Air Fares,” *Journal of Transport Economics and Policy*, vol. 30(2), May, pp. 187-202.
- Park, J. H. (1997): *Strategic Airline Alliance: Modeling and Empirical Analysis*, Ph.D. dissertation, The University of British Columbia, British Columbia, Canada.

- Parkhe, A. (1993): "Strategic Alliance Structuring: A Game Theoretic and Transaction Cost Examination of Interfirm Cooperation," *Academy of Management Journal*, vol. 36(4), pg. 794-829.
- Phillips, E. (1997): "Joint Purchasing Pursued by Alliances," *Aviation Week and space Technology*, November 17, pp. 65-68.
- Rhoades, D. L., and Lush, H. (1997): "A typology of Strategic Alliances in the Airline Industry: Propositions for Stability and Duration," *Journal of Air Transport Management*, vol. 3(3), pp. 109-114, July.
- Shaw, S. L., and Ivy, R. (1994): "Airline Mergers and their Effect on Network Structure," *Journal of Transport Geography*, vol. 2(4), pp. 234-246.
- Shifrin, C. (1997): "Proliferating Partnerships Face Increased Scrutiny," *Aviation Week and space Technology*, November 17, pp. 61-62.
- Smith, B. (1997): "CRS Promise Added Benefits For Aggressive Alliances," *Aviation Week and space Technology*, November 17, pp. 63-65.
- The Economist (1997): "Let the market take-off", January 18, pp. 82.
- Smith, B. C., Leimkuhler, J. F., and Darrow, R. M. (1992): "Yield Management at American Airlines," *Interfaces* 22, pp. 8-31.
- Sparaco, P. and Ott, J. (1997): "Unique Industry Facets Shape Europe's Alliances," *Aviation Week and space Technology*, November 17, pp. 54-56.
- Simons, M. (1997): "Aviation alliances - Implications for the Qantas-BA alliance in the Asia Pacific Region," *Journal of Air Law and Commerce*, vol. 62(3), pp. 841-867.
- The Economist (1997): "Let the market take-off," January 18, pp. 82.
- Thurow, L. (1996): *The Future of Capitalism: How Today's Economic Forces will Shape Tomorrow's Future*, William Morrow, New York, 1996.
- Weatherford, L. R., and Bodily, S. E. (1992): "A Taxonomy and Research Overview of Perishable-Asset Revenue Management: Yield Management, Overbooking and Pricing," *Operations Research*, vol. 40, pp. 831-844.
- Wei, Y. (1997): *Airline O-D Control Using Network Displacement Concepts*, MS Thesis, Massachusetts Institute of Technology, Cambridge, MA, May 1997.
- White, L. (1979): "Economies of Scale and the Question of 'Natural Monopoly' in the Airline Industry," *Journal of Air Law and Commerce*, vol. 44(3), pp. 545-573.
- Williamson, E. L. (1988): *Comparison of Optimization Techniques for Origin-Destination Seat Inventory Control*, MS thesis, Massachusetts Institute of Technology, Cambridge, MA, June 1988.
- (1992): *Airline Network Seat Inventory Control: Methodologies and Revenue Impacts*, Ph.D. dissertation, Massachusetts Institute of Technology, Cambridge, MA, June 1992.

- Wynne, R (1998): "From Queen Airs to RJs: Evolution in Major-Regional Airline Alliances and Code Sharing," *The Handbook of Airline Economics*, Mc Graw Hill, New York.
- Yoshino, M.Y., and Rangan, U. S. (1995): *Strategic Alliances—An Entrepreneurial Approach to Globalization*, Harvard Business School Press, Cambridge, Massachusetts.
- Youssef, W. A. (1992): *Causes and Effects of International Equity Alliances*, Ph.D Dissertation, Institute of Transportation Studies, University of California, Berkeley, California.
- Zea, M., and Feldman, D. (1998): "Going Global: The Risks and Rewards of Airline Alliance-Based Network Strategies," *The Handbook of Airline Economics*, Mc Graw-Hill, New York