

**GROUND FACILITIES
FOR A VTOL INTERCITY AIR
TRANSPORTATION SYSTEM**

**Edward Allen
Robert W. Simpson**

MIT

**DEPARTMENT
OF
AERONAUTICS
&
ASTRONAUTICS**

**FLIGHT TRANSPORTATION
LABORATORY
Cambridge, Mass. 02139**

May 1970

FTL Report R69-2

GROUND FACILITIES FOR A VTOL
INTERCITY AIR TRANSPORTATION SYSTEM

Edward Allen, Assistant Professor
of Architecture, M.I.T.

Robert W. Simpson, Associate Professor
of Aeronautics and Astronautics, M.I.T.

FTL Report R69-2

May 1970

TABLE OF CONTENTS

<u>Page</u>	<u>Chapter</u>	<u>Title</u>
vi		Summary of Primary Conclusions
1	I	<u>Introduction</u>
1		A. The VTOL Airbus System
3		B. Purpose of the Report
4		C. History of the Study
5		D. Descriptions of the Report
6	II	<u>The Siting of VTOL Metroports</u>
6		A. Accessibility Factors
8		B. Airspace Factors
11		C. Environmental Factors
13		D. Groundspace Factors
17		E. The Site Selection Process
20	III	<u>General Design Considerations for VTOL Metroports</u>
20		A. General Design Factors
20		A.1 Minimum Walking Distance
22		A.2 Space and Capacity Criteria
23		A.3 Modular Construction of VTOL Metroports
26		A.4 Design Standards
27		B. Previous Work in VTOL Terminal Design
30		C. Flight Deck Configuration Studies
35	IV	<u>The Design Components for VTOL Metroports</u>
35		A. Passenger Information Systems
37		B. Automated Passenger Processing System
42		C. In-Terminal Passenger Flow Paths
46		D. In-Aircraft Passenger Flows
51		E. Baggage Loading and Unloading
54		F. The Flight Deck System
62		G. Parking Accommodations
64		H. Access Roadways
66	V	<u>Ten Evolving Studies in Metroport Design</u>
67		A. Study #1: Boston Vertiport, January 1969
81		B. Study #2: The Drive-Through Scheme
88		C. Study #3: The Moving Sidewalk Scheme, December 1969

TABLE OF CONTENTS (Continued)

<u>Page</u>	<u>Chapter</u>	<u>Title</u>
(CHAPTER V Continued):		
92	D.	Study #4: The Elevator Lounge Scheme, July 1969
98	E.	Study #5: The Skywalk Scheme, August 1969
103	F.	Study #6: The Suburban Scheme, October 1969
109	G.	Study #7: The Central Scheme, November 1969
114	H.	Study #8: The Split Level Scheme, December 1969
123	I.	Study #9: The Suburban Split Level Scheme
123	J.	Study #10: The Folded Wing Scheme, December 1969
129	K.	Conclusions
130		Appendix: Metroport Construction Costs
133		Bibliography and References

LIST OF FIGURES

<u>Page</u>	<u>Figure</u>	<u>Caption</u>
15	II.1	Site Acreage for Metroports
15	II.2	Ratio of STOL/VTOL Site Acreage
31	III.1	Possible Metroport Flight Deck Configurations
32	III.2	Three Possible Relationships Between Automobile Access and Passenger Flow in a Linear Metroport
38	IV.1	Passenger Functional Flow Diagram
39	IV.2	Automatic Check-in Consoles
43	IV.3	Devices for Boarding Passengers from Below Flight Deck
45	IV.4	Plan Views of Vehicle Loading and Unloading Flow Patterns
47	IV.5	Cross Section of Proposed Cabin Design
48	IV.6	Longitudinal Section of Proposed Cabin Design
53	IV.7	Baggage Loading and Unloading Flow Patterns
55	IV.8	The Flight Deck Structure
70	V.A.1	Location for Boston Vertiport
71	V.A.2	View on 15° Approach to Boston Vertiport
72	V.A.3	Cross-Section of Boston Vertiport
73	V.A.4	Plan View- Vehicular Arrival & Departure Level
74	V.A.5	Plan View - Passenger Concourse Level
75	V.A.6	Plan View - Passenger Mezzanine Level
76	V.A.7	Plan View - Inside Deck Level
77	V.A.8	Plan View - Deck Level
78	V.A.9	Longitudinal Cross Section - Boston Vertiport
83	V.B.1	Graphic Symbols for Drawings
84	V.B.2	The Drive Through Scheme: Floor Plan Levels 1 and 2
85	V.B.3	The Drive Through Scheme: Floor Plan Level 3
86	V.B.4	The Drive Through Scheme: Cross Section
90	V.C.1	The Moving Sidewalk Scheme: Main Floor Plan
91	V.C.2	The Moving Sidewalk Scheme: Cross, Longitudinal Sections
94	V.D.1	The Elevator Lounge Scheme: Main Floor Plan
95	V.D.2	The Elevator Lounge Scheme: Plan, Upper Level
96	V.D.3	The Elevator Lounge Scheme: Cross Sections

LIST OF FIGURES (Continued)

<u>Page</u>	<u>Figure</u>	<u>Caption</u>
99	V.E.1	The Skywalk Scheme: Main Floor Plan
100	V.E.2	The Skywalk Scheme: Plan, Upper Level
101	V.E.3	The Skywalk Scheme: Cross Sections
105	V.F.1	The Suburban Scheme: Aerial View
106	V.F.2	The Suburban Scheme: Floor Plan
107	V.F.3	The Suburban Scheme: Cross Sections
111	V.G.1	The Central Scheme: Aerial View
112	V.G.2	The Central Scheme: Floor Plans
113	V.G.3	The Central Scheme: Deck Plan, Cross Section
117	V.H.1	The Split Level Scheme: Aerial View
118	V.H.2	The Split Level Scheme: Levels 1 and 2
119	V.H.3	The Split Level Scheme: Floor Plans
120	V.H.4	The Split Level Scheme: Cross Sections
121	V.H.5	The Split Level Scheme: Perspective
126	V.J.1	The Folded Wing Scheme: Aerial View
127	V.J.2	The Folded Wing Scheme: Floor Plans
128	V.J.3	The Folded Wing Scheme: Cross Sections

SUMMARY OF PRIMARY CONCLUSIONS

1. Appropriate governmental agencies should develop firm guidelines for the location, design, and operation of VTOL ground facilities, in order to assure safe and efficient operation, to minimize undesirable environmental side effects, and to provide for the orderly, problem-free growth of the VTOL system over the coming decades.
2. VTOL metroports and their associated flight paths can and should be located in and over already-noisy areas, remote from areas of human occupancy.
3. A VTOL terminal building of a given passenger-handling capacity can be made more compact and convenient than any STOL or CTOL terminal building of comparable capacity. Available curbspace for taxis and automobiles appears to be a prime factor limiting the compactness which can be achieved.
4. In terms of minimum trip times and maximum utilization of aircraft and terminal buildings, it is more efficient to have passengers walk to the aircraft than to move

the aircraft to the passengers. This can be accomplished in a terminal which entails walking distances approaching an absolute minimum while still maintaining reasonable economy in utilization of land.

5. State-of-the-art hardware and software can be used to create rapid, simple self-service ticket and baggage systems which will contribute significantly to the overall efficiency and economy of the VTOL system.
6. Significant reductions in passenger loading and unloading times should be possible through use of aircraft cabin configurations designed specifically for VTOL short-haul intercity service.
7. The VTOL flight deck, together with its associated mechanical services, is of such importance to smooth, safe, reliable VTOL operations that its design should become the subject of intensive research and development. The design ultimately adopted should be made mandatory for all VTOL airports, in a fashion similar to the establishment of standard runway dimensions, lighting, etc.
8. Except for certain specialized components, including parts of the flight deck and a number of items of terminal equipment, there is likely to be little economy in centralized factory fabrication of VTOL metroport buildings.

CHAPTER I

INTRODUCTION

A. The VTOL Airbus System

This study covers the design of ground facilities, or metroports, for a future form of short haul intercity air transportation, the VTOL Airbus system as described by previous M.I.T. Flight Transportation Laboratory reports. This system will use VTOL aircraft, such as compound helicopters or tilt wings, which will operate from metroports sited throughout a metropolitan region, and will provide frequent service between the regions which make up an urban corridor, or megalopolis. The metroports are conceived as relatively compact installations placed in city center areas and at major roadway junctions throughout the surrounding suburban region.

By providing shorter access and egress times for short haul passengers, and by avoiding airport taxi times and delays due to congestion, the Airbus service will offer substantially improved megalopolitan travel times at total costs comparable to those of the present air system.

The service will be all weather, night and day, using its own airspace at the metroports, and a segregated airspace when the metroport is co-located with an airport. The trip lengths will vary between 30-300 miles, which would include travel generated by business commuters in the corridor region, and the travel arising from collecting and distributing the long haul air passenger to and from the major airports in the corridor.

Previous systems engineering studies discovered that the ground facilities for such a VTOL system are easily the most important component. The usual predominance of the design and operation of the air vehicle did not hold for this new system, since the ground operations costs were **projected** to be much higher, and at least twice as much investment was expected to be required for new ground facilities as for new vehicles. Additionally, the time savings offered by the system were far more sensitive to the number and distribution of metroports than to vehicle speed.

B. Purpose of the Report

This report is an attempt to go more deeply into the problems of designing, operating, and locating the ground facilities for such a system. It is necessarily done in the abstract, although at the level of analysis of this report this presents few difficulties. These problems have not been studied previously to the same extent as the vehicle design and operating problems, and as a consequence many of the conclusions, ideas, and results of this report may still be termed provisional or preliminary. It was felt that it would be important to air transportation planners to do this exploratory work in order to show the many considerations which arise, and to discover areas where future research, development, and operating experience are required.

The purposes of the study were manyfold. They may be described as follows:

1. To explore the problems of design and operation of the ground components of the VTOL air system.
2. To establish preliminary guidelines for the design of future metroports.

3. To see if a common design for terminal buildings could be found, or to establish the degree of commonality which exists.
4. To estimate the size and construction costs of the metroports.
5. To establish sitting criteria.

A companion report, also in preparation, will deal with a simulation of passenger operations in a terminal building.

C. History of the Study

This study was begun by the Departments of Architecture and Aeronautics & Astronautics in the Fall of 1967 at the suggestion of Professors Rene Miller and Robert Simpson. Early explorations were made by Nicholas Grimshaw of the M.I.T. Department of Architecture. Since January of 1968 the work has proceeded under the direction of Edward Allen, Assistant Professor of Architecture at M.I.T. Graduate research assistants in the Department of Architecture have included John Davidson, Dimitri Stamatiadis, and Robert Turano. William Lange, John Lindley and R. Dixon Speas, Jr., all of the M.I.T. Flight Transportation Laboratory, have also assisted in the research. Two architectural design classes involving about 20 students in all have

also participated in the project. Financial support has been furnished by a grant from the M.I.T. School of Architecture and Planning, a grant from the M.I.T. Urban Systems Laboratory, and by funding under contract C-85-65 from the Northeast Corridor Transportation Project, Office of High Speed Ground Transport, Department of Transportation.

D. Description of the Report

The problems of locating a metroport site in a typical urban area is discussed in Chapter II. A general discussion of metroport terminal building design considerations is given in Chapter III, and a description of some of the functional components of the terminal is provided in Chapter IV. A selection of some of the designs developed during the course of the study is described in Chapter V. It was decided to present a number of the metroport designs in chronological order to show the problems encountered and the progression of our thinking, and to provide some breadth of background to a reader who may become involved in the problems of designing and building a VTOL Airbus system.

CHAPTER II

THE SITING OF VTOL METROPORTS

The problems of locating a set of new air transportation terminals in an urban community are discussed in this section under the following headings: Accessibility Factors, Airspace Factors, Environmental Factors, and Groundspace Factors. A process for site selection in a community is then discussed, including planning and political factors.

A. Accessibility Factors

To provide good access, planning for metroports should consider plans for urban transportation developments. The junctures of expressways and transit lines are desirable points for terminals. Since the roadway system will probably be the dominant form of access for the short haul traveler using taxi and private auto, it is particularly important to choose sites which provide good road access. This suggests expressway locations, and preferably locations over expressway interchanges. Construction at such sites would require an elevated structure above the roadways, and a system of elevated access road links into the terminal.

Urban transit systems, present or planned, should be considered whenever a transit station might be included as part of the terminal. Railroad stations already existing in the cities can provide a location where rail, transit and roadway already meet, and local rail yards provide the clear air and groundspace for a possible metroport site.

Such locations lead to the concept of a transportation center as an interchange point between multiple modes. The full development of this concept has a center located over an expressway junction with a transit terminal below ground, a bus terminal, with curb operations for taxi delivery and pickup on the first level, some elevated levels for parking, and a metroport terminal on the top level. Vertical connections in the building would be made by elevators, and escalators.

Such a concentration of transportation activity would only be justified at city center locations. The probable usage of a VTOL metroflight system would require a number of sites to be located within the complete metropolitan region. For good accessibility, a pattern of sites should be established relative to the pattern of trip generation expected from the metropolitan region for suburban areas. Expressway interchanges, industrial parks, secondary airports, and swamp or hillside areas suggest themselves as suitable locations.

While it is theoretically possible to plan a set of sites to optimize accessibility to the system, one must have information on trip originations and destina-

tions for the metroflight traveller and the associated volumes of travel from these points. This data is scarce even for today's airline traveller, and methods of predicting local travel generation depend on knowing population densities, levels of income, areas of high commercial activity, and areas of overnight accomodation for non-residential travellers. A metroport will in the long term attract these last two activities to the surrounding area, which makes forecasting difficult. Also, the trip generation volumes will be a function of the levels of metroflight service offered at the various sites. The result of these complications is that it is impossible to find with any confidence a pattern of sites which minimizes overall access times for the traveller. The general rules should be to space metroports throughout the community at sites which have good ground transportation accessibility. The impact on the community will ensure a good balance of trips in the local area in subsequent years, as urban development minimizes its access to the system.

B. Airspace Factors

For a proposed site, there are two factors in the

airspace which must be examined: obstruction clearance, and the airspace traffic patterns for local airports.

Requirements for obstruction clearances for VTOL metroports are not yet established. They will be determined by the navigation and guidance capabilities for the VTOL aircraft. Formal approach and departure paths to the site would likely be established which pass over built up areas, and may pass by tall buildings. In the final stages of approach, it will be preferable to have a clear zone such as a railyard, swamp, or waterfront below the approach path. For the waterfront area, shipping will present the possibility of occasional mast heights up to 100 feet above water level. The clear zone requirements may be overcome by using an elevated deck such that there are no obstacles in the zone at the level of the deck. Thus the metroport deck level is placed above shipping, and surrounding buildings in order to provide obstruction clearance around the site. Yet taller buildings in the area will restrict the approach and departure paths, and criteria on the nearness of approach will have to be established as a function of system navigation and guidance capabilities.

Airspace patterns for local airports will create

traffic problems for metroport sites, and the approach and departure routings must be made compatible with existing or future CTOL traffic patterns. Locations which otherwise are completely desirable may be infeasible simply because of their location relative to busy CTOL airports under the ATC procedures presently used. However, a study of possible changes in the present procedures and any changes which might result from new ATC developments is warranted before declaring the site infeasible.

In this report it is assumed that IFR bad weather operations will be carried out by the VTOL metroflight system. A new form of all weather landing system will have to be provided for the metroport giving accurate guidance along a few final approach paths. For the VTOL aircraft, it is assumed that a guidance and stabilization system will be installed to permit manual or automatic blind approaches to a hover point 50 feet above the landing deck. Then the aircraft would air taxi to its assigned gate. Departures will rise vertically off the pad and air taxi or fly directly into a departure path. These local deck maneuvers would be under control

of a metroport control tower.

C. Environmental Factors

At certain desirable sites, the problems generated by noise levels imposed on the surrounding areas by arriving and departing aircraft can be severe enough to block community acceptance of a metroport. It appears necessary to plan the approach and departure paths very carefully to minimize noise intrusions; steep angles of climb and descent, curved or irregular paths into the site, time of day variations in procedures, etc., all should be demonstrated to the local community and its political leaders. There will likely be new forms of noise standards established at each site covering every arrival and departure path, and VTOL aircraft will probably have to demonstrate locally before being approved for the site. This places economic pressures on the manufacturer and operator to produce quieter vehicles, and means that the criteria for measurement of noise, and establishment of acceptable levels become crucial issues to metroflight service.

The criteria for establishing noise pollution levels

require further study and development. Certainly, background noise levels in the surrounding area should be a factor. The number of listeners and their insulation from the noise should also be considered. Sites can be found in industrial parks where all the surrounding working populace is enclosed in sealed, relatively sound-tight air conditioned buildings. Acceptable external noise levels at such a site will be much higher than those of a suburban site with a nearby community with its populace out of doors in streets and backyards. The duration of the noise, and the cumulative effect throughout the day, are still further factors in determining noise standards for the metroport site.

These factors indicate the need for developing a new noise pollution criterion which has dimensions of (noise level above background perceived by listener) x (number of listeners) x (cumulative time of exposure), or Pndb-people-seconds. The metroflight system planners and operators working within such a criterion established by the local community would have the flexibility of meeting it by lowering aircraft noise levels, limiting the number of aircraft operations, or insulating or removing

people from the areas where noise is imposed on surrounding areas. The establishment of an acceptable daily value for this criterion is equivalent to present pollution criteria which restrict the amounts of pollutant which can be released in a given period. It is perhaps a rather practical engineering approach to the problem, but some criterion of this nature should be adopted to provide a mechanism for political leaders to work with in obtaining community acceptance of metroports.

For a busy urban metroport there will be a concentration of exhaust gases in the neighborhood of the landing deck. While it is not expected that future engines will emit much visible exhaust pollution, a problem may arise from the characteristic smells from turbine engines if the prevailing wind blows fumes from the landing deck area into surrounding areas. While an elevated deck may help in keeping exhaust gases above the surrounding buildings, the main method of avoiding this problem is in selection of the site.

D. Groundspace Factors

As mentioned under accessibility factors, sites for

metroports exist in waterfront areas, expressway inter-sections, railyards, tops of buildings, secondary airports, swamps, hillside areas, etc. A surprising number of them involve air rights and construction of an elevated structure for operations, which causes increased foundation costs.

Every available site in an urban area will have a restricted acreage associated with it caused by rivers, roadways, nearby development which cannot be expropriated, etc. From viewing maps and aerial photos of cities in the corridor, it is observed that the number of available sites decreases rapidly as the required acreage increases. The requirements for groundspace are specified by the expected volume of traffic at the site which in turn determines the number of gates or landing pads needed.

The relationship of site acreage with number of pads for the VTOL metroports of this report is shown in Figure II.1.

Pad sizes have been assumed as 150 foot squares, so that each pad is roughly $\frac{1}{2}$ acre. In this report, the total metroport is roughly twice this size, so that we average 1 acre per pad or loading gate. Any additional acreage for access roadways, clear zones or additional parking is not included in figure II.1.

Figure II-1 SITE ACREAGE FOR METROPORTS

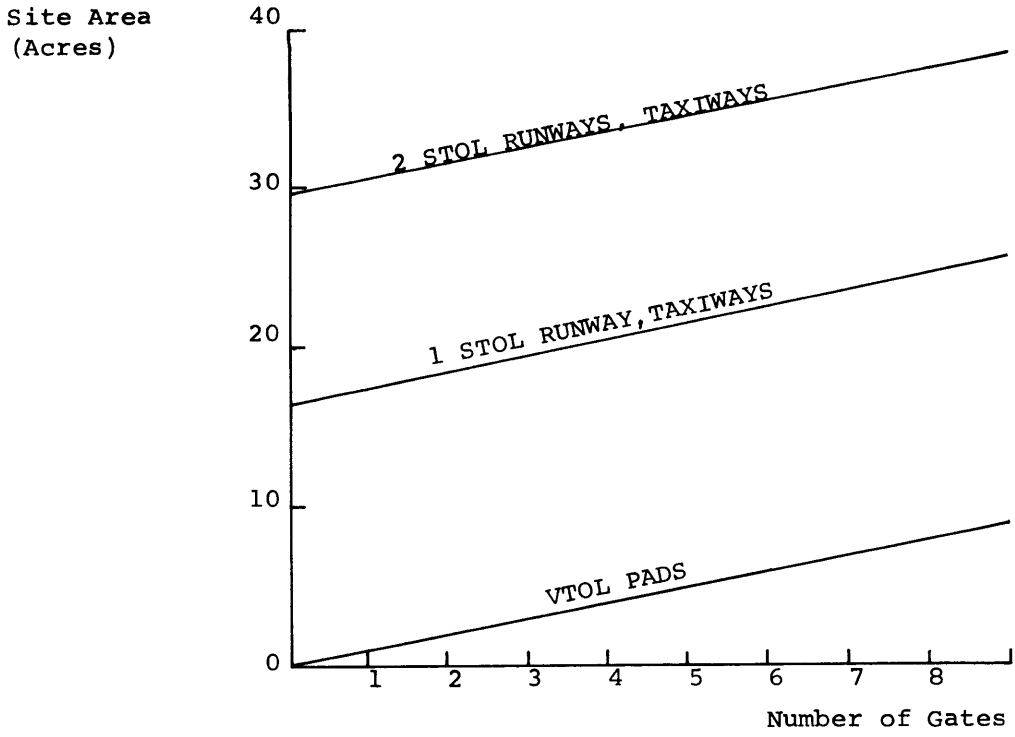
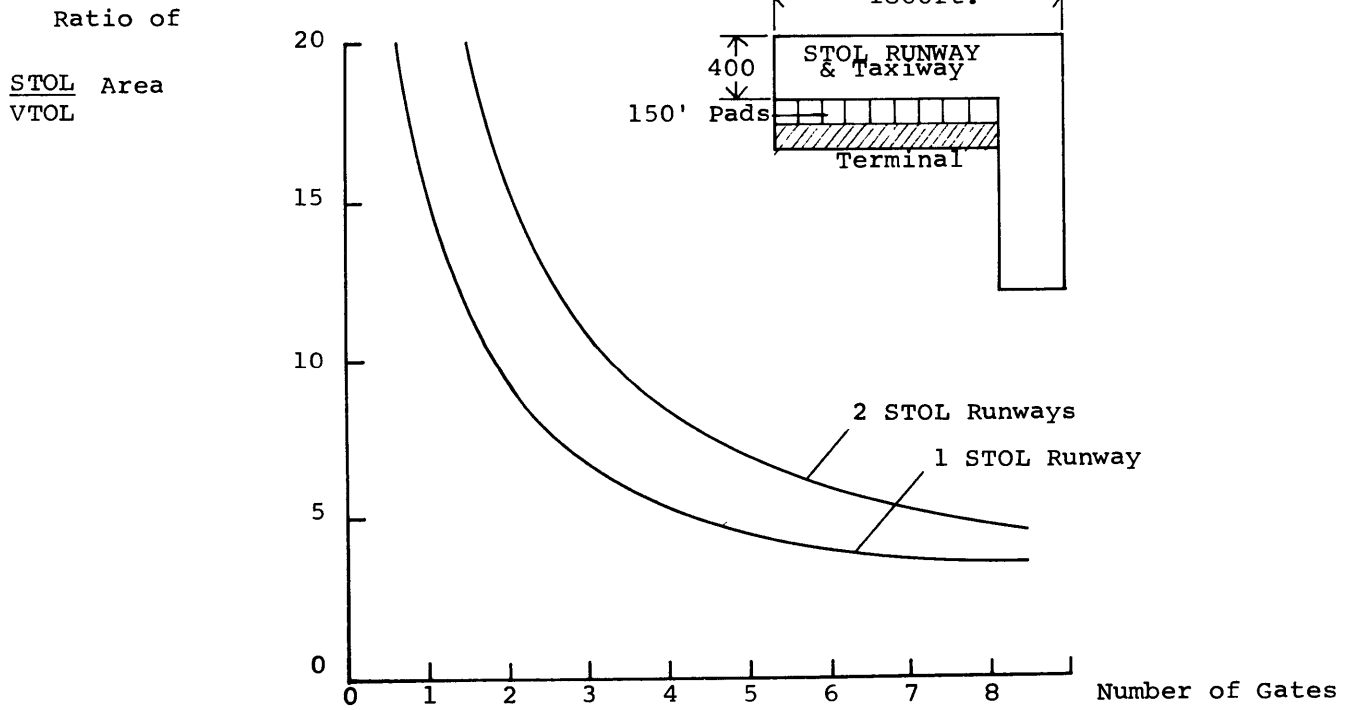

FIGURE II-2 RATIO OF STOL/VTOL SITE ACREAGE



For comparison, the acreage requirements caused by adding one and two STOL runways to the site are also given in figure III. Runway deck sizes have been assumed as 400 feet wide to cover a runway and taxiway, and 1800 feet long to cover a 1500 foot runway with 150 foot exteriors. STOL metroport requirements begin with a basic 16.5 or 29.5 acre requirement for the one or two runways plus an additional acre per loading gate.

The ratio of STOL to VTOL site areas for a given number of gates is shown in Figure II.2. As can be seen, the STOL acreage requirements are several times as large as the equivalent VTOL metroport as designed in this report. This increased site size greatly reduces the number of available STOL sites compared to VTOL sites for any given urban area.

Since groundspace is a function of the number of pads, or the traffic volume at a site, and since traffic can be expected to grow as the metroflight system is established, it is desirable initially that space for expansion be available at any site. The metroports should be capable of modular expansion, and proper planning should ensure that the number of gates can be increased at every site

using construction methods which do not interfere with existing pad operations. This should be a constraint placed upon terminal design.

E. The Site Selection Process

For a given metropolitan area, a large number of possible metroport sites should be examined to determine site feasibility for the airspace, groundspace, access, and noise factors. From the set of feasible locations, various subsets consisting of a few locations can be identified which provide a sensible pattern for the city's structure. Time phasing of the introduction of the members of such a subset should also be considered, using projections of metroflight traffic growth.

At this point all rational planning stops, and the initial steps of implementing metroport terminals in the metropolitan area begin. Community acceptance will be essentially a political process with local zoning boards, the mayor and town councils, planning commissions, real estate interest, etc., as participants. The actual sites chosen for metroports will be the outcome of a battle for local political approval of each site. While noise will

probably be used as the prime issue for debate, even if it were absent other factors such as fear of overflight, annoyance from TV disturbance, jet exhaust smoke pollution, effects on real estate values, increased ground traffic activity, etc., are real areas of concern for various segments of the populace. The establishment of a metroport proposes a radical change in urban activity usually on top of a well developed urban pattern and the proposal will meet resistance from the community simply because it is a radical change.

To gain community approval, the extent of the changes must be understood, and must be welcomed by a political majority. Noise demonstrations, which involve flying proposed arrival and departure paths with available aircraft, may be necessary since noise levels are not easily understood by laymen. Making the metroport part of a much larger real estate development such as a transportation or convention center, or an industrial park, may make the program more palatable to a city council concerned with broadening its tax base. Such a link directly and immediately demonstrates the impact a metroport can have on surrounding development, and will enable local politicians

to find a basis for supporting the metroport.

The discussion of siting for metroports has covered airspace, groundspace, accessibility, environmental, and political factors. The process for obtaining approval for a plan of implementating metroports requires careful study of all of these factors. Here we have been interested in determining requirements for VTOL metroport design which would assist in this process. Briefly, the indicated desirable characteristics are: elevated deck operations, elevated structure for air rights, small site acreage, and modular construction for expansion, using construction methods which allow operations at the site to continue. These characteristics are general and may not pertain to certain locations. However, they form a basis for the metroport designs of this report.

Chapter III

General Design Considerations for VTOL Metroports

A. General Design Factors

A.1. Minimum Walking Distance

Conventional airport terminal buildings tend to be very lengthy, strung out arrays of gate positions. The main determinants of size and length are the requirements for simultaneously parking a large number of aircraft, and the gate spacing as determined by aircraft size and maneuvering distances for parking.

The number of gate positions required can be reduced by reducing gate occupancy times particularly during peak periods. It is assumed here that the terminal building, boarding procedures, and aircraft interior will all be designed to achieve turnaround or occupancy times less than 10 minutes for 80-100 passenger aircraft. The number of required gate positions can also be reduced if gate positions are shared amongst airline systems. The metroport designs of this report all assume that gates are shared or that only one metroflight system is using the terminal.

The gate spacing can be reduced by using "nose in"

parking. This procedure is adopted in this report where the VTOL aircraft air taxi onto and off the landing pad. The size of the landing pad as determined by downwash, rotor diameter, wing span , etc. then specifies the gate spacing. Here we have assumed a pad size of 150 x 150 feet.

The result of these assumptions is a very compact VTOL metroport terminal. Average and maximum walking distances will be much shorter, and finding one's way through the terminal should be much easier because of shorter, less complicated paths.

In analyzing existing designs for VTOL metroport buildings, and in synthesizing new designs under this study, simple methods and simple criteria were used. The basic method was to plot all routes the passenger was likely to take through a given design, then to subject these routes to the criteria: Is his next objective always within sight? How far must he walk? How high must he climb? How many steps of a process must he undergo? How much time must he spend waiting? Where might he go wrong? What if he is carrying a lot of luggage, or has a large family, or is in a wheelchair, or is very old? By means of these questions, the routes and processes

gradually become shorter and simpler as design work progressed. Building areas for various parts of the route were assigned based on simple arithmetic. General design objectives became clearer as the process progressed: A straight, short, direct path for the passenger, with no climbing and few turns; a simple, compact, economical terminal building, capable of future expansion; a straight-forward flight deck configuration that would permit maximum efficiency of aircraft operations.

A.2. Space and Capacity Criteria

Since VTOL commuter passengers are likely to be characteristically quite different than ordinary airline passengers, the usual handbook criteria for space requirements in terms of peak hour or annual passenger flows were not used. The short haul commuter passenger is likely to have less bags, to arrive closer to departure time, and will have simpler ticketing and boarding problems. These differences are substantial enough to invalidate any rules of thumb. A comprehensive computer simulation model was built and run in order to test the operation of some of the metroports of this report. It is described in Reference 21.

The simulation produced data on escalator, or elevator usage, cars parked in curb areas, passengers waiting in gate areas, etc. for varying assumptions about passenger characteristics. In this way the designs could be checked for critical factors, and a balanced design produced. For the multi-level, modular metroport designs of this report, it is important that proper space be assigned for parking, curb areas, interior floor space, elevators, etc. to provide a smoothly functioning terminal at every stage of expansion.

The operation of the simulation showed that simple calculations could be established for use by the designers during the design process. When a metroport design was formulated, a simulation run could be set up in a few days to check on its operation. It did not prove necessary to redesign any of the metroport terminals. A few minor changes were indicated which could be easily incorporated.

A.3 . Modular Construction of VTOL Metroports

Two virtual certainties in any VTOL metroport venture are that it will have to expand its capacity at some time in the future, and that it will be unable

to restrict its flight operations appreciably during the process of expansion. Accordingly, consideration was given to the design of a modular system for the construction and subsequent expansion of a VTOL terminal.

In conjunction with the flight deck configuration studies described in a following section of this chapter, various potential systems for the prefabrication of metroport components were studied. This work was undertaken with the expectation that construction costs might be reduced, that a higher standard of operation efficiency and safety might be ensured on a country-wide basis, and that modular expansion might be made easier. After a look at the widely varying requirements of a number of potential VTOL metroport sites in the Northeast region, it was decided that only the single-pad flight deck structure could be expected to remain constant from site to site, and that the parking garage, terminal structure, and access roadways should be locally designed and built, in accordance with rigorous national standards, but in response to local conditions of site configuration, foundation conditions, roadway access, flight paths, labor conditions, material availability, and design tradition. The development of a

modular flight deck structure is described in more detail in Chapter IV.

With respect to the expansion of an already-existing metroport, it will be noted that most of the design in Chapter V are configured in such a way that a pad or pair of pads, together with the corresponding terminal and parking structures, can be added by simply extending the existing structure 150 feet. With both the prefabricated flight deck and the site-fabricated terminal building, interruption of the air space surrounding the operational flight deck can be minimized by utilizing either a Lift-Slab or a push-up method of construction, in which building floors are constructed on the ground and jacked into place from below, without the need for cranes or other tall machinery.

A.4 . Design Standards

There is an opportunity in building a new metroflight system to standardize the design and operation of the metroports to some degree. While metroports cannot be identical over the range of possible sites because of surrounding land usage, different foundation problems, etc. it is possible

to provide design standards or guidelines for such items as information systems, displays, flight deck design, automatic check-in systems, baggage systems, etc. The standardization should be carefully done to maintain the benefits of lower costs and familiar surroundings for the passenger, and yet leave freedom for various design cases, or variances in system operations caused by growth or change. It is especially desirable for the automatic check-in systems that the passengers be able to use standard credit cards, and be able to feel familiar in interacting with the machines.

At present there are no regulatory requirements for noise, pollution, or safety of operations for a VTOL metro-flight system. It is probably impossible to develop a complete set of new regulations for these areas until experience with operating metroflight systems has been gained; but initial regulations and guidelines are legally required. Hopefully, with careful study one can establish a wise set of rules which would guide metroport siting, design and operation, and which would retain some flexibility for the designer and operator. To ensure that opportunities for future developments are not precluded, it would seem advisable that a flight operations program which involves flying various VTOL aircraft onto elevated deck structures

should be carried out to investigate various operational questions arising from simultaneous deck operations, night flying, downwash and wind effects, building noise and impact loads, the optimal design of the flight deck, etc.

B. Previous Work in VTOL Terminal Design

VTOL terminal designs found in the literature fall broadly into three categories, which might be called for convenience the Flat Deck Linear Group, the Polygonal Group, and the Pigeon Hole Group. It is true of almost all the designs in the three categories that little thought was given by their designers to anything but the handling of the aircraft, so the discussion which follows will be directed mainly toward that aspect of the designs.

The Flat Deck Linear Group share in common a more or less linear arrangement of gate positions served by one or more separate landing and takeoff areas connected to the gate positions by taxiways.¹ The resulting flight decks are comparatively large, ranging in area up to

1. See References 6, 9, 19, 26, 37, 47.

95,000 sq.ft. or two acres per gate, and taxi times and occasional air holding or taxiway waiting times for the landing-takeoff areas would be necessary. Against these disadvantages can be weighed the fuel cost advantage of allowing some horizontal takeoff run to the aircraft. Some superstructure is present in each design to bring the passenger from lower levels to the door of the aircraft. Parking and roadways are provided in levels below the flight deck.

The members of the Polygonal Group each contain six or eight gate positions in a hexagonal or octagonal array.² Flight deck area is on the order of 30,000 sq. ft. per gate position, due to the elimination of separate taxiways or takeoff pads. Passengers are brought up from a central processing facility below and are distributed radially outward to the six or eight aircraft. The primary disadvantage of such a scheme is its inability to be constructed rationally or economically in a configuration of more or less than six gate positions; it is a closed form. Generous airspace is necessary all around the perimeter of the deck, a requirement which would often be difficult to fulfill in an urban area.

2. See References 6, 9, 31.

The Pigeonhole Group is characterized by the raising and lowering of aircraft, on elevators or ramps, to and from stacked "pigeonhole" gate positions.³ The intent of such an arrangement is to reduce land requirements in a tight urban situation. Of these schemes, the most efficient requires 18,000 sq.ft. of land per gate position, while the two least efficient require 31,000 and 34,000 sq.ft. per gate, respectively. The greatest problem raised by these designs is the time, and sometimes the wait, required for the aircraft to ride the elevator at each stop, a time which would become especially objectionable on multi-stop journey. (One designer proposes to save part of this delay by catapulting the departing aircraft out the side of each lower deck!) A further problem is that of the potentially hazardous containment of noise, fumes, explosion and fire between structural floors of the terminal, as most of the designs call for the aircraft to taxi under its own power even on a lower floor of the terminal.

3. See References 6, 26.

One design which is in a class by itself is the floating airport proposed by Cooper B. Bright.⁴ This is primarily a STOL-port, but is mentioned in this analysis for the interesting vision it evokes of a floating VTOL airport. Many potential urban VTOL airport sites are over rivers, bays or harbors, and a floating structure might offer certain cost advantages over a structure with permanent foundations. In this study no floating airports were designed, for the reason that while a floating structure cannot be located on land, a structure on columns can usually be built over water, on driven pilings or piers. Thus the designs in Chapter V are intended for use over either land or water, depending upon local circumstances.

C. Flight Deck Configuration Studies

Following analysis of previous work in the field of VTOL airport design, work was begun on the synthesis of new designs for VTOL terminals. An initial task was to explore diagrammatically possible flight deck configurations, assuming that the aircraft are capable of taking off and landing from their gate positions. In figure III.1,

4. See Reference 8.

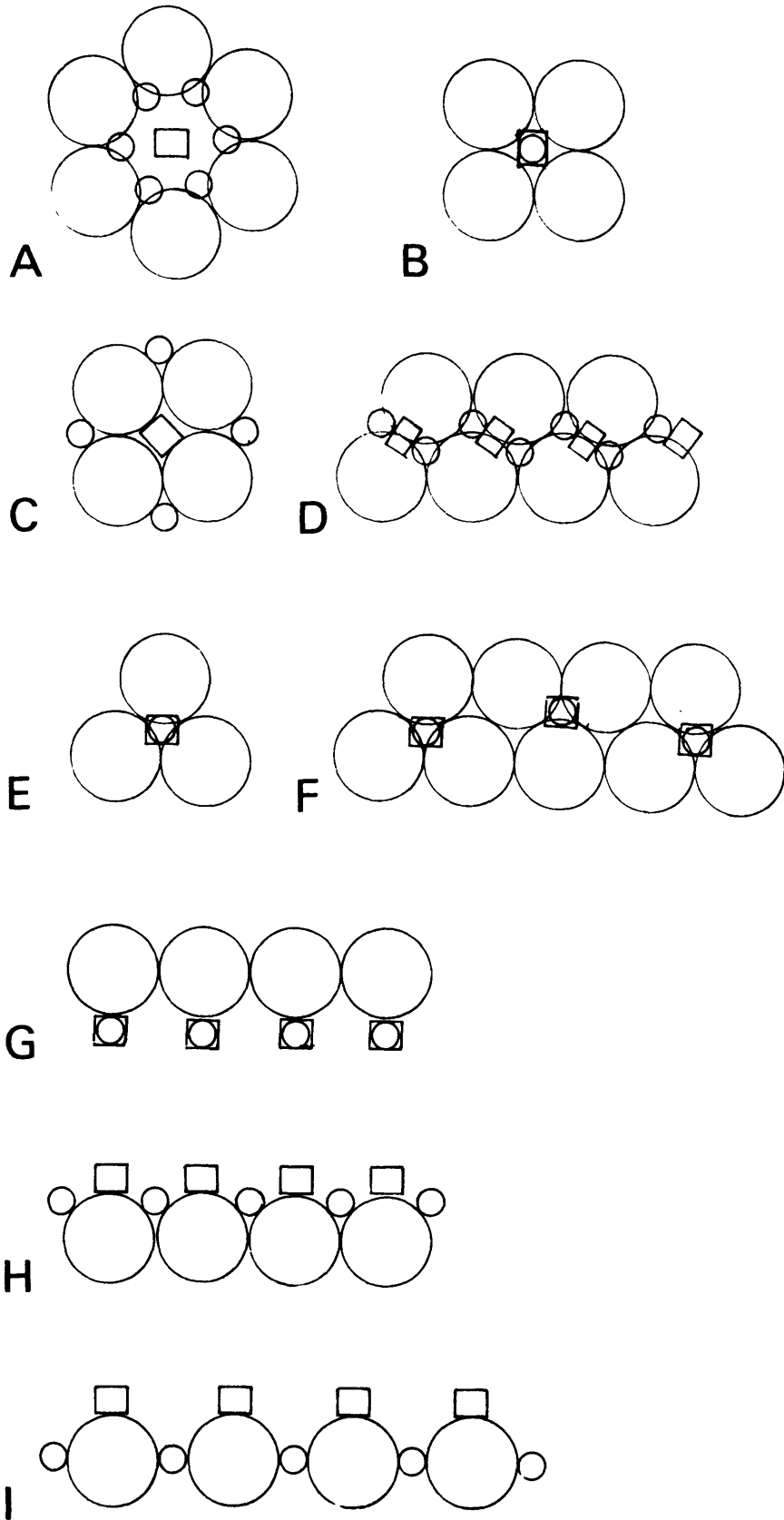

Fig. III-1. Possible Metroport Flight Deck Configurations

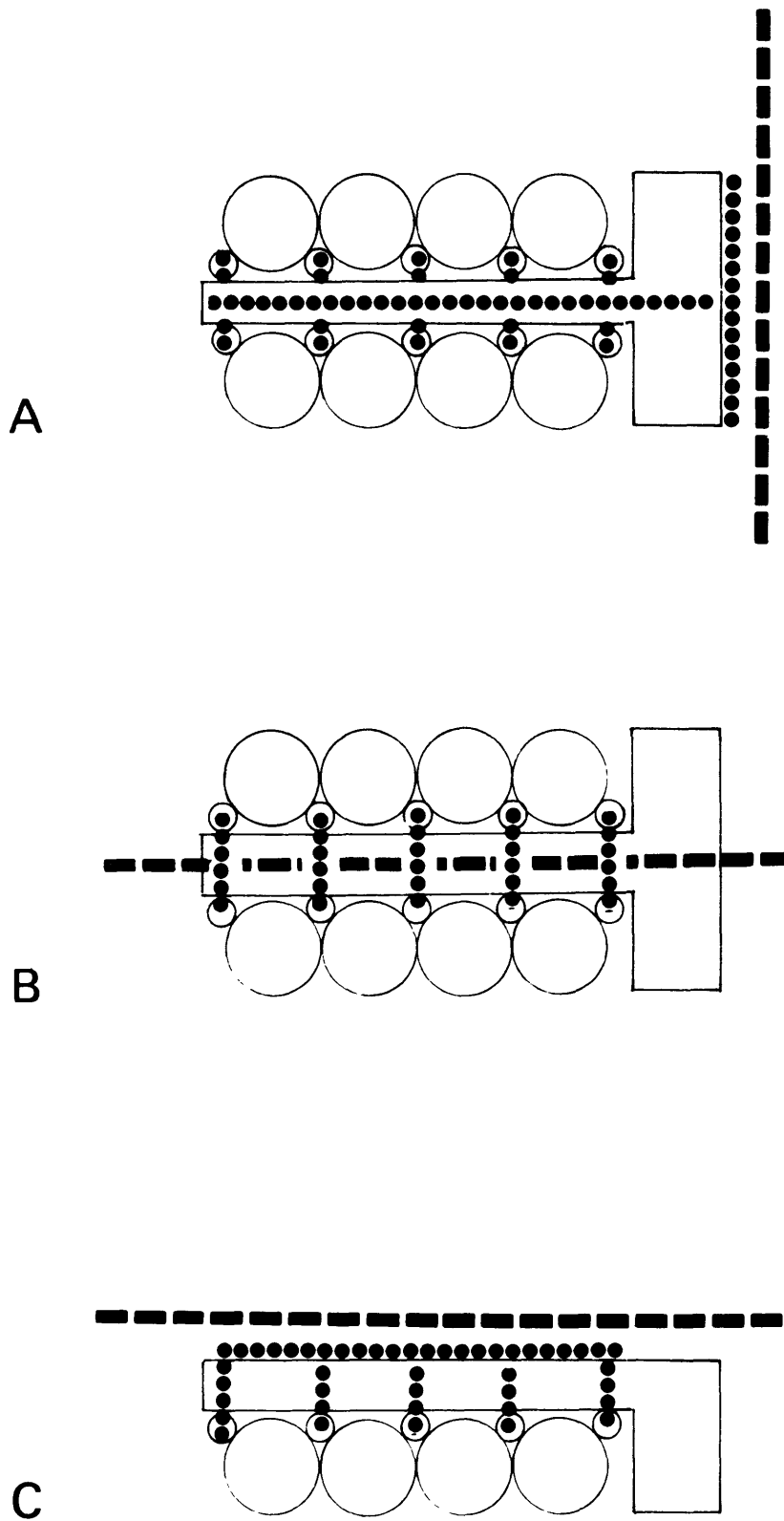

Fig. III-2. Three Possible Relationships Between Automobile Access and Passenger Flow in a Linear Metroport.

schemes A, B, and C represent cluster configurations; the small circles denote passenger loading and unloading points, and the small squares, baggage handling facilities. A is, of course, the polygonal scheme already mentioned. C, though sharing many of A's problems, is the basis for detailed study #7 of Chapter V, the Central Scheme. Schemes D through I are linear schemes which, unlike A through C, are capable of easy expansion. Schemes E and F illustrate how a staggered arrangement of pads allows the use of only one gate lounge per three pads. In working with these two schemes, however, it was discovered that insufficient space actually exists to move all the passengers and baggage for three pads through a single common area. The staggered arrangement, furthermore, is not as easy to expand in a rational manner as a double row of pads in direct correspondence. Schemes G and H appear in various forms in the detailed studies which follow, sometimes in a single row of pads and sometimes doubled up. Scheme I, with passengers entering and leaving between the pads, is both wasteful of space and obstructive to the flight deck, and was not developed further.

In figure III.2, we see three exploratory diagrams

of how vehicular traffic (dashed line) might be related to passenger flow (dotted line). In diagram A, passengers must move from the very end of the terminal building to their respective gate positions, and the average walking distance is relatively long, with the maximum reaching roughly 800 feet. In certain urban situations, however, such as at a pier in a river, such an arrangement may be necessary, and it is explored further in detailed study # 3 of Chapter V, the Moving Sidewalk Scheme. Diagram B illustrates how a similar scheme with vehicular traffic running under the length of the building can cut average walking distances. At least one change of level is required of the passenger, however. In Diagram C, we see that if we use just half of scheme B, vehicular traffic can move at the same level as pedestrian traffic, and a very direct and simple arrangement is the result, though some loss of efficiency in site utilization is evident.

Chapter IV

The Design of Components for VTOL Metroports

In the course of designing metroport terminals, it has been quite clearly demonstrated that the overall layout and design is crucially affected by the assumed design and operation of several major components of the metroport. In this chapter we shall discuss these components in general terms before proceeding to the next chapter which describes the overall designs.

A. Passenger Information Systems

To ensure smooth, efficient in-terminal passenger flows, a well designed, automated passenger information system is required. Properly sized displays should be integrated into the terminal design at key points to ensure that the passenger can determine where he is going, and what is occurring relative to his flight.

As he arrives at the metroport by auto, taxi, or subway the departing passenger needs to know where to enter the terminal, where to park, how to find his way into the passenger processing system, and preliminary information on his departure. Parking signs should indicate the way to available spaces from access roadways.

Signs on the parking floors or subway stop areas should indicate the way towards specific gates, and the gates and times for imminent departures. Once inside the terminal, passengers should have up to date information on the status of all flights from signs driven automatically from the terminal computerized check in system.

Future arriving flights should be listed when on expected arrival time is available and should indicate the expected gate assignment. When it arrives, the listing should list the actual time and gate, and should distinguish the listing by using a back lighting or color coding scheme.

Future departures should be listed with on expected departure time and gate, and an indication of space availability such as reservations only, number of standby passengers, etc. As the reservations are closed, the space available after standbys should be listed for late arriving reservations holders, and when the boarding process is finished, a back lighting or color coding should indicate this fact to stragglers who are still rushing towards the gate.

For the deplaning passenger, path signs should clearly indicate where he should go to collect his baggage, to

enter the parking area, subway or taxi stop area, to transfer to other flights, and to get information on accommodations, meals, transportation, or the map for the surrounding area.

The information displays should be standardized to the extent that a passenger can feel familiar with them in any metroport.

B. Automated Passenger Processing System

The Passenger processing can be described by the general functional flow diagram of figure IV.1. It shows the paths which all departing and arriving passengers together with greeters, wellwishers, and baggage, must follow. It is the starting point for the passenger flow simulation of reference.²¹ This diagram may be utilized to follow a typical passenger's passage through one of the metroport terminals as envisaged in our work.

As the passenger enters the terminal he should come first to a row of automatic check-in consoles (figure IV-2). The open front of any available console will accept any suitcases he wishes to check, and hold them there in a modular baggage tray until the ticketing process is complete. The display screen on the top of the console will request that he insert his credit card in the slot provided. It

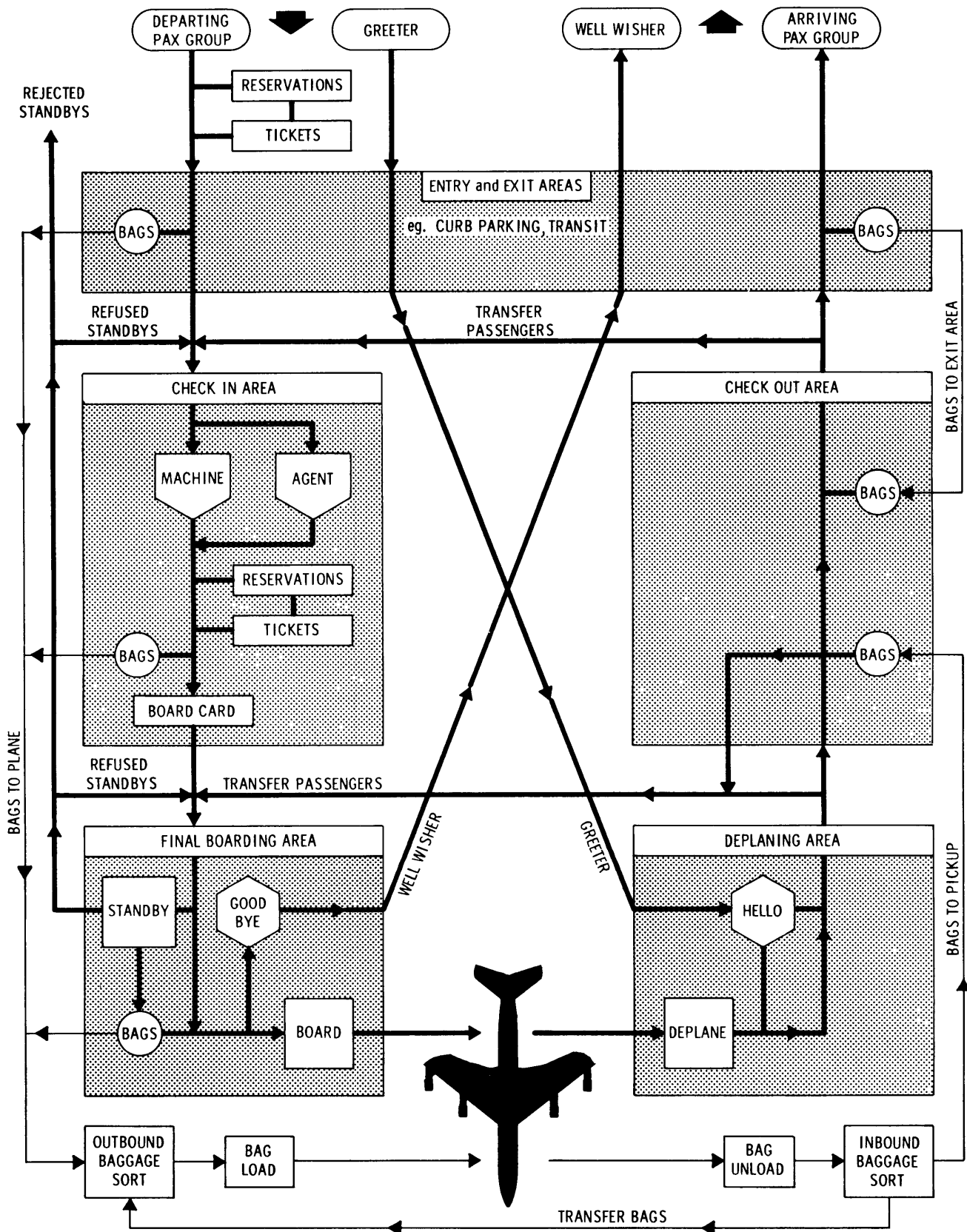

Fig. IV-1 Functional flow diagram for passenger processing.

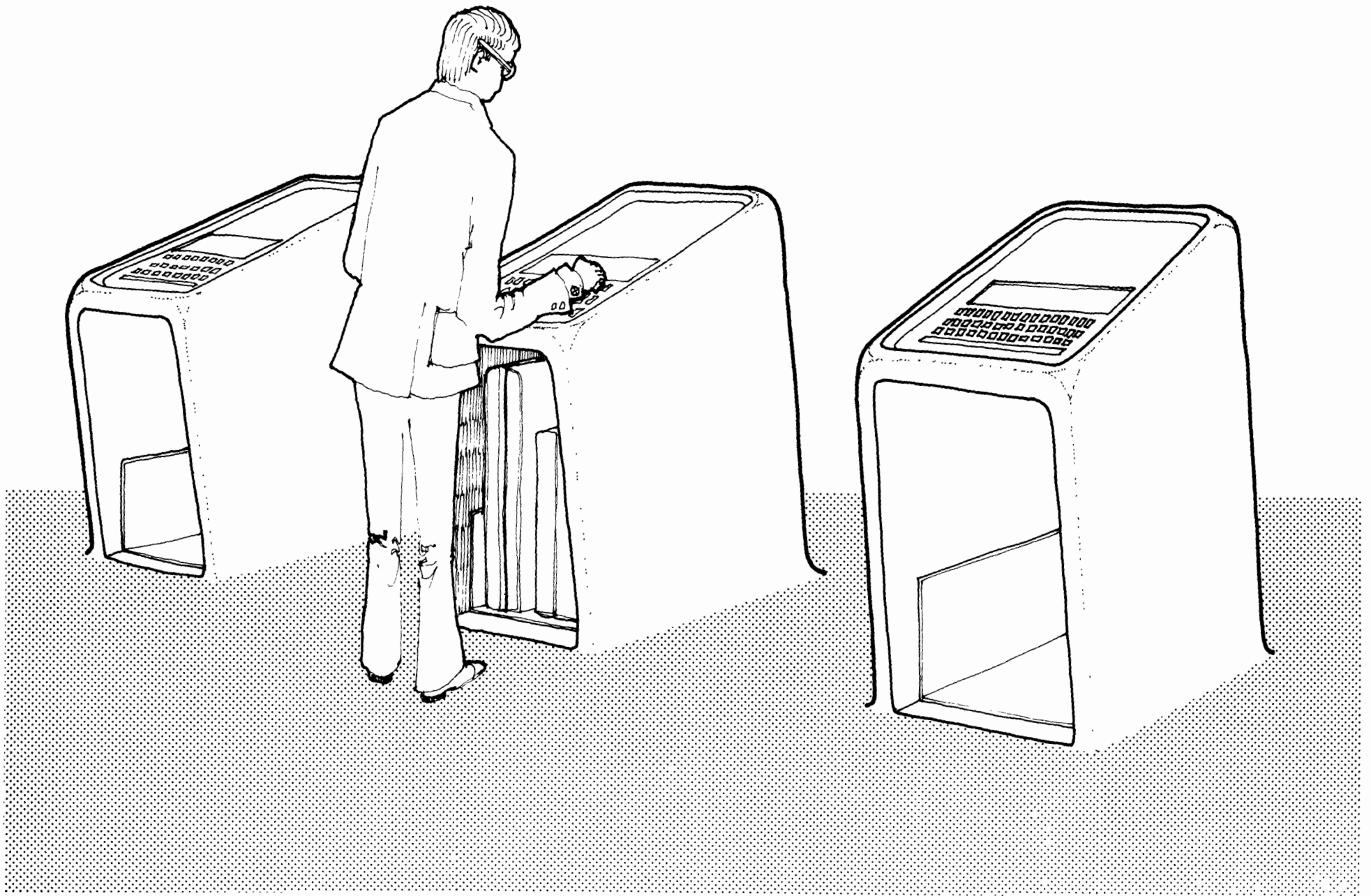

Fig. IV-2. Automatic Check-In Consoles

will then ask his destination, and whether he has a reservation. If he has a reservation, it will be checked in the central reservations computer.

If he has no previous reservation, he will be offered:

- 1.) a reservation on next flight
- 2.) a stand by number on next flight (s), and
a reservation on the next available space

He will make a decision to buy or not buy the offering. If he buys, a charge is made against his credit card, and the console issues a magnetically coded boarding card which also acts as a receipt. The console display will then give the appropriate gate(s) and boarding times(s), and any other pertinent information. The gate(s) and time(s) will also be printed on the boarding card as a reminder. Simultaneously, a magnetically-coded tag will be applied to the baggage tray, and the tray and baggage will be lowered to a conveyor in the baggage system below the floor, to be replaced by an empty tray for the next passenger.

If the passenger is unfamiliar with the automatic check-in process, or wishes to use cash or a normal airline ticket, he will be directed to the normal check-in

process with a passenger agent.

The next processing step occurs in the final boarding area or gate area. Although a single gate attendant will be present to answer queries, etc., an automatic turnstile will be used to control the boarding process. The boarding card is inserted into a card reader to validate the actual boarding of a passenger. For ease of entry, it will be an open turnstile which closes only when one attempts to pass through without validation. The boarding card is read, checked against the reservation list, and the passenger name is added to the required passenger manifest. At some time shortly before departure, unclaimed reservations are voided, and the gate indicates by a lighted display that it will accept standbys of certain numbers. Each standby will insert his boarding card, place his baggage on a nearby conveyor, and board the flight. The reservation held in his name, and any other standby numbers for intermediate flights, are automatically cancelled.

At departure time, the turnstile or control gate will close, blocking further entries and acceptance of bags. As the flight departs, a departure message indicating expected time of arrival, the available space on board, and connecting passengers will be sent to the computer

at the destination terminal. This message will be initiated by the gate attendant upon observing actual departure.

C. In-Terminal Passenger Flow Paths

Much study was given in this project to the problem of getting passengers to and from the aircraft and from and to the gate lounge area. A number of possible alternatives are shown in the accompanying diagrams. Three ways of getting passengers up and down from a lounge under the flight deck were explored (Figure IV.3). Scheme A involves a stair which rises parallel to the fuselage of the aircraft and connects to it with a folding hood. B shows a stair which rises perpendicular to the fuselage, and C is an elevator arrangement. All three schemes tend to cause complications in the structuring of the flight deck surface. Schemes A and B require the passenger to climb a considerable height of stair. An escalator could probably be adapted mechanically to such schemes, but for the difficulty and danger which would arise from the backing up of traffic whenever passengers had to wait at the door of the plane, a problem which could be solved only by making the top landing large enough to hold 30 or 40 persons. Scheme C leaves the last-minute passenger in the lurch, for the

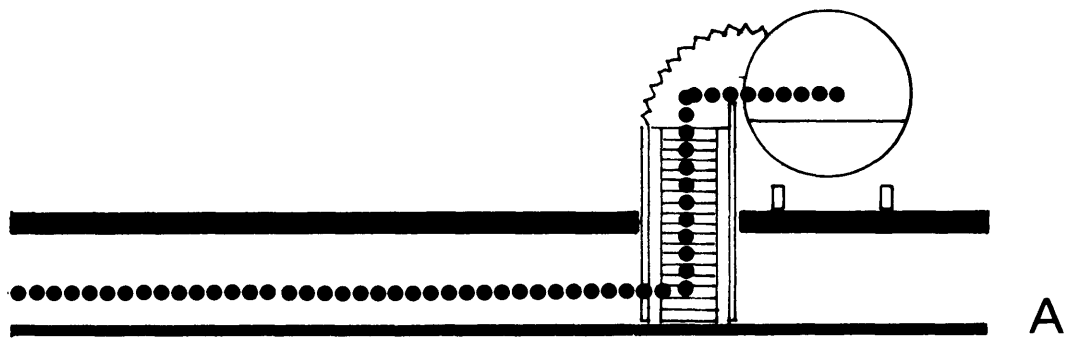

A

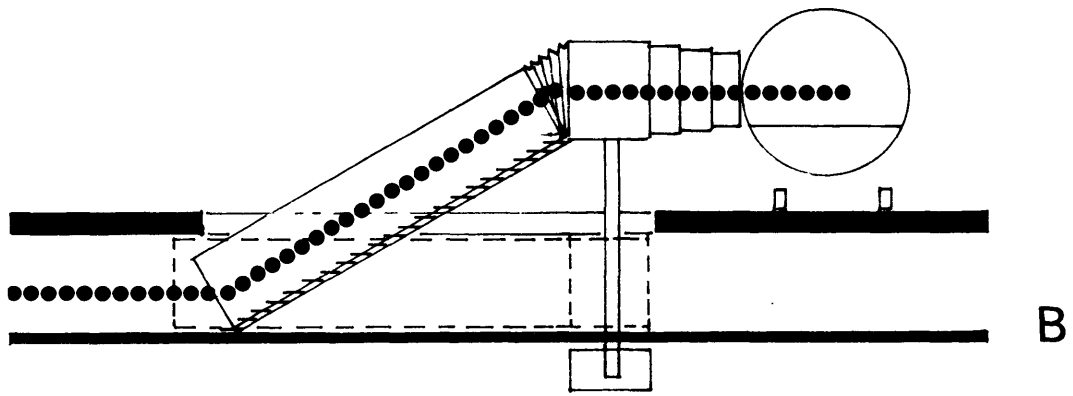

B

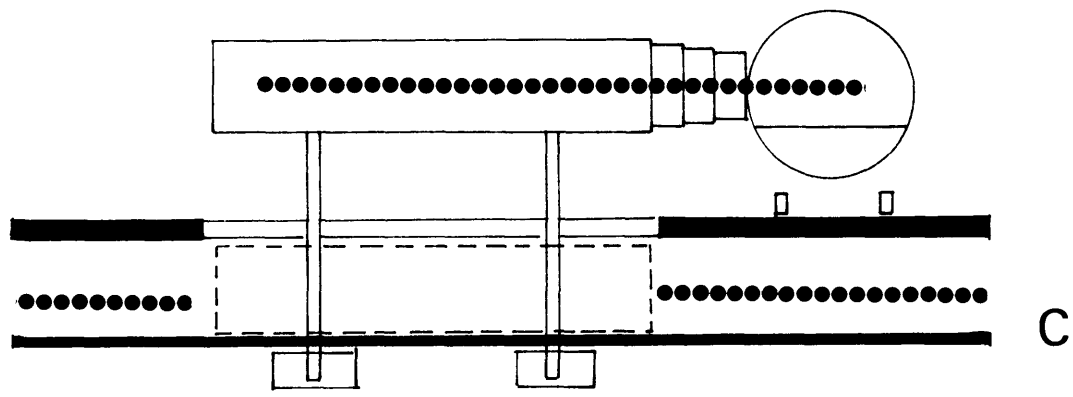

C

Fig. IV-3. Devices for Boarding Passengers from Below the Flight Deck.

elevator must remain in the raised position during the entire boarding process. If a retracting stair or escalator were attached, the arrangement would probably work fairly well, but a rather large and expensive piece of hardware would be the result. For all these reasons, it was determined that gate lounges should be placed at roughly the same level as the floor of the aircraft, not a level below.

In Figure IV.4, diagram A, we see how a very short telescoping loading bridge could connect with the nose of a parked aircraft, under a raised cockpit, to lead directly to and from the aisle of the cabin. Diagram B shows how the dead-end street this creates could be opened by an under-tail exit to enable extremely fast, efficient, simultaneous, one-way enplaning and deplaning. This scheme was tried in a number of metroport design studies, but was finally dropped because it involves bringing deplaning passengers into the terminal at a point rather remote (by more than a plane length) from where they must eventually go. Scheme C was discarded because it would require a very precise location of the aircraft on the pad. Scheme D is more flexible, but works only for wingless or folding-wing aircraft. E, F

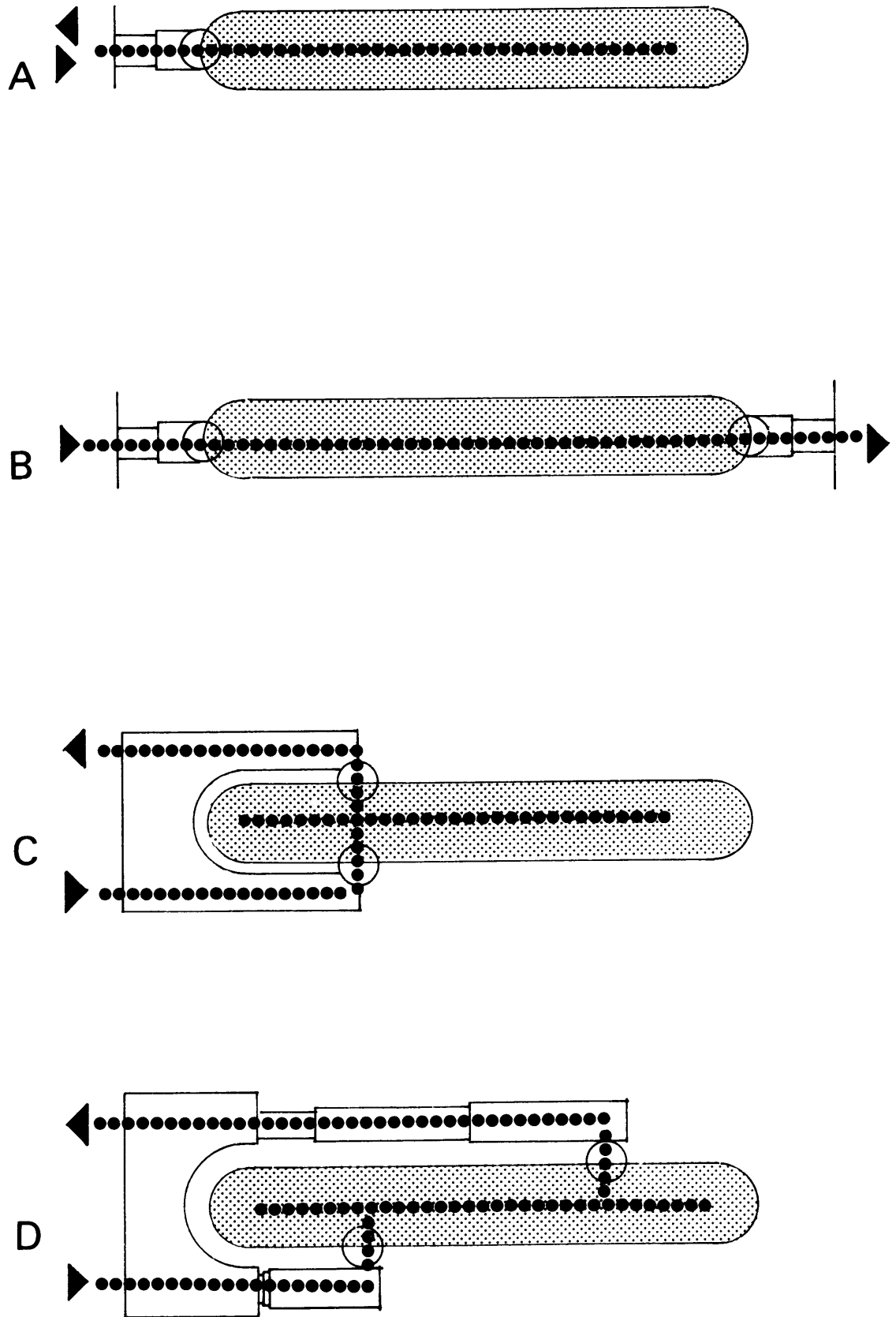
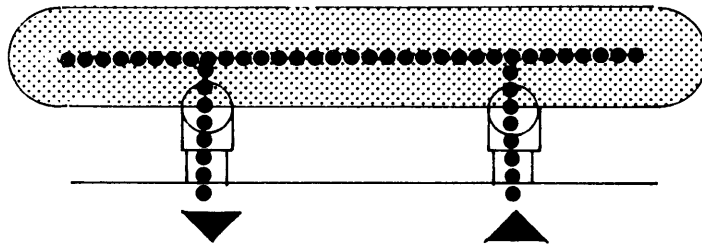
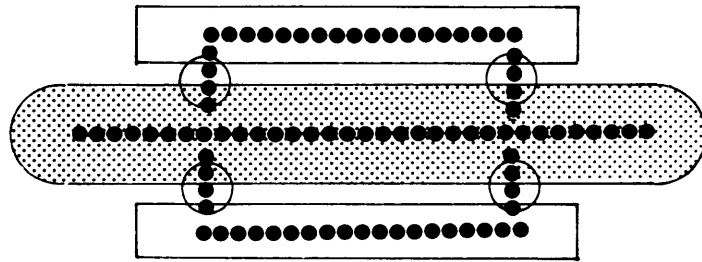

Fig. IV-4. Plan Views of Aircraft Loading and Unloading Patterns.

E



F



G

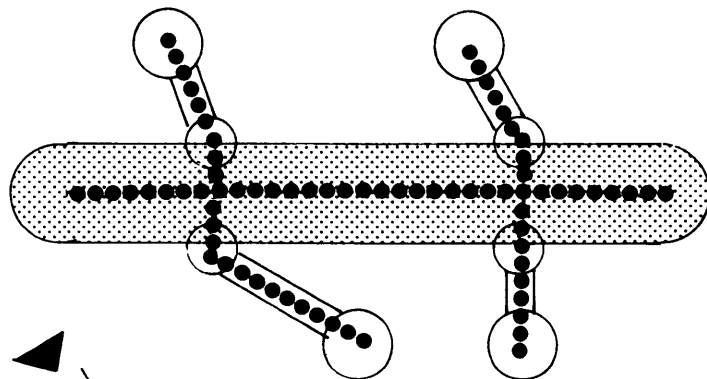

H

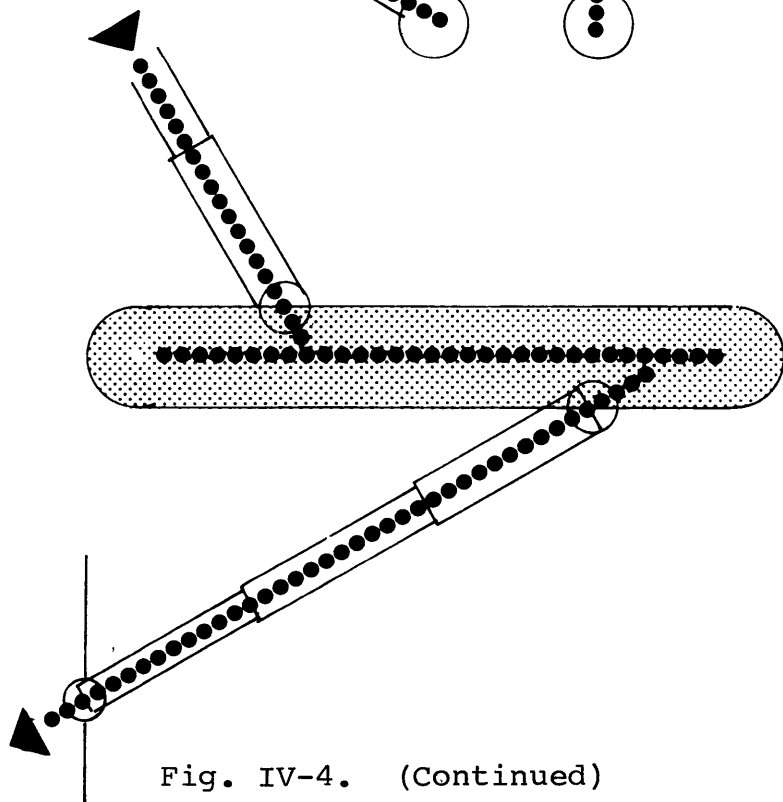

Fig. IV-4. (Continued)

and G were not developed because H was found to be much more flexible: a pair of long telescoping loading bridges, much like those currently in use at conventional airports. Such an arrangement is capable of connecting with a plane parked broadside or nose-in, or almost any position in between, and can fit almost any combination of aircraft doorways. It can, in fact, under proper circumstances, function almost as efficiently as Scheme B on the previous page of diagrams.

D. In-Aircraft Passenger Flows

The critical element in vehicle turnaround times for present transport aircraft is the time required for boarding and seating passengers. Normally, with a single door, and narrow aisle, the process of seat selection, removing coats, and storing hand luggage is very inefficient since all these functions take place in the aisle, blocking the stream of boarding passengers.

The obvious answers are multiple boarding doors, wider aisles, or better seat arrangements. We have rejected the first two solutions because of terminal/aircraft design considerations and efficient seating utilization of the available floor space. Here we shall show an example of

BLANK

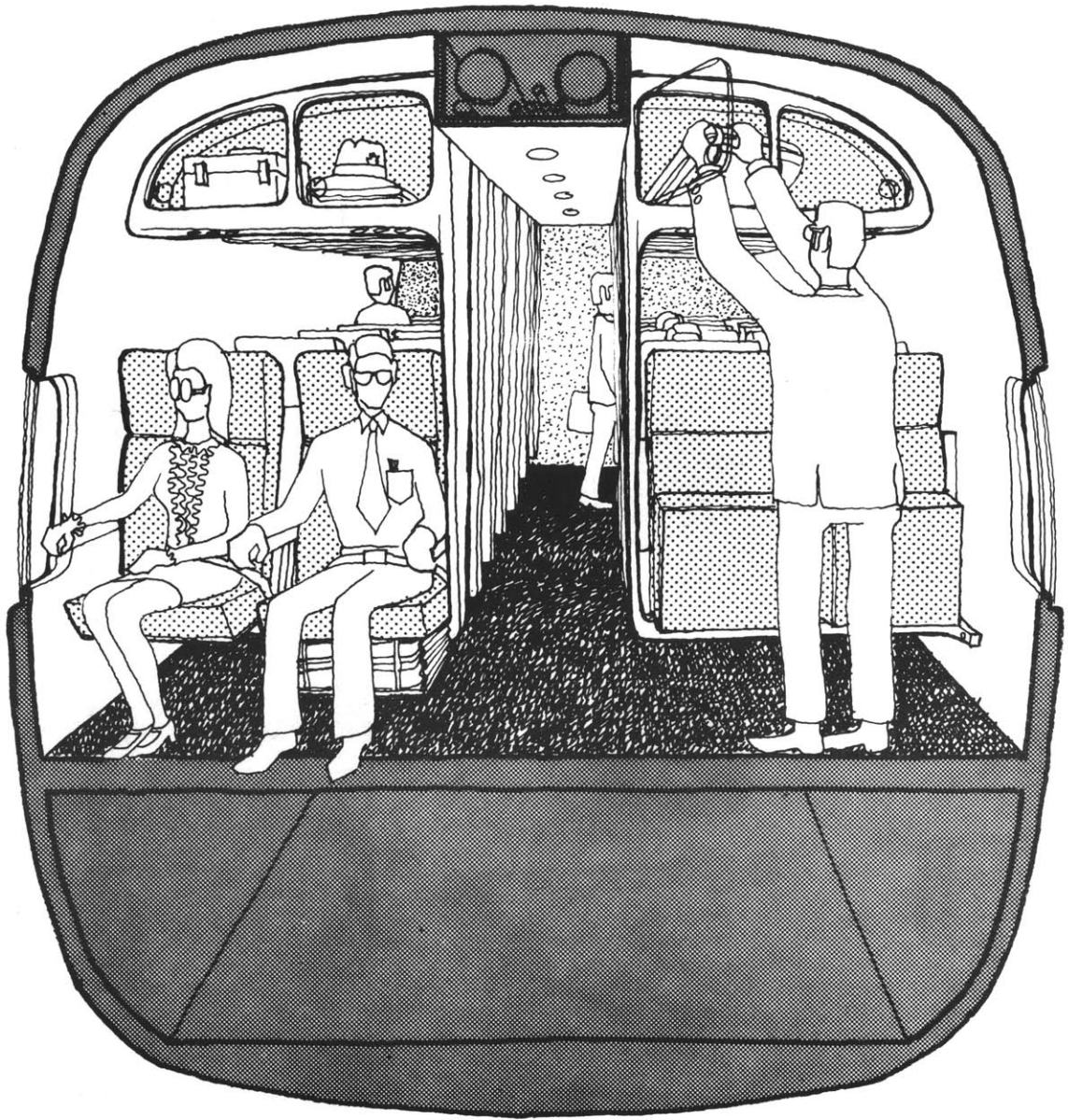

Fig. IV-5. Cross-Section of Proposed Cabin Design

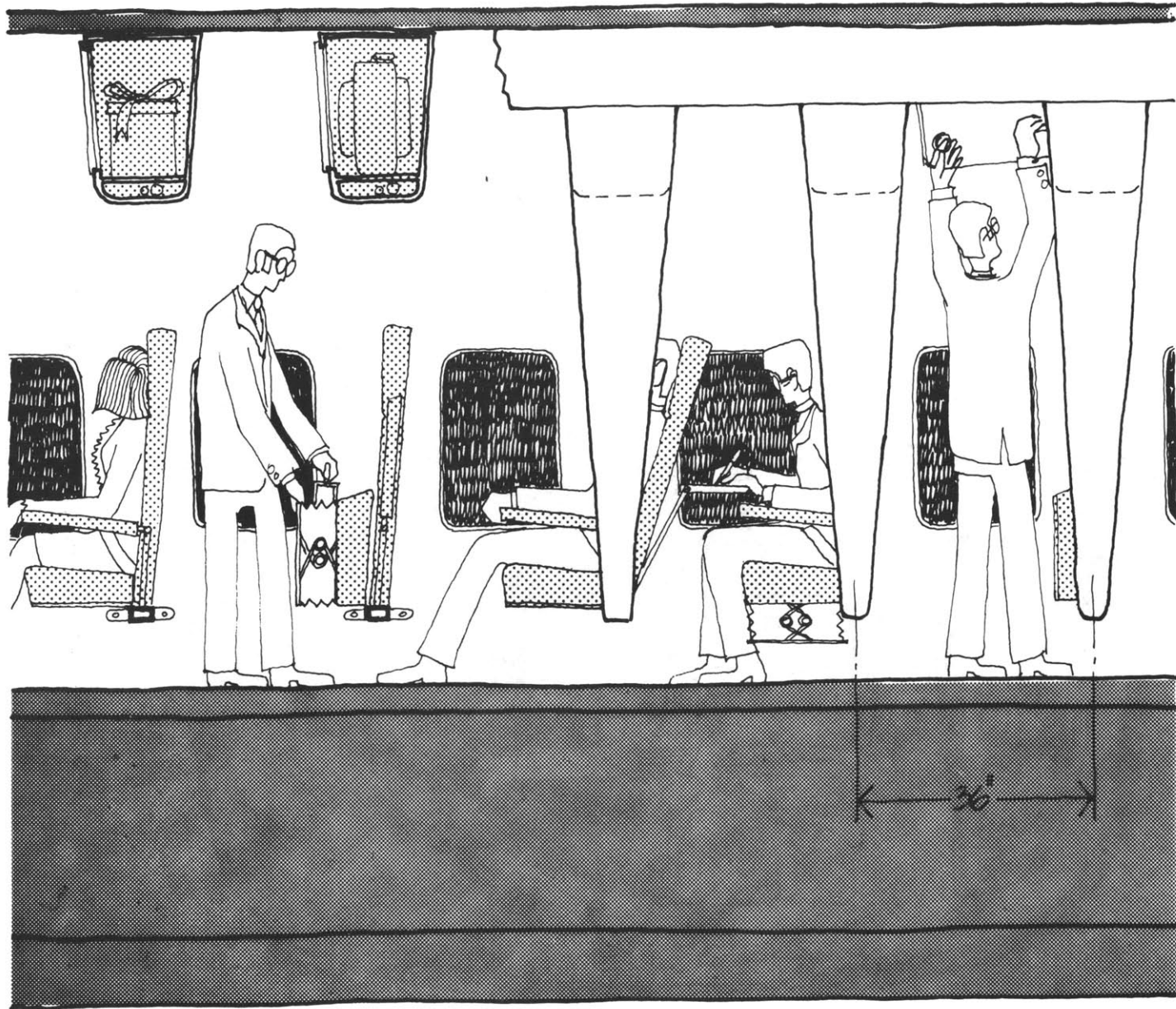

Fig. IV-6. Longitudinal Section of Proposed Cabin Design

a radically different seat design which allows, and in fact encourages, passengers to clear the aisle immediately upon selecting a seat (Figures IV.5, IV.6).

The boarding passenger need not stand in the aisle, blocking traffic, to remove and store his coat. Indeed, there are more space and better light at his seat position. The seats and armrests are folded up to provide ample kneespace for standing, and the squarish fuselage profile and the absence of the traditional overhead luggage rack leave plenty of room for standing erect. Coats, hats, and hand luggage can be stowed behind self-closing transparent doors in an overhead unit holding up to two cubic feet per passenger. The unit is placed transversally over the seatbacks in such a way that head-bumping is nearly impossible, even for the tallest man. Additional room for carry-on baggage is available in a large spring-loaded, accordian-pleated pocket on the bottom of the seat, with crash restraint provided by elastic cords with integral steel limiting cables.

As the passenger lowers his seat to sit down, the armrests lower into position simultaneously. Once lowered, the seat is locked in position until released by the passenger or by the cabin attendant. The seatbelt is

close at hand, neatly wound on a simple spring-loaded retractor. The seat may be reclined, and a tray for writing folds down from the seat in front. An extra-large, extra-low window provides an excellent view of the ground below. A large, quiet, low-velocity fresh air grille is mounted in the overhead unit along with a reading light, a sound system outlet, a call button, and emergency oxygen equipment. Each pair of seats is a semi-private compartment, not unlike those on European trains, separated from the aisle by a vertical suspension panel which supports the interior end of the seat assembly.

The suspended design of the unit permits rapid cleaning of the floor, which is totally free of obstacles. If necessary, the entire cabin carpet can be removed and replaced in a few minutes. Each seat unit is self-contained. Its frame is constructed of lightweight alloys and molded plastic. Moment connections at wall and roof are fastened with twist-lock pins, and service connections are automatically made with the over aisle service chase as the unit is snapped into place. Malfunctioning units can be quickly removed and replaced, or the entire cabin can be cleared of seats in minutes for freight operations.

The accompanying drawings are based on a seat spacing

of 36". As can be seen from Figure IV.6, spacings as small as 32" are possible without negating the basic features of the scheme. The generous height of the cabin shown in the drawings could also be reduced considerably without causing discomfort or inconvenience to the passenger.

E. Baggage Loading and Unloading

The problem of machinery for in-terminal baggage handling was not considered in great depth. Systems are currently coming on the market which are capable of functioning roughly as explained in the various design studies which follow. Thought was given, however, to how containers of suitcases might be efficiently taken on and off the aircraft at each stop, particularly at intermediate stops, where access to the luggage from all previous stops and to all succeeding stops may be required.

Several alternative locations for baggage storage in the aircraft were explored, including above the cabin, in the tail section, behind the cockpit, and in the belly below the floor of the cabin. Belly storage was found to be by far the easiest to reach and to sort. A carry-on baggage room or closet in the cabin was eliminated because

of the congestion it would create during loading and unloading of passengers.

Once belly storage was chosen, it was evident that mechanized access to a large number of small transverse storage bays along the entire length of the fuselage is required for smooth operation on a multi-stop flight. The bays are allotted to the various destinations during the loading process: when one becomes full, another is assigned to the same destination, and so on until all baggage is stored in an assigned bay. At each stop, the designated bays are first emptied of incoming luggage, and outgoing luggage is then sorted into the proper bays for succeeding stops, assigning additional bays as required.

In Figure IV-7, the small transverse storage bays are located in the shaded zones, and a number of possible conveyor access configurations are shown. Scheme B is probably the simplest and most efficient, involving a single conveyor connection at the nose of the plane below the cockpit, and a double row of bays. The inplane conveyor, perhaps powered from a universal joint connection with the outside conveyor, is equipped with shunting devices which read magnetically coded tags on the entering baggage containers and push each one into an appropriate bay.

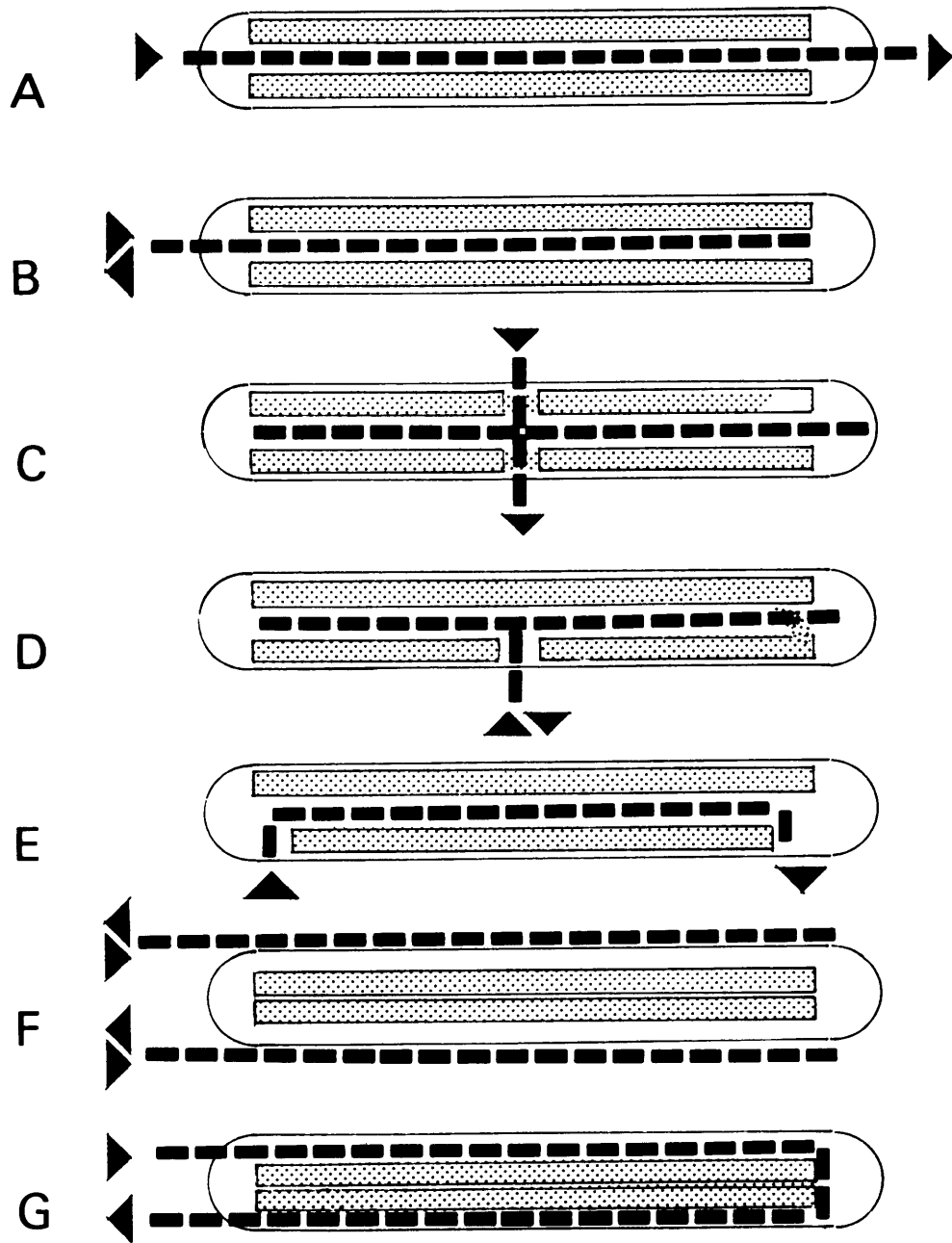

Fig. IV-7. Baggage Loading and Unloading Schemes

Each bay is automatically labelled with a magnetic code as it is assigned, so that when the conveyor is in its unloading mode at later stops it can find the bays assigned to each stop.

It is obvious that such a system because of the presence of the conveyor, uses the available belly space at a relatively low rate of efficiency. A comparatively low volume of checked baggage is expected on VTOL flights, however, leaving room for the conveyor, containers, and dividers required by an automated system. In case of any mechanical breakdown, furthermore, the conveyor space would provide for fairly easy access to the storage bays by ramp personnel.

F. The Flight Deck System

After the aircraft itself, the mechanical component most critical to the success of a VTOL air system is the flight deck. In high-density, all-weather VTOL service the flight deck must be much more than a flat piece of concrete or steel capable of supporting the loads of landing and taxiing aircraft; it must also serve to absorb noise, to control the weather in the immediate vicinity, to provide all mechanical services required by the aircraft, and to provide protection against crash and fire. It is a recommendation of this report that the flight deck system be the subject of a thorough research and development effort, including operational testing, and that the developed system should be made mandatory for every VTOL airport, for reasons of safety and efficiency, much as a

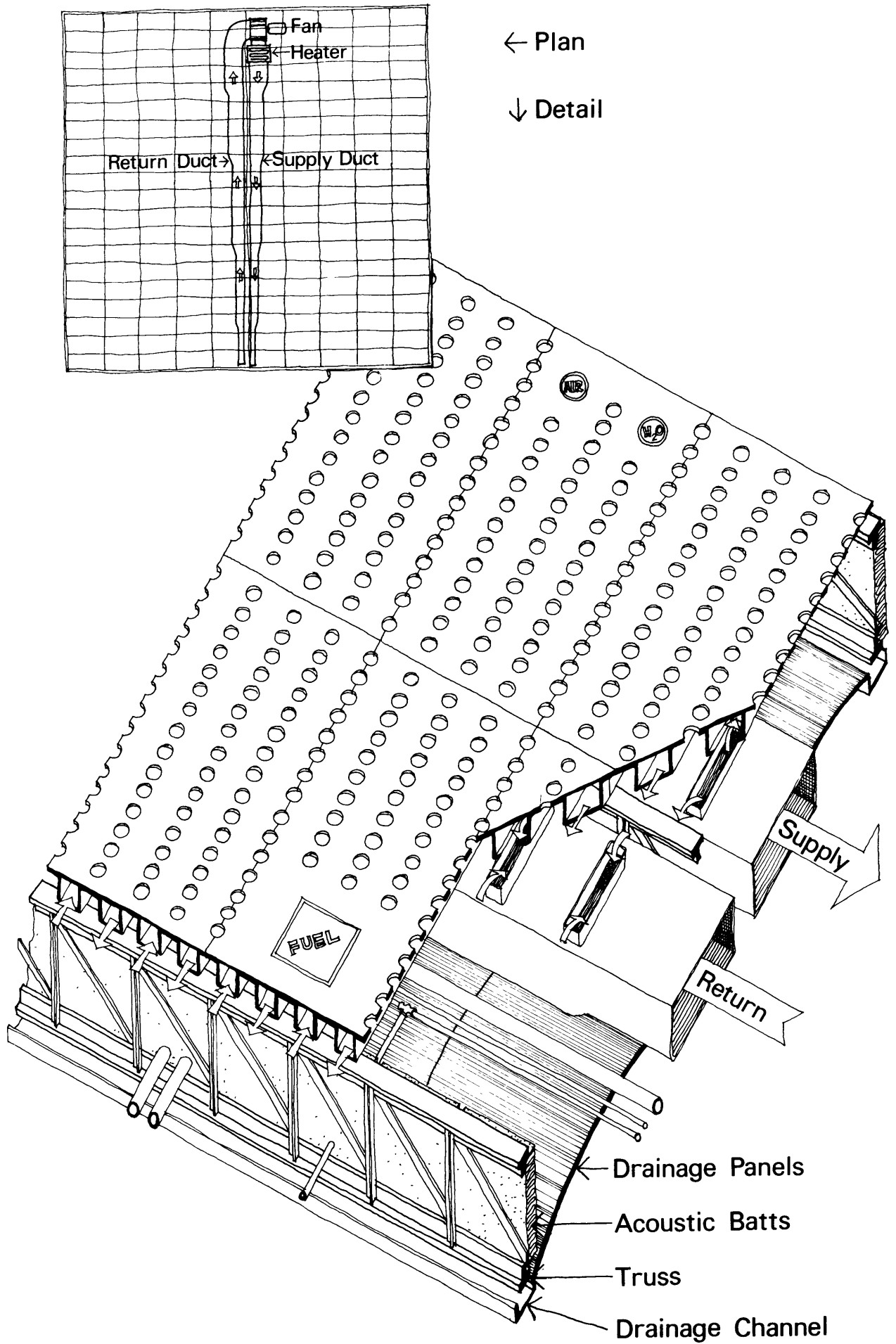

Fig. IV-8. The Flight Deck Structure

standard runway system has been established for CTOL operations.

For an elevated flight deck, a longspan structure is required to carry the basic aircraft loads to a few columns. Following study of numerous prefabricated and site fabricated structural systems, a locally shop-fabricated steel truss system was selected as being the most practical and economical. Though a 2-way truss system is theoretically more structurally efficient, ease of fabrication and the necessity to provide easy access for piping and ductwork may favor a one-way system.

The deck surface is proposed as consisting of modular steel panels bolted to the trusses. Various special panels, housing lights, fueling hydrants, fire extinguisher nozzles, and other services would be produced, and would be interchangeable with the standard panels to facilitate the constant upgrading and updating of flight deck mechanical systems. The same panel system, applied to a short-span structure over a shallow pit, would serve for ground-level flight decks. The VTOL-aircraft are assumed to carry skids, not wheels, as landing gear, to save weight and maintenance, and to spread landing loads on the deck, allowing a lighter deck structure. At maintenance bases, wheeled dollies would be used to maneuver the aircraft.

With regard to noise reduction, the deck can serve several functions. The most effective means of reducing noise transmission from the deck to a surrounding urban area is to interpose a solid barrier to cut line-of-sight contact between the aircraft on the deck and the area affected:

an upturned, solid edge of the deck, an adjacent building, or the terminal building itself. Once this is done, a further reduction may be accomplished by making the deck sound absorptive, thus helping to prevent noise buildup by multiple reflections. A suggested means of doing this is shown in the accompanying diagram. Holes of about two inch diameter, constituting up to twenty per cent of the deck surface, admit sound waves to the area below the deck, where they are absorbed by thick mineral batts. The effectiveness of such an arrangement, although theoretically fairly good, is in need of further testing and refinement before it can be recommended for general adoption.

By mounting each portion of the deck on only four columns, it is possible to insert cushioning devices at the bearing points to attenuate noise shock and vibration which might otherwise pass from the landing aircraft to the terminal below or adjacent.

The question of lighting the flight deck is in need of further research. A variety of options are possible: overall high-intensity illumination, selectively placed marker lights electroluminescent patterns on the deck surface, variable patterns of marker lights to assist in maintaining an optimal

approach path, and variable types and intensities of lighting for varying conditions of weather and visibility. Selection of the best lighting system awaits operational testing under bad weather approaches to the deck. It is intended that blind approaches be made to a hover point 50 feet above and off the edge of the flight deck, from whence a visual air taxi and landing proceduring would be performed using the lights.

The projected all-weather capability of the VTOL system is based in part on the premise that the relatively small area of a VTOL flight deck can be weather-controlled in ways that a CTOL airport cannot. This weather control can largely be incorporated into the flight deck structure.

Water falling on the dead-level deck surface will immediately drain through the holes in the deck to the truss space below, where it will be caught by a system of sloping sheet metal panels and channels. Spilled fuel can be separated from the water where the channels drain into vertical risers.

Snow removal can be accomplished by several means. If tractors are used, the snow can be pushed either to a steam melting basin, or to a chute which will conduct it to trucks

or barges waiting below. A more satisfactory system, however, would be one which would melt the snow at the surface of the deck as it fell, thereby keeping the deck open for operation and free of service vehicles at all times. Figure IV.8 illustrates how a snow melting system might be integrated with the other components of the flight deck system.

The steel cells of the deck panels serve as ducts for the passage of hot air beneath the surface of the flight deck. The heated air is supplied from either gas-fired furnaces or steam-air heat exchanges suspended in the truss-work beneath the deck, and is distributed to the deck cells and returned from them to the heat source by large main ducts which are connected to feeder holes in the individual cells. This hot air system was adopted after trial designs based on direct steam, hot water, and electric melting systems were discarded because of the cost of the materials and the complexity of the connections involved in their implementation. An estimate of its fuel cost per pad per year, based on gas as the source of heat, is as follows:

Rate of fall is assumed as $\frac{1}{2}$ " per hour maximum
at a density of 0.25 and an average temperature
of 15° F.

$$T = 32^{\circ} - 15^{\circ} = 17^{\circ} \text{ F.}, \text{ or } 9 \text{ BTU/lb.}$$

$$\text{Heat of fusion} = 153 \text{ BTU/lb.}$$

$$\begin{aligned} & 1/24 \text{ ft}^3/\text{hr}/\text{ft}^2 \times 0.25 \times 62.4 \text{ lb}/\text{ft}^3 \times 153 \text{ BTU/lb} = \\ & 100 \text{ BTU}/\text{hr}/\text{ft}^2 \end{aligned}$$

If deck is 140' x 140' for each gate position,

total area per gate is 19,600 ft²

Assuming 50% efficiency in conversion of fuel to melting energy,

$$? \times 100 \text{ BTU}/\text{hr}/\text{ft}^2 \times 19,600 = 3,920,000 \text{ BTU}/\text{hr.}$$

or about 8×10^6 BTU/inch of snow during maximum rate of fall.

To melt 60" total snow per winter,

$$60 \times 8 \times 10^6 = 4.8 \times 10^8 \text{ BTU}/\text{gate}/\text{year}$$

The cost of gas in Boston in 1968 was approximately

\$1.40 per million BTU's, making annual fuel cost

$$\text{per pad } (4.8 \times 10^8 \text{ BTU}) \times (\$1.40/10^6 \text{ BTU}) = \$672$$

Initial cost per pad to install 5,000,000 BTUH of

gas heat per pad, along with the associated fans

and ductwork, is estimated conservatively at

\$75,000. Maintenance costs would not exceed

a few hundred dollars per pad per year.

The steam-air heating system, perhaps safer in the presence of aircraft fuel, is assumed to cost roughly the

same to install and operate.

Fog dispersal would seem to be technologically feasible for a VTOL flight deck because of its relatively small area. Dispersal devices, depending upon their exact configurations, might be installed as flush inserts in special deck panels, or as peripheral attachments.

Services required of the flight deck by the aircraft itself include recessed connections for refueling, water, air conditioning, waste disposal, and communications. Special deck panels could contain all these services, and the associated piping and ductwork could be accommodated in the open trusswork below. Fuel storage could be in subterranean tanks, in surface tanks placed in protected locations, or in barges at over-water VTOL airports. Fuel deliveries by pipeline, railway, truck, or barge must be accommodated in the design of the site.

A topic worthy of special study is that of protection against crash and fire on the flight deck. It should be possible to develop both special fire-resistant escape devices and automatic fire control systems for this relatively small area. It is not necessary to provide access for fire trucks to the deck, since fire fighting equipment can be installed

to cover each landing pad.

The final requirement for the flight deck system is that it should provide in its trusswork catwalks and sufficient head clearances so that maintenance personnel may reach any point in the complex network of pipes, wires, and ducts .

G. Parking Accommodations.

The specific requirements for parking of private autos at a given site are very uncertain. The percentage of passengers using private automobiles for airport access can vary quite widely. For a major suburban site, most passengers are likely to use private auto; for a major city-center site, most passengers are likely to use taxi; at sites where transit is available, especially where it is closely linked to the metroport concourse, there could be considerable usage of this mode of access. The actual requirements will be determined by the characteristics of each site, the type of traveller using the site, and the metroflight service offered, which could vary during the site's lifetime.

Parking space requirements are also affected by trip

duration. Assuming that metroflight service will attract a large number of one-day business trips, and that even half-day trips will become possible, the duration for metroflight trips should be shorter than that for conventional airtrips, thereby reducing parking space requirements in terms of autos per daily or peak hour passenger.

It is envisaged that intermediate floors in an elevated deck structure would be used for parking. The parking floors could, however, be below grade at some sites, at a certain cost penalty (see Appendix). Keeping modular expansion of the metroport in mind, this creates a requirement for sufficient parking space below each individual landing pad to handle the demand generated by that pad, and this will determine the number of floors of parking required, and therefore the overall metroport height.

Providing space for 500 cars per pad would require roughly 200,000 sq.ft. of parking space. If the parking area under each pad is 150 x 300 feet, then roughly four floors of parking would be required. Whether this is sufficient depends very much upon the particular site.

Because of this uncertainty, it may be wise to adopt different strategies in planning parking space for various

sites. In certain downtown locations, it may be wise to add more floors and space to the metroport which may be used for parking if the need develops, but which can be used for non-metroport parking or converted to other commercial activities if it is not required. At suburban sites, it would be wise to consider acquiring options on nearby land which can be used for a parking lot, or an additional parking garage if the need develops as metroport activities increase and new direct services are added. For a suburban site where the pads are elevated over the intersection of two expressways, one can envisage using the land inside the loops of the cloverleaf pattern for such parking facilities. This adjacent parking should be linked to the metroport by a moving sidewalk or conveyor if the walking distances are too great.

H. Access Roadways

For any major metroport, one of the major cost components will be elevated access roadway structures which link the building with surrounding expressways and roadways. These should be designed to avoid congestion appearing on the surrounding roadways from traffic flows

into the building at peak times. Multiple entry to the site should be provided, and separate access provided for the parking floors. Special care should be taken to ensure that entry to the parking areas is fast enough to avoid the formulation of queues which block access roadways. Toll gates should be placed on sections of each floor of parking rather than on the access roads into the building.

Chapter V.

Ten Evolving Studies in Metroport Design

The metroport designs illustrated in this chapter represent a progression of ideas which developed over nearly two years' time. It will be noted that the progression is generally toward simpler, less costly, more efficient buildings, and that the last designs are radically different from the first. The last (Studies 8 through 10) are presented as viable alternatives to be considered in the implementation of a VTOL metroport network and in the establishing of standards for future VTOL metroports. The first seven are presented, together with the work by others described in Chapter III, to illustrate the alternatives which were tried and rejected. The intent is to provide a comprehensive background for future metroport planners, by documenting the problems encountered, the tentative solutions proposed, and the evolution of these solutions.

The tabular statistics included with each design are intended to provide some basis for comparison of the relative costs and efficiencies of the various schemes. The

cost figures are for the schemes as drawn. The apparent unit cost fluctuations from design to design are accounted for by the widely varying amounts of space for offices and for service functions that are provided in the designs. The actual amounts of office and service space required would be determined by local conditions.

A. Study # 1: Boston Vertiport, January 1969

Description

Boston Vertiport was the first total design for a VTOL terminal produced under this project. Its location was assumed to be a large railroad yard adjacent to downtown Boston, Massachusetts, but the scheme was intended to be applicable to other sites, both over land and over water. The fundamental structure is a steel trussed flight deck supported on widely spaced columns with parking and terminal functions housed on numerous semi-independently supported floors beneath the deck. Ground transportation interfaces with the terminal at an intermediate level, and most passenger movement within the terminal is vertical, by means of escalators and elevators.

The design shows six aircraft gate positions in two

staggered rows, with linear expansion envisioned for the future. Aircraft navigate to a grid lighting system adjacent to one row of pads or the other, then air-taxi over a sloping noise baffle and settle into the proper gate positions. The extra half-pad at the end of each row is provided to allow a disabled aircraft to be parked outside the space required by normal metroport activities.

Freight and mail enter and leave the terminal at ground level, with several floors above allotted to parking. The highest full floor is given to access for private automobiles, taxis, buses, and the Boston subway. It functions as a one-way traffic loop, with pickups on one side and dropoffs on the other. Short-term parking is provided. The level above, the main concourse, is similarly split between arriving and departing passengers. Here tickets are bought, baggage is checked or retrieved, and various concessions are at the disposal of the passenger. In order to proceed to the mezzanine above, he must pass an automatic gate which is opened by the insertion of a valid ticket. The mezzanine serves as a waiting area and as a connecting area for transferring passengers. Once a flight is called, the passenger rides a set of escalators to a boarding lounge, from which he

enplanes through telescoping walkways. His baggage, meanwhile, has risen from the concourse on a sloping conveyor, and has been moved longitudinally to the proper gate position by an automatic system one level above the mezzanine. There it is stored within the truss space until it can be loaded on the plane. The suitcases of a transferring passenger are shifted from one gate to another entirely at this level, and the luggage of arriving passengers is sent down to a conveyor to a claim area on the arrivals side of the concourse.

An important feature is the end structure of the terminal. At its lowest level it contains truck and rail docks, a receiving room, and entrances to freight elevators, one of them large enough to carry service vehicles to the flight deck. On its intermediate levels are housed the offices required by the airport administration and the various airlines. Freight and mail are handled at the level of the bottom of the flight deck trusses. At deck level, vehicular access and flight deck operations space are provided. Above are a restaurant, an observation deck, and a control tower.

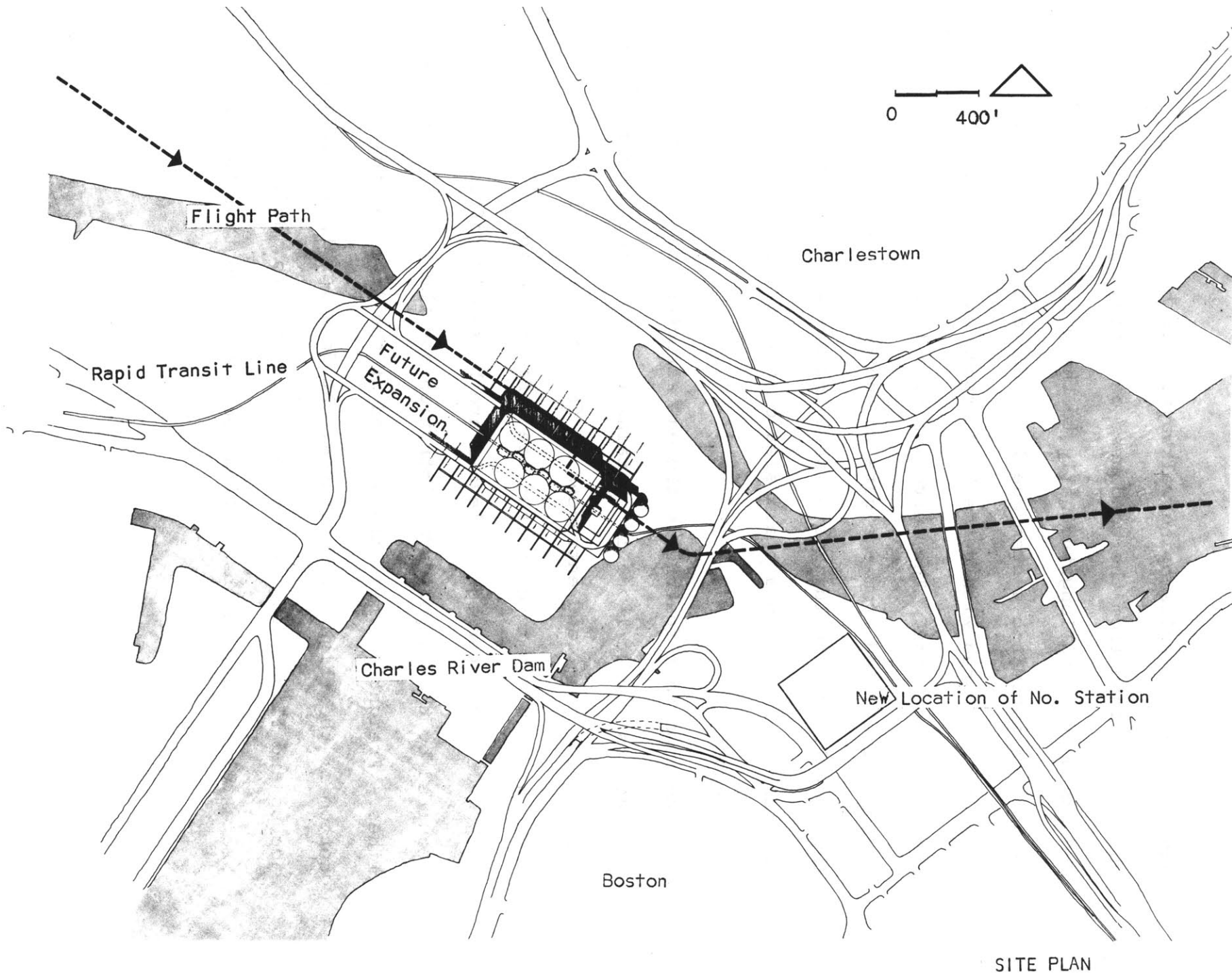

Fig. V-A.1 Location for Boston Vertiport

SITE PLAN

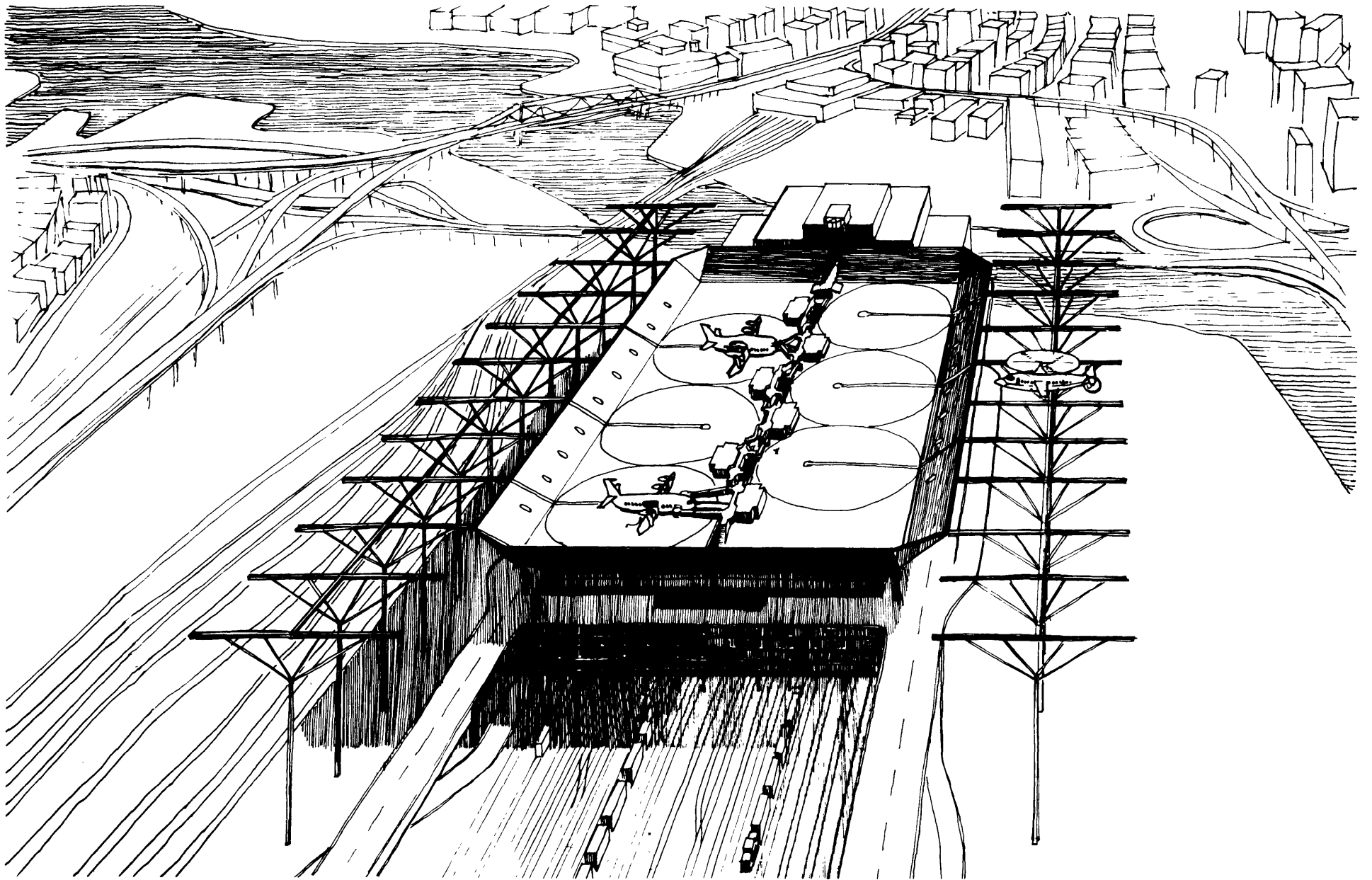

Fig. V-A.2 View on 15° Approach to Boston Vertiport

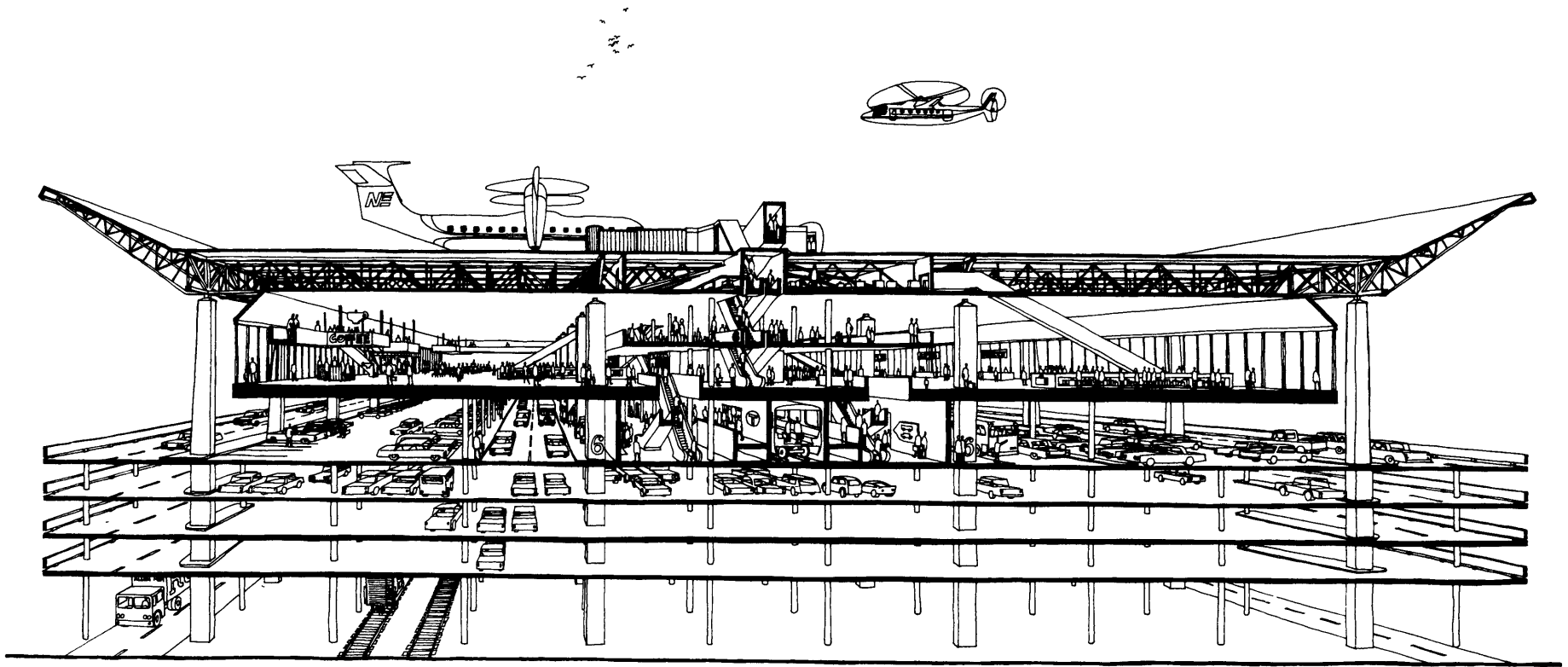

Fig. V-A.3 Cross-Section of Boston Vertiport

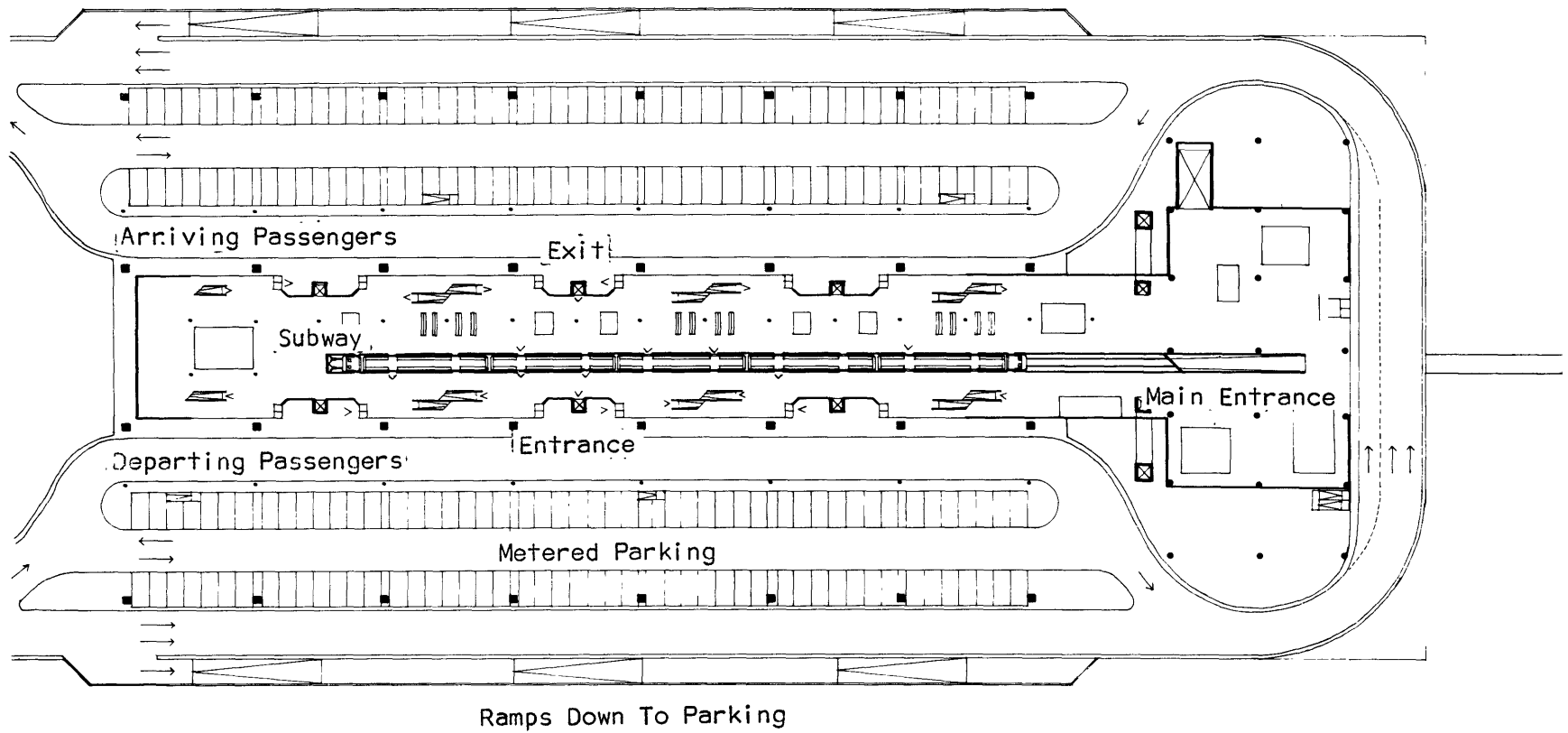

Fig. V-A.4 Plan View - Vehicular Arrival and Departure Level

0 100 200

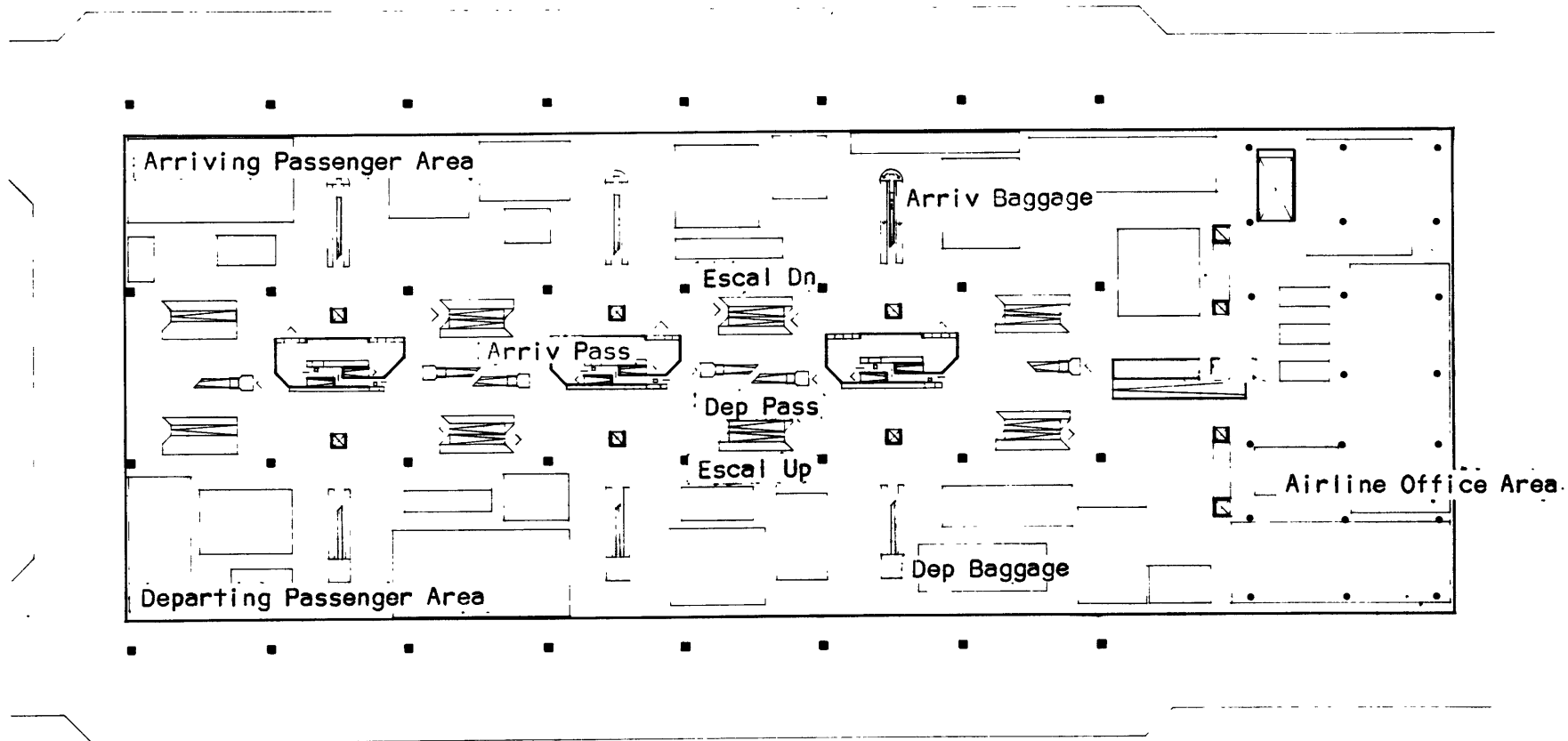

Fig. V-A.5 Plan View - Passenger Concourse Level

0. 100. 200.

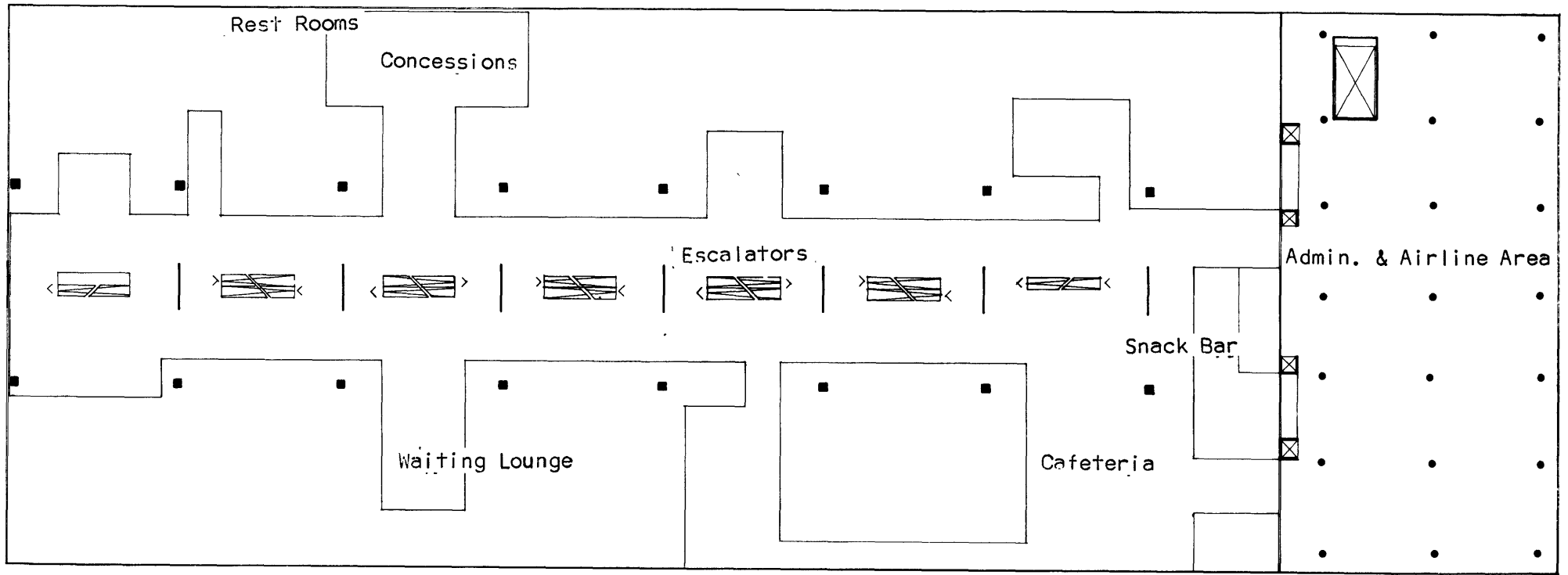
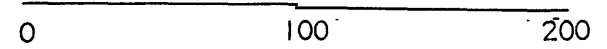

Fig. V-A.6 Plan View - Passenger Mezzanine Level



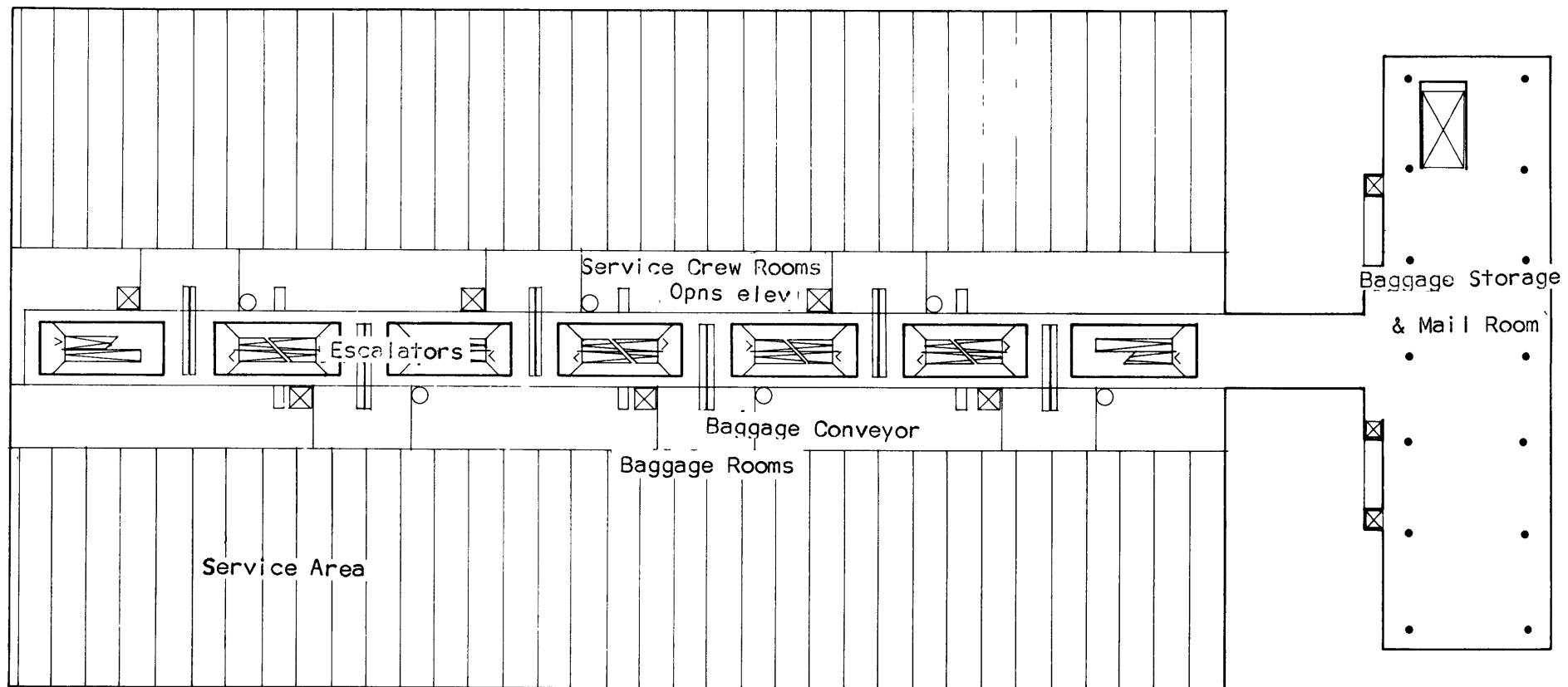

Fig. V-A.7 Plan View - Inside Deck Level

0 100 200

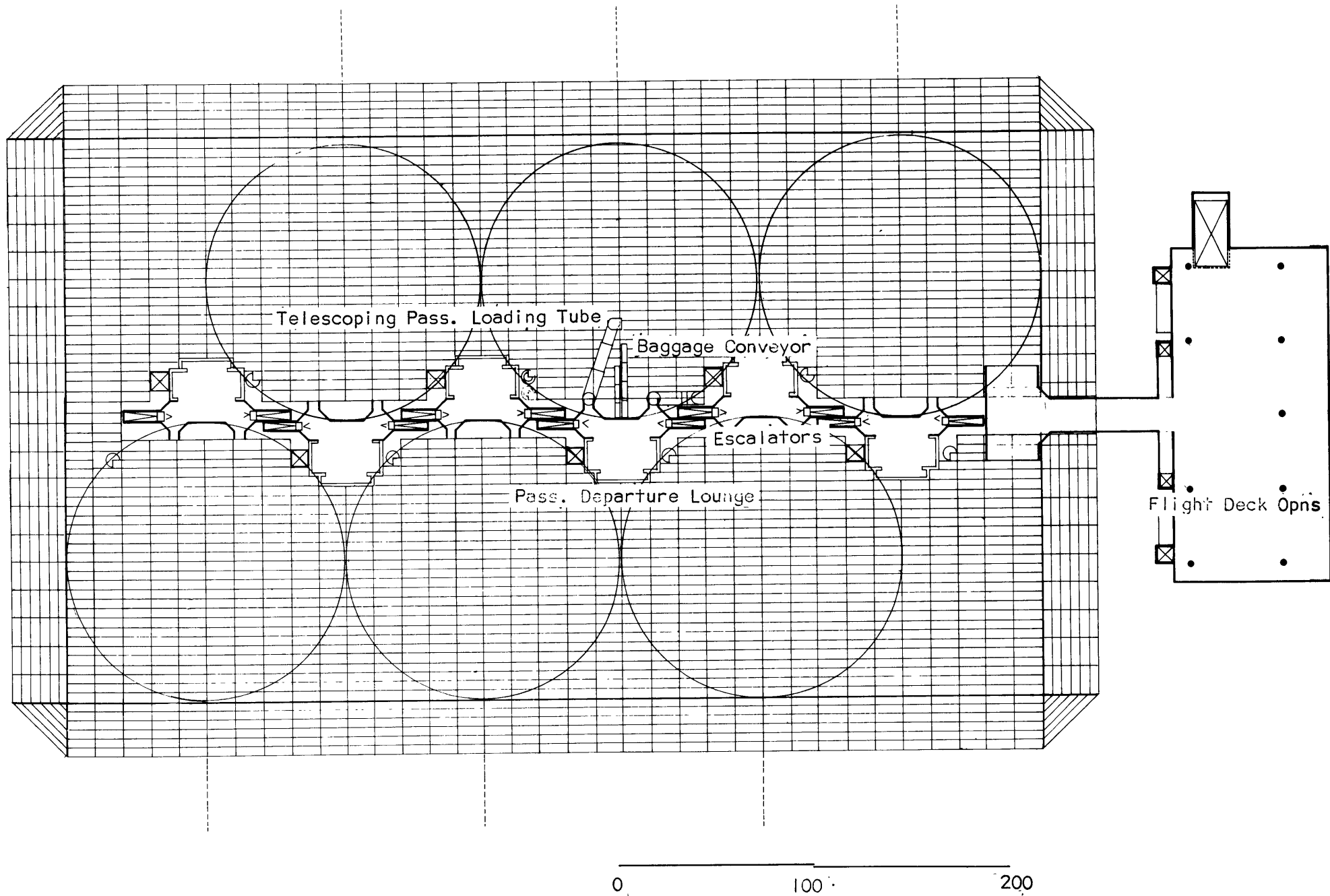

Fig. V-A.8 Plan View - Deck Level

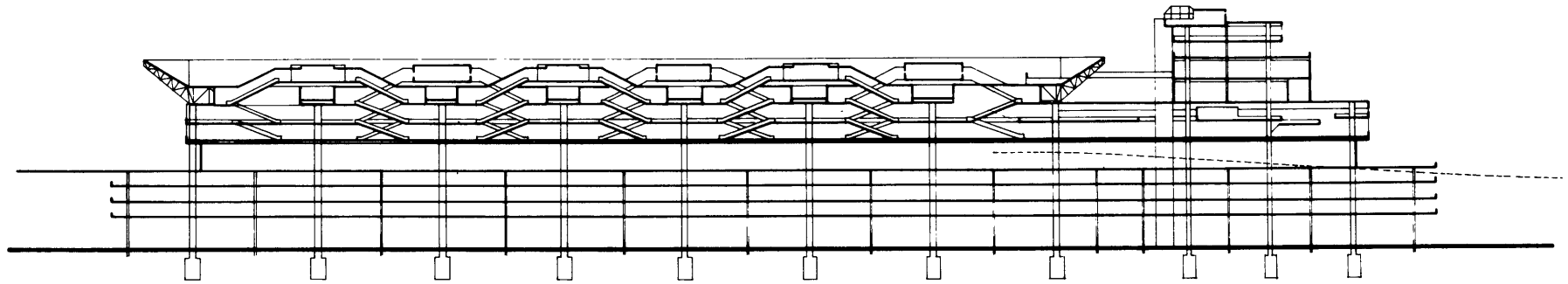

Fig. V-A.9 Longitudinal Cross Section- Boston Vertiport

Evaluation

The major drawback of this design is its complexity. Though little walking is required of the passenger, he must traverse numerous vertical levels between his ground transportation and his flight, and he must make a relatively large number of path-selection decisions during this process. Much of this complexity resulted from a decision to base the terminal design on a non-reservations passenger processing which allows one to defer payment for the flight until after the flight is completed. Though this system would be of value to the last-minute passenger, by saving a minute or two of pre-flight formalities, it was subsequently judged to be far too costly in terms of the architectural and operational complexities it would cause. It also provides a good example of how closely the metroport design is tied to the assumed passenger processing system. The design is further complicated by having its diverse functions too strictly segregated, each on its own floor level.

The design also suffers from a lack of balance in the sizes of several of its areas. The concourse level is larger than required, especially on the arriving side,

while the surface transportation facilities a level below are crowded. At least one additional dropoff lane needs to be provided, and the direction of traffic flow must be reversed in order to allow passengers to enter and leave vehicles on the proper side.

A third primary disadvantage is the passenger's lack of visual contact with the aircraft. He is unable to see his vehicle except in passing from the escalator to the telescoping walkways, and is therefore deprived of both a potential orientation-giving device in his journey through the terminal, and an important part of the excitement of making the trip.

Finally, the complexity of the design results in an unreasonable cost of construction and operation. The numerous escalators, costing \$50,000 per escalator per flight, are prime contributors to the expense.

Land required per gate position: 117,000 sq.ft.

Flight Deck area per gate position: 26,250 sq.ft.

Enclosed public area per gate position: 46,000 sq.ft.

Average distance curb to aircraft: 450 feet
departing: 450 feet

Level change curb to aircraft: departing: ascend 50 ft.
arriving: descend 50 ft.

Construction cost per gate position, exclusive of parking and equipment (May 1970 dollars): \$3,480,000.

B. Study #2: The Drive-Through Scheme

Description

In this design, the metroport is a modular design which is expandable by one or two pad modules at a time. The number of passenger processing levels have been reduced from five to three, and more curb space has been provided by arranging for transverse driveways through the terminal. (For this and subsequent designs, the descriptive drawings use the graphic symbols for departure and arrival passenger paths, ticket counters, elevators, etc. as shown by figure V-B-1).

From the plan views shown in figure V-B-2, the departing passenger (shown by the dotted path) enters from the drop-off curb directly into a ticketing lobby where he buys a ticket, deposits his bag, and ascends an escalator to a longitudinal main concourse which connects all ticketing lobbies, and contains concessions and waiting areas. From here he can see the aircraft on the flight deck through a large clerestory window. At boarding time passengers only are allowed to ascend another escalator to a final gate lounge area. The transferring passenger need not descend beyond the concourse level.

Baggage is raised from the lobby and parking levels to the roof of the main concourse, where it travels longitudinally to the correct gate for storage until flight time.

An operating procedure is envisioned whereby each gate lounge serves a pair of aircraft. Each aircraft is attached by telescoping walkways to two lounges, one for enplaning and one for deplaning. Alternate lounges are designated as enplaning or deplaning lounges, and a one-way, non-interfering flow of departing (or arriving) passengers is created within each lounge.

In its overall configurations the terminal consists of an end structure plus either one row or two mirror-image, back-to-back rows of these pad modules. See figure V.B.3. In either case, ground traffic follows a basic one-way loop with transverse driveways between the modules.

Analysis:

The passenger in this scheme finds himself subject to two sorts of confusion. The first occurs as he approaches by automobile, when he must choose which transverse driveway to enter. If he is alert he will be guided to his proper driveway by large visual displays; if not, he may

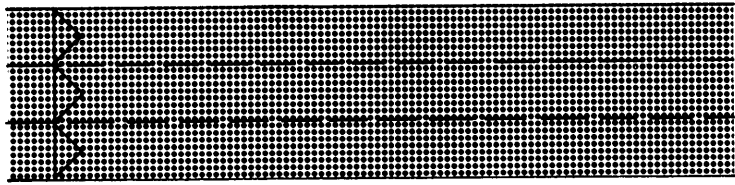

ROAD



DEPARTURE



ARRIVAL



INFORMATION



TICKETING

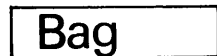

BAGGAGE CHECK



BAGGAGE CLAIM



TICKET CONTROL



ELEVATOR



STAIR, ESCALATOR

Ofc
Admin
Conces

AIRLINE OFFICES
ADMINISTRATION
CONCESSION

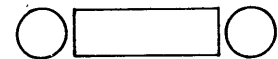

PASSENGER BRIDGE

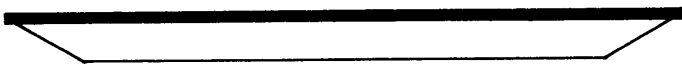

FLIGHT DECK, SECTION

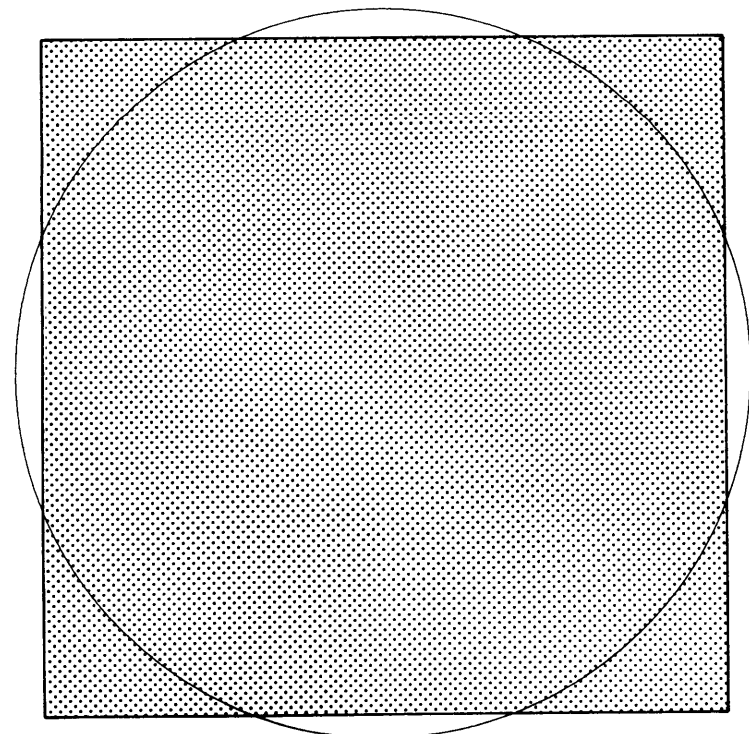

SCALE 100 FEET

FLIGHT DECK, PLAN

Fig. V-B.1 Graphic Symbols for Drawings

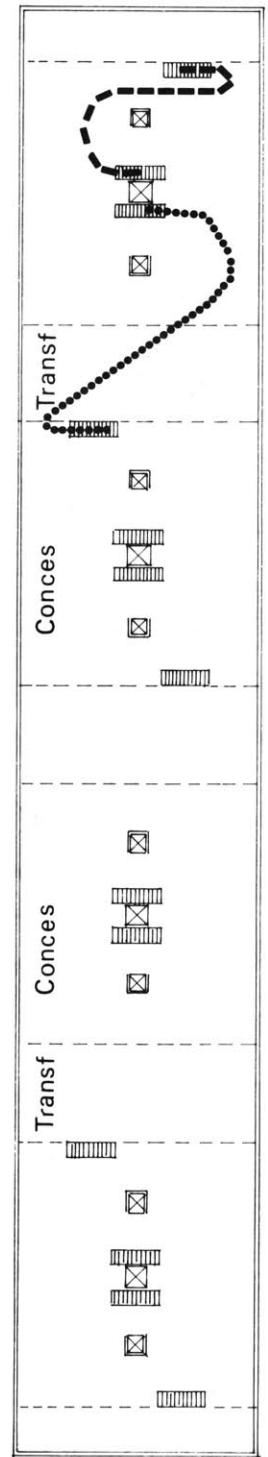
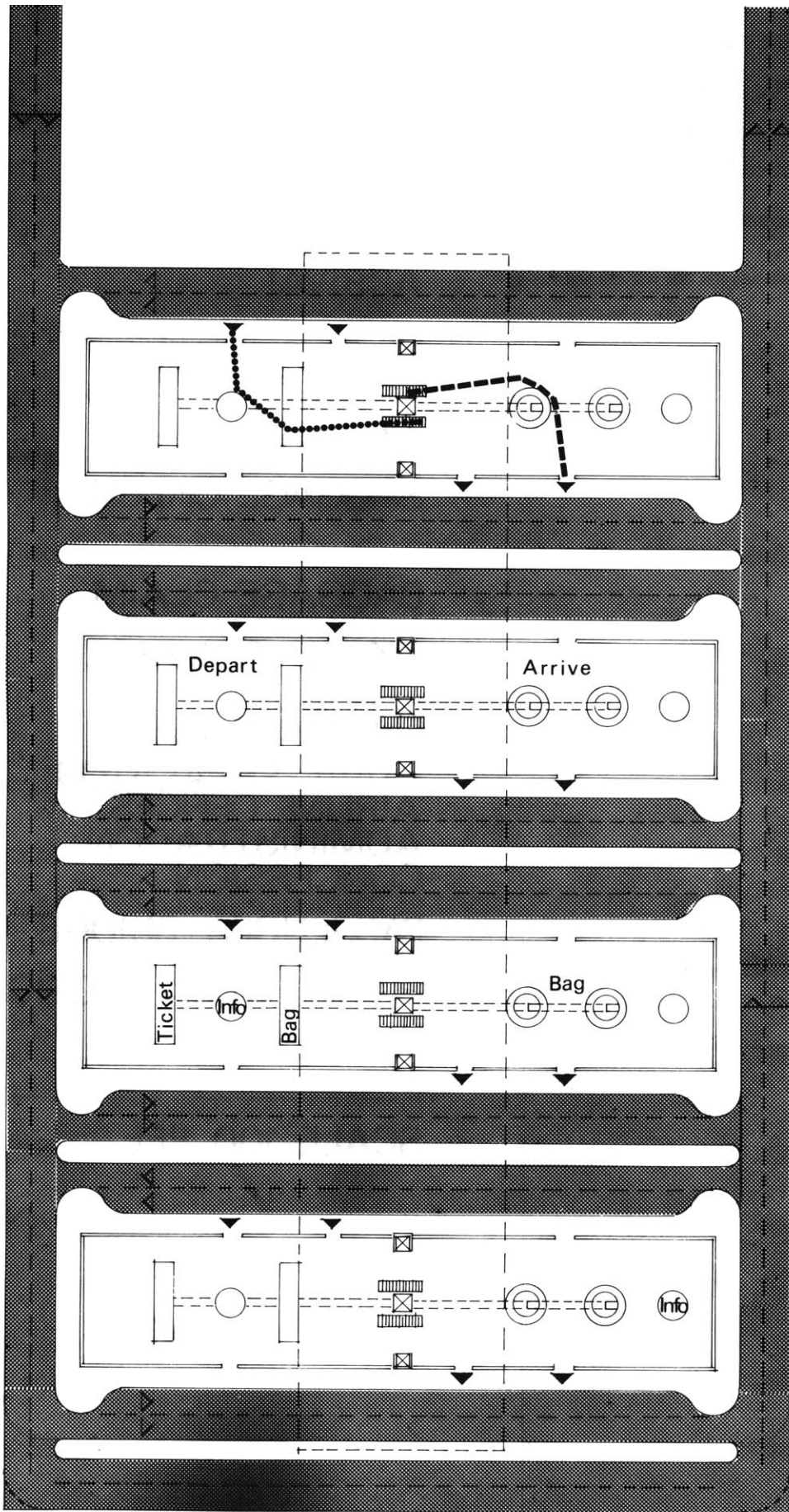

1 Depart Arrive

2 Transfer

Fig. V-B.2. The Drive Through Scheme: Floor Plans Levels 1 and 2.

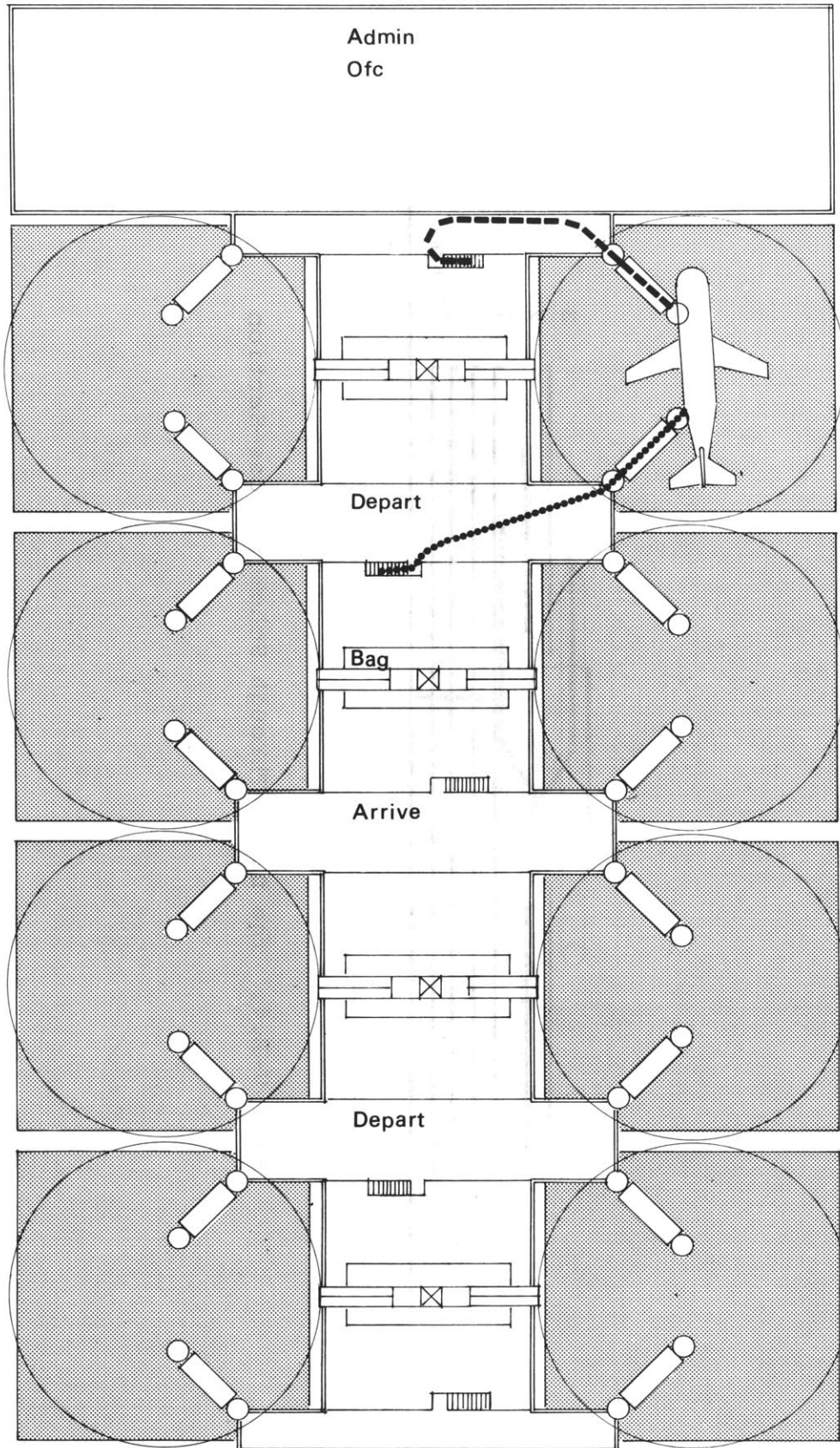

3 Deck



Fig. V-B.3. The Drive-Through Scheme: Floor Plan Level 3

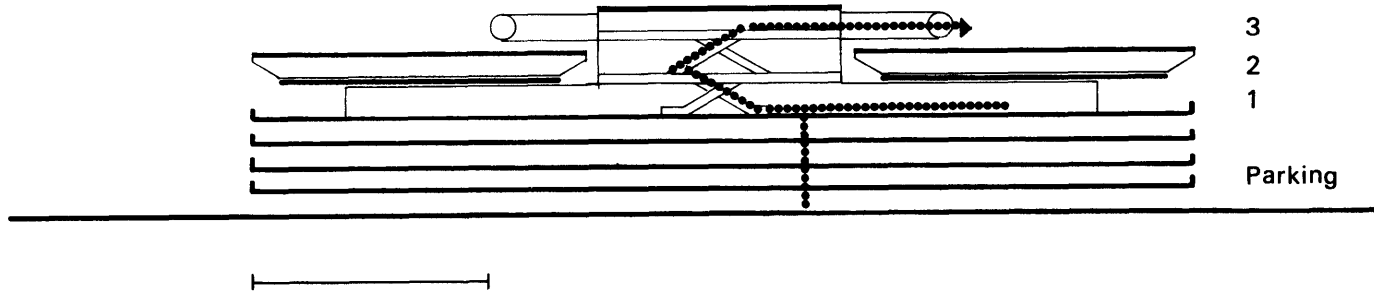

Fig. V-B.4. The Drive-Through Scheme: Cross-Section

enter the terminal at any driveway, and there purchase his ticket, with the penalty that he often must then walk some yards to the proper boarding lounge when he reaches the concourse level. In practice, this would very likely mean that many drivers would simply not try to drive directly to the proper gate, but instead would turn into the first uncrowded driveway, thereby putting an excessive load on the first gates of the terminal.

The drive-through idea also results in the passenger's having to follow a rather tortuous route through the metroport. A number of right-angle turns are required of him, and it is not always obvious from the architecture which way he should turn. A straight-line path would be much preferable, in order to avoid this second sort of confusion.

The numerous road turnoffs and blind corners raise a question of traffic safety; rumped left fenders and rear-end collisions would probably be relatively frequent in a scheme with such complex traffic patterns.

Noteworthy aspects of the scheme are its modular building-block feature, the reduced number of levels, and the visibility of the flight deck from the concourse. In these respects the design is a considerable improvement over its predecessor.

Land required per gate position: 35,000 sq. ft.

Flight deck area per gate position: 19,600 sq. ft.

Enclosed public area per gate position: 24,300 sq. ft.

Average distance curb to aircraft: arriving: 450 ft.

departing: 450 ft.

Level change curb to aircraft: departing: Ascend 30 ft.

arriving: Descend 30 ft.

Construction cost per gate position, exclusive of

parking and equipment (May, 1970 dollars): \$1,818,000

C. Study #3: The moving Sidewalk Scheme, December, 1969

Description

Using a deck arrangement similar to that of Study #2, it is possible to conceive of a terminal which would be built in a situation such as that over a pier, where curbsapce could be provided only at the end of the building. In such a case, passenger processing would take place in the end structure of the terminal. Since walks up to 800 feet would be involved to reach the fourth gates for an eight pad metroport, moving sidewalks are installed to transport the passenger from the ticketing concourse to the various stairs or escalators leading to gate positions.

Analysis

Moving sidewalks have not proven to be satisfactory in practice. They are slow, and they clog quickly with riders, yet getting on and off is sufficiently risky that many passengers prefer to walk rather than ride. They serve here as a crutch to support a basically unwieldy design. Aside from this objection, passenger flow is rather straightforward and easily understood. Curbspace as shown is wholly inadequate for the demand created by eight gate positions.

Land required per gate position:	35,000 sq. ft.
Flight deck area per gate position:	19,600 sq. ft.
Enclosed public area per gate position:	16,100 sq. ft.
Average distance curb to aircraft:	360 ft. walking +280 ft. riding
Level change curb to aircraft:	departing: Ascend 30 ft. arriving: Descend 30 ft.
Construction cost per gate position, exclusive of parking and equipment (May, 1970 dollars):	\$1,543,000

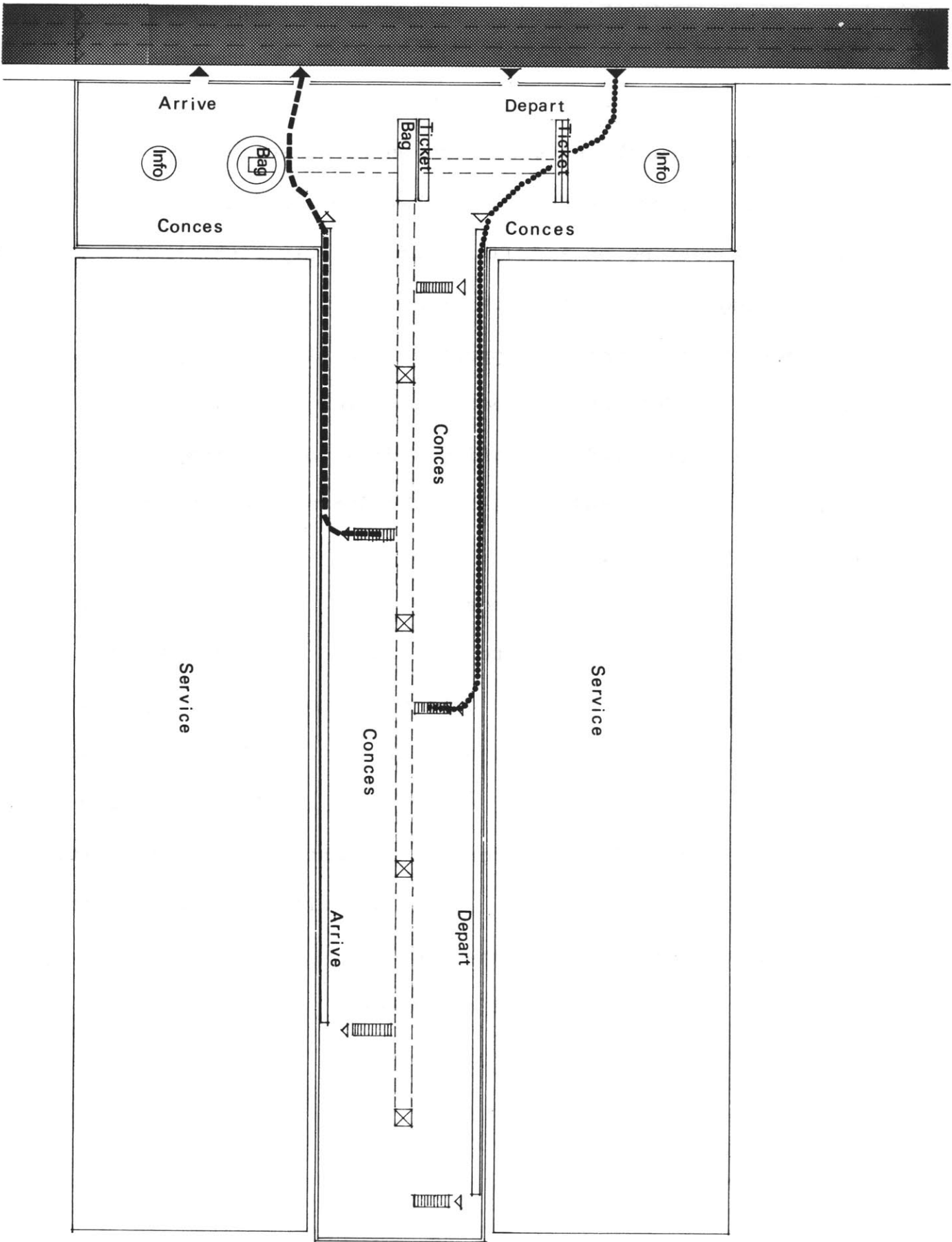

1 Depart Arrive

Fig. V-C.1. The Moving Sidewalk Scheme: Main Floor Plan
(for deck level plan, see fig. V-B.3)

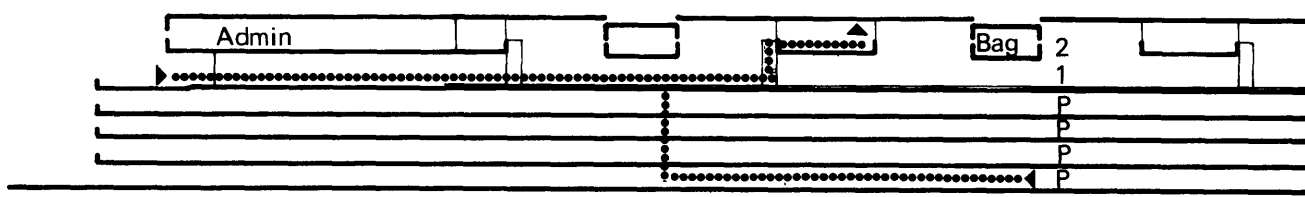
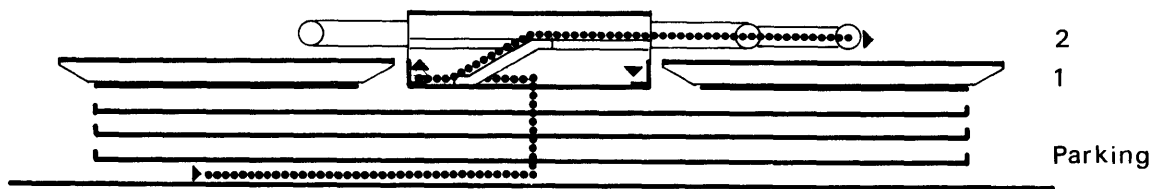

Fig. V-C.2. The Moving Sidewalk Scheme: Cross-Section and Longitudinal Section.

D. Study #4: The Elevator Lounge Scheme, July, 1969

Description:

The most prominent feature of this design is that the gate lounges, two per gate position, are actually large elevators. By means of these devices the departing passenger can walk straight through the terminal from his automobile to his gate lounge, all on the same level, and can wait there in comfort for his flight. At the announced flight time, the doors of the lounge slide shut and the lounge is raised to a position above the pad level, where it connects to a telescoping boarding ramp. Meanwhile, the arriving passengers have deplaned into the second elevator lounge and are on their way down to the concourse. Arriving and departing passengers all use the same concourse, but their activities are separated horizontally in such a way that their main flows do not conflict.

Although this concept is basically an adaptation of the mobile lounge system in use at Dulles Airport, it has one additional feature: the passenger who just misses the departure of his lounge may take an escalator nearby to the upper level, where he may wait until the passengers in the lounge have boarded, after which he will be allowed to board. Deplaning passengers who are in a hurry can

similarly bypass the lounge on their way down. Transferring passengers need not go down at all, but may simply walk along the connecting skywalk to their next departure gate. Automatic passenger gates are programmed to allow transferring passengers and latecomers with reservations to enter the telescoping ramp from the skywalk on an equal priority with those who came by lounge, while latecomers without reservations are held back until last. Well-wishers and greaters are welcome to use the skywalk.

Concessions are arranged on a mezzanine above the main concourse, in order not to interfere with the main flows of passengers. Baggage is handled the same as in the preceding design, with the important exception that baggage can be checked at a machine within the elevator lounge, from which it is deposited in an underfloor storage space, from where it is automatically withdrawn and put on the aircraft after the lounge is raised.

The modular building-block feature of scheme #2 is retained, with all the flexibility that implies. Either a single row of pads or two rows back-to-back could be built, depending on site conditions. The end structure is kept as a basic part of the design. The upturned noise baffles seen at the edges of the flight deck on design #1

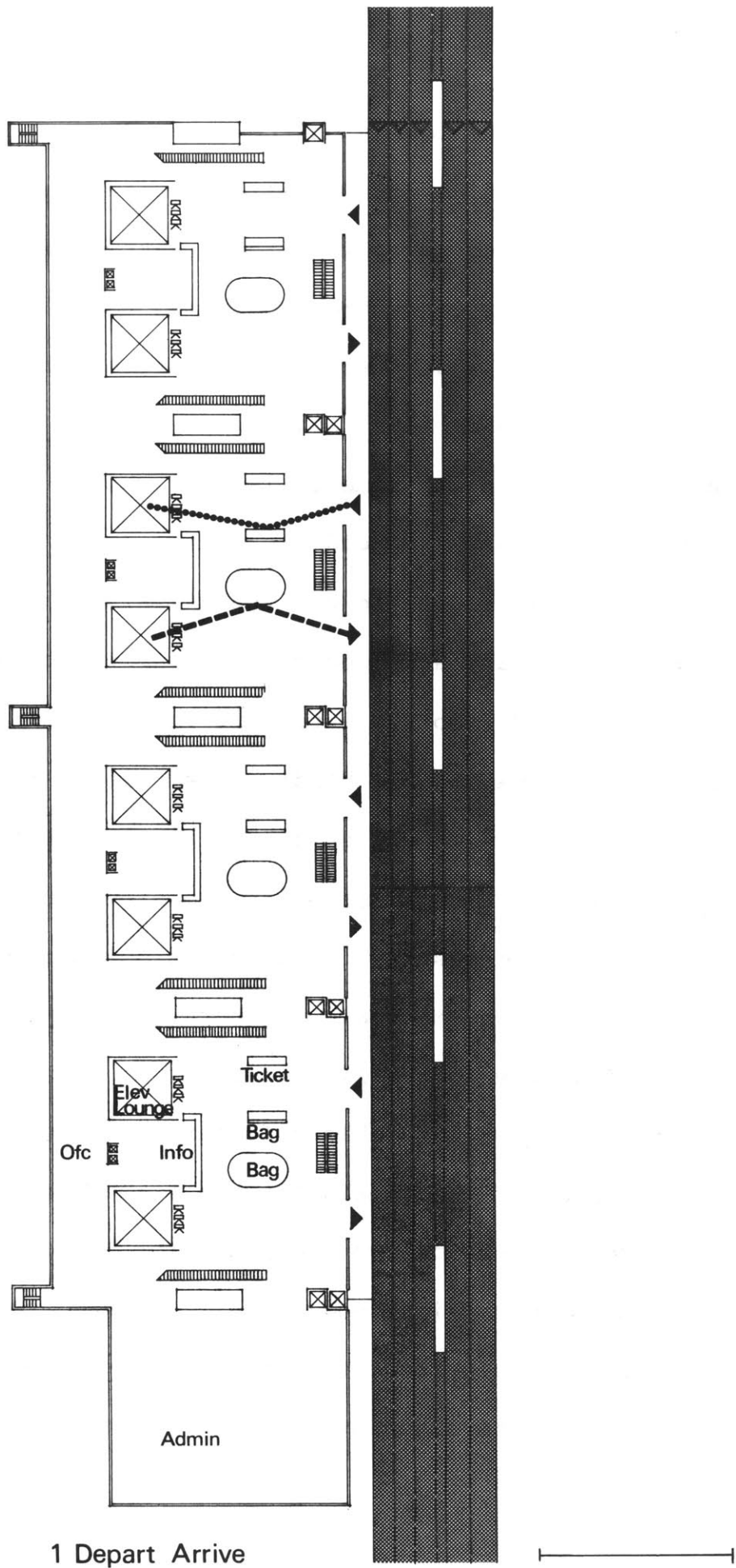

1 Depart Arrive

Fig. V-D.1. The Elevator Lounge Scheme: Main Floor Plan

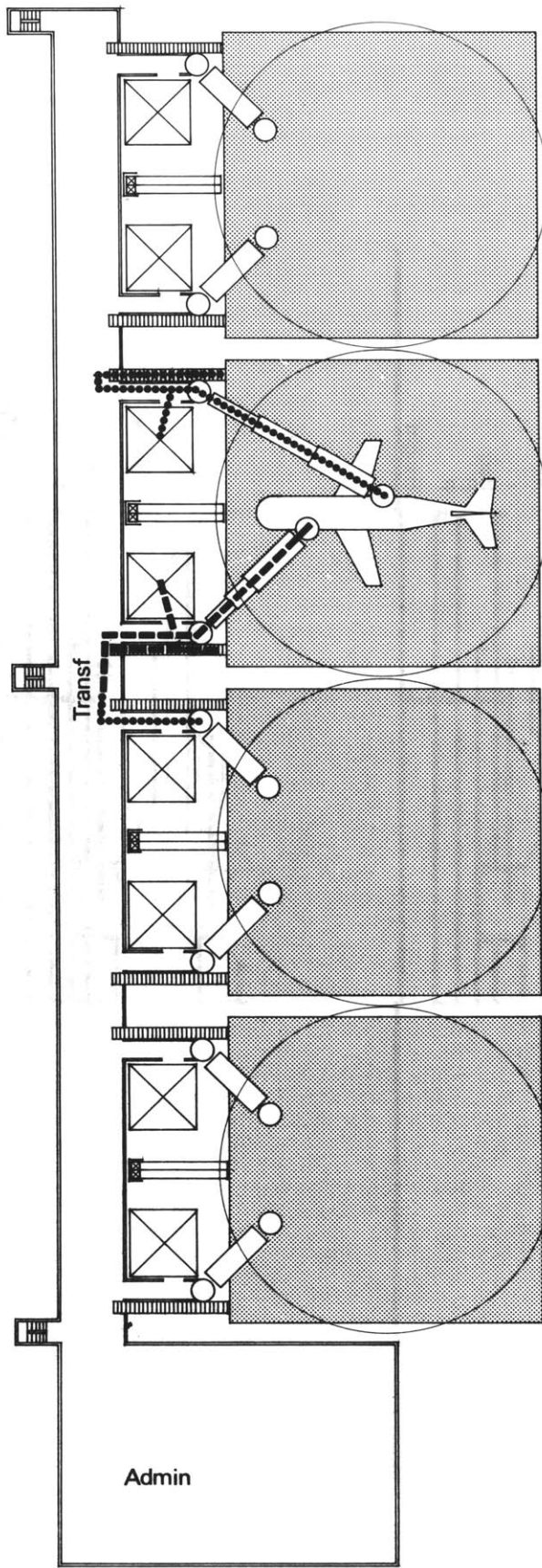

2 Transfer



Fig. V-D.2. The Elevator Lounge Scheme: Plan at Upper Level.

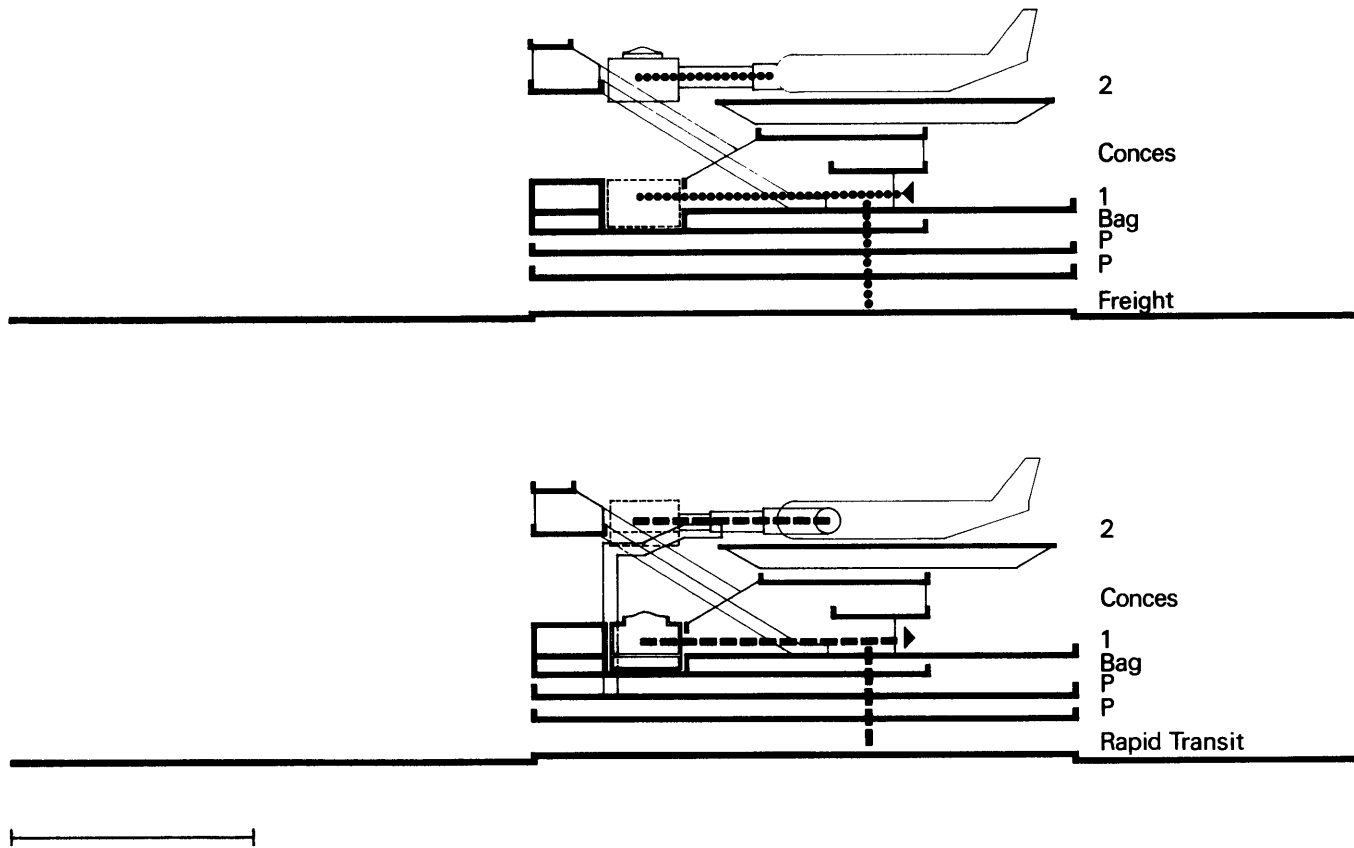

Fig. V-D.3. Elevator Lounge Scheme: Cross-Sections Showing Lounge Raised and Lowered.

would be a part of this design, as with any of the other designs, where local conditions required them.

Analysis:

The path to be followed by the passenger in this terminal is relatively short and uncomplicated, but it is achieved at tremendous monetary expense through the furnishing of a highly mechanized, highly redundant set of vertical people-movers. The economy of the scheme is especially questionable when one considers how many deplaning passengers are likely to bypass the elevator lounge and take the escalator down in order to avoid delay. It was consideration of this question, in fact, that led directly to the making of scheme #5, which follows.

The mezzanine concession area raises two problems. One is the question of whether concessions would be economically viable in this relatively hard-to-reach location, off the main routes of circulation. The other is that the required height of the flight deck above the concourse is increased by the mezzanine, causing additional expense in structural members, elevators, and especially escalators.

The single set of pickup and dropoff lanes will cause

problems with taxicab operations in many cities. Drivers generally prefer to drop off a passenger, then return to a queue to wait their turns to make pickups. This mode of operation would be difficult to enforce in this scheme.

Visual contact with aircraft operations is minimal in this design. The glassed-in escalators probably would be stimulating to ride, and the view from the skywalk would be excellent, but the concourse lacks any means of contact with the planes above.

Land required per gate position: 27,300 sq. ft.

Flight deck area per gate position: 19,600 sq. ft.

Enclosed public area per gate position: 24,000 sq. ft.

Average distance curb to aircraft: Departing: 230 ft.

Arriving: 230 ft.

Level change curb to aircraft: Departing: Ascend 50 ft.

Arriving: Descend 50 ft.

Construction cost per gate position, exclusive of

parking and equipment (May, 1970 dollars): \$2,170,000

E. Study #5: The Skywalk Scheme, August, 1969

Description:

By fixing the elevator lounges of scheme #4 in the raised position and taking advantage of the opportunities

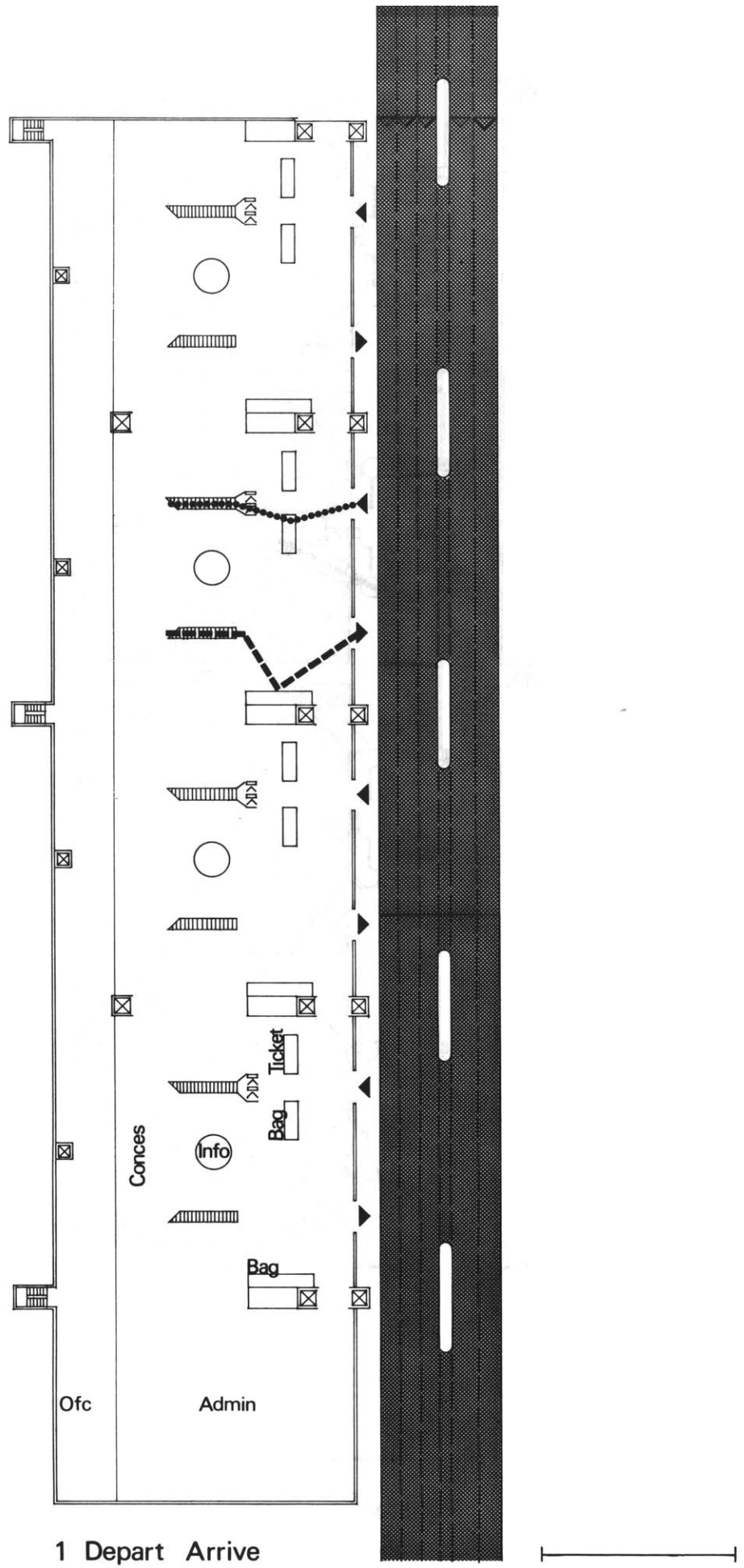
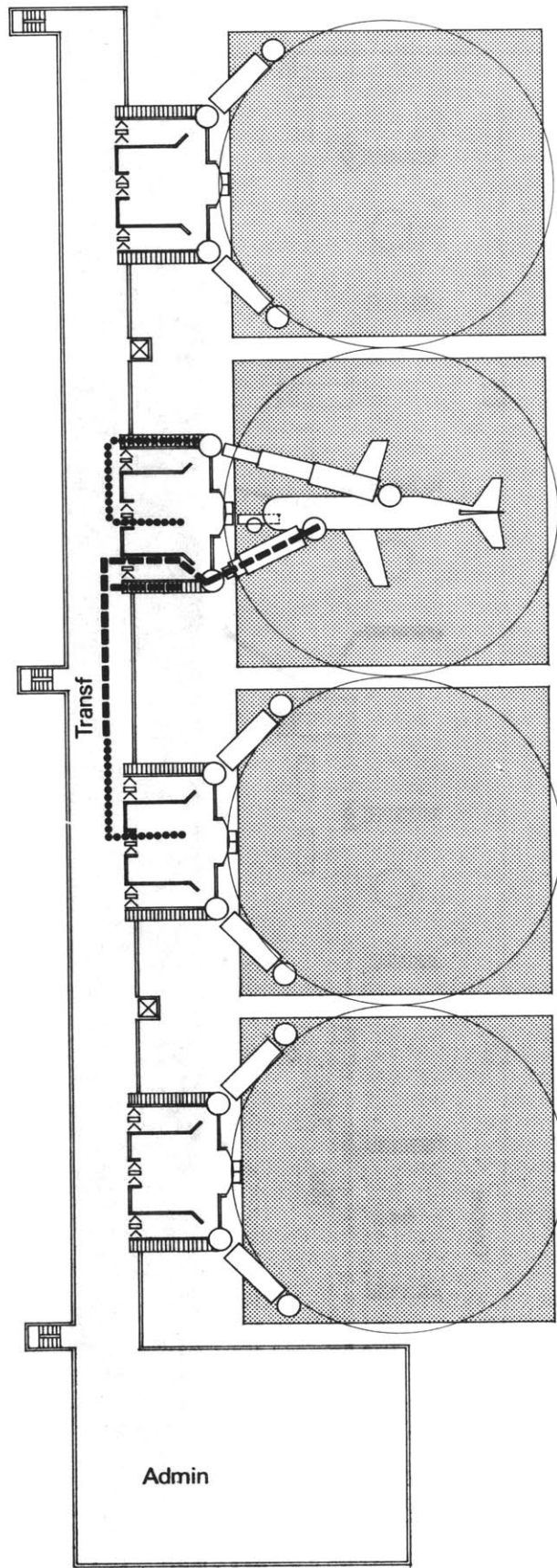

Fig. V-E.1. The Skywalk Scheme: Main Floor Plan



2 Transfer



Fig. V-E.2. The Skywalk Scheme: Plan at Upper Level

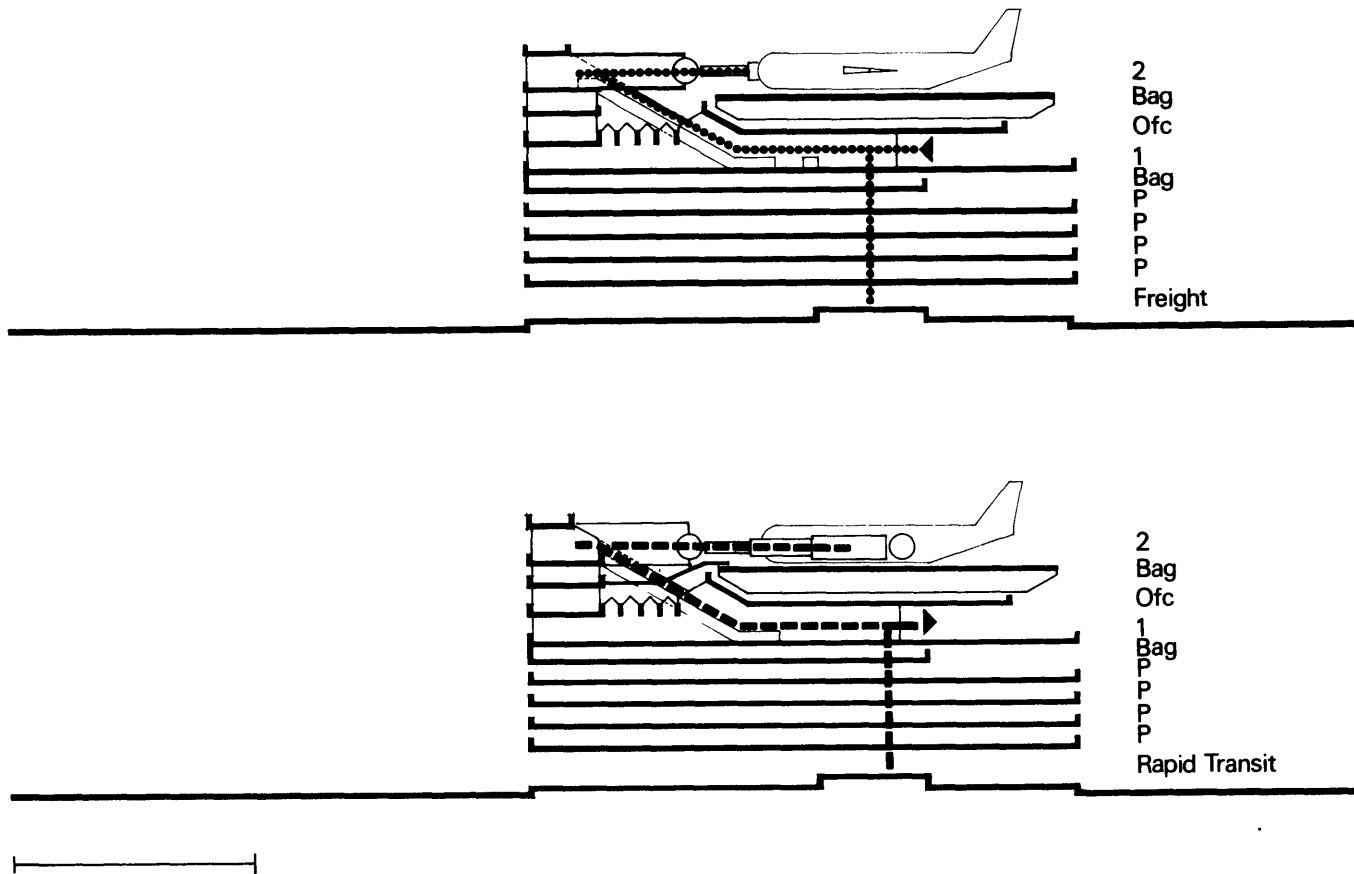

Fig. V-E.3. The Skywalk Scheme: Cross-Sections

this presents for spatial economies, the basic arrangement of scheme #5 was obtained. The mezzanine is eliminated in favor of placing concessions along the back wall of the concourse, allowing a considerable reduction in overall building height. The lounges are combined into one per gate position, with bypass corridors to allow deplaning passengers to exit without disturbing waiting enplaning passengers. The skywalk remains as a space for visitors and a convenient linkage for transferring passengers or passengers who come up the wrong escalator.

An important innovation in the concourse is the placing of ticket-baggage machines in a spaced row perpendicular to the flow of enplaning passengers. This allows the passenger to walk straight through the terminal to the escalator. It also allows the passenger who has waited in a queue for his ticket to continue toward the gate without having to fight his way back through the queue behind him.

Evaluation:

Most of the problems of study #4 are eliminated in this scheme, but several remain: the mixed taxicab dropoff lane, the lack of early visual contact with the aircraft. The task of the passenger in attempting to find his way

through the terminal is relatively easy nevertheless,
although not free of opportunities for error.

Land required per gate position: 27,300 sq.ft.

Flight deck area per gate position: 19,600 sq.ft.

Enclosed public area per gate position: 24,000 sq.ft.

Average distance curb to aircraft: Departing: 320 ft.

Arriving: 290 ft.

Level change curb to aircraft: Departing: Ascend 40 ft.

Arriving: Descend 40 ft.

Construction cost per gate position, exclusive
of parking and equipment (May, 1970 dollars) \$1,960,000

F. Study #6: The Suburban Scheme, October, 1969

Description:

If scheme #5 is unfolded, so to speak, and placed on a single level, the basis of Study #6 is obtained. This scheme is designed specifically for suburban locations, where land prices are lower. It assumes that few passengers will come or go by public transportation, and that sufficient land is available to satisfy parking requirements on open lots. Structural costs are reduced by building on grade wherever possible. Earth, trees, and grass, inexpensive architectonic elements that are prominent in the suburban landscape, are used as the main exterior materials of the

metroport. The problem of aircraft noise, more acute in quiet suburbia than downtown, is dealt with by locating the terminal near an already-noisy highway intersection, by using flight paths over the highways, by buying a larger buffer zone of land around the terminal, and by using mounds of earth as acoustic barriers between the flight deck and surrounding neighborhoods. It should be noted here that although trees are used as visual barriers, they have little value as noise barriers or noise absorbers.

The flight deck surface is the same cellular steel deck as that used in previous schemes. It is supported, however, not on steel trusses, but on short posts and beams, above a pit which houses the necessary mechanical and acoustical systems. Surrounding the deck are sloping, grassy banks of earth which serve to block direct transmission of sound from the landed aircraft to surrounding areas. Fuel tanks are buried in the banks.

Viewed from surrounding neighborhoods, the metroport resembles a park. Parking lots are screened by mounds and bosques. The metroport building and the flight deck are sunk below grade, and the roof of the building is covered with a few inches of soil and is planted with grass. Inside the building, however, the traveler has

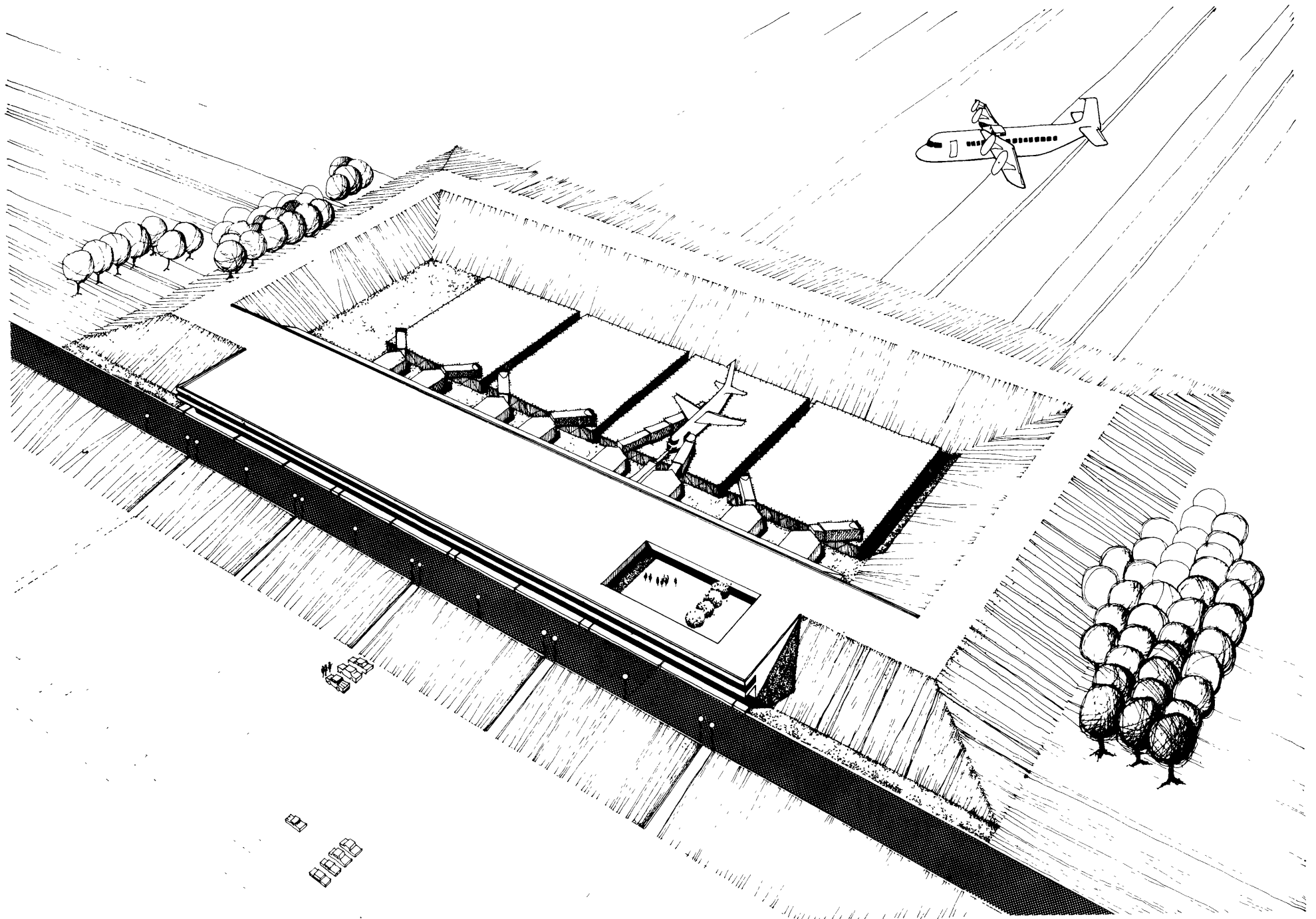
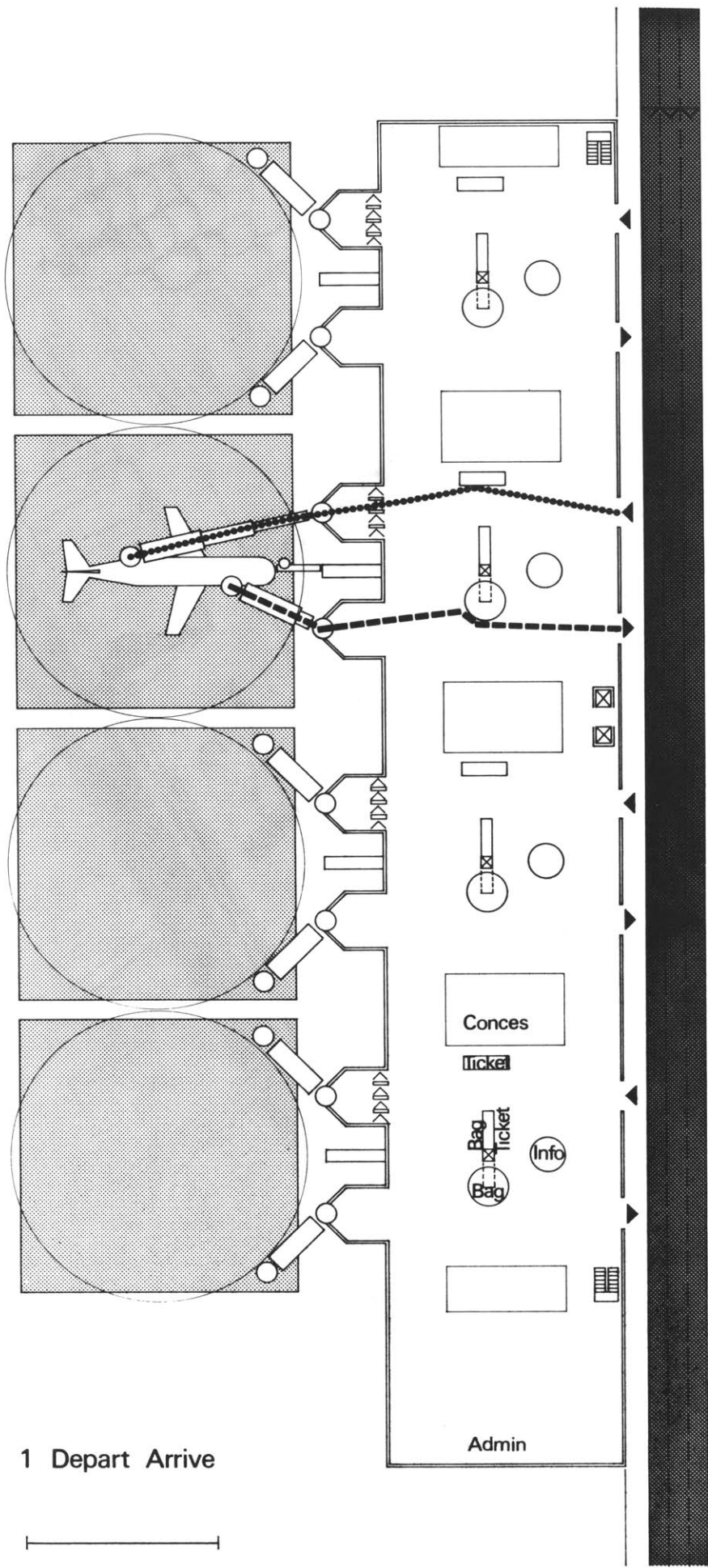

Fig. V-F.1. The Suburban Scheme: Aerial View



1 Depart Arrive



Fig. V-F.2. The Suburban Scheme: Floor Plan

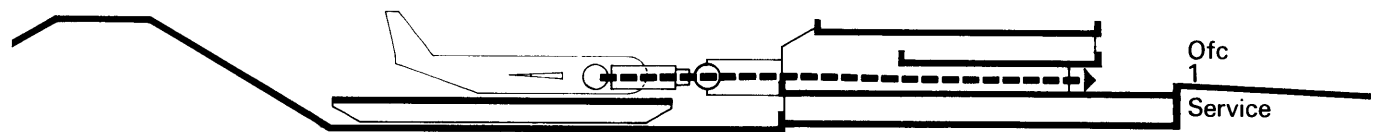
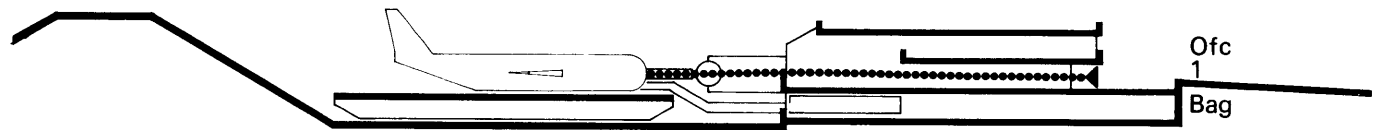

no feeling of being underground. The entire facade is glass, and a large interior courtyard opens to the sky.

Evaluation:

This "unfolded" scheme has two important advantages over its "folded" predecessor: the passenger traverses only a single level, and if the terminal is properly planned, he can see his airplane from the time he enters the door of the building from the curb. It is, in addition, less expensive to construct, especially when the parking accommodations are taken into account. All these advantages, however, are contingent on having plenty of land available for construction. The mixed situation for taxicab operators remains, although it is perhaps of less detriment in the suburban situation.

Land required per gate position:	52,500 sq.ft. plus parking
Flight deck area per gate position:	19,600 sq.ft.
Enclosed public area per gate position:	19,500 sq. ft.
Average distance curb to aircraft: Departing:	250 ft.
	Arriving: 250 ft.
Level change curb to aircraft: Departing:	0
	Arriving: 0
Construction cost per gate position, exclusive of parking and equipment (May, 1970 dollars):	\$1,860,000

G. Study #7: The Central Scheme, November, 1969

Description:

Designs 1 through 6 are all linear schemes. A linear scheme is attractive because of its inherent simplicity and its capability for expansion. Yet the passenger may find it difficult to locate the proper gate, and while seeking his gate he may walk a relatively long distance. A scheme of clustered gate positions, although less simple to construct than a linear arrangement, and incapable of expansion, might be somewhat more efficient and less complex from the point of view of the passenger. Study #7 is such a cluster scheme, designed in order to explore more fully the "Polygonal" configuration discussed in Chapter III.

The enplaning passenger arrives at the terminal anywhere along its perimeter driveway. He purchases his ticket and deposits his baggage at the first available machine he encounters. He then waits for his flight in the single common waiting area in the center of the terminal. Meanwhile, his aircraft arrives on one of the four pads above, and its passengers disembark across a loading bridge to a lounge which accommodates the arriving passengers from two pads. From here an escalator descends to the main concourse, where transferring passengers may step off,

then to the floor below, where luggage may be recovered and ground transportation boarded.

When his flight is called, the passenger must consult lighted signs above the two "up" escalators and choose which one to take. In order to board the escalator he must pass an automatic gate which checks his ticket. In the boarding lounge at the top of the escalator, he may find himself with passengers from another flight, but again he may select the proper doorway by reading the signs, and the automatic gate at each door will reject him if he is in error. He boards his aircraft, as in the other schemes, through a telescoping loading bridge.

Analysis:

Initially the departing passenger has an easy task: he can enter the terminal at any point and simply walk to the center. At the center he has only two remaining chances to err in choosing his path, and both are minimized by electronic ticket-checkers. The building is compact, and enplaning and deplaning passengers are effectively separated for efficient flow. Walking distances, however, are not as short as had been expected.

Passenger problems might arise because of the mixture of people for all flights in one common waiting area. The

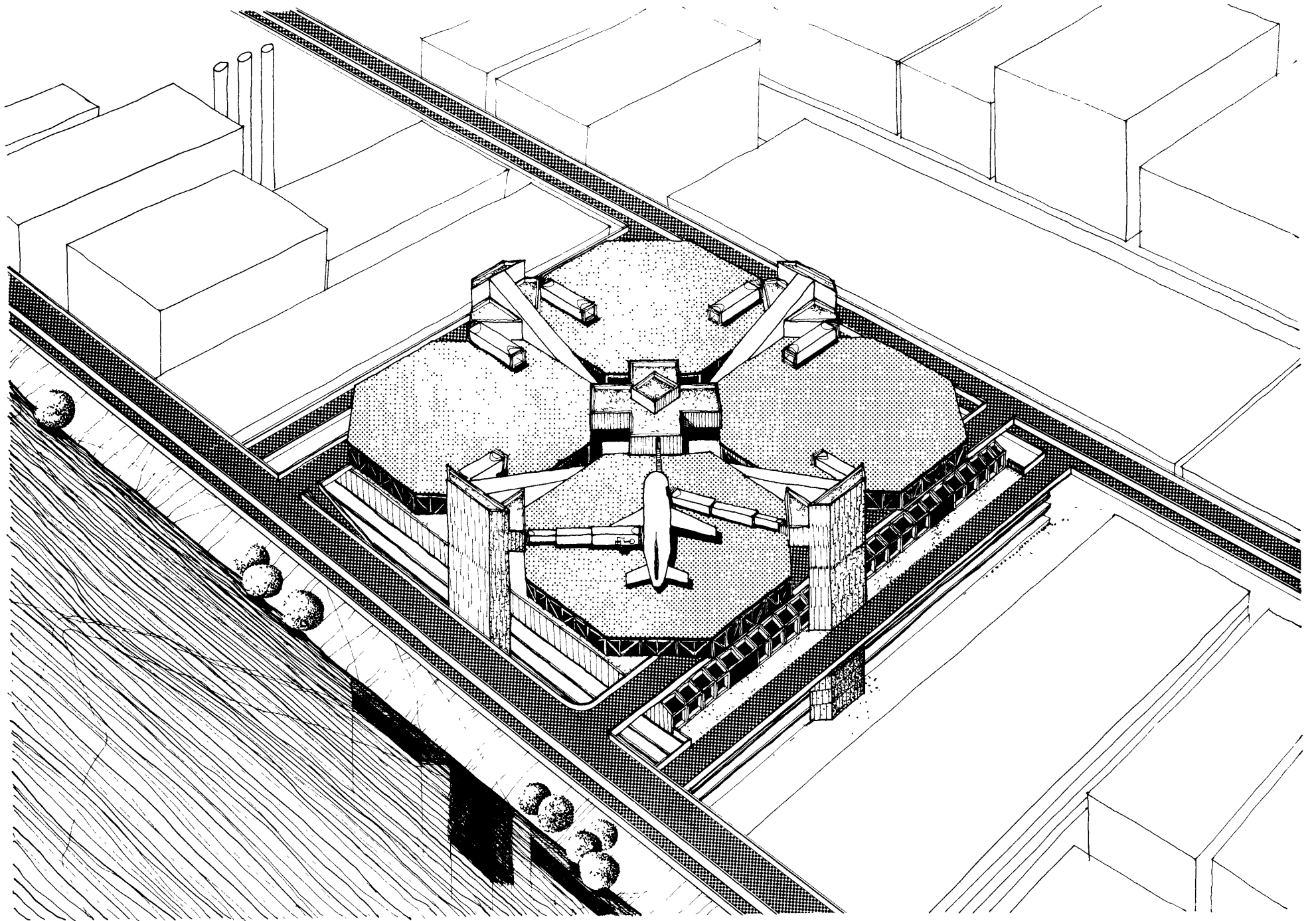

Fig. V-G.1. The Central Scheme: Aerial View

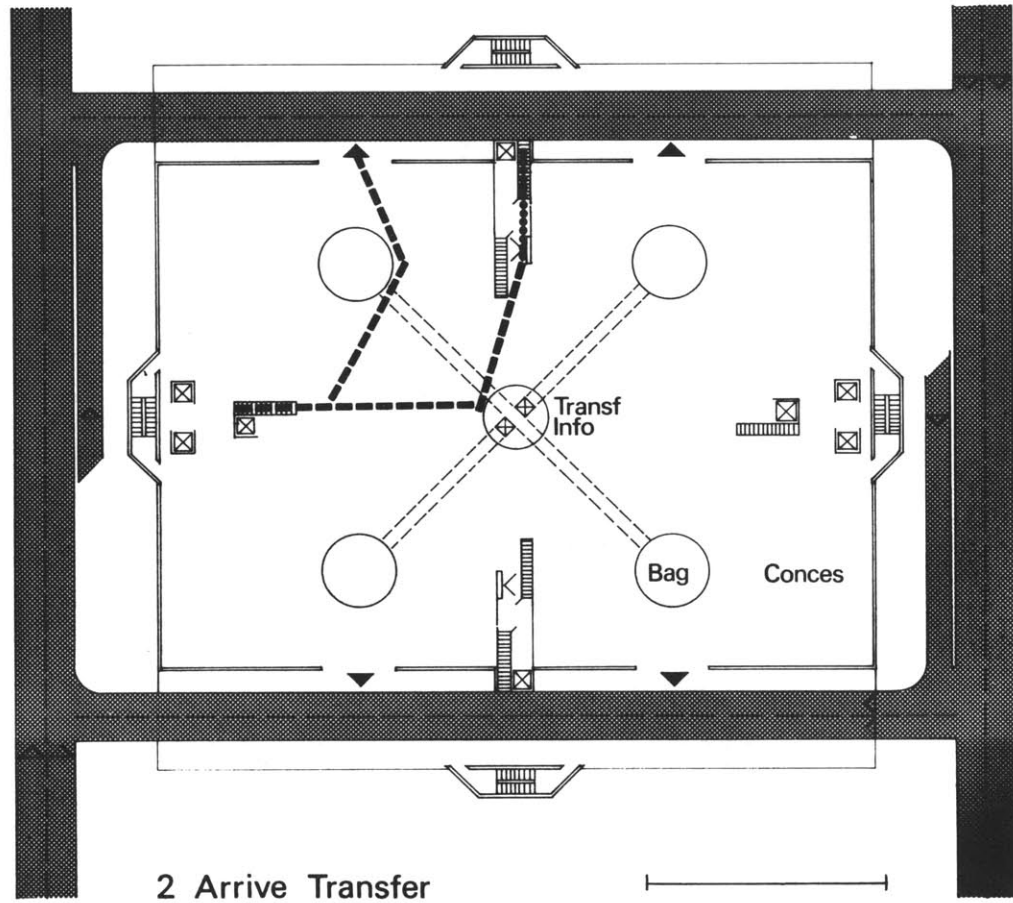
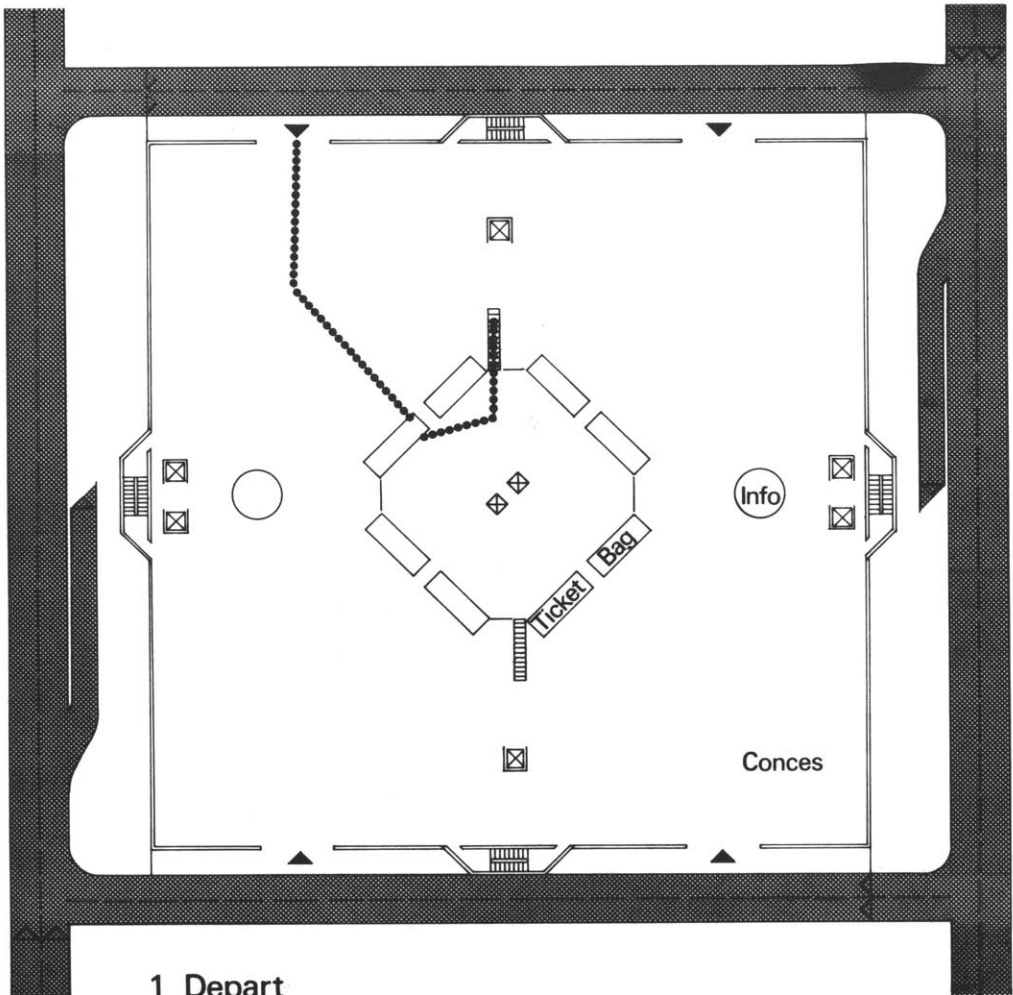
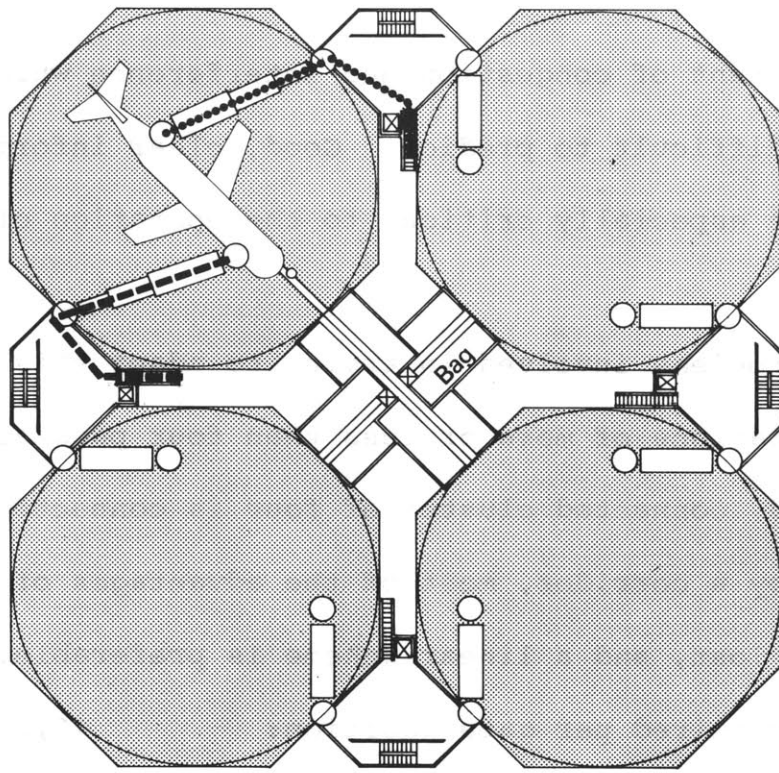

Fig. V-G.2. The Central Scheme: Floor Plans



3 DECK

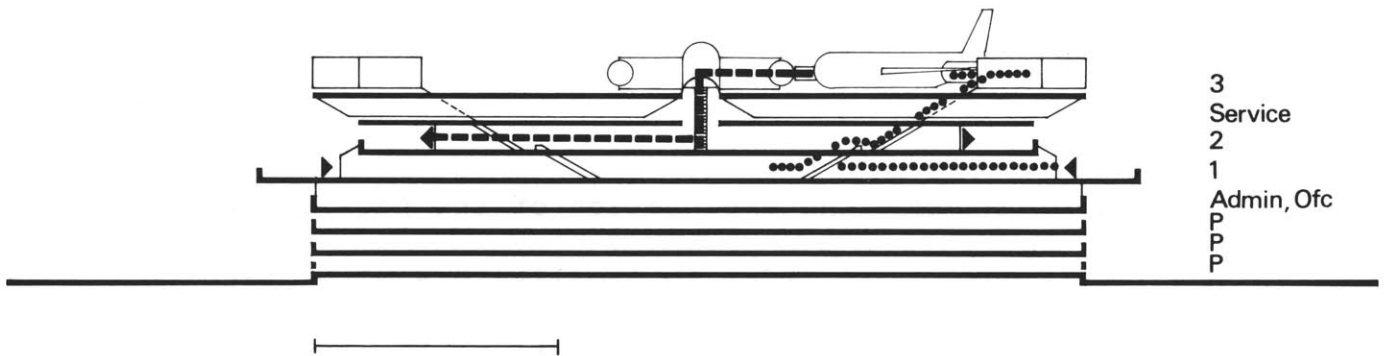

Fig. V-G.3. The Central Scheme: Deck Plan, Section

type and extent of congestion and interference which could occur are difficult to predict. Good, clear information-giving devices are especially critical to the operation of this terminal.

The problems involved in trying to adapt this design to configurations of more or less than four pads are acute. If a second, connected cluster of four is connected to the first by a corridor, most of the advantages of the design are lost, and a linear scheme is preferable.

Land required per gate position: 40,000 sq.ft.

Flight deck area per gate position: 22,000 sq.ft.

Enclosed public area per gate position: 36,250 sq.ft.

Average distance curb to aircraft: Departing: 380 ft.
Arriving: 260 ft.

Level change curb to aircraft: Departing: Ascent 50 ft.
Arriving: Descend 35 ft.

Construction cost per gate position, exclusive of
parking and equipment (May, 1970 dollars): \$2,925,000

H. Study #8: The Split-Level Scheme, December, 1969

Description:

Study #8 resumes the exploration of the possibilities of a linear scheme. In order to facilitate a more direct relationship between ground transportation, the terminal,

and the aircraft, it abandons any attempt to maintain compactness by putting the terminal spaces beneath the flight deck.

The departing passenger's taxi arrives at the curb in front of the gate position (Figure V.H.2., area 1), guided by overhead signs. The passenger can look straight through the thin, glassy terminal building to the aircraft on the flight deck beyond and slightly below. As he enters the door of the terminal, he sees the machines (4) through which he may check his baggage and obtain his ticket. He waits (5) behind the glass which looks over the flight deck. When his flight is ready to board, he passes a control gate into a small boarding lounge (6), then through a downward-sloping telescoping boarding ramp (7) to the plane. The boarding lounge and control gate, shared with the adjacent gate position, are subdivided by a swinging partition which is positioned according to the relative numbers of passengers going to the two aircraft at a given time.

The arriving passenger also walks down a sloping bridge as he deplanes, thus arriving at the lower level of the terminal (9). If he is to transfer to another flight, he may immediately climb or ride (12) to the

upper level to find his next gate of departure. If not, he claims his baggage at the adjacent console (10) and exits to the curb on the arrivals level (2).

Parking and subway facilities are projected to be on levels below this arrivals level, connected to the two levels of the terminal by stairway and elevators. The space immediately below the flight deck is reserved, as in previous schemes, for service functions associated with the deck. Airport and airline offices are contained in "dead" areas of the two floors of the terminal, enabling the end structure to shrink accordingly.

Analysis:

Two possible drawbacks are seen in this design: One is the larger ground coverage it requires. Whether this is critical or not will depend on the specific site chosen for a metroport. The other is the greater hazard of tripping and falling which is present in sloping boarding ramps. Present-day "jetways" are often used on a considerable slope to reach smaller aircraft, without apparent concern on the part of either the airlines or the passengers. For high-volume situations such as VTOL short-haul service, however, it would seem desirable to install handrails and to design a telescoping floor which does not have the

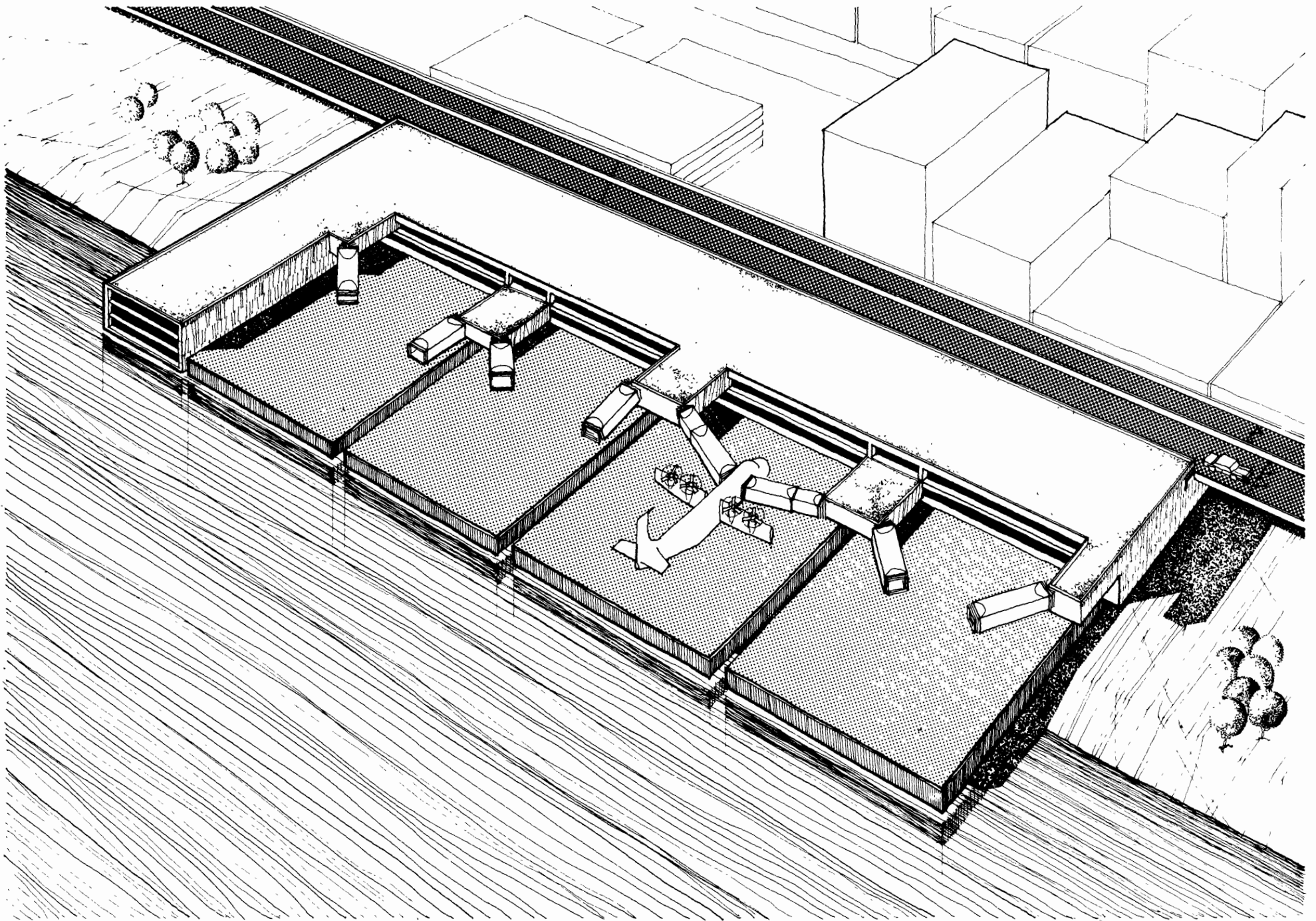

FIG. V-H.1. The Split-Level Scheme: Aerial View

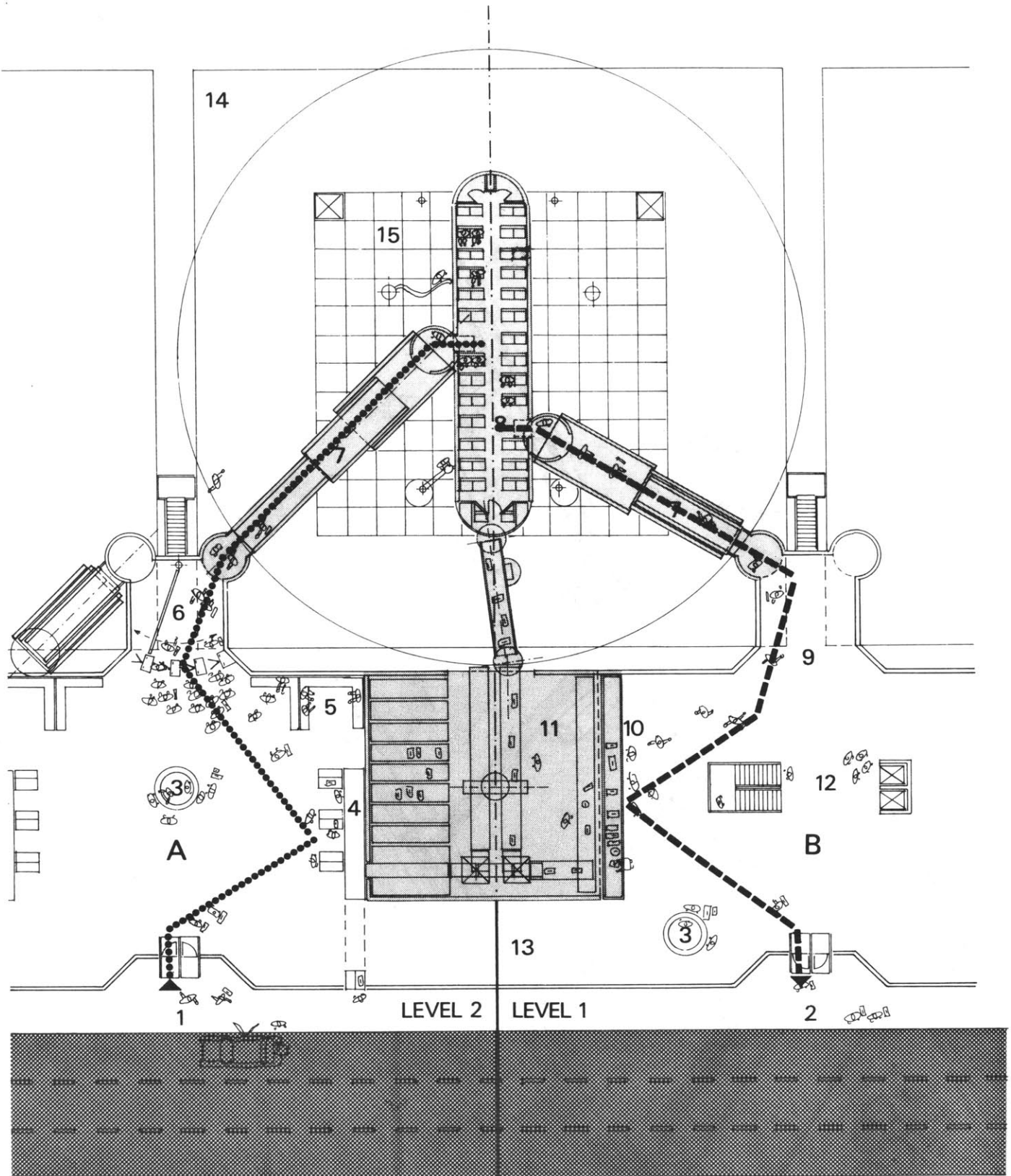
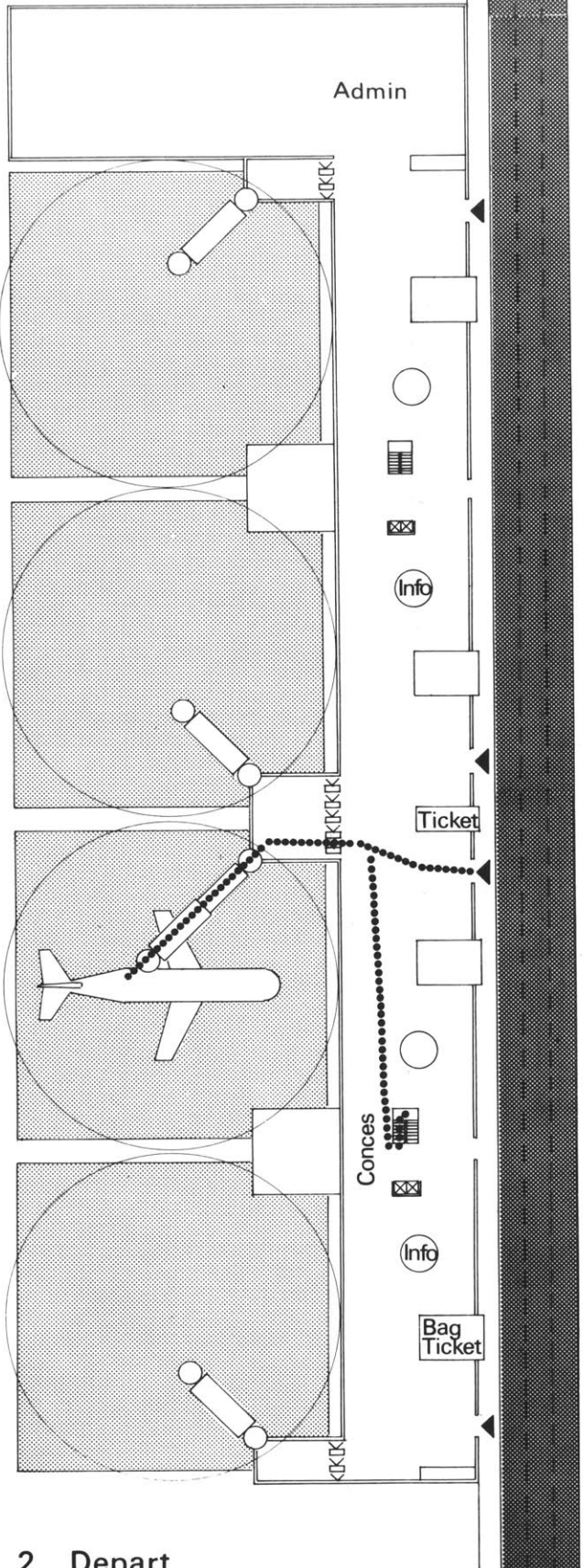
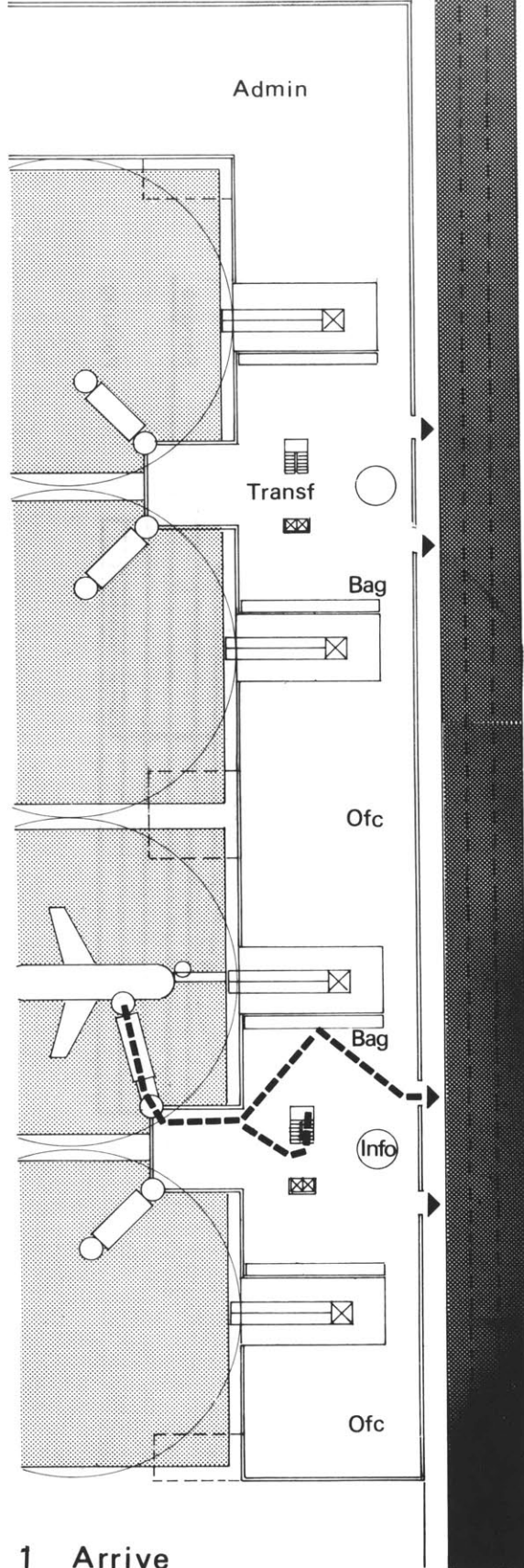

Fig. V-H.2. The Split-Level Scheme: Detail of Gate Position. Note that two separate concourse levels, Level 1 and Level 2, are shown side-by-side on this diagram, divided by a center line.



2 Depart



1 Arrive

Fig. V-H.3. The Split-Level Scheme: Floor Plans

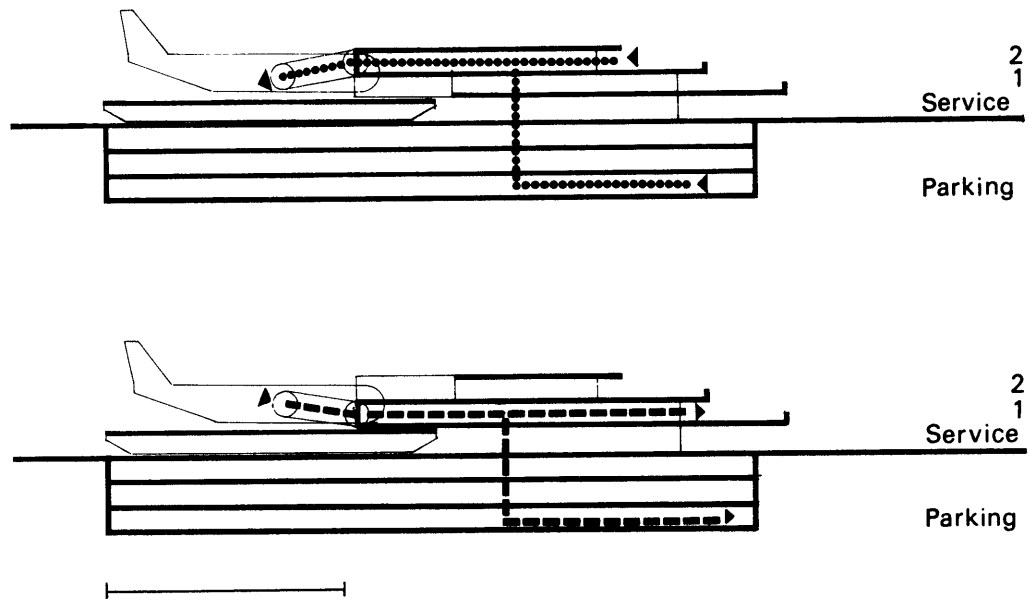

Fig. V-H.4. The Split-Level Scheme: Cross-Sections

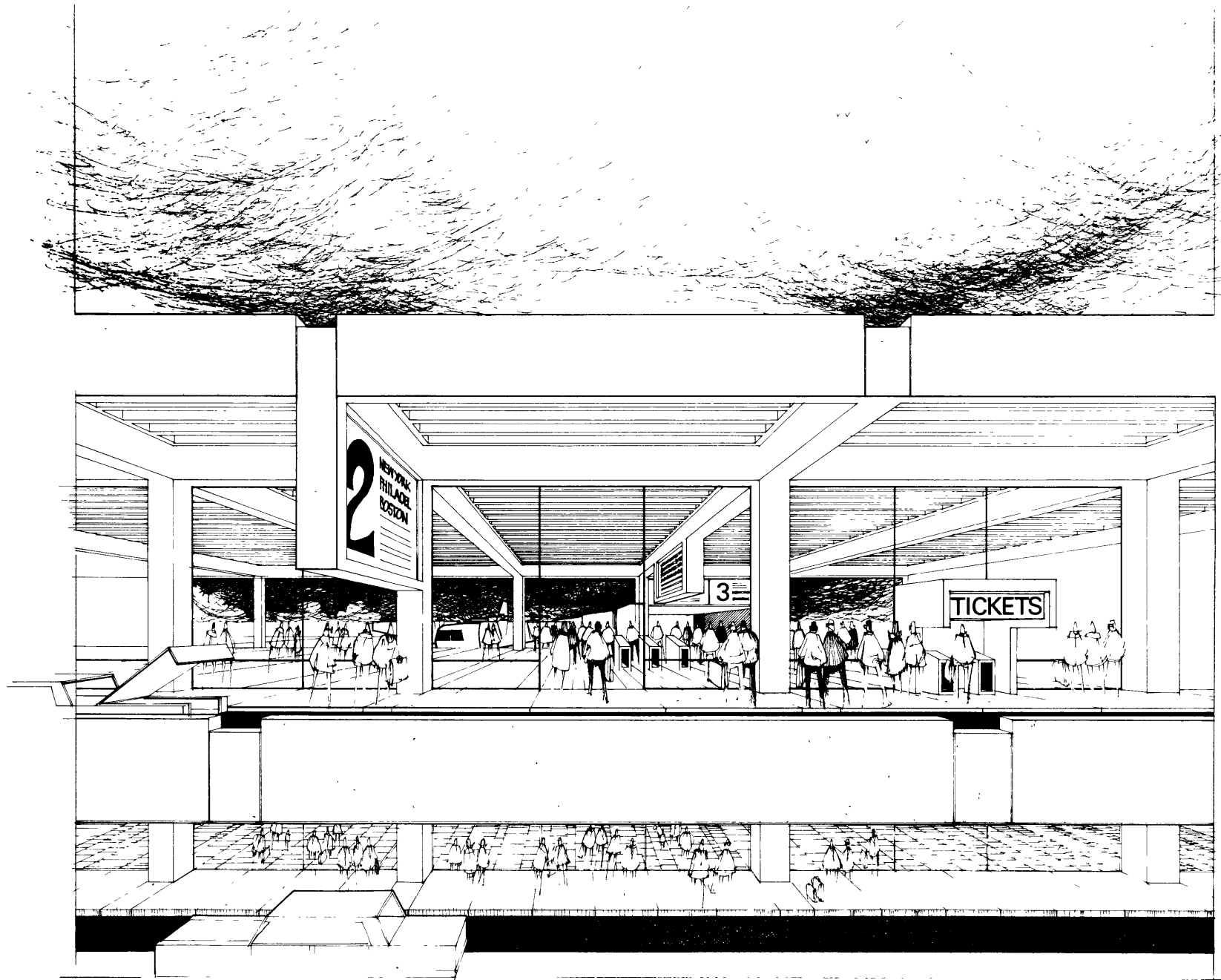

Fig. V-H.5. The Split Level Scheme - Perspective

usual steps in it; a slotted arrangement such as that used in a telescoping painters' stage should suffice, if covered with a stiff floor covering fed from a spring-loaded roll.

The advantages of this scheme are many. It has sufficient curbspace, divided between arrivals and departures. The passenger has his aircraft in view at all times. Walking distances are extremely short, and the paths are direct, with no turns required for most passengers. No ascending of stairs, ramps, or escalators is required except for transferring from one flight to another. Baggage flow to and from the aircraft is direct, efficient, and well related to passenger check and claim operations. The split-level scheme and straight-through circulation result in a terminal that appears to work well in a natural, straight-forward way, without resorting to expensive expedients such as escalators or rising lounges.

This is a modular scheme, designed for easy expansion. It could be doubled over in a back-to-back configuration on a large site, but the central road loop would make pedestrian communication between the halves of the terminal difficult.

Land required per gate position: 38,250 sq.ft.
Flight deck area per gate position: 19,600 sq.ft.
Enclosed public area per gate position: 22,500 sq.ft.
Average distance curb to aircraft: Departing: 190 ft.
Arriving: 190 ft.
Level change curb to aircraft: Departing: Descend 7 ft.
Arriving: Descend 7 ft.
Construction cost per gate position, exclusive of
parking and equipment (May, 1970 dollars): \$1,686,000

I. Study #9: The Suburban Split-Level Scheme, December, 1969

Description:

Study #9 not illustrated, is simply a ground-level adaptation of Study #8, and is similar in outward appearance to Study #6. Automobile parking could be buried under or adjacent to the terminal, but for maximum economy it would be placed in open lots on the surface. The primary advantages of a ground-level metroport in a suburban situation have already been described under Study #6. The split-level scheme proposed here is believed to be preferable to the single-level scheme.

J. Study #10: The Folded-Wing Scheme, December, 1969

Description:

A bus terminal and an air terminal designed to handle

equal numbers of passengers do not occupy the same amount of land. One can readily see in a multi-fingered conventional airport plan that an airport building is large because it serves large vehicles. If airplanes were the size of buses, the fingers could be a fraction of their usual length, and terminal construction and land acquisition costs would decrease, along with passenger walking distances. Thus the question arose whether indeed we could not make airplanes as small as buses at their gate positions. Study #9 is an exploration of this question.

Folding wings are nothing new; carrier-based airplanes have used them for decades. Folding rotors are already under discussion for certain commercial VTOL aircraft. A folding tilt-wing would seem to be difficult, however.

The question of reliability of folded wings and rotors needs to be more fully explored. Commercial aircraft already rely on folding landing gear, and this fact together with existing folding-wing experience would give hope of designing sufficiently reliable folding mechanisms. The question of weight, initial cost, and maintenance cost of the aircraft must also be considered against the potential saving in cost and gain in convenience in air terminal construction and operation.

Fifty-foot-wide aircraft stalls are provided at four gate positions in this scheme. Since the aircraft cannot take off or land from these stalls, a separate common area is provided for landing and takeoff. Aircraft are towed between this area and the stalls by moving cables running in recessed tracks in the flight deck. Telescoping loading bridges reach between the stalls for loading and unloading of passengers. The terminal building operates essentially the same as the split-level scheme, Study #8.

Evaluation

As can be seen from the statistics which follow, this is indeed a compact scheme. But the compactness has its price: curbspace is insufficient for the volume of passengers which could be expected; and the towing of aircraft in and out of the stalls from a single flight pad could be expected to add several minutes to total ground time, and to result in occasional waits for a clear pad, either in the air or in the stall.

Land required per gate position	28,000 sq.ft.
Flight deck area per gate position	14,000 sq.ft.
Enclosed public area per gate position	14,300 sq.ft.

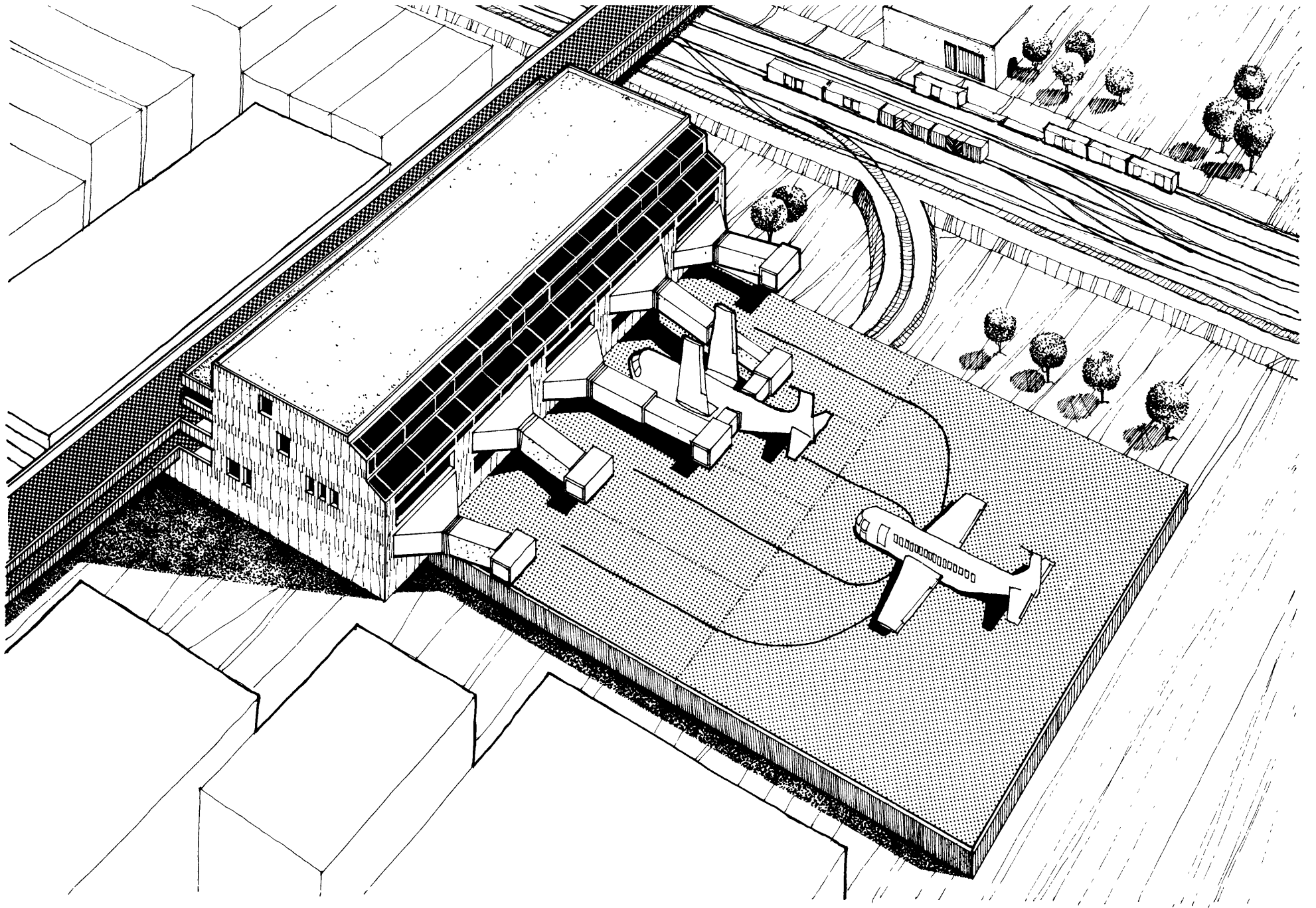
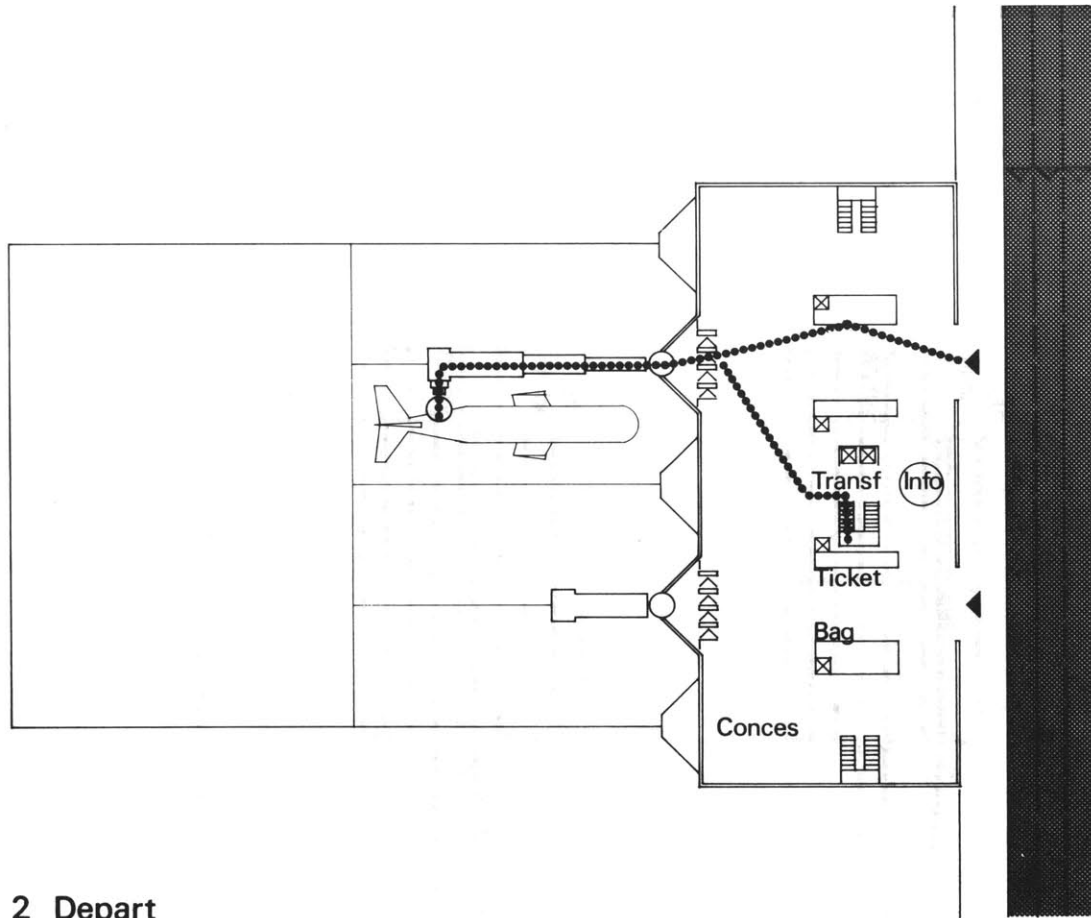
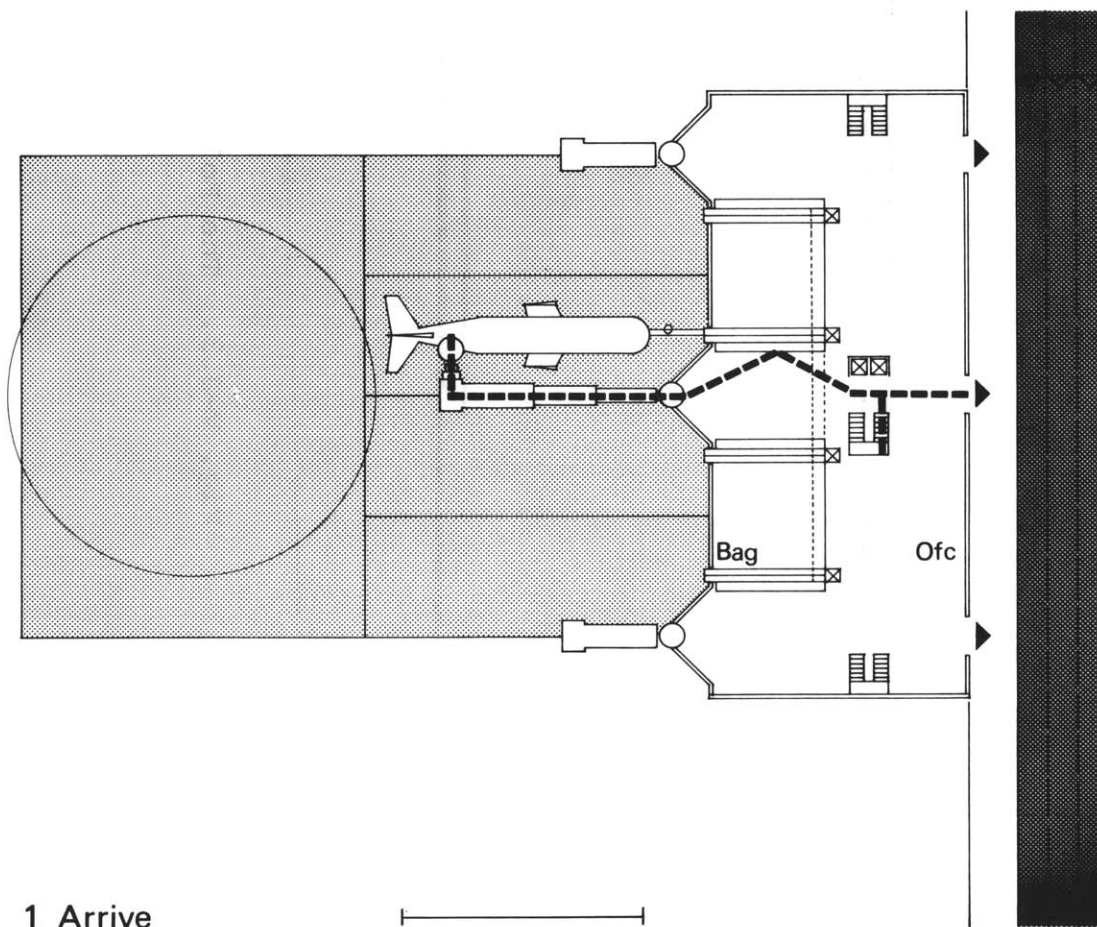

Fig. V-J.1. The Folded-Wing Scheme: Aerial View



2 Depart



1 Arrive

Fig. V-J.2. The Folded-Wing Scheme: Floor Plans

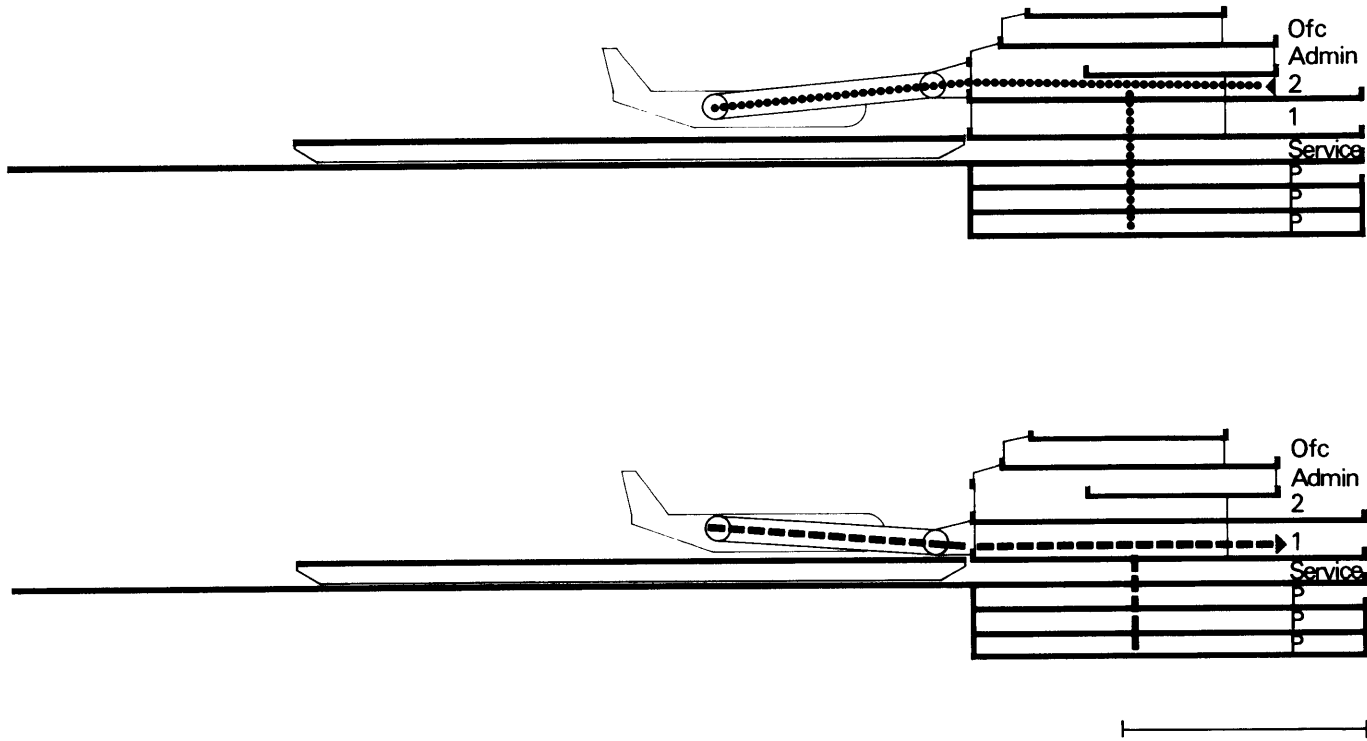

Fig. V-J.3. The Folded-Wing Scheme: Cross-Sections

Average distance curb to aircraft:

departing: 190 sq.ft.
arriving: 190 sq.ft.

Level change curb to aircraft

departing: Descend 7 ft.
arriving: Descend 7 ft.

Construction cost per gate \$810,000.
position exclusive of parking
and equipment (May 1970 dollars)

K. Conclusions

From among the foregoing ten designs, number eight, the Split-level Scheme, together with its suburban counterpart, number nine, appears to come closest to satisfying the need for a simple, efficient, economical metroport. By the straightforward means of placing the floor level of the aircraft midway between the upper and lower floor levels of the terminal, stair-climbing (or escalator riding) has been eliminated for all but the transferring passenger. The terminal is compact and easy to traverse. The entire metroport could be placed on land, over water, or over roads or railroads. With minor modifications, it should fit the majority of metroport sites which are likely to be selected.

It should be noted, however, that if the terminal continues to expand linearly, the transferring passenger will

be subjected to longer and longer walks between flights. In all probability a VTOL metroport should not grow beyond six or eight gate positions. Such a size will handle a very large number of flight operations, many more than a conventional airport building with the same number of gates. When six or eight gate positions cannot handle the traffic in an area, another metroport should be built on another site.

It is not proposed that this is a finished design. It is obviously diagrammatic in character. It will require the addition of considerable detailed design work. It will require considerable modification to fit it to specific sites. In this process, it will probably change a great deal, but it is hoped that its basic virtues will be retained in the finished buildings.

Appendix: Metroport Construction Costs

The cost figures for the various metroport designs were extrapolated from data worked out on Study #8 by a Boston architectural cost consultant. They are reasonably accurate estimates as of May, 1970, but are subject to several variations which must be noted here.

As of May, 1970, inflationary increases of 1% to 1½% per month in construction costs are to be expected in the foreseeable future. In that this is considerably more rapid than the inflation of prices in general, it is especially important that it be recognized in extrapolating the costs to future dates of construction.

The costs represent Boston prices, and may have to be adjusted up or down for other localities.

A flat, clear site requiring driven piling is assumed for all designs. Building over water or on sites requiring extensive preparation can be assumed to be more expensive.

The costs represent completely finished, lighted, air-conditioned buildings of normal-span concrete construction, and steel flight decks as detailed in Chapter IV. They do not include any building equipment or furnishings such

as loading bridges, turnstiles, ticket machines, counters, information boards, baggage handling apparatus, chairs, office furnishings, computers, flight-control systems, aircraft servicing systems, etc. Such costs, currently difficult to predict accurately because of the changing nature of such equipment, must be added, along with land costs, to obtain the total cost of setting up an operating metroport.

The metroport terminal building, as a rule of thumb, can be estimated at \$40 to \$45 per square foot of enclosed floor area. Above-ground parking garages cost about \$11 per square foot, or \$3,500 to \$4,000 per car. Underground garages are approximately \$4 more per square foot, due to increased costs of earthwork, structural reinforcing, waterproofing, mechanical ventilation, and lighting. Elevated roadways can be estimated at \$15 per square foot.

The steel flight deck structure is estimated to cost about \$510,000 per gate position, including columns, trusses, decking, snow melting system, lighting, and fire protection. This does not include foundation costs or addition expenses due to over-water construction. If the design were made standard for a number of metroports, some cost saving would result through economies of larger-scale production of its components.

BIBLIOGRAPHY AND REFERENCES

1. Allen, Edward, BOSTON VERTIPORT, Cambridge, MIT, January 1969 (unpublished).
2. Allen, Edward, THE NEW AIR JOURNEY, Cambridge, MIT, July 1968 (unpublished).
3. BELL AEROSYSTEMS, "Downtown to Downtown at 450 MPH", RENDEZVOUS, Vol. V, Number 4, 1966, p. 5.

BELL AEROSYSTEMS, "Proposed Airbus Network", RENDEZVOUS Vol. V, Number 4, 1966, p. 8.
4. The Boeing Company, AIR TRAFFIC FORECASTS, February 1968.
5. The Boeing Company, BOEING 747 at the AIRPORT. Renton, Washington, May 1967.
6. The Boeing Company, STUDY OF AIRCRAFT IN SHORT HAUL TRANSPORTATION SYSTEMS.
7. The Boeing Company. THE AIRPORT BAGGAGE-HANDLING SYSTEM/ AN EVALUATION METHOD, Renton, Washington, Author, Richard Tagawa, January 1968.
8. Bright, Cooper, B., "Floating Airport: Key to Inter-City Traffic", Astronautics and Aeronautics, September 1967, pp.46-51.
9. Cheyno, Elbert, VERTIPORT DESIGN AND OPERATIONS. Burbank: Lockheed-California Company, 1967.
10. Draper, Charles Stark, PORTS FOR MODERN FLIGHT VEHICLES. Cambridge: M.I.T., May 1959.
11. Edwards, Gordon, Planning the Metropolitan Airport System. Washington: Federal Aviation Agency, January 1965.
12. Edwards, Jack W., A Look at the Factors which Affect Gate Requirements at Airports. Institute of Transportation and Traffic Engineers, August 1967.
13. Ekistics. The Transport Fit: Needs and Facilities. Athens: The Athens Center of Ekistics of the Athens Technological Institute, January 1968.

BIBLIOGRAPHY and REFERENCES (continued)

14. Endicott, Fred J., "Airport Transportation," Tech Engineering News, March 1969, pp. 31-34.
15. Engineering Foundation Research Conference. ACCESS TO AIRPORTS: BASIC POLICY DEVELOPMENT ISSUES. Milwaukee University School, 1968.
16. Gallant, R., Application of the Calculus of Variations in Determining Optimum Flight Profiles for Commercial Short Haul Aircraft. Cambridge: MIT, November 1966.
17. Gallant, R., Scully, M., Lange, W., Analysis of V/STOL Aircraft Configurations for Short Haul Air Transportation Systems, Cambridge: MIT, November 1966.
18. Howard, Lee R., Overall Analysis of Commercial V/STOL Systems. Burbank: Lockheed-California Company, October 1967.
19. Howard, Lee R., Kahn, Joel F. Commercial V/STOL Systems Analysis by Airline Simulation. Burbank: Lockheed-California Company, August 1967.
20. Kahn, Joel F. V/STOL Airline System Simulation, Burbank: Lockheed-California Company, October 1967.
21. Lange, W.R., The Design and Operation of VTOL Metroports, Engineering Thesis, June 1970.
22. Lockheed-California Company. Lockheed CL-1026 Speedstar - Compound Solution to Intercity Transportation. Burbank: Lockheed-California Company, December 1967.
23. Lockheed-California Company. The L-1011 Summary. Burbank: Lockheed-California Company, April 1968.
24. Lockheed-California Company. L-1011 Airplane Characteristics - Airport Planning, Burbank: Lockheed-California Company, July 1968
25. Lockheed-California Company. Preliminary Market Analysis of the CL-1026 Compound Aircraft. Burbank: Lockheed-California Company 1967.

BIBLIOGRAPHY AND REFERENCES (Continued)

26. Lockheed-California Company, Commercial Market Research - Vertiport Design and Operation. Burbank: Lockheed-California Company.
27. Lockheed-California Company. The Lockheed Rigid Rotor - Commercial Applications and Impact. Burbank: Lockheed-California Company, February 1968.
28. Lockheed-California Company. Lockheed 1026 Turbo-Compound Interurban Transport.
29. Manheim, Marvin L. Search and Choice in Transport Systems Planning or Technology in Society. Cambridge, MIT.
30. Miller, Rene H. and Simpson, Robert W., V/STOL in the Northeast Corridor. Cambridge: MIT, September 1968.
31. MIT and US Department of Commerce. Short Haul Air Transportation. A Systems Analysis.
32. O'Doherty, John D., A Location Study for a System of V/STOL Airports in The Boston Metropolitan Area. Cambridge, MIT, January 1966.
33. Paullin, R. L. Passenger Flow at Departure Lounges. Institute of Transportation and Traffic Engineers, July 1966.
34. The Port of New York Authority. Airport Requirements and Sites to Serve the New Jersey-New York Metropolitan Region. New York: Port of New York Authority, 1966.
35. Sarames, George N. Urban Public Resources and VTOL Terminals. Burbank: Lockheed-California Company, October 1967.
36. Schriever, Bernard H. and Seifert, William W., Air Transportation 1975 and Beyond. A Systems Approach. Cambridge, MIT Press, 1968.
37. Sikorsky Aircraft. Commercial VTOL Market Potential, Stratford, Sikorsky Aircraft, February 1968.
38. Sikorsky Aircraft. Final Information Response of Sikorsky Aircraft - Northeast Corridor VTOL Investigation, Vol. II. Stratford: Sikorsky Aircraft, 1969.

BIBLIOGRAPHY AND REFERENCES (Continued)

39. Sikorsky Aircraft. VTOL Transportation System.
40. Simpson, R.W., WEATHER CONDITIONS AFFECTING VTOL AIRBUS OPERATIONS IN THE NORTHEAST CORRIDOR. Cambridge: MIT, November 1966.
41. Simpson, R.W., Computerized Schedule Construction for an Airline Transportation System. Cambridge: MIT, November 1966.
42. Space/Aeronautics. V/STOLS. A Special Report. New York: Conover-Mast Publications, Inc., May 1965.
43. Statler, William H., and Blay, Roy A., Role of the Rotary Wing in Future Short Haul Transportation.
44. Sessel, Robert F., and Gallagher, John E., A Standard Method for Estimating VTOL Operating Expense (A More Realistic Approach). Burbank: Lockheed-California Company, October 1967.
45. Tillman, Charles E., Allocation of Manhattan Air Traffic-Vertiport Versus STOLport. Burbank: Lockheed-California Company, April 1968.
46. Sikorsky Aircraft. Interim Report on Heliport Requirements Analysis. Stratford: United Aircraft Research Laboratory, July 1968.
47. Wetmore, Joseph W., "STOL TRANSPORTS AND THEIR TERMINAL REQUIREMENTS", Journal of the Proceedings of the American Society of Civil Engineers, January 1966, pp. 77-93.
48. Winick, Alexander B., VSTOL All Weather Guidance System. Washington: Federal Aviation Administration, 1967.