

VII. TUBE RESEARCH AND DEVELOPMENT

A. MAGNETRON DEVELOPMENT

Dr. S. T. Martin

A. G. Barrett

1. High-Power 10.7-Cm Magnetron

a. Testing and design

MF-8B magnetron is now undergoing bake-out on the tube-processing vacuum system. The next magnetron of the series, MF-9B, is ready to be assembled, pending the completion of more window sealing experiments.

A great deal of trouble has been encountered in completing the seal-on of the window to the tube. Several trials were made to join the window cup assembly to the MF-8B magnetron. The first three trials employed the hydrogen furnace brazing method used in assembling MF-7B magnetron. This method proved to be too critical for reliable results. The gold-wire method (1), originally used in early British magnetron construction, was then adapted to the present design.

The successful joint consists of a 0.030-inch diameter, 24-carat gold wire ring squeezed between carefully lapped copper surfaces. The copper expansion section of the window cup had to be shortened and thickened to withstand the compression applied by stainless steel clamping rings and studs. The studs were tightened with a torque wrench in small steps to maintain even pressure on the gold wire.

Further experiments are in process to increase the reliability of this window assembly method, and to improve the sequence of operations in the construction of these magnetrons.

b. Thoria cathodes

Shortly after power was applied to the thoria cathode in the test diode, and before seal-off, current and pressure fluctuations indicated a hot spot, and burn-out finally occurred. Examination of the diode after it was opened revealed that an end mount had burned away from the cathode. This burn-out is believed to be due to faulty platinum brazing. Since such weak spots cannot be detected by visual observation, future cathodes will be pretested in a glass jar in a helium atmosphere to make sure that heating is uniform.

Further thoria cathode activity awaits completion of the present group of oxide cathode magnetrons.

c. Auxiliary equipment

The tube processing vacuum system, incorporating a stainless steel pumping lead stem and larger diameter glass tubing, has been completed and is now in operation with MF-8B magnetron. Figure VII-1 shows the magnetron connected to the pumping lead

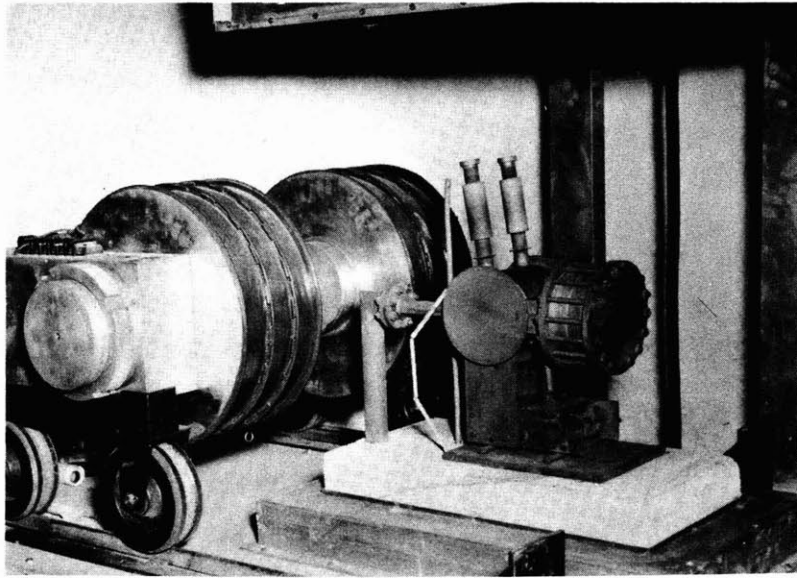

Fig. VII-1 MF-8B magnetron mounted on processing bench.

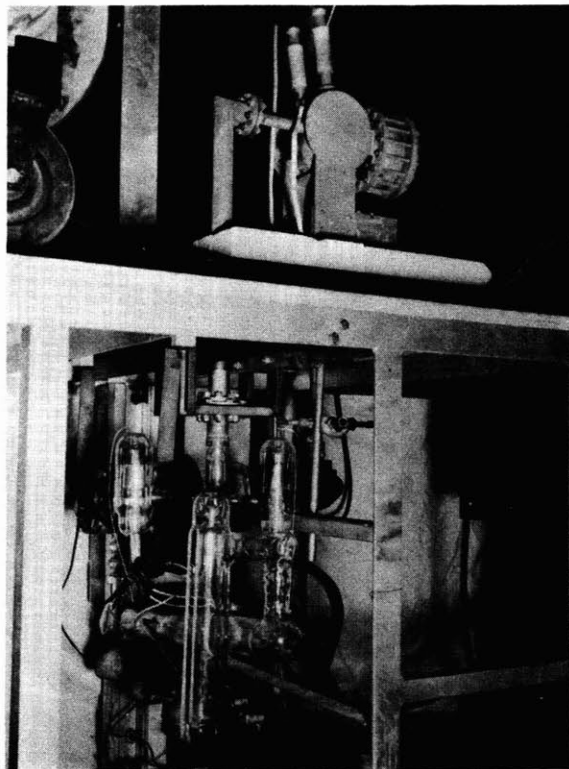

Fig. VII-2 Magnetron vacuum system.

(VII. TUBE RESEARCH AND DEVELOPMENT)

by means of an OFHC copper gasket compression joint. The studs and plates on the magnetron compress the gold-wire window joint described in a previous section.

During bake-out the electromagnet is rolled back, and the oven, which can be seen at the top of the picture, is lowered over the magnetron. The oven base is constructed so that the oven is comparatively gas tight. Dry nitrogen is introduced through the feed pipe which comes up near the cathode leads.

After bake-out and cathode processing are completed, the electromagnet is rolled into position to provide magnetic field, and a pressurized test tank (not shown) containing a water load is connected to the magnetron output section. The magnetron is then subjected to pulsed operation while still on the vacuum system.

The magnetron is sealed off from the vacuum system by pinching off the 3/4 inch copper tubing between the copper gasket joint and the magnetron. One of the features of the system is the method of allowing for motion during pinch-off by means of the rollers under the stand supporting the magnetron. The rollers also permit motion due to thermal expansion to take place in the horizontal direction.

An over-all view of the magnetron and vacuum system is shown in Fig. VII-2. A second copper gasket compression joint connects the pumping lead stem to the permanent glass part of the system. This joint is located under the bench and away from the direct heat of the oven. After pinch-off the whole pumping lead stem can be disconnected and replaced in case the upper copper gasket joint becomes welded together during high temperature bake-out. This arrangement overcomes the difficulties encountered with the old vacuum system as described in the Quarterly Progress Report, January 15, 1951.

The remainder of the vacuum system is of conventional glass construction.

The vacuum system used with the 50-kw r-f induction heater for brazing windows and cathode leads has been rebuilt to secure higher pumping speed. The new system employs a 4-inch metal diffusion pump and attains a minimum pressure of 2.5×10^{-5} mm of Hg. The increased pumping speed is expected to produce better metal-ceramic seals in accord with techniques recently reported by Machlett Laboratories (2) and the Air Materiel Command (3).

Parts are on hand for the connectors for the 25-ohm experimental high power pulse cable. A test assembly has been made on a short spare length of cable, and the connectors are now being assembled to the 60-foot cable.

References

1. W. E. Willishaw, et al: J.I.E.E. 93, IIIA, 984, 1946
2. H. D. Doolittle, et al: Nineteenth Monthly Progress Report, Machlett Laboratories, Springdale, Conn., Dec. 10, 1949; Ibid. Twenty-first Monthly Progress Report, Feb. 10, 1950; Ibid. Final Report, May 10, 1950
3. W. Knecht: AF Technical Report No. 6108, Air Materiel Command, Wright-Patterson AFB, Dayton, Ohio, Sept. 1950

(VII. TUBE RESEARCH AND DEVELOPMENT)

2. Magnetron Research

a. Noise properties of the pre-oscillating magnetron

Further activity in this field has been discontinued for the present.

B. MICROWAVE TUBES

L. D. Smullin	G. Guilbaud	C. E. Muehe, Jr.
Prof. L. J. Chu	H. Haus	L. Roberts
Prof. J. E. Thomas	H. J. Krusemeyer	H. E. Rowe
A. W. Boekelheide		L. Stark

1. Noise and Space Charge Waves

a. Analysis of power in electron beam

An analysis of the kinetic energy in an electron beam was made. Technical Report No. 190 on this subject is in preparation. The results may have possible application to the design of low noise beam-type tubes.

L. J. Chu

b. Experimental noise study

The analysis of the kinetic energy in an electron beam presents us with certain possibilities as to the character of the noise standing wave in the drift tube: the a-c kinetic power may be positive, negative or zero. Which of these exists in a space charge limited stream may be found by a theoretical analysis of the region near the potential minimum. Since it has not yet been possible to carry out this analysis, an experimental approach will be attempted.

The demountable tube shown in Fig. VII-3 has been completed and is now being assembled on the pump. It has a magnetically shielded chamber in which the electron gun is mounted. The electron beam will be Brillouin-focused by an axial magnetic field ($B_{\max} = 750$ gauss). Two resonant cavities are arranged to move within the vacuum, with their coupling lines coming out through rubber vacuum seals. A vane with various hole sizes and a fine grid over one hole is provided on the face of the first cavity. This will allow the beam size to be measured and noise measurements will be made relative to the partition noise caused by the fine grid in the path of the beam.

The first measurements will be of the current standing wave along the beam, in an attempt to get a more accurate value of the SWR than Cutler and Quate were able to get in their first experiment. If the SWR is finite the determination of the sign of the a-c power can be made by using the first cavity as a resistance in series with the beam, and the second cavity as a probe.

H. E. Rowe

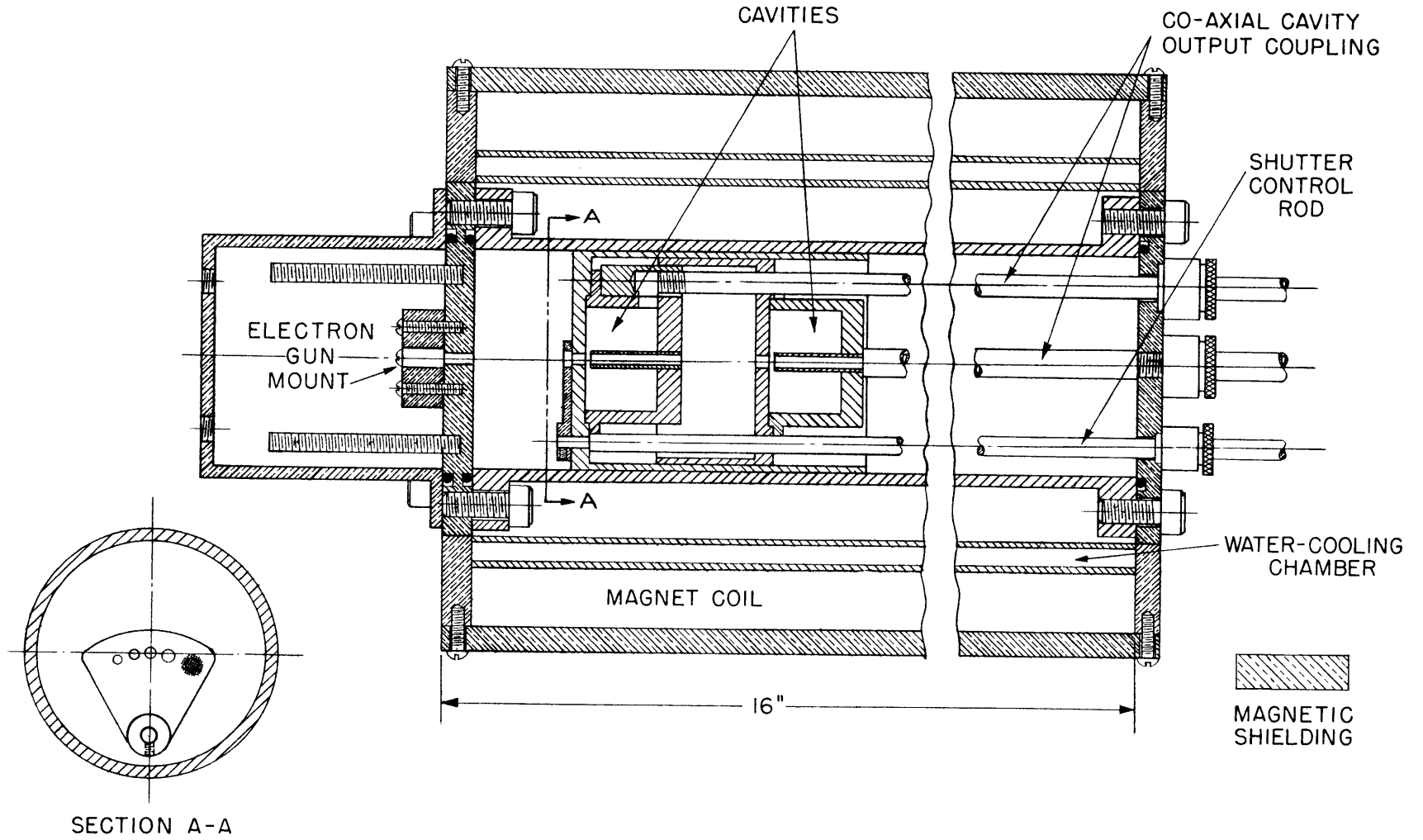

Fig. VII-3 Apparatus for measuring noise space charge waves.

(VII. TUBE RESEARCH AND DEVELOPMENT)

c. Noise reduction by a two-stage electron gun

A theoretical study has been made of the noise-reducing properties of a two-stage gun. This is analogous to Field's "velocity jump", except that the finite gap is accounted for. (It is probably similar to Peter's work at RCA.)

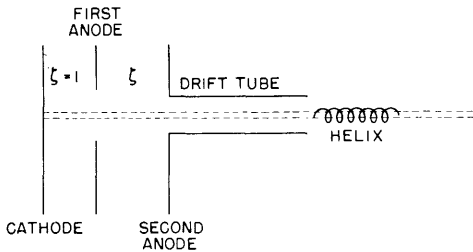

Fig. VII-4

Schematic of traveling wave tube with two-stage gun.

The system analyzed is shown in Fig. VII-4. The Llewellyn-Peterson (1) equations for infinite parallel-plane flow were used for the two stages of the gun (cathode to first anode, and first anode to second anode); Ramo's (2) equations for a single velocity electron beam were used between the second anode and helix; and equations from Pierce's (3) book were used in the helix region.

The expression for the noise figure of such a tube is

$$F = 1 + 0.429 \frac{T_c}{T} \frac{B^2 + H^2 A^2}{2C} M$$

where F is the noise figure, T_c is the cathode temperature, T is the standard reference temperature (290°K), C is the gain parameter of the tube, H is the ratio of the plasma wavelength in an infinite parallel-plane flow to the wavelength in the drift tube,

$$B = \left[\frac{\zeta^{1/2} (1 - \zeta)(1 + a)^{3/2}}{a} + \frac{1 - \zeta(1 + a)}{a} \right]$$

$$A = \sqrt{2a} \left[1 - \frac{\zeta(1 + a)}{a} - \frac{\sqrt{\zeta(1 + a)}}{a} \right]$$

ζ is the space charge factor between the first and second anode, $a = u_c/u_b$, and M is a function of QC , d , and b of the helix; δ of the drift region; and the position of the helix in relation to the anode. If $B^2 + H^2 A^2$ is plotted versus ζ for various values of H and a , minima will occur around a value of $\zeta = 0.6$.

For a conventional single-stage gun the factor $[B^2 + H^2 A^2]$ is replaced by the factor $[1 + 2H^2]$. Since H is a function of $\gamma_0 b$, we may plot a curve of the minimum value of the ratio of these two quantities versus $\gamma_0 b$. Where

$$\gamma_0 = \frac{\omega}{u_c}, \quad b = \text{radius of beam}$$

This graph is shown in Fig. VII-5. The lower the ordinate of this graph, the better the noise figure.

Electrolytic-tank studies are being made of the design of a two-stage gun suitable for use in a 3-cm traveling wave tube.

(VII. TUBE RESEARCH AND DEVELOPMENT)

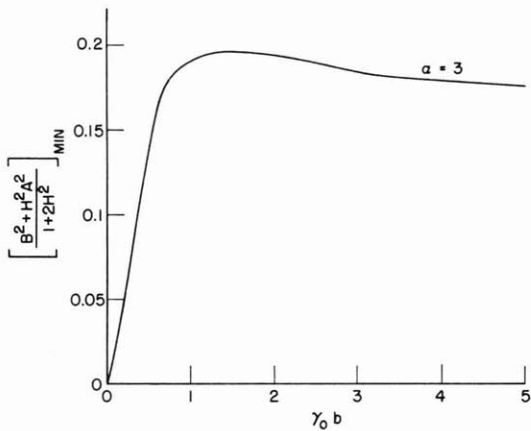

Fig. VII-5 Ratio of minimum noise power of two-stage gun to minimum noise power of one-stage gun.

References

1. F. B. Llewellyn, L. C. Peterson: Proc. I.R.E. 32, 144-166, 1944
2. S. Ramo: Proc. I.R.E. 27, 757-763, 1939
3. J. R. Pierce: Traveling Wave Tubes, Van Nostrand, New York, 1950

C. E. Muehe, Jr.

2. 3-Cm Pulsed Traveling Wave Source

a. Power output tube

The gun of this tube was described in the Quarterly Progress Report, January 15, 1951. The helix is wound of 0.010-inch molybdenum, on a 0.125-inch diameter mandrel, 13 turns per inch, for a total of 74 turns. It is supported by four ceramic rods

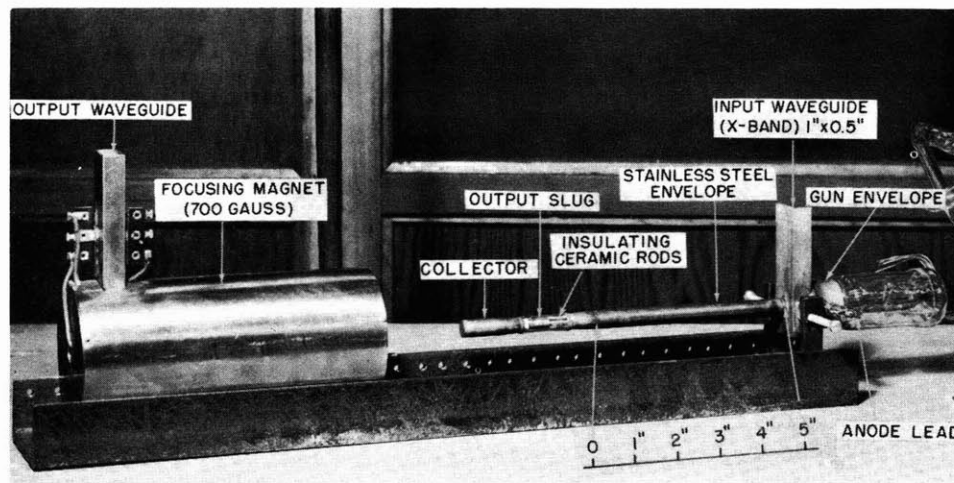

Fig. VII-6 X-band pulse traveling wave amplifier, XP1.

(VII. TUBE RESEARCH AND DEVELOPMENT)

0.060-inch in diameter within a stainless steel envelope. The input waveguide is part of the vacuum assembly and is made of steel. A Kovar-glass window (furnished by Sylvania Electric Products Co.) is BT-brazed to the waveguide. The output waveguide is built into the electromagnet structure and couples to the helix through the short section of glass between the collector and stainless steel tube. A short section of copper is used between the glass and stainless steel.

The first tube assembled is shown on the pump in Fig. VII-6. Unfortunately it developed a leak. A second tube is being assembled.

G. Guilbaud

b. Driver tube

A medium-power tube is being built to act as a driver for the pulse tube described above. A drive power of about one watt is required. A 2 kv, 10-ma tube has been designed and is being built. The mechanical structure will be very much like the pulsed tube in that the input waveguide will be a part of the vacuum envelope.

L. Stark

3. High-Power Traveling Wave Tubes

Some thought is being given to the design of traveling wave tubes for high pulse powers, approximately 1 Mw. Beam-type tubes would require voltages of about 100 kv ($v \approx c/2$). At these phase velocities an ordinary wire or tape helix may not propagate as a helical sheath, but due to the periodicity of the pitch, it may have resonances that cause it to radiate. (This has been shown by S. Sensiper of this Laboratory in an unpublished analysis of the tape helix. His work will appear shortly as a Doctoral thesis.)

Preliminary designs of a 1-Mw tube show that it is not possible to make a single winding helix with a diameter that will give reasonable gain and bandwidth. It appears, however, that multifilar helices may approach closer to the ideal of a helical sheath, and the critical frequencies for a given diameter and velocity are pushed up in approximate proportion to the number of windings on the helix. In order to get a quantitative check of this theory, measurements will be made on single and bifilar helices wound to give a phase velocity of about $c/2$. Apparatus is being constructed for these measurements.

L. Stark

4. Operation of Pulsed Magnetrons into a High Q-Load

The circuit described in the Quarterly Progress Report, January 15, 1951 has been shown to be capable of coupling most of the magnetron power into an external high Q cavity (Fig. VII-7). However, it was found that very intense X-radiation was generated in the cavity. With an indicated pressure of 2×10^{-6} mm Hg on the ionization gauge on

(VII. TUBE RESEARCH AND DEVELOPMENT)

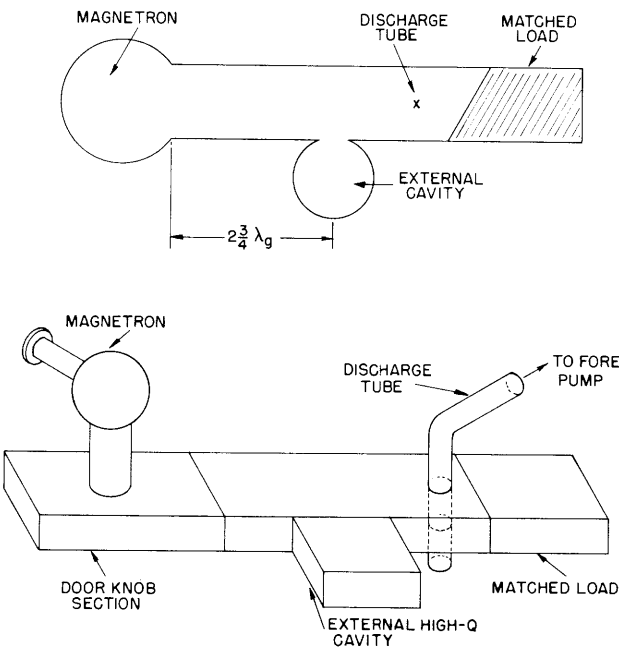

Fig. VII-7 Switching circuit for coupling the energy of a magnetron into an external cavity.

the pumping lead, there was a visible bluish discharge in the cavity and a total radiation intensity of 3r per minute was measured at point X in Fig. VII-8. Sixty percent of this radiation had a photon energy ≤ 100 kev and the limit of the spectrum was about 1 Mev, with a peak magnetron power output of about 0.5 Mw. (The radiation measurements were made by Dr. S. Levin of the Health Physics Department.)

To minimize the amount of lead required to shield the apparatus, and to eliminate breakdown across the iris of the cavity on the waveguide side of the vacuum window, a new cavity and waveguide section have been built, both of OFHC copper waveguide. The waveguide section is sealed by resonant vacuum windows on both ends. The cavity as well as the waveguide section are evacuated through a pumping hole in the broad side of the waveguide. The cavity is tuned by changing the distance between the top and bottom faces by squeezing.

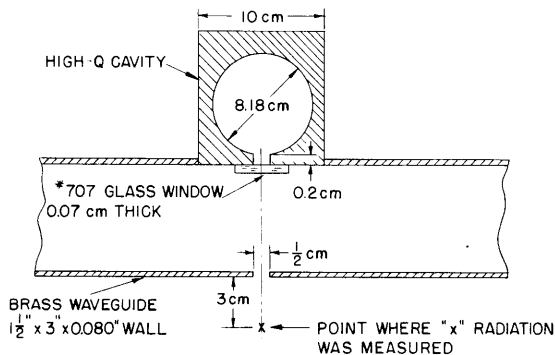

Fig. VII-8 Position where the x-radiation intensity was measured.

An attempt will be made to determine the minimum voltage required of an injected signal on the tips of the magnetron vanes to lock the magnetron into the desired mode of operation. A c-w magnetron will be used to inject a locking signal through a 1B38 pre-Tr tube. The pre-Tr tube will break down under the higher power of the pulsed magnetron and connect the latter to the high Q cavity without a ballast load.

H. J. Krusemeyer

(VII. TUBE RESEARCH AND DEVELOPMENT)

5. 1-Mev Pulsed Electron Source

a. Tube

Construction of the Pierce-gun type diode described in the Quarterly Progress Report, January 15, 1951 has progressed to the point where it is nearly ready for the final assembly.

Tests showed that the proposed filament-cathode assembly consumed considerably more power than anticipated; therefore the length of the cathode cylinder has been shortened to minimize the area of radiation. A 0.0034-inch diameter tungsten wire is being used for the filament in order to reduce filament current and minimize I^2R losses in the aluminum foil transformer secondary windings, through which the filament current must pass. This filament draws 850 ma at 28 volts when the cathode is operating at 830 °C. However, 67 volts must be applied to the grounded side of the split transformer secondary, and a loss of 33 watts results in the transformer alone.

An attempt has been made to obtain a light metal for the electron window which would absorb less energy from the electron beam than would a stainless steel window. A 0.0015-inch thick stainless steel window was held at 450 °C for three days, with no vacuum failure. A titanium window, however, failed after only one hour because of high-temperature creep. While it has not yet been tested, beryllium seems to offer the desired characteristics if a sufficiently thin sheet can be obtained.

A. W. Boekelheide

b. Modulator

A modulator for the high-energy electron source has been designed and is being constructed. It is of the d-c line discharge type and employs a 100-henry charging reactor, two 371B charging diodes in parallel, and a 0.1 mfd storage capacitor. The value of the storage capacitor will have to be adjusted, since it is practically impossible to calculate. This is because the total capacity of the tube, secondary of the pulse transformer, leads, etc., as seen from the primary input terminals, is not at present known. A pair of 5C22 thyratrons operated in parallel will be employed as a switch for the modulator. An 18-kv, 0.3-amp, induction regulated, d-c power supply is being employed to drive the modulator. An A/R range scope whose trigger is amplified by a pulse amplifier will be used to trigger one thyatron. The use of a balanced reactor in the plate circuit of the thyratrons insures firing of both tubes even though only one is triggered. The principal components of the modulator circuit are shown in Fig. VII-9. The balanced reactor has been tested with a pair of 5C22 thyratrons at a pulse width of 1 μ sec and 1000 cps recurrence. Operation was quite satisfactory. The reactor consists of twenty turns of No. 18 copper wire wound over a hypersil core on a form 1-3/4 inches in diameter. The modulator is capable of delivering pulses of 20 kv at

(VII. TUBE RESEARCH AND DEVELOPMENT)

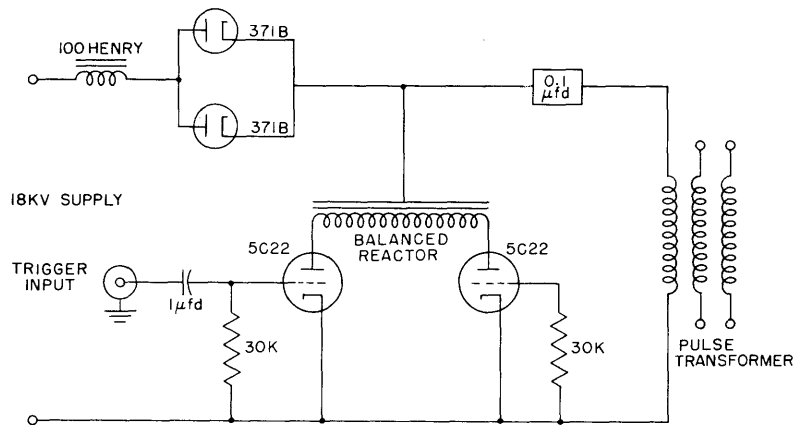

Fig. VII-9 Resonant d-c line charging modulator.

600 amp to the primary of the pulse transformer. At a 50-to-1 step-up this provides the 1-million volt pulse potential for the diode. The limitation to the pulse voltage is due to the thyratrons. This may be increased by a series-parallel arrangement of four tubes if necessary.

L. Roberts