

7-5020-2

# EDDY CURRENT LOSSES IN A CONDUCTING SHAFT ROTATING IN A MAGNETIC FIELD

**N. H. FRANK**

**TECHNICAL REPORT NO. 23**

NOVEMBER 20, 1946

**RESEARCH LABORATORY OF ELECTRONICS**

MASSACHUSETTS INSTITUTE OF TECHNOLOGY

The research reported in this document was made possible through support extended the Massachusetts Institute of Technology, Research Laboratory of Electronics, jointly by the Army Signal Corps, the Navy Department (Office of Naval Research), and the Army Air Forces (Air Materiel Command), under the Signal Corps Contract No. W-36-039 sc-32037.

MASSACHUSETTS INSTITUTE OF TECHNOLOGY  
Research Laboratory of Electronics

Technical Report No. 23

November 20, 1946

EDDY CURRENT LOSSES IN A CONDUCTING SHAFT  
ROTATING IN A MAGNETIC FIELD

by

N. H. Frank

Abstract

The eddy current losses in a shaft rotating in a uniform magnetic field perpendicular to the shaft axis are calculated, when the shielding effect of the induced currents is included. Plots are given to show the increasing distortion of the magnetic field in and around the shaft with increasing ratio of radius to skin depth for the rotation frequency, for non-magnetic shaft material. Formulas are given for the case of magnetic shafts.

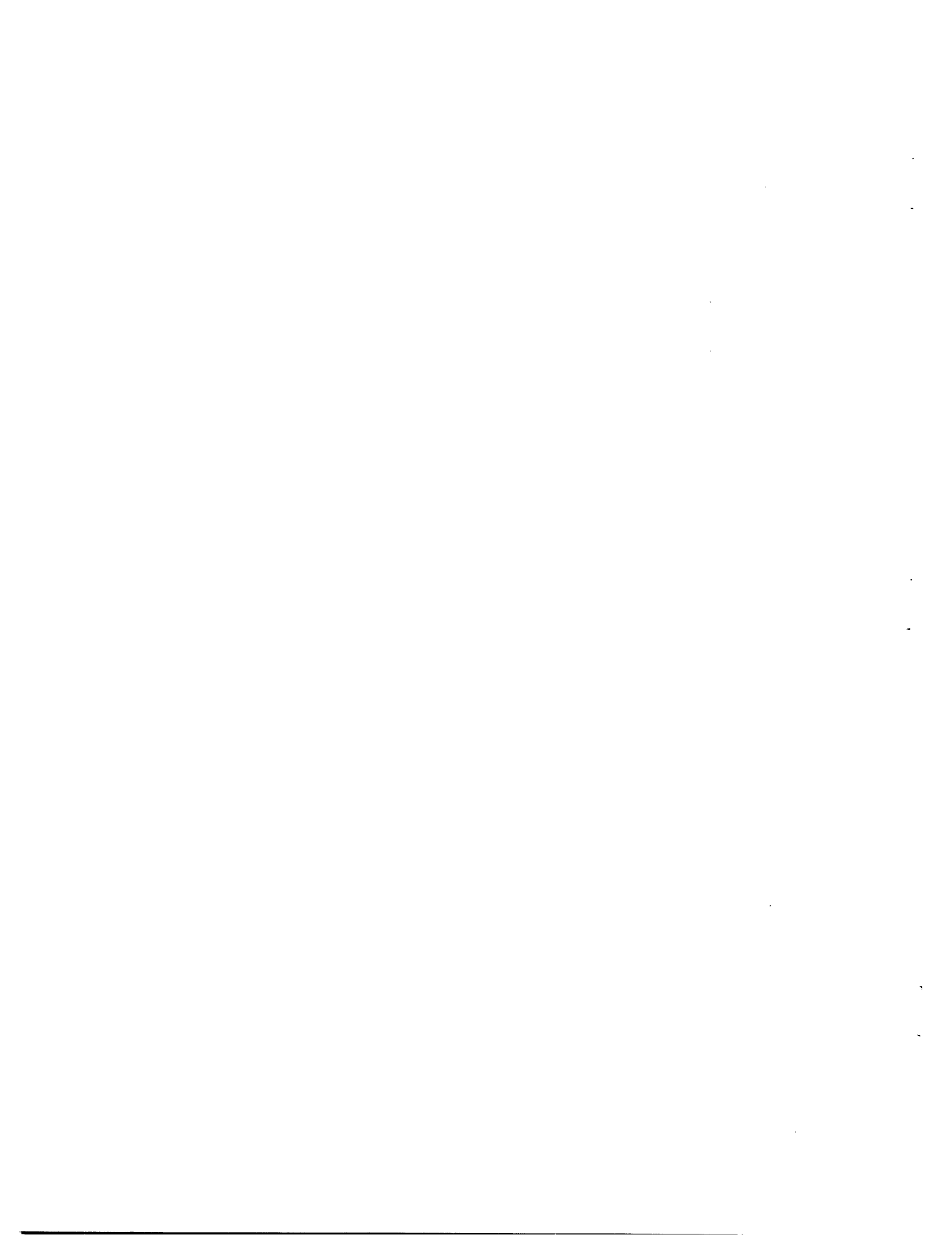

EDDY CURRENT LOSSES IN A CONDUCTING SHAFT  
ROTATING IN A MAGNETIC FIELD

1. In recent design considerations of large synchro-cyclotrons, the problem of computing the eddy current losses in a metal shaft rotating in a uniform magnetic field perpendicular to the shaft axis has arisen. This shaft is used to drive the rotating plates of a variable condenser used to produce the requisite frequency modulation for the dee voltages. Although the solution of this classical problem may exist in the literature of many years ago, it seems worthwhile to make the solution readily available.

Let the metal shaft of radius  $a$  be driven with a constant angular velocity  $\omega$  about its axis (the z-axis), the uniform external magnetic field in the y-direction be  $B_0$ , and consider the shaft sufficiently long compared to its diameter so that end effects may be ignored (Fig. 1).

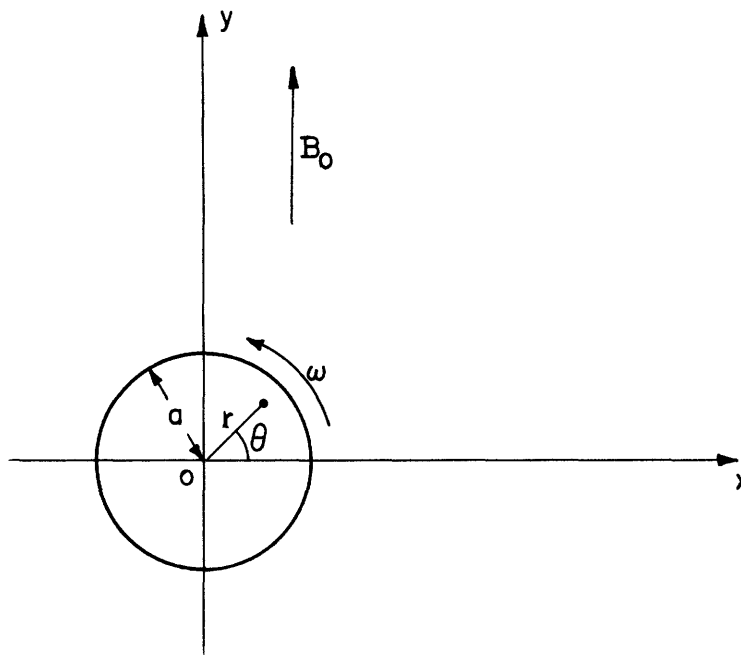

Figure 1. Shaft of radius  $a$  rotating in uniform magnetic field  $B_0$  perpendicular to shaft axis.

There will be induced in the shaft a steady space distribution of currents parallel to the axis, and since it is metallic one may neglect the contribution of the displacement current to the total current. Furthermore, the velocity  $v$  of any point of the shaft is so small compared to the velocity of light that one may use the classical form of Maxwell's equations for moving media. For the problem at hand, since all partial derivatives with respect to time vanish, these take the form

$$\left. \begin{aligned} \text{curl} [\mathbf{E} - (\mathbf{v} \times \mathbf{B})] &= 0 \\ \text{curl} \mathbf{H} &= \sigma \mathbf{E} \end{aligned} \right\} \quad (1)$$

where  $\sigma$  is the conductivity of the metal. These equations are valid inside the shaft. For all exterior points we have the same equations with  $\mathbf{v} = \sigma = 0$ .

At the surface of the rotating shaft, the boundary conditions require the continuity of the tangential and normal components of  $\underline{H}$  and  $\underline{B}$ , respectively. The tangential component of  $\underline{E}$  is, however, discontinuous at this boundary. From the first of Eqs. (1), one has

$$\underline{E} = (\underline{v} \times \underline{B}) - \text{grad } \varphi \quad (2)$$

and since  $(\underline{v} \times \underline{B})$  is everywhere parallel to the shaft axis and end effects are being neglected, we may set the scalar potential  $\varphi$  equal to zero. By inserting Eq. (2) in the second of Eqs. (1), there follows

$$\text{curl } \underline{H} = \sigma (\underline{v} \times \underline{B}); \quad (3)$$

$(\underline{v} \times \underline{B})$  has a z-component equal to  $(-r\omega B_r)$ , the remaining components being zero. We set

$$\underline{B} = \text{curl } \underline{A}, \quad A_z = A(r, \theta); \quad A_r = A_\theta = 0 \quad \text{so that } \text{div } \underline{A} = 0$$

and obtain from Eq. (3)

$$\text{curl curl } \underline{A} = -\nabla^2 \underline{A} = -\mu\sigma\omega \frac{\partial \underline{A}}{\partial \theta} \quad (4)$$

$$\text{since } B_r = \frac{1}{r} \frac{\partial A}{\partial \theta}.$$

In polar coordinates Eq. (4) becomes

$$\frac{1}{r} \frac{\partial}{\partial r} r \frac{\partial A}{\partial r} + \frac{1}{r^2} \frac{\partial^2 A}{\partial \theta^2} - \mu\sigma\omega \frac{\partial A}{\partial \theta} = 0. \quad (4a)$$

This equation holds for  $r < a$ ; for  $r > a$  the vector potential satisfies Laplace's Equation. Since  $\underline{A}$  must be a single-valued function of the angle  $\theta$ , this is not a separable equation. The solutions of Eq. (4a) which are needed are the real and imaginary parts of  $f(r)e^{-j\theta}$ , where  $f(r)$  is the non-singular solution of the Bessel equation.

$$\frac{d^2 f}{dr^2} + \frac{1}{r} \frac{df}{dr} + (jk^2 - \frac{1}{2})f = 0 \quad \text{with } k^2 = \mu\sigma\omega, \quad (4b)$$

$$\text{i.e.} \quad f = J_1(\sqrt{j} kr).$$

Thus we can write for  $r < a$

$$\underline{A} = A_z = B_0 a \left\{ b_1 \text{Re} \left[ \sqrt{j} J_1(\sqrt{j} kr) e^{-j\theta} \right] + b_2 \text{Im} \left[ \sqrt{j} J_1(\sqrt{j} kr) e^{-j\theta} \right] \right\} \quad (5)$$

and for  $r > a$

$$\underline{A} = A_z = -B_0 r \cos\theta + B_0 c_1 \frac{a^2}{r} \cos\theta + B_0 c_2 \frac{a^2}{r} \sin\theta$$

since for large values of  $r$ ,  $\underline{A}$  must go over to  $-B_0 x = -B_0 r \cos\theta$ .

$$\text{If we now set } \rho = kr, \quad \rho_0 = ka, \quad \text{and } \sqrt{j} J_1(\sqrt{j}\rho) = u_1(\rho) + jv_1(\rho),$$

Eqs. (5) become:

$$\left. \begin{aligned} r < a \quad \underline{A} &= B_0 a \left[ \cos\theta \left\{ b_1 u_1(\rho) + b_2 v_1(\rho) \right\} + \sin\theta \left\{ b_1 v_1(\rho) - b_2 u_1(\rho) \right\} \right] \\ r > a \quad \underline{A} &= B_0 a \left[ \cos\theta \left\{ -\frac{\rho}{\rho_0} + \frac{\rho_0}{\rho} c_1 \right\} + c_2 \frac{\rho_0}{\rho} \sin\theta \right]. \end{aligned} \right\} \quad (6)$$

The continuity of tangential  $\underline{H}$  and normal  $\underline{B}$  at  $r = a$ , ( $\rho = \rho_0$ ) then provide the necessary equations to determine the dimensionless constants  $b_1$ ,  $b_2$ ,  $c_1$ , and  $c_2$ . For the sake of simplicity, let us consider first the case of a non-magnetic shaft; i.e.,  $\mu = \mu_0$ . This solution is of interest in the cyclotron application, since there the

external field  $\underline{E}_0$  is so large that saturation conditions would exist in a steel shaft. From the continuity of  $\frac{\partial A}{\partial \rho}$  and  $\frac{1}{\rho} \frac{\partial A}{\partial \theta}$ , one obtains the equations

$$\begin{aligned} c_1 &= 1 + b_1 u_1(\rho_0) + b_2 v_1(\rho_0); & c_2 &= b_1 v_1(\rho_0) - b_2 u_1(\rho_0) \\ b_1 [u_1(\rho_0) + \rho_0 u_1'(\rho_0)] + b_2 [v_1(\rho_0) + \rho_0 v_1'(\rho_0)] &= -2 & (7) \\ b_1 [v_1(\rho_0) + \rho_0 v_1'(\rho_0)] - b_2 [u_1(\rho_0) + \rho_0 u_1'(\rho_0)] &= 0 \end{aligned}$$

where the primes denote differentiation with respect to  $\rho$ . From the general relation

$$J_1(z) + z \frac{d}{dz} \{J_1(z)\} = zJ_0(z)$$

there follows

$$\left. \begin{aligned} u_1(\rho) + \rho u_1'(\rho) &= -\rho v_0(\rho) \\ v_1(\rho) + \rho v_1'(\rho) &= +\rho u_0(\rho) \end{aligned} \right\} \quad (8)$$

where we have written  $J_0(\sqrt{j}\rho) = u_0(\rho) + jv_0(\rho)$ .

Using Eqs. (8) in Eqs. (7), one finds readily for the constants,

$$\left. \begin{aligned} b_1 &= \frac{2}{\rho_0} \frac{v_0}{u_0^2 + v_0^2}; & b_2 &= -\frac{2}{\rho_0} \frac{u_0}{u_0^2 + v_0^2} \\ c_1 &= 1 + \frac{2}{\rho_0} \frac{u_1 v_0 - u_0 v_1}{u_0^2 + v_0^2} \\ c_2 &= \frac{2}{\rho_0} \frac{u_0 u_1 + v_0 v_1}{u_0^2 + v_0^2} \end{aligned} \right\} \quad (9)$$

where the constants  $u_1, v_1, u_0,$  and  $v_0$  are the values of the functions at  $\rho = \rho_0$ .

The equations of the field lines of  $\underline{E}$  may be obtained as follows:

Since  $E_r = \frac{1}{r} \frac{\partial A}{\partial \theta}$  and  $E_\theta = -\frac{\partial A}{\partial r}$ , one has

$$\frac{B_r}{B_\theta} = \frac{dr}{r d\theta} = -\frac{1}{r} \frac{\partial A / \partial r}{\partial A / \partial \theta}$$

or

$$\frac{\partial A}{\partial r} dr + \frac{\partial A}{\partial \theta} d\theta = 0.$$

Hence

$$A(r, \theta) = \text{const.} \quad (10)$$

gives the field lines.

By using the constants given by Eqs. (9) in Eqs. (6), there follow

$$\left. \begin{aligned} \rho < \rho_0 \\ r < a \\ \rho > \rho_0 \\ r > a \end{aligned} \right\} \left. \begin{aligned} \left[ v_1(\rho) - \frac{v_0(\rho_0)}{u_0(\rho_0)} u_1(\rho) \right] \cos\theta - \left[ u_1(\rho) + \frac{v_0(\rho_0)}{u_0(\rho_0)} v_1(\rho) \right] \sin\theta &= c_1 \\ \left[ -\frac{\rho}{\rho_0} + \frac{\rho_0}{\rho} + \frac{2}{\rho} \left\{ \frac{u_1(\rho_0)v_0(\rho_0) - u_0(\rho_0)v_1(\rho_0)}{u_0^2(\rho_0) + v_0^2(\rho_0)} \right\} \right] \cos\theta \\ + \frac{2}{\rho} \left[ \frac{u_0(\rho_0)u_1(\rho_0) + v_0(\rho_0)v_1(\rho_0)}{u_0^2(\rho_0) + v_0^2(\rho_0)} \right] \sin\theta &= c_2 \end{aligned} \right\} \quad (11)$$

which determine the field pattern. Figures 2, 3, and 4 show plots for the typical cases  $\rho_0 = ka = \frac{1}{2}, 2.5, \text{ and } 10$ .

2. The eddy current power loss per unit length of the shaft is now obtained as follows:

The power loss per unit volume is, with the help of Eq. (6),

$$\sigma E^2 = \sigma \omega^2 r^2 B_r^2 = \sigma \omega^2 \left( \frac{\partial A}{\partial \theta} \right)^2 = \sigma \omega^2 B_0^2 a^2 \left[ \cos \theta \{ b_1 v_1(\rho) - b_2 u_1(\rho) \} - \sin \theta \{ b_1 u_1(\rho) + b_2 v_1(\rho) \} \right]^2.$$

The integration over  $\theta$  from 0 to  $2\pi$  gives a factor  $\pi$  for the  $\cos^2 \theta$  and  $\sin^2 \theta$  terms and the product term integrates to zero. Thus one obtains for the power loss per unit length

$$P = \pi \sigma \omega^2 B_0^2 a^2 (b_1^2 + b_2^2) \int_0^a r [u_1^2(\rho) + v_1^2(\rho)] dr \quad (12)$$

and since from Eqs. (9) one has

$$b_1^2 + b_2^2 = \frac{4}{\rho_0^2} \frac{1}{u_0^2(\rho_0) + v_0^2(\rho_0)},$$

this can be written as

$$P = \frac{\pi \sigma \omega^2 B_0^2 a^4}{4} F(\rho_0) = P_0 F(\rho_0) \quad (12a)$$

where

$$F(\rho_0) = \left( \frac{2}{\rho_0} \right)^4 \frac{\int_0^{\rho_0} \rho |J_1(\sqrt{J} \rho_0)|^2 d\rho}{|J_0(\sqrt{J} \rho_0)|^2}.$$

The integral can be evaluated by elementary methods and the final result is:

$$F(\rho_0) = -2 \left( \frac{2}{\rho_0} \right)^3 \left[ \frac{u_0(\rho_0)u_1(\rho_0) + v_0(\rho_0)v_1(\rho_0)}{u_0^2(\rho_0) + v_0^2(\rho_0)} \right]. \quad (13)$$

The function  $F(\rho_0)$  is essentially the shielding function, since the factor  $P_0$  in Eq. (12a) is the dissipation per unit length which would result from the uniform field  $B_0$  if one ignores the shielding action of the induced currents.

Figure 5 shows the function  $F(ka)$  vs.  $(ka)$  and shows how the losses fall off sharply as  $ka$  increases,  $ka$  is  $\sqrt{2}$  times the ratio of shaft radius to skin depth at the angular frequency  $\omega$ . For small values of  $ka$ , the power series expansions of the Bessel functions give

$$F(ka) = 1 - \frac{11}{12} \left( \frac{ka}{2} \right)^4 = 1 - 0.0286(ka)^4 \quad (13a)$$

showing the extraordinary lack of shielding for small ratios of radius to skin depth.

For large values of  $ka$ , the asymptotic forms of the Bessel functions give

$$F(ka) \rightarrow \sqrt{2} \left( \frac{2}{ka} \right)^3 \quad \text{as } ka \rightarrow \infty. \quad (13b)$$

Thus for large ratios of radius to skin depth, Eq. (12a) gives for the power loss per unit length

$$P = 2\pi a \left( \frac{B_0^2}{\mu} \right) \sqrt{\frac{2\omega}{\mu\sigma}}.$$



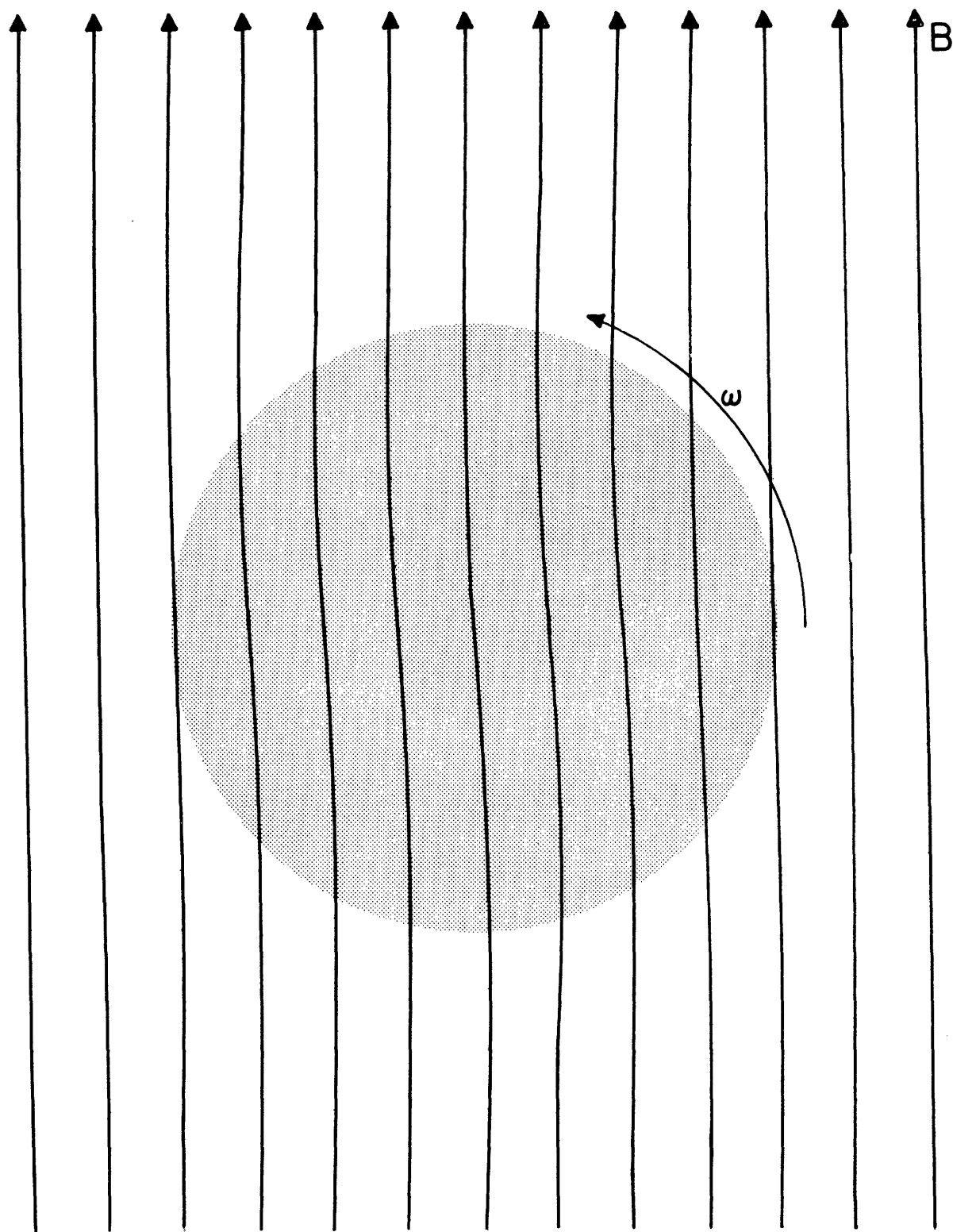

Figure 2. Magnetic field pattern for  $\rho_p = ka = 0.5$  where  $k = \sqrt{\mu_0 \sigma \omega}$  and  $a =$  shaft radius. The shaded area represents the cross section of the rotating shaft.

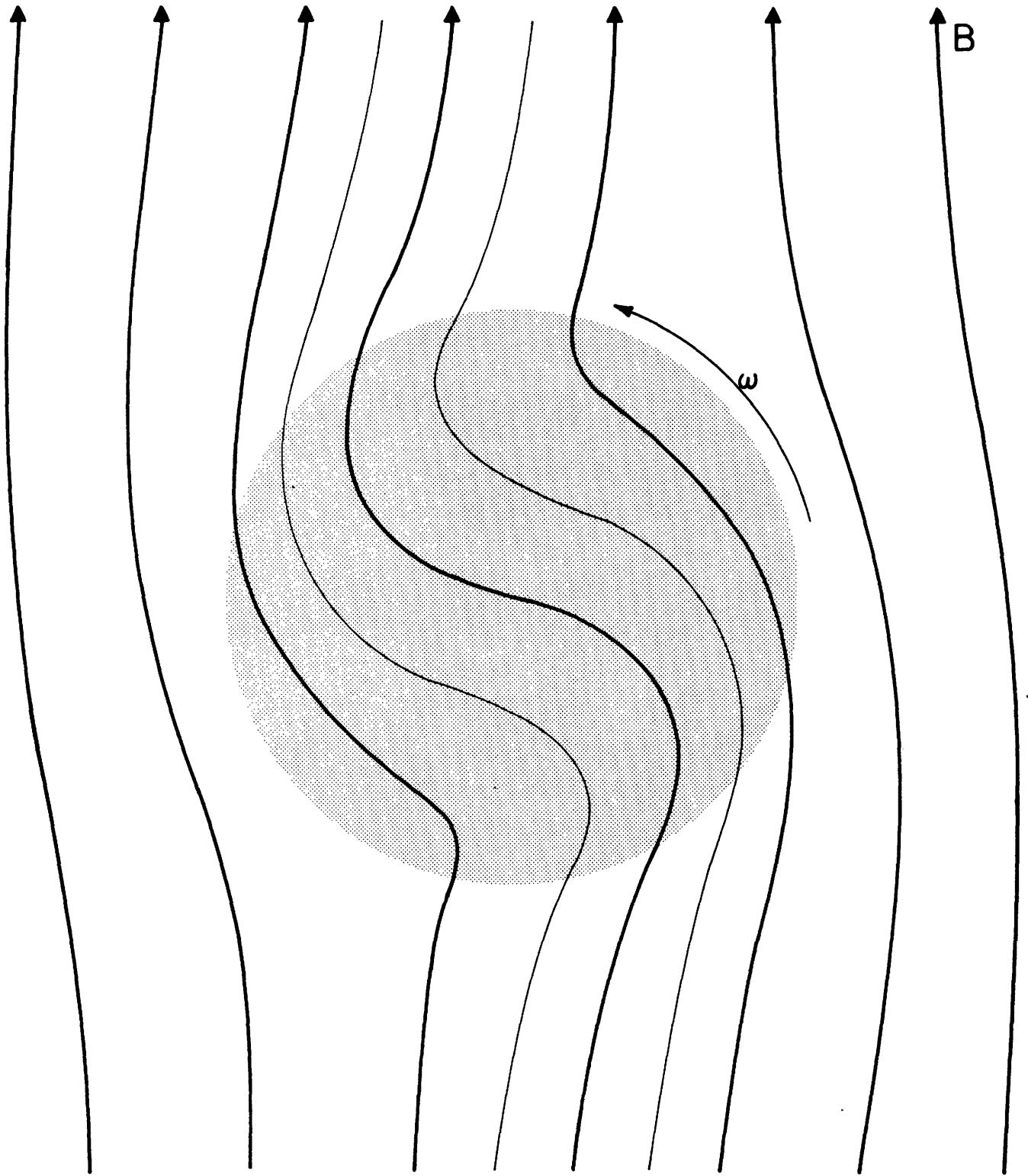

Figure 3. Magnetic field pattern for  $\rho_0 = ka = 2.5$  where  $k = \sqrt{\mu_0 \sigma \omega}$  and  $a =$  shaft radius. The shaded area represents the cross section of the rotating shaft.

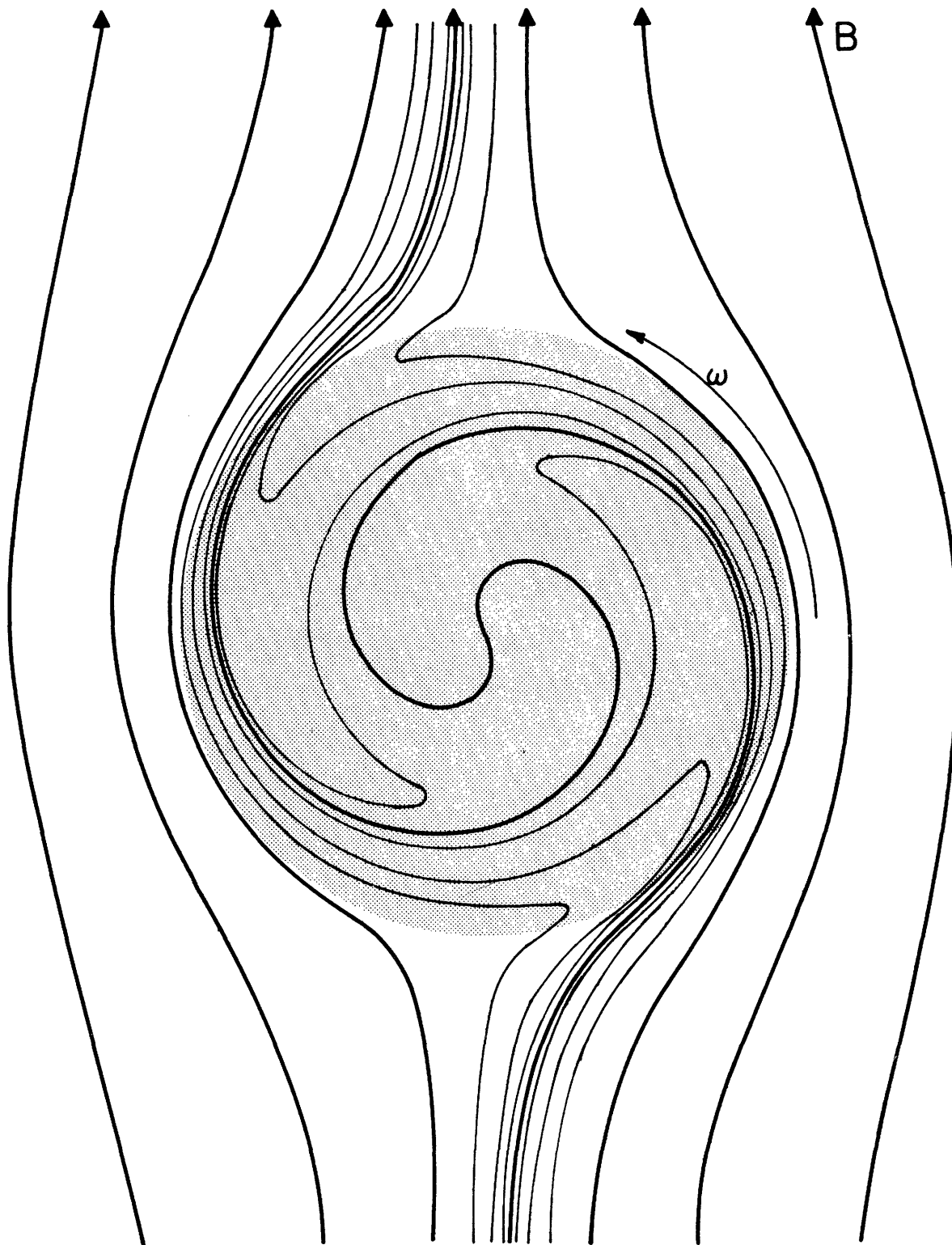

Figure 4. Magnetic field pattern for  $\rho_0 = ka = 10$  where  $k = \sqrt{\mu_0 \sigma \omega}$  and  $a =$  shaft radius. The shaded area represents the cross section of the rotating shaft. The heavy lines correspond to uniformly spaced lines of  $B_0$ . The lighter lines are inserted to show the detailed behavior of the field inside the shaft.

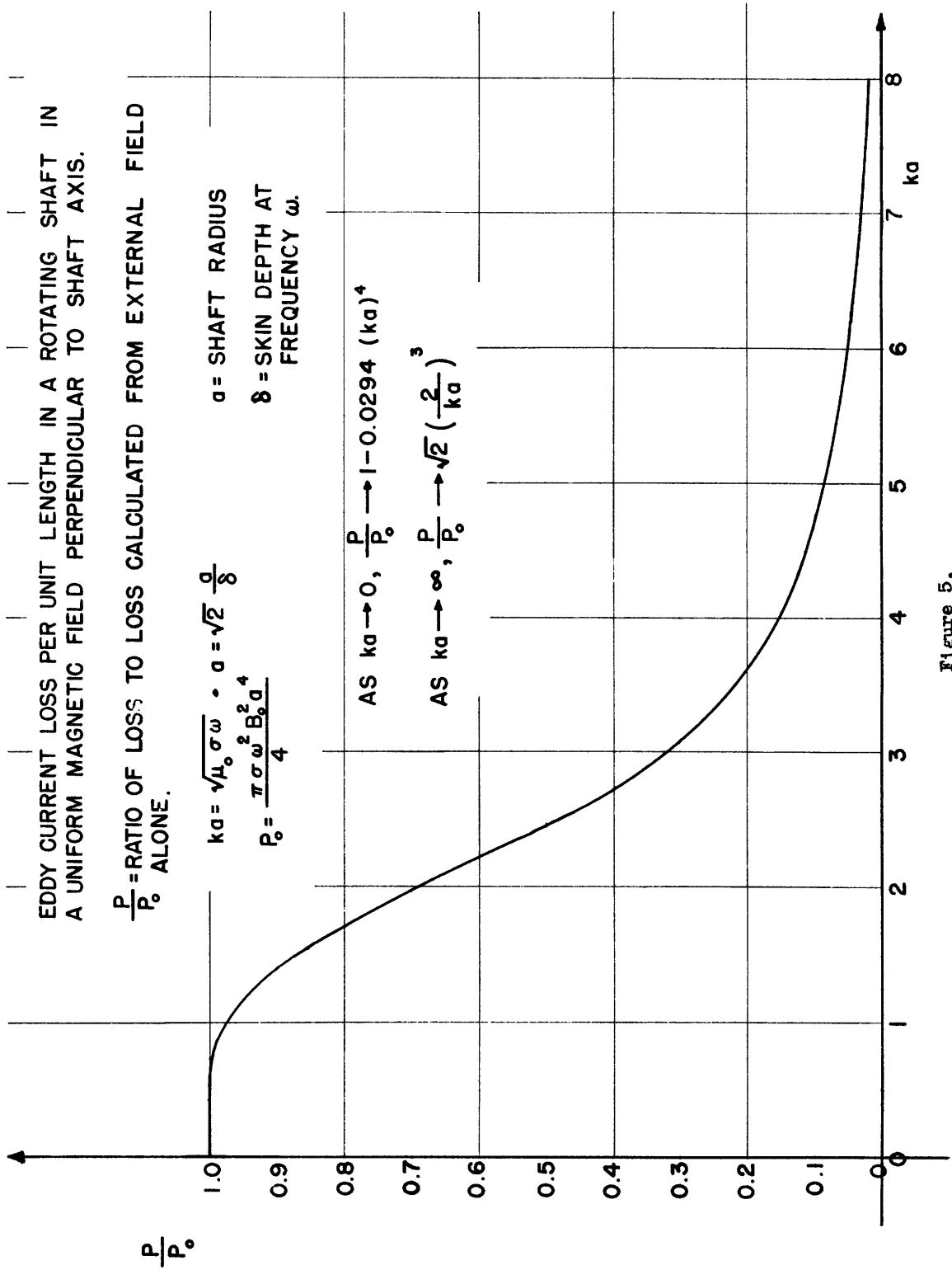

Figure 5.

3. In the case of a shaft of permeability  $\mu \neq \mu_0$ , assumed constant, we must have continuity of  $\frac{1}{\rho} \frac{\partial A}{\partial \theta}$  and of  $\frac{1}{\mu} \frac{\partial A}{\partial r}$  at  $r = a$  ( $\rho = \rho_0$ ). From Eq. (6) one then finds the following values of the constants in place of Eq. (9).

$$\begin{aligned}
 b_1 &= \frac{\frac{2v_0}{\rho_0} \frac{\mu}{\mu_0} \left[ 1 - \frac{u_1}{\rho_0 v_0} \left( \frac{\mu}{\mu_0} - 1 \right) \right]}{u_0^2 \left[ 1 + \frac{v_1}{\rho_0 u_0} \left( \frac{\mu}{\mu_0} - 1 \right) \right]^2 + v_0^2 \left[ 1 - \frac{u_1}{\rho_0 v_0} \left( \frac{\mu}{\mu_0} - 1 \right) \right]^2} ; \\
 b_2 &= \frac{-2 \frac{u_0}{\rho_0} \frac{\mu}{\mu_0} \left[ 1 + \frac{v_1}{\rho_0 u_0} \left( \frac{\mu}{\mu_0} - 1 \right) \right]}{u_0^2 \left[ 1 + \frac{v_1}{\rho_0 u_0} \left( \frac{\mu}{\mu_0} - 1 \right) \right]^2 + v_0^2 \left[ 1 - \frac{u_1}{\rho_0 v_0} \left( \frac{\mu}{\mu_0} - 1 \right) \right]^2} \\
 c_1 &= 1 + \frac{\frac{2}{\rho_0} \frac{\mu}{\mu_0} \left[ (v_0 u_1 - u_0 v_1) - \frac{u_1^2 + v_1^2}{\rho_0} \left( \frac{\mu}{\mu_0} - 1 \right) \right]}{u_0^2 \left[ 1 + \frac{v_1}{\rho_0 u_0} \left( \frac{\mu}{\mu_0} - 1 \right) \right]^2 + v_0^2 \left[ 1 - \frac{u_1}{\rho_0 v_0} \left( \frac{\mu}{\mu_0} - 1 \right) \right]^2} \\
 c_2 &= \frac{\frac{2}{\rho_0} \frac{\mu}{\mu_0} (u_0 u_1 + v_0 v_1)}{u_0^2 \left[ 1 + \frac{v_1}{\rho_0 u_0} \left( \frac{\mu}{\mu_0} - 1 \right) \right]^2 + v_0^2 \left[ 1 - \frac{u_1}{\rho_0 v_0} \left( \frac{\mu}{\mu_0} - 1 \right) \right]^2}
 \end{aligned} \tag{9a}$$

where the constants  $u_0$ ,  $u_1$ ,  $v_0$ , and  $v_1$  are the values of the functions at  $\rho = \rho_0$ . The eddy current loss per unit length and the equations for the lines of B may then be obtained by using the constants given by (9a) in Eqs. (12) and (6).

