

DETERMINATION OF NAVAL MEDIUM SPEED DIESEL ENGINE AIR EXHAUST  
EMISSIONS AND VALIDATION OF A PROPOSED ESTIMATION MODEL

by

Agnes M. Mayeaux

B.S. Ocean Engineering, United States Naval Academy (1986)

Submitted to the Department of Ocean Engineering and Department of Mechanical Engineering in  
Partial Fulfillment of the Requirements for the Degrees of

NAVAL ENGINEER

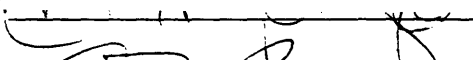
and

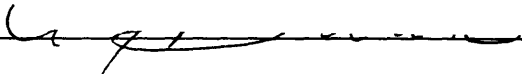
MASTER OF SCIENCE IN MECHANICAL ENGINEERING

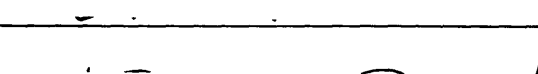
at the  
Massachusetts Institute of Technology  
May 1995

© 1995 Aggie Mayeaux. All rights reserved.

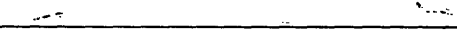
The author hereby grants to MIT, the United States Government and its agencies permission to  
reproduce and to distribute publicly paper and electronic copies of this thesis document in whole or in part.

Signature of Author.  Department of Ocean Engineering

Certified by  Professor Alan J. Brown  
Thesis Advisor

Certified by  Victor W. Wong, Ph.D.  
Thesis Advisor

Accepted by  Professor A. Douglas Carmichael  
Chairman, Graduate Committee  
Department of Ocean Engineering

Accepted by  Professor Ain A. Sonin  
Chairman, Graduate Committee  
Department of Mechanical Engineering

MASSACHUSETTS INSTITUTE  
OF TECHNOLOGY

JUL 28 1995

LIBRARIES  
Barker Eng

# **Determination of Naval Medium Speed Diesel Engine Air Exhaust Emissions and Validation of a Proposed Estimation Model**

by

**Agnes Mae Mayeaux**

Submitted to the Department of Ocean Engineering  
in Partial Fulfillment of the Requirements for the Degrees of Naval Engineer and  
Masters of Science in Mechanical Engineering

## **ABSTRACT**

Steady state marine diesel engine exhaust emissions are being reviewed by the Environmental Protection Agency for possible regulation. In anticipation of future regulation, the United States Navy is developing appropriate emissions models for naval vessels. Actual emissions data from a U.S. Navy ship is necessary to provide checkpoints for the models. A procedure for collecting this data from an U.S. Navy ship with medium speed main propulsion diesels is presented. It is based on similar testing conducted by the U.S. Coast Guard for measuring patrol boat diesel engine emissions and International Standards Organization methodology. The primary challenge of the experiment design was to minimize interference with the engineering plant as the assigned ship was concurrently tasked for other operations. Data gathered allowed calculation of engine rpm, engine load, exhaust gas flow rate and determination of pollutant amounts. The tests were conducted at a series of predetermined speeds to reflect an 11-Mode duty cycle developed previously for the LSD 41 Class propulsion diesel engines. The results add to a growing data base of marine emissions and offer insight into the effects of secondary control factors such as sea conditions, maneuvering and continued reactions in the stack.

Additional work is included which models an appropriate duty cycle for U.S. Navy high speed propulsion diesel engines found on the MCM-1 Class Mine Countermeasure Ship. The results indicate that not only are the duty cycles developed for commercial ship operations inadequate for modeling of naval ship operations, but that the naval duty cycles will vary greatly by mission.

Thesis Supervisor: Dr. Alan J. Brown  
Title: Professor  
Department of Ocean Engineering

Thesis Supervisor: Dr. Victor W. Wong  
Title: Lecturer  
Manager, Sloan Automotive Laboratory  
Department of Mechanical Engineering

## Acknowledgements

On a professional level, there were a large number of people without who's assistance this thesis could not have been completed. I am not certain I can adequately cover the extensive roll and apologize to those who deserve much credit but are missed in the following list. Special thanks to:

My advisors, Captain Alan Brown and Dr. Victor Wong.

Dr. Bentz and Dr. Allen of the Coast Guard R&D Center, who shared the woes of planning and executing the testing of a LSD-41 Class ship. Also thanks to Doug Griggs (NSWC, Carderock) and Mike Iacovelli (NAVSSSES) for their good humor, advice and cough drops.

Ed Merry, Ed Epperly and the SUPSHIP Portsmouth crew who assisted in arranging instrumentation for the ship testing.

The entire crew of the USS ASHLAND, LSD-48 for their warm hospitality and willing co-operation during sea trials in February of 1995. A special acknowledgement to LT Billie Walden, a dedicated and talented officer who serves as a role-model for all fortunate enough to sail with her. And a personal note for CDR Mike Hlywiak: the next time we sail together again, I hope the length of the boat is only 36 feet.

Thank-you members of the Mine Warfare Command in Ingleside, Texas. With your help and that of the crews of USS ARDENT, USS WARRIOR and USS GLADIATOR, I quickly and effortlessly gathered seventy pounds of raw data from which to develop the MCM-1 Class operating profile. Tony, your hospitality and insight was especially appreciated.

LCDR Al Gaiser of RESUPSHIP, Ingleside provided excellent information regarding the operation of and future developments in design of the Isotta Fraschini diesel engine. MM1 Dole, the token Machinist Mate of the command, also deserves a round of applause for his unselfish co-operation.

On the personal side, there are numerous names which come to mind. Special thanks to Tim McCoy and Melissa Smoot, for sanity checks and timely advice. Melissa, an excellent hostess as always, also performed wonderfully as the most effective gopher I ever had (just kiddin'). She is a wonderful friend.

To Grainne and Theresa for relieving long hours of tedium.

I must mention my constant companions during the writing of this work: Matou and Chicot. While short on conversation, they did help curb the depression of loneliness.

Conversation was forced onto two unfortunate souls: my sister Alice (better known as Leroy) and Jennifer. Thank-you for your patience and understanding.

And, of course, Michael...

# TABLE OF CONTENTS

ABSTRACT .....	2
ACKNOWLEDGEMENTS .....	3
TABLE OF CONTENTS .....	4
LIST OF FIGURES .....	6
LIST OF TABLES .....	8
Chapter 1 Introduction .....	9
1.1 Purpose .....	9
1.2 Current Regulatory Stance .....	10
1.3 Motivation .....	16
1.4 Thesis Outline .....	17
<b>SECTION 1: MCM-1 CLASS OPERATING PROFILE</b>	
Chapter 2 MCM-1 Class Description and Operating Profile .....	20
2.1 Hull and Propulsion Plant Description .....	20
2.2 Ship Powering Curve .....	24
2.3 Standard Bell Order Table .....	26
2.4 MCM-1 Class Ship operation .....	30
Chapter 3 MCM-1 Class Duty Cycle and Comparison .....	39
3.1 MCM-1 Class Duty Cycles .....	39
3.2 MPDE Duty Cycle Comparisons .....	43
3.3 SSDG Duty Cycle Comparisons .....	49
3.4 Duty Cycle Conclusions .....	52
<b>SECTION 2: LSD-41 CLASS EMISSIONS MEASUREMENT</b>	
Chapter 4 Experimental Set-up .....	54
4.1 Discussion of Previous Work .....	54
4.2 Experimental Goals .....	60
4.3 Experimental Constraints .....	62

<b>Chapter 5</b>	<b>Analysis and Results</b> .....	<b>70</b>
5.1	<b>Analysis Approach</b> .....	<b>70</b>
5.2	<b>Discussion of Results</b> .....	<b>75</b>
<b>Chapter 6</b>	<b>Conclusions and Recommendations</b> .....	<b>86</b>
<b>REFERENCES</b>	.....	<b>89</b>
<b>Appendix A</b>	<b>Sample Logs</b> .....	<b>93</b>
<b>Appendix B</b>	<b>Log Review Summaries</b> .....	<b>95</b>
<b>Appendix C</b>	<b>MPDE and SSDG Emission Prediction Data</b> .....	<b>110</b>
<b>Appendix D</b>	<b>Experimental Instrumentation</b> .....	<b>125</b>
<b>Appendix E</b>	<b>Test Plan</b> .....	<b>149</b>
<b>Appendix F</b>	<b>Trial Report</b> .....	<b>162</b>
<b>Appendix G</b>	<b>LSD-48 Emissions Measurement Results</b> .....	<b>181</b>

## **List of Figures:**

Figure 1	Breakdown of Nonroad Sources of NO <sub>x</sub>	11
Figure 2	Maximum Allowable NO <sub>x</sub> Emissions for Marine Diesel Engines	15
Figure 3	USS SCOUT (MCM-8), Port Bow View	20
Figure 4	MCM-1 Class Body Plan	21
Figure 5	Isotta Fraschini SS6 V-AM, Right Front View	23
Figure 6	MCM-1 Class Powering Curve	25
Figure 7	Ship Speed Ahead versus RPM and Pitch	28
Figure 8	Operating Profile Analysis Flow Chart	34
Figure 9	MCM-1 Class Composite Operating Profile	35
Figure 10	LSD-41 Class Composite Speed Operating Profile	36
Figure 11	Composite Operating Profile Cumulative Time Factor Comparison	36
Figure 12	MCM-1 Class SSDG Operating Profile	38
Figure 13	Naval Ship Duty Cycle Determination	40
Figure 14	Duty Cycle Engine Speed and Power Points	42
Figure 15	Pielstick PA4-200-VGA NO <sub>x</sub> Emission Contour Map	44
Figure 16	Pielstick PA-4-200-VGA CO Emission Contour Map	44
Figure 17	Pielstick PA-4-200-VGA Gaseous HC Emission Contour Map	45
Figure 18	MPDE NO <sub>x</sub> Prediction Comparison (g/bhp-hr)	47
Figure 19	MPDE CO Prediction Comparison (g/bhp-hr)	48
Figure 20	MPDE Gaseous HC Prediction Comparison (g/bhp-hr)	48
Figure 21	SSDG NO <sub>x</sub> Prediction Comparison (g/bhp-hr)	50
Figure 22	SSDG CO Prediction Comparison (g/bhp-hr)	51
Figure 23	SSDG Gaseous HC Prediction Comparison (g/bhp-hr)	51
Figure 24	Lloyd's Register CO Results	55
Figure 25	Lloyd's Register NO <sub>x</sub> Results	56
Figure 26	Coast Guard Normalized NO <sub>x</sub> Data	58
Figure 27	Sketch of Intake Air Piping in Uptake Room	64
Figure 28	Volumetric Air Flow Rate versus Engine Load	71
Figure 29	Specific Emissions Analysis Flowpath	73
Figure 30	Equivalence Ratio versus Engine Load	76
Figure 31	NO <sub>x</sub> (ppm) versus Engine BMEP	77
Figure 32	CO (ppm) versus Engine BMEP	79
Figure 33	NO <sub>x</sub> (g/Kg fuel) versus Engine Load	81
Figure 34	Lloyd's Register NO <sub>x</sub> Results for Engines with MCR>4000 kW	81
Figure 35	CO (g/Kg fuel) versus Engine Load	82
Figure 36	Lloyd's Register CO Results for Engines with MCR>4000 kW	82
Figure 37	NO <sub>x</sub> Specific Emissions versus Engine Load	84
Figure A-1	Ship Deck Log Sheet	93
Figure A-2	Engineering Log Sheet	94
Figure B-1	Comparison of Results from USS ARDENT and ARDENT (x)	97
Figure B-2	USS GLADIATOR MPDE Time Factors	99

Figure B-3	USS GLADIATOR Summary MPDE Composite Operating Profile	100
Figure B-4	USS ARDENT MPDE Time Factors	102
Figure B-5	USS ARDENT Summary MPDE Composite Operating Profile	103
Figure B-6	USS WARRIOR MPDE Time Factors	105
Figure B-7	USS WARRIOR Summary MPDE Composite Operating Profile	106
Figure B-8	Comparison Plot of MCM-1 Class MPDE Operating Profiles	108
Figure B-9	Comparison Plot of MCM-1 Class MPDE Time Factors	109
Figure C-1	MCM-1 Operating Profile (One Engine Per Shaft)	114
Figure C-2	MCM-1 Operating Profile (Two Engines per Shaft)	115
Figure C-3	MCM-1 MPDE Duty Cycle	116
Figure C-4	ISO 8178 Duty Cycle E-5	117
Figure C-5	ISO 8178 Duty Cycle E3	118
Figure C-6	CARB 8-Mode Duty Cycle	119
Figure C-7	ICOMIA Heavy-Duty Diesel Duty Cycle	120
Figure C-8	MCM-1 SSDG Operating Points	121
Figure C-9	ISO 8178 Duty Cycle D2	122
Figure C-10	ISO 8178 Duty Cycle C-1	123
Figure C-11	MCM-1 SSDG Duty Cycle	124
Figure D-1	Machinery Room #1 Instrumentation Layout	126
Figure D-2	Uptake Space Instrumentation Layout	127
Figure D-3	ACCUTUBE Installation	129
Figure D-4	Distant View of Fuel Flow Meter (MPDE 1A Supply)	135
Figure D-5	Close View of Fuel Flow Meters (MPDE 1A Supply and 1B Return)	136
Figure D-6	Uptake Space Entry (From Inside Space)	137
Figure D-7	Mounting Board with Pressure Transducers, Meters and Power Supplies	137
Figure D-8	Near and Distant Views of Pitot Views (MPDE 1B Intake)	138
Figure D-9	Thermocouple and Pressure Transducer Tubing (MPDE 1A Intake)	139
Figure D-10	Automated Data Collection Station (Main Control)	139
Figure D-11	Valve and ECOM Probe Being Positioned (MPDE 1B Exhaust Piping)	140
Figure D-12	Pressure Transducer Calibration Curve	141
Figure D-13	Pressure Transducer Calibration Set-up	142
Figure D-14	ECTRON Amplifier Calibration Curves	143
Figure D-15	Thermocouple Calibration Curves	144
Figure D-16	Engine 1A Supply and Return Fuel Flow Meter Calibration Plot	147
Figure D-17	Engine 1B Supply and Return Fuel Flow Meter Calibration Plot	148
Figure G-1	Engine BHP Correlation	188
Figure G-2	Volumetric Fuel Flow Rate versus Engine Load	189
Figure G-3	NO <sub>x</sub> (ppm) Differentiated by Plant Alignment	193
Figure G-4	NO <sub>x</sub> (ppm) Differentiated by Day of Testing	194
Figure G-5	NO <sub>x</sub> (ppm) Differentiated by Engine	195

## **List of Tables:**

Table 1	Sampling of ISO 8178-4 RIC Duty Cycles	18
Table 2	MCM-1 Class Hull Dimensions	21
Table 3	Isotta Fraschini Diesel Engine Parameters	22
Table 4	Standardization Trials Results	25
Table 5	Standard Bell Order Table	30
Table 6	MCM-1 Class Ship Data Summary	32
Table 7	MCM-1 Class Composite Operating Profile Time Factors	33
Table 8	MCM-1 Class SSDG Operating Profile Time Factors	38
Table 9	MCM-1 Class MPDE Duty Cycle	41
Table 10	MCM-1 Class SSDG Duty Cycle	42
Table 11	MPDE Duty Cycle Emission Prediction Summary	45
Table 12	SSDG Duty Cycle Emission Prediction Summary	49
Table 13	Comparison of Colt-Pielstick PC4.2B and PC2.5V16 Diesel Engines	59
Table 14	LSD 41 Class Emission Predictions (g/bhp-hr)	60
Table 15	List of Operating Points (Converted to Speeds)	66
Table 16	Run Sequence (Single Engine Per Shaft)	67
Table 17	Run Sequence (Two Engines Per Shaft)	68
Table 18	Specific Emissions Comparison for Pielstick PC4.2B and PC2.5V Engines	85
Table B-1	MCM-1 Class Ship Data Summary	95
Table B-2	USS GLADIATOR MPDE Time Factor Summary	98
Table B-3	USS ARDENT MPDE Time Factor Summary	101
Table B-4	USS WARRIOR MPDE Time Factor Summary	104
Table B-5	Composite Time Factor Calculations	107
Table C-1	MCM-1 MPDE and SSDG Emission Predictions	111
Table D-1	ISO 8178 Accuracy Requirements	125
Table D-2	Pressure Transducer Calibration Information	143
Table D-3	Calibration Constant for Thermocouples and Amplifiers	144
Table D-4	ECOM Analyzer Calibration Data	146
Table E-1	List of Operating Points (Converted to Speeds)	157
Table E-2	Random Run Orders for Single Engine Configurations	158
Table E-3	Rando Run Orders for Dual Engine Configurations	159
Table F-1	Revised Test Blocks of Runs	166
Table F-2	Results of Fuel Analysis	171
Table G-1	Partial Pressure and Absolute Humidity Calculations	182
Table G-2	Temperature Calculations	184
Table G-3	Summary Data from Sea Trials	186
Table G-4	Calculation of Specific Emissions	190
Table G-5	Comparison of Exhaust Flow Rates Due to Input Data Variations	192



## **CHAPTER 1: INTRODUCTION**

### **1.1 Purpose**

With the passage of the Clean Air Act as amended in 1990, regulations regarding limits on the amounts of pollutants discharged as a result of chemical processes were no longer restricted to stationary sources and motor vehicles. The act required the Environmental Protection Agency (EPA) to determine the contributions of off-road moving sources and, if these contributions proved to be significant, regulate these sources as well. This measure was an attempt to spread the costs of developing and implementing "clean" technologies over a larger population of industries.

Recent legislative activity and research has been directed towards air pollution contributions from off-road sources, including marine engines. As a result, regulation of construction and farm equipment, snowmobiles, lawn mowers, etc. has been enacted. The regulation of the marine industry, including major ships as well as pleasure craft, has lagged which can be attributed to the complexities of ship designs and operation.

As interest in the reduction of air pollution from marine exhaust increases, so must the level of knowledge. Further effort is needed to determine the factors which differentiate marine engine exhaust from that of other exhaust sources. Additionally, the unique operation and design of public sector vessels may necessitate testing and control philosophies different from commercial ships.

This study continues work to develop a Naval marine diesel engine exhaust emissions model. It consists of two parts: 1) development of a representative duty cycle and prediction of annual pollutant levels for a U.S. Navy ship propelled by high speed diesel engines, and 2) reduction of measured data from an U.S. Navy vessel with medium speed main propulsion diesel engines. The prediction of annual pollutant levels for a medium speed diesel plant has been previously completed.<sup>1</sup> The experimental results based on pollutant data gathered from a medium speed diesel ship operating at sea is

---

<sup>1</sup> Markle, Stephen P., Development of Naval Diesel Engine Duty Cycles for Air Exhaust Emission Environmental Impact Analysis, Massachusetts Institute of Technology, 1994.

critically compared to these predictions.

## 1.2 Current Regulatory Stance

The Clean Air Act (as amended 1990), Section 213, requires the EPA to:

*"...Conduct a study of emissions from nonroad engines and nonroad vehicles...to determine if such emissions cause, or significantly contribute to, air pollution which may reasonably be anticipated to endanger public health and welfare."*

This study was completed in November of 1991 and led to the regulation of heavy duty nonroad diesels in June of 1994. The contribution of marine exhaust to ambient air quality was found to be significant, especially the contribution of nitrogen oxides (NO<sub>x</sub>).

The EPA estimates that there are 12 million marine engines in the United States.<sup>2</sup> This total number includes both spark ignition and diesel engines. Their studies indicate that 14% of the total non-road source of nitrogen oxides (NO<sub>x</sub>) can be attributed to marine diesels. The only greater contributors are land-based diesel engines rated at greater than fifty horsepower.<sup>3</sup> While the marine engine contribution may seem insignificant in comparison to the land-based emissions, the current legislative atmosphere requires aggressive regulation of all noticeable sources. Figure 1 refers.

Although it was noted in the EPA study that marine engine contributions for NO<sub>x</sub> and particulate matter were significant, these engines were not included in the June legislation. The reason for this delay lies partly in recognition by the EPA that existing test procedures for heavy duty off-road engines may be inadequate for ships.<sup>4</sup> Additionally, any regulatory scheme proposed by the EPA must first be reviewed for

---

<sup>2</sup> United States Environmental Protection Agency, "Air Pollution from Marine Engines to be Reduced", Environmental News, 31 October, 1994, p.1.

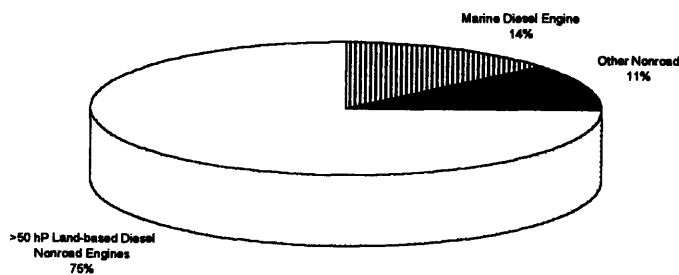
<sup>3</sup> Environmental Protection Agency Information Sheet, Reducing Pollution from Marine Engines: Information on the Marine Engine Rulemaking, released October 31, 1994, p.2.

<sup>4</sup> "Control of Air Pollution; Emissions of Oxides of nitrogen and Smoke From New Nonroad Compression-Ignition Engines at or Above 50 Horsepower", Federal Register, Vol.58, No. 93, p.28816.

conflict with U.S. Coast Guard directives which serve to ensure the safety of ships and seaways.

Some of the unique aspects of a ship's geometry pose additional difficulties in drafting regulations. The stack lengths on ships are typically longer than the exhaust lines on similar land based diesel engines. This additional length may allow continued reactions in the exhaust gases, possibly leading to the measurement of different pollutant levels at the exit of the stack than at the exhaust valve on the engine. The length of the stack on any particular ship is usually set by the internal arrangements and any pertinent criteria imposed by the ship's mission. This effect may be mitigated by the low residual time the exhaust gases need to travel the length of the stack and the isothermal nature of the stack system. In his 1994 thesis, Markle proved that for U.S. Navy medium speed diesels, there were no significant exhaust gas reactions in the stack.

**Figure 1: Breakdown of Nonroad Sources of NO<sub>x</sub><sup>5</sup>**



The ship's mission is a primary driver in the design of the hull form. The external shape of the hull affects the engine through the powering relationship. Hull friction and residual resistance counter the thrust created through the ship's propulsion system and

---

<sup>5</sup> EPA, Reducing Pollution from Marine Engines: Information on the Marine Engine Rulemaking, p.3.

determine the speed the vessel can attain. The same engine installed in two dissimilar hulls will be loaded at different engine torques and cylinder pressures in order to drive the two ships at the same speed. It is this consideration that is prompting most of the discussion within regulatory bodies regarding the best procedure for emissions testing. No consensus has been reached.

Based on the results of the emissions survey, and due to judicial action by the Sierra Club<sup>6</sup>, the EPA released a proposed marine engine emission legislation in early 1995. Under this plan, marine diesel engines under U.S. jurisdiction would be regulated in one of two manners as determined by the engine maximum power rating.

Smaller marine diesel engines (less than 50 hp or 37 kW) will be subjected to the following limits: NO<sub>x</sub> (9.2 g/kW-hr), HC (1.3 g/kW-hr), CO (11.4 g/kW-hr) and particulate matter (0.54 g/kW-hr)<sup>7</sup>. These smaller engines will be measured for compliance on the test stand and no further measurement will be required once installed on the vessel. The testing is to be conducted using ISO 8178, Part 1 procedures and duty cycles. The proposed standards are to be phased in during engine model years 1998 through 2006.

Engines rated at greater than 50 hp (37 kW) will be incorporated into existing regulations on land-based non-road engines of similar power ratings<sup>8</sup>. This ordinance, issued on 17 June, 1994, limits NO<sub>x</sub> to 9.2 g/kW-hr and particulate emissions to 0.54 g/kW-hr by 1999. Similar to the smaller engines, maximum pollutant limits will be phased in by model year.

---

<sup>6</sup> "Control of Air Pollution: Emissions Standards for New Gasoline Spark-Ignition and Diesel Compression-Ignition Marine Engines; Proposed Rules", Federal Register, Volume 59, No.216, 40 CFR Parts 89 and 91, November, 1994, p.55932.

<sup>7</sup> EPA, Reducing Pollution from Marine Engines: Information on the Marine Engine Rulemaking, p.3.

<sup>8</sup> Ibid, p. 2.

During conversations with EPA personnel<sup>9,10</sup>, they indicated that the proposed regulations were drafted to match as closely as possible the predicted international regulatory schemes. The U.S. regulators wish to avoid implementing an emissions control scheme which may be at odds with the proposed methods endorsed by international shipping organizations such as the International Maritime Organization, Marine Environmental Protection Committee (IMO, MPEC). This approach avoids penalizing ships calling at U.S. ports by not requiring them to meet different international and port state environmental standards.

Work on development of these international standards continues. Annex 6 to MARPOL, the document in which the program will be introduced, was due to be released in early 1995. The document has been delayed. A copy of the MPEC's proposal indicates that both regulatory sources will implement an approach to diesel engine exhaust compliance which requires bench test certification of an engine family. The engine parameters which designate an engine family have not been conclusively selected by either organization. Examples are engines which use the same type of fuel, method of air aspiration, number of cylinders, etc.<sup>11</sup> The intent is to group engine's with similar combustion and operating characteristics that should produce similar levels of pollution, thereby avoiding testing and certification of every engine model. Once the engine family has been certified, the EPA would require later testing of engines after a period of normal operation. In their plan, the targeted engine would be removed from a hull and relocated to a laboratory for testing. Where engine removal is not possible, the engines may need to be tested as installed.

The certification procedure referred to above is currently limited to steady state

---

<sup>9</sup> Interview with Ken Zerrefa, Environmental Protection Agency, National Vehicle and Fuel Emissions Laboratory, Ann Arbor Michigan, conducted via telephone on 10 January, 1995.

<sup>10</sup> Interview with Todd Sherwood, Environmental Protection Agency, National Vehicle and Fuel Emissions Laboratory, Ann Arbor, Michigan, conducted via telephone on 2 February, 1995.

<sup>11</sup> Federal Register, Vol 59, No. 216, p.55938.

engine operation. While the pollutant emission rate may be higher during transient operations, these maneuvers only contribute a small amount to total engine operating time<sup>12,13</sup>. Based on this conclusion reached independently by both the EPA and ICOMIA, duty cycle development should consider only steady state operations. The EPA, in the marine engine emission proposal, has asked for comments with regard to using a solely steady-state approach for certification testing of candidate diesel engines in order to provide a vehicle for dissenters to support their position.

Despite the similarities between the EPA and IMO proposals with regards to certification and monitoring, the IMO does not intend to adopt a single maximum NO<sub>x</sub> emission value for all diesel engines. Figure 2 is a graph of total NO<sub>x</sub> emissions as a function of rated engine speed. Rated speed is defined as the speed at which, according to the engine manufacturer, the rated power occurs. The total emission of NO<sub>x</sub> must be within the limits shown in Figure 2 when the engine is fueled with marine diesel oil and is operating at a relevant, pre-determined test cycle. This approach results in different emission limits for high and low speed engines and addresses the question of engine loading through the selection of an appropriate test cycle.

More stringent maximum single point NO<sub>x</sub> emission limits have been posed by the State of California. Due to the state's extremely poor ambient air quality, they have been required by law to address all pollution sources which are found to contribute to air quality deterioration, even if these sources are not regulated by the Federal government (refer to Section 209(e)(2)(A) of the amended Clean Air Act). New engine model NO<sub>x</sub> emissions will be required to meet a standard of 0.77 to 0.97 g/kW-hr<sup>14</sup>.

As of March, 1995, a State Implementation Plan (SIP) has not been approved for

---

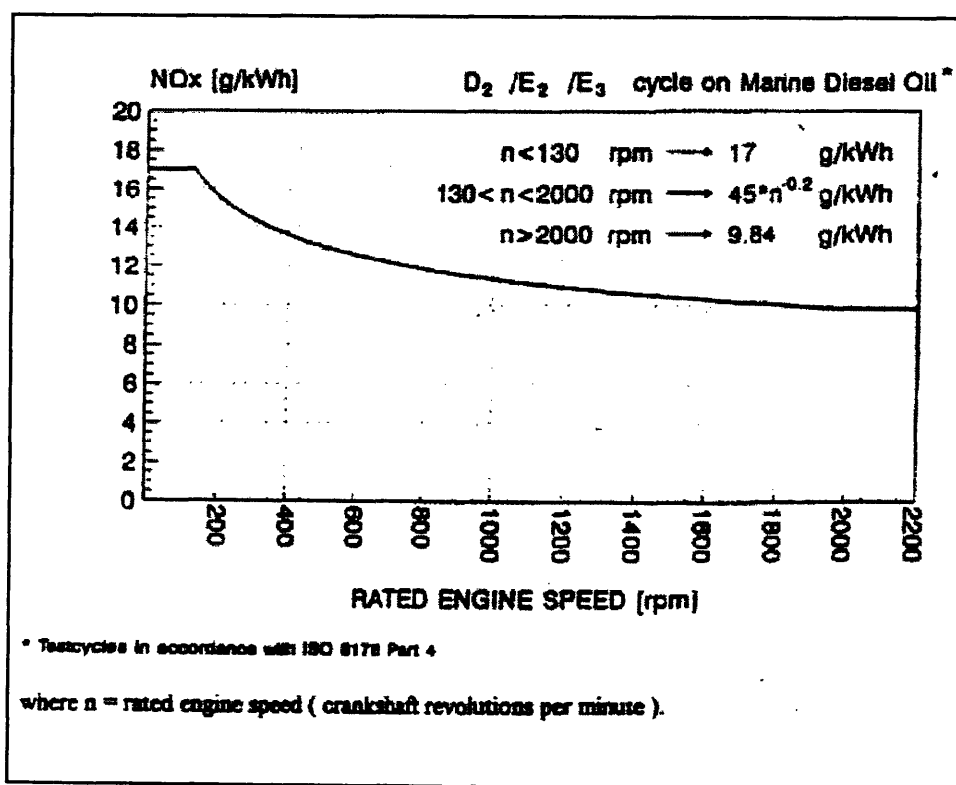
<sup>12</sup> Federal Register, Volume 58, No.93, p.28820.

<sup>13</sup> Morgan, Edward J., "Duty Cycle for Recreational Marine Engines", Society of Automotive Engineers, Paper no. 901596, 1990, p.10.

<sup>14</sup> English, R. E. and Swainson, D. J., "The Impact of Engine Emissions Legislation on Present and Future Royal Navy Ships", Presented at INEC 1994 Cost Effective Maritime Defense, 31 August - 2 September, 1994, p.3.

California. The California Federal Implementation Plan (CFIP) is a federally drafted plan which California must adopt until her own SIP is approved. The CFIP has adopted the CARB's approach to estimating marine emissions and added a fine/penalty system<sup>15</sup>. The implementation of the CFIP has been blocked due to economic concerns. The state recently released a SIP, which if approved by federal regulators would supersede the CFIP. The proposed regulatory scheme of the SIP is similar to the proposed EPA rulemaking.

**Figure 2: Maximum Allowable NO<sub>x</sub> Emissions for Marine Diesel Engines<sup>16</sup>**



<sup>15</sup> Markle, pp. 24-25.

<sup>16</sup> International Maritime Organization, "Draft Technical Guidelines for NO<sub>x</sub> Requirements under the New Annex for Prevention of Air Pollution", October 7, 1994 p.2.

For additional discussion of the CFIP and CARB studies, refer to Markle, 1994. Despite the separate plan and emission limits projected for the state of California, it is predicted that the majority of ships visiting U.S. ports will be regulated under the IMO/EPA proposal.

### **1.3 Motivation**

An approach to monitoring marine diesel engine emissions based on bench test results of sample engines prompts two discussions: 1) What is the correct duty cycle for testing of a marine vessel? Can all marine vessels be represented by the same duty cycle? and 2) How well does a controlled laboratory test capture the actual emissions of a ship's engine performing at sea?

A duty cycle is a sequence of engine operating modes each with defined speed, torque and time weighting factor. A survey of existing diesel engine duty cycles is presented in Markle, 1994. Emphasis will be placed on only one set of these duty cycles, those presented by the International Organization for Standardization (ISO) in its 1992 publication, "Reciprocal Internal Combustion (RIC) Engines - Exhaust Emission Measurement", ISO 8178-4. Thirteen duty cycles for various engine applications are listed in this document, four of which the EPA is considering for modeling of marine diesel engine operations<sup>17</sup>. The pertinent test cycles are provided in Table 1. The power figures are percentage values of the maximum rated power at the engine's rated speed.

ISO Duty Cycle C1 is primarily used to model off-road vehicles and industrial equipment with medium to high loads. The EPA has suggested this cycle to model marine auxiliary diesel engine operations. This definition would include all diesel generator sets. In recognition that C1 may not be the appropriate test cycle to model marine generator sets, which operate at a constant speed, cycle D2 has also been suggested.

ISO Duty Cycles E2 and E5 can be used to model marine diesel propulsion engines based on a propeller curve mode of operation as opposed to constant speed operations.

---

<sup>17</sup> Federal Register, Vol. 59, No. 216, p.55940.



Cycle E5 is developed from operational data gathered by Volvo and the Norwegian government and is appropriate for diesel engines in craft less than 24 meters long. It is intended to model craft which are not heavy loaded; therefore engines installed in tug boats and push boats less than 24 meters in length are excluded from using this test cycle. ISO Duty Cycle E3 is based on propeller curve mode of engine operation (as opposed to constant speed engine operation) and also represents heavy duty engines for ship propulsion with no limitations on the length of the ship. The final EPA legislation will dictate testing to be performed using one of these two cycles, selected on the basis of the arguments presented in response to the proposed rule-making. Neither may be appropriate for engine which drive controllable pitch propellers, which operate at low loads with a constant engine RPM.

The ISO 8178-4 RIC Duty Cycle E3 and E5 are derived from commercial vessel operation. Large commercial vessels (such as containerships, bulk carriers, etc.) are designed to sustain high usage rates at a relatively constant speed. They operate near the hull's maximum speed capability, with transient behavior only when entering and leaving port. Hence the emphasis in Duty Cycles E3 and E5 on high speed cruising near the rated power of the engine in the test cycles.

In general, naval ships spend less time at sea and operate with large variations in ship's speed. In recognition of this fact, a method for determining alternative diesel engine duty cycles for naval ships was developed and demonstrated for the LSD-41 Class Amphibious Vessel. The results of this analysis can be found in Markle. Markle used his duty cycle with appropriate test bench measured diesel engine emission maps to predict a single point annual pollutant emission amount. Using other common duty cycles and the same emission maps, a comparison could be accomplished and the appropriateness of applying commercial ship based duty cycles to naval vessels could be discussed.

#### **1.4 Thesis Outline**

The first section of this thesis applies the same methodology to a representative high speed main propulsion diesel engine in the United States Naval inventory. The

**Table 1: Sampling of ISO 8178-4 RIC Duty Cycles<sup>18</sup>**

Cycle Name	Mode Number	% Power	%Speed	Weight Factor
C1 % Torque not % Power	1	0	0	0.15
	2	50	60	0.10
	3	75	60	0.10
	4	100	60	0.10
	5	10	100	0.10
	6	50	100	0.15
	7	75	100	0.15
	8	100	100	0.15
	D2	1	10	100
	2	25	100	0.30
	3	50	100	0.30
	4	75	100	0.25
	5	100	100	0.05
	E3	1	25	63
	2	50	80	0.15
	3	75	91	0.5
	4	100	100	0.2
	E5	1	0	0
	2	25	83	0.32
	3	50	80	0.17
	4	75	91	0.13
	5	100	100	0.08

---

<sup>18</sup> ISO 8178, Part 4, Reciprocating Internal Combustion Engines- Exhaust Emission Measurement, Part 4: Test Cycles for Different Engine Applications, August, 1992, pp. 12-15.

selected ship class is the MCM-1 Mine Countermeasures Ship. Three of the thirteen ships in the class were visited and subsequently analyzed. Using data available both from recent bench testing of the Isotta Fraschini engine and from literature, an estimate of the annual pollutant emissions from a MCM-1 Class warship was computed. These results were critically compared to calculated emissions based on the ISO duty cycles.

As alluded to in the previous section, the proper method for estimating the emission tonnage which can be attributed to marine engines is still under debate. The bench testing of a representative engine at an appropriate duty cycle has been recommended by both the IMO and EPA. CARB's regulatory scheme uses emission estimates based on an assessment of traffic types and densities combined with an emission factor equating NO<sub>x</sub> levels to rated engine RPM. Other regulatory bodies employ different forms of emission factors, many of which are supported by little literature detailing the origins of the factors.

It is also strongly felt that many emission factors fail to account for common operating situations, such as mistuned engines, variations in emissions from engines of the same model, and variation in engine operating hours and maintenance levels. In particular, has been demonstrated that NO<sub>x</sub> levels are very sensitive to engine combustion chamber conditions<sup>19</sup>.

The second section of this thesis attempts to provide additional data to a growing database in order to resolve which emission estimation procedure best models actual levels measured from ships at sea. The instrumentation and collection of emission data from a LSD-41 ship operating at sea is discussed. The results are compared to estimates previously calculated<sup>20</sup> and proposed maximum emission limitations.

---

<sup>19</sup> Lloyd's Register Engineering Services, Marine Exhaust Emissions Research Programme: Steady State Operation, 1990, p.4.

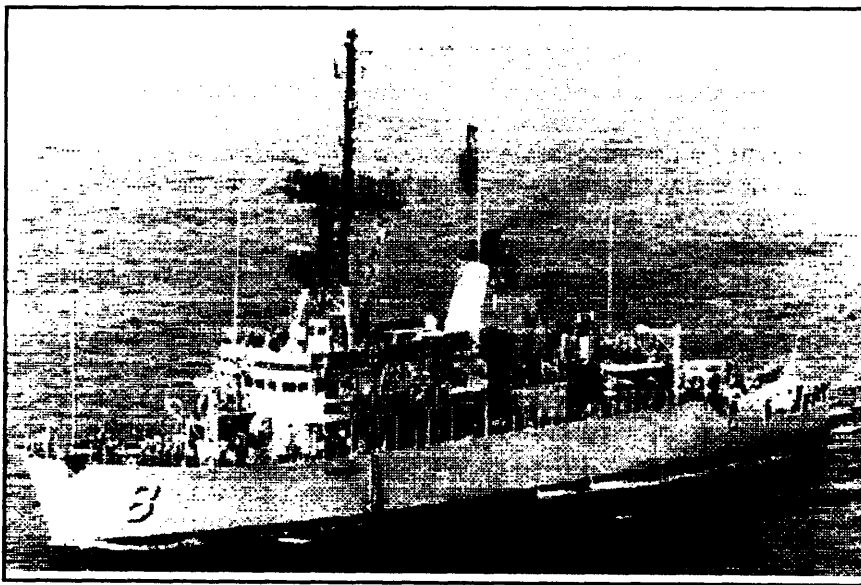
<sup>20</sup> Markle, 1994.

## **CHAPTER 2: MCM-1 Class Description**

### **2.1 Hull and Propulsion Plant Description**

The MCM-1 Mine Countermeasures Ship Class was designed to replace the older AGGRESSIVE and ACME classes of minesweepers (MSOs). The MCM-1 Class is designed to clear bottom and moored mines in coastal and offshore areas and is both larger and more capable than its predecessors. The wooden hull, with its glass reinforced plastic sheathing, is an unique characteristic of the ship. Figure 3 is a port bow view of the USS SCOUT (MCM-8) at sea. Figure 4 provides the class body plan, which simultaneously displays two half transverse elevations of the hull about a common vertical centerline. Principal dimensions are included as Table 2.

**Figure 3: USS SCOUT (MCM-8) Port Bow View<sup>21</sup>**

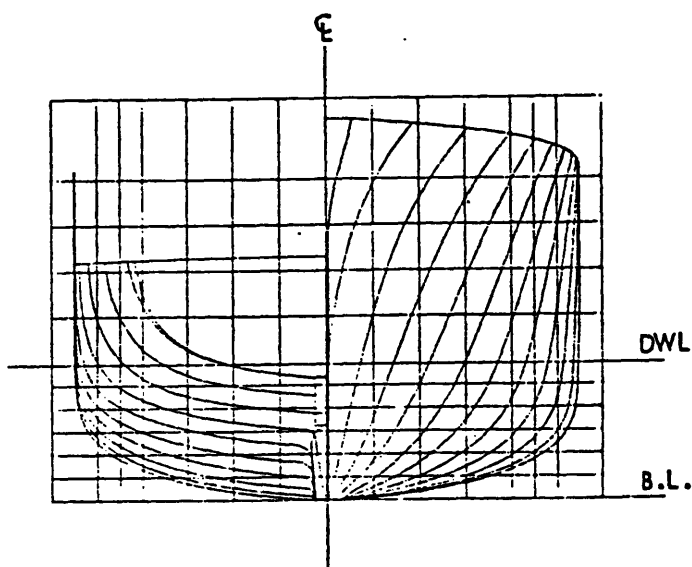


There are a total of fourteen ships in the MCM-1 Class. The first two hull numbers have a different propulsion plant, consisting of four Waukesha diesel engines and two propulsion shafts. These engines were found to be both noisy and maintenance intensive, and were replaced in the later hulls of the class.

---

<sup>21</sup> Ships and Aircraft of the United States Fleet, U.S. Naval Institute, Annapolis, Maryland, 1993, p.212.

**Figure 4: MCM-1 Class Body Plan<sup>22</sup>**



**Table 2: MCM-1 Class Hull Dimensions**

Design Displacement	1312 tons
Length Overall	224 ft
Length at Design Waterline	212 ft
Extreme Beam	39 ft
Design Draft	12.1 ft
Prismatic Coefficient ( $C_p$ )	0.575
Maximum Midship Section Coefficient ( $C_x$ )	0.842
Wetted Surface Area	
Water Plane Area Coefficient ( $C_{WP}$ )	0.755

The propulsion plant in the remainder of the ship class consists of four turbocharged Isotta Fraschini diesel engines rated at 600 horsepower with two smaller

---

<sup>22</sup> MCM Countermeasures Ship (MCM) Preliminary Design Hull Form Development Report (C), Naval Sea System Command report C-6136-78-31, February, 1979, p.41 (unclas).

(200 horsepower) direct current electric light load propulsion motors (LLPMs). Under normal steaming conditions, each shaft is driven by either one or two main propulsion diesel engines through a flexible coupling, a pneumatically operated tube type friction clutch and a single stage Philadelphia Gear reduction gear. The reduction gear ratio is given by equation (1).

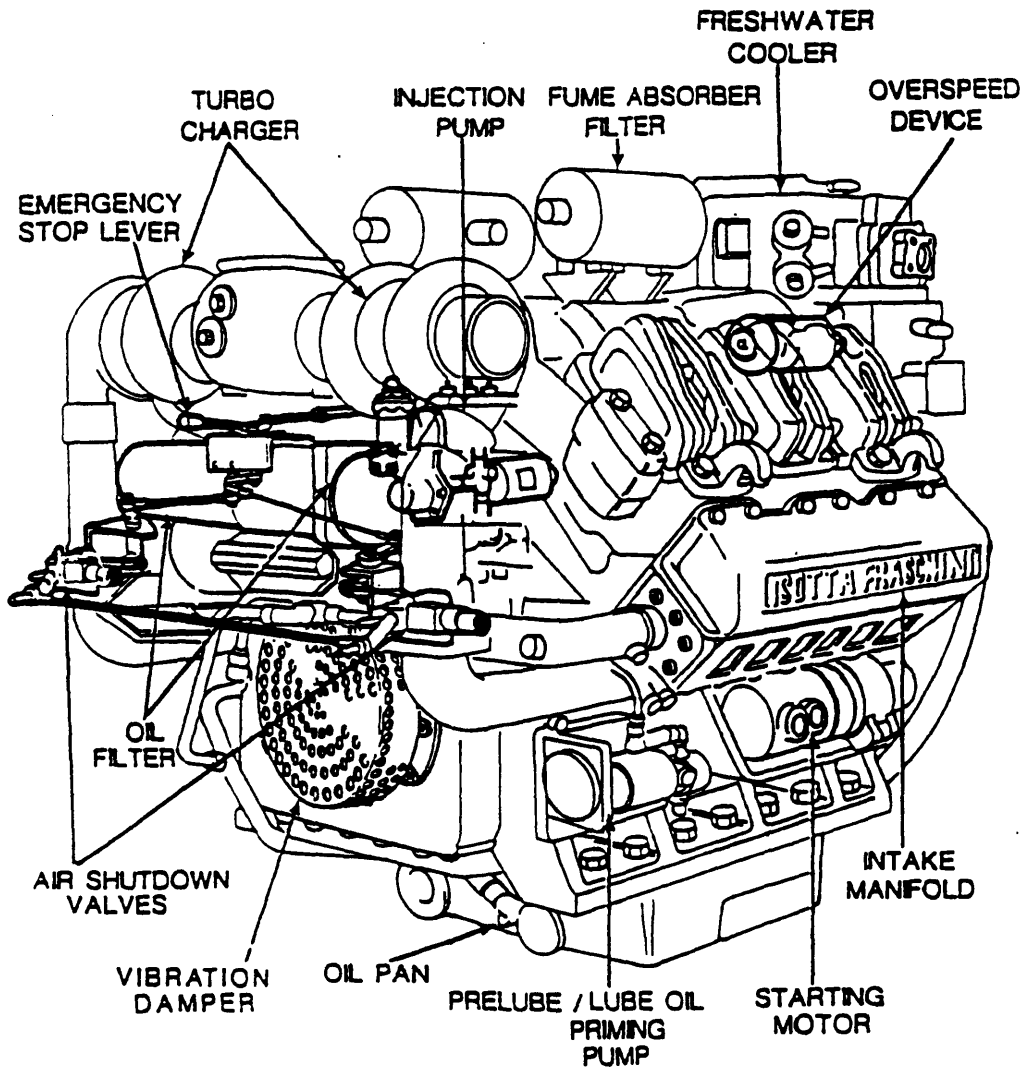
$$\Lambda = \frac{RPM_{DIESEL}}{RPM_{SHAFT}} = 10.64 \quad (1)$$

For light load conditions (less than eight knots), and at times when the ship wants to minimize waterborne noise, the reduction gears can be directly coupled to the light load electric motors. Power for these motors is provided by the ship's magnetic minesweeping gas turbine generator. Additionally, a 350 horsepower electrohydraulic bow thruster is installed. Three Isotta Fraschini diesels are also employed as the electrical generator prime movers. In this use, the engines run at a constant speed and are loaded lightly. Basic engine parameters are provided in Table 3. Figure 5 is a right, front view of the engine.

**Table 3: Isotta Fraschini Diesel Engine Parameters**

Model	Isotta Franchini ID 36 SS6 V-AM
Type	Non-Reversing
Cycle	Four Cycle, Turbocharged
Rated Load	600 hP
Rated RPM	1800 RPM
Bore and Stroke - inches	6.693" X 6.693"
Number of Cylinders	6
Piston Displacement	235 cubic inches
Engine RPM at Idle (Not Loaded)	795 RPM
Compression Ratio	13.2:1

Figure 5: Isotta Fraschini 36 556 V-AM, Right Front View<sup>23</sup>



<sup>23</sup> MCM-1 Class Ship's Information Book, Volume II, S9MCM-AC-SIB-020/MCM-3, Naval Sea Systems Command, Washington D.C., p.4-3.

Two inboard turning, controllable pitch propellers complete the drive train. As in any mechanical system, the connection of the various components is not accomplished without friction losses. The mechanical efficiency ( $\eta_{MECH}$ ) indicates the extent of these losses by comparing the shaft horsepower (SHP) measured at the propeller to the brake horsepower (BHP) measured at the engine output shaft. Equation (2) computes the mechanical efficiency of the drive train for the MCM-1 Class.

$$\eta_{MECH} = \frac{SHP}{BHP} = \frac{1175}{1200} = 0.979 \quad (2)$$

## 2.2 Ship Powering Curve

A ship's forward motion through the water is retarded by drag, which consists of frictional and residual drag forces. The amount of frictional drag is primarily determined by the wetted surface area of the hull. Air drag also is a part of the total frictional drag, but its contribution is usually quite small for naval combatant vessels. The residual drag forces consist of all forms of flow drag that are not residual. This includes wave-making and eddy forming resistance.

The amount of drag which a hull form will experience is determined early in the design process using numerical processes and model test results. This data is used to adequately size the propulsion plant so as to enable the hull to meet the desired sustained speed. After the ship is built, it is taken to sea and tested to determine the actual performance of the propulsion plant and hull under realistic operating conditions. The Propulsion Plant Standardization Trial is conducted on one ship of the class, and the class wide powering curves are constructed from its data.

The Standardization Trial for the MCM-1 Class was conducted on 14 June, 1991 aboard MCM-8, USS SCOUT. Table 4 contains a summary of the results of these trials. The testing was conducted at design displacement and draft; these conditions will be assumed throughout the analysis.

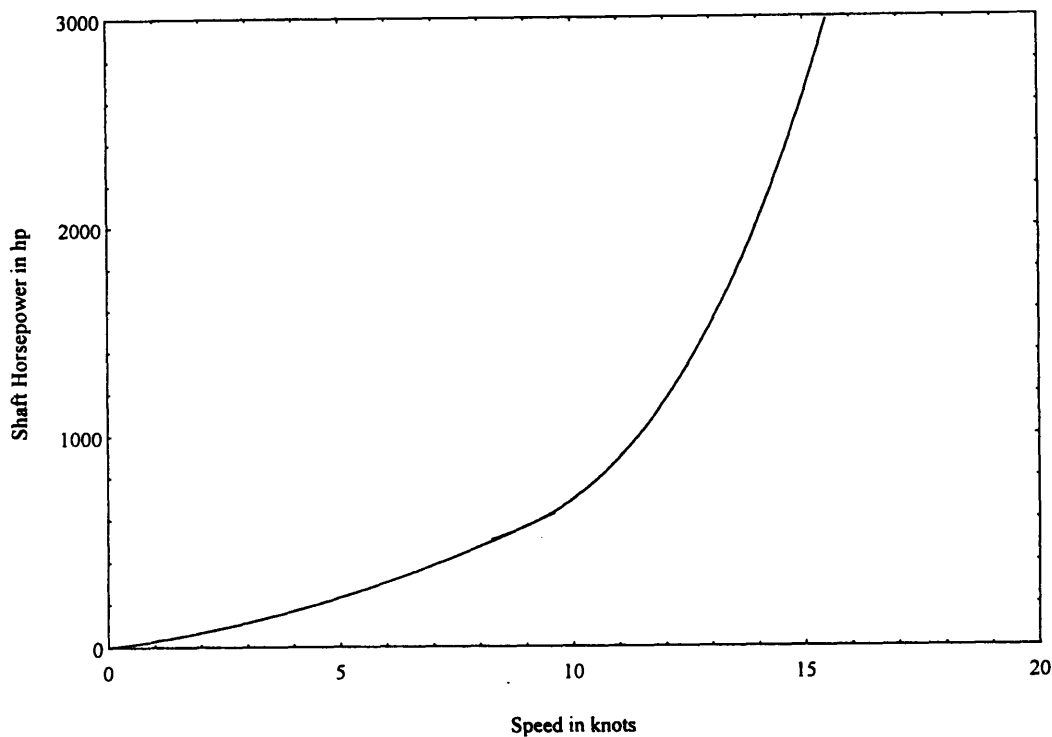


**Table 4: Standardization Trial Results<sup>24</sup>**

<b>Speed (knots)</b>	<b>Shaft RPM</b>	<b>Torque (lbf-ft)</b>	<b>Power (hP)</b>
11.8	139.8	42933.3	1143.3
12.7	150.75	500050	1435
13.4	160.8	57500	1760
14.3	175.2	67800	2260

The data in Table 4 suggests the relation between speed and power for the MCM-1 Class. Curve fitting the speed and shaft power data points provides the powering curve given in Figure 6.

**Figure 6: MCM-1 Class Powering Curve**



---

<sup>24</sup> Klitsch, Michael and Liu, Wayne, USS SCOUT (MCM-8) Results of Standardization, Locked and Trained Shaft Trials, Carderock Division, Naval Surface Warfare Center, CARDEROCKDIV-92/008, Bethesda, Maryland, May, 1992, pp.26.

The curve of Figure 6 represents two operating regimes. At speeds below 9 knots, which corresponds to a speed/length ratio less than 0.6, frictional resistance dominates. The power to overcome frictional resistance is a function of the ship's velocity squared and in this case is governed by equation (3).

At speeds greater than 9 knots, residual resistance dominates and the associated shaft horsepower per knot is a function of the ship's speed cubed. This relationship is represented by equation (4).

$$Power = 4.07 \cdot Speed^2 + 26.5 \cdot Speed \quad (3)$$

$$Power = 244.86 \cdot Speed - 40.029 \cdot Speed^2 + 2.449 \cdot Speed^3 \quad (4)$$

Equations (3) and (4) provide estimates of the required shaft horsepower necessary for the ship to maintain a certain speed. These equations apply for every ship of the class but gross errors can be introduced due to ship loading, hull fouling, machinery degradation or adverse weather conditions.

### 2.3 Standard Bell Order Table

For most ship classes, the Standardization Trials also provide the class wide relationship between shaft RPM, propeller pitch angle and ship's speed. The MCM-1 Class vessels, similar to many other naval ship classes with controllable pitch propellers, maintain a constant shaft RPM at low ship speeds, controlling the developed shaft thrust by adjusting the pitch on the propeller blades. Above a certain shaft power, the propeller pitch is held constant and the ship's speed is raised by increasing the shaft, and engine, RPM. The shaft power at which shaft RPM begins to increase at constant pitch (ramp-up) can be programmed through electronics, which monitor engine torque and usually include a feedback loop. An electronically predetermined throttle position corresponds to specific engine RPM and propeller pitch settings, which can be correlated to ship's speed using the

powering relationships developed from the Standardization Trials. The final result is a class wide standard bell order table which equates a specified bell order to an approximate ship's speed by indicating propeller pitch and shaft RPM.

Currently, class wide standard bell orders are not specified for use by the MCM Class ships. The primary reason lies with the relative newness the ship class. Unlike other feedback systems for the electronic controls which measure shaft torque directly or engine air box pressure, the MCM-1 controls receive feedback from secondary signals of propeller pitch and shaft RPM. The original ramp-up control points for MCM-3 through MCM-8 were found to cause an unacceptable engine acceleration rate when increasing the propeller pitch from 80% to 100%. To reduce this acceleration rate and account for changes in the LLPM motor controllers, the electronics were changed for MCM-9 through MCM-14. Plans are to retrofit the system changes to cover all ships of the class with Isotta Fraschini engines installed. Future plans also include adjusting the ramp-up controls feedback signal and relocating the measurement points to more accurate engine indicators such as the air box pressure or improved shaft torsion meters<sup>25</sup>.

The use of feedback signals originating from the propeller pitch and shaft RPM has also raised concerns of possible engine over-torquing if class standard bell orders are introduced prematurely<sup>26</sup>. Since the zero thrust pitch position for each ship of the class's propellers is not the same value, the engine load corresponding to a predetermined signal for maximum speed may call for an engine RPM and torque greater than the engine was designed for. Until improvements to the MCM-1 Class machinery plant control system are completed, each ship has been directed to conduct their own trials and develop appropriate bell order tables for their own use.

The bell order tables for three recently built MCM-1 Class ships (USS ARDENT

---

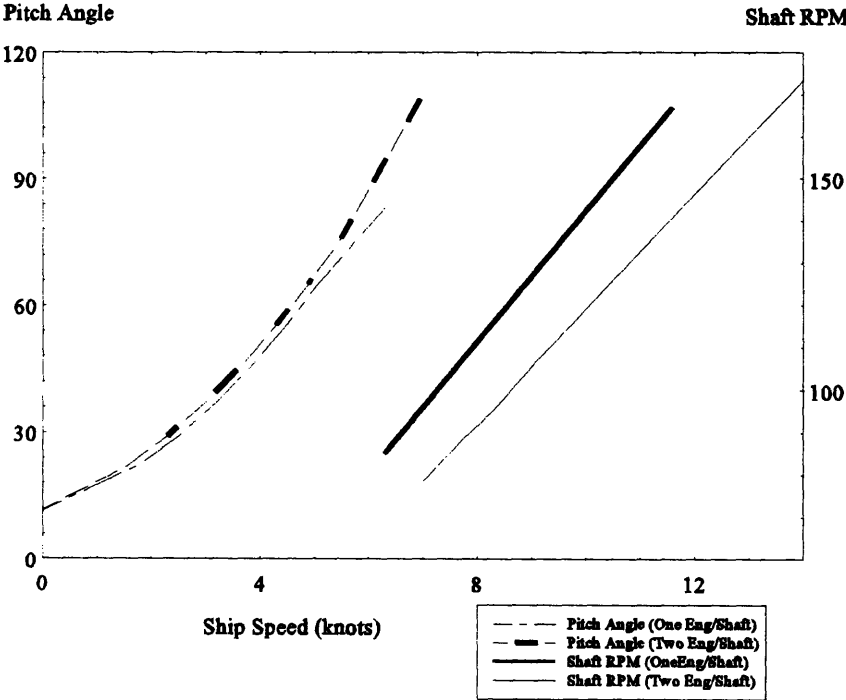
<sup>25</sup> Phone Conversation with Ray Conway, Naval Ship Systems Engineering Station (NAVSSSES), Philadelphia, PA dated 20 March, 1995.

<sup>26</sup> Phone Conversation with Gary Carlson, Code 260, Supervisor of Shipbuilding, Conversion and repair, USN (SUPSHIP) Sturgeon Bay, Sturgeon Bay, WI, on 21 Feb 1995.

MCM-12, USS GLADIATOR MCM-11 and USS WARRIOR MCM-13 ) were obtained and compared. The table of the USS GLADIATOR was selected as the best representation of propeller pitch/shaft RPM and ship's speed relationship for MCM-9 through MCM-14. It most closely matched the data points measured on MCM-8, USS SCOUT, during Standardization Trials. The relationship changes with the number of engines online. Figure 7 graphically depicts the linear relation between pitch/RPM and ship's speed when operating in the forward direction.

The different ramp-up points for four versus two engine operations is obvious from review of the Figure 7. This variation creates a different relationship between ship's speed and pitch/RPM as the total number of engines online is changed. For two engines online per shaft, equation (5) gives the ship speed equation for operation in the constant RPM region where speed is determined by propeller pitch. Equation (6) gives the ship speed as a function of RPM in the constant pitch region.

**Figure 7: Ship Speed Ahead versus Shaft RPM and Pitch Angle**



Equations 5 and 6:

*Two Engines Online Per Shaft:*

$$\text{Ship Speed} = 11.7 + 4.6 * \text{Speed} + 1.28 * \text{Speed}^2 \quad (5)$$

$$\text{Ship Speed} = 13.5 * \text{Speed} - 16.28 \quad (6)$$

Equations (7) and (8) provide the same relations when only one engine is online per shaft.

*One Engine Online Per Shaft:*

$$\text{Ship Speed} = 11.5 + 3.55 * \text{Speed} + 1.38 * \text{Speed}^2 \quad (7)$$

$$\text{Ship Speed} = 15.45 * \text{Speed} - 12.35 \quad (8)$$

The resulting Standard Bell Order Table is included as Table 5 and is used throughout this thesis when equating engine orders to ship's speed through the water. The astern direction bells have not been included as this thesis concentrates on steady state operation, and astern maneuvers are used only in transient operations.

In order to provide better control during tight maneuvering situations, such as station keeping during mine-hunting operations, a non-standard nomenclature is used for the bell orders. Only the MCM Class ships with the Isotta Fraschini main propulsion diesel engines (MPDE) have a control system designed to respond to bell orders ranging from one to ten. Increments as small as one tenth between these standard bells can be ordered, although the norm is to adjust only to the closest half bell.

**Table 5: Standard Bell Order Table**

<b>Bell Order</b>	<b>Speed (knots)</b>	<b>Engines/Shaft</b>	<b>Shaft RPM</b>	<b>Propeller Pitch</b>
All Stop	0	1 or 2	79	12
1.0	1.4	1	79	21
1.0	1.85	2	79	29
2.0	3.8	1	79	44
2.0	3.7	2	79	46
3.0	5.1	1	79	61
3.0	5	2	79	65
4.0	7	1	96	74
4.0	7	2	80	110
5.0	8.4	1	117	74
5.0	8.4	2	96	110
6.0	9.8	1	137	74
6.0	9.8	2	112	110
7.0	11	1	158	74
7.0	10.7	2	129	110
8.0	11.5	1	168	74
8.0	12.1	2	146	110
9.0	13.1	2	162	110
10.0	14	2	173	110

#### **2.4 MCM-1 Class Ship Operation**

Unlike other ships in the U.S. Navy inventory, the MCM-1 Class vessels assigned stateside do not deploy regularly. Rather, the crews of these ships are rotated to forward deployed ships of the class. The primary purpose of the stateside ships are to serve as

replacement vessels and to serve as training platforms for rotating crews. The nature of mine-hunting requires most training missions to be accomplished close to the shore, in waters of depths less than 1000 feet. In this role, the majority of the stateside MCM Class operations are conducted within fifty miles of land, in an operating area referred to as GOMEX, which stands for the Gulf of Mexico Operating Area. GOMEX is land bound, snugly situated with the Texas coastline to the north and west, Mexico to the South, and the Florida panhandle due east. The operating environment in GOMEX is greatly effected by close land masses.

Even when transiting to other continental U.S. ports for training or liberty, the short endurance of the ships precludes routing more than one day's travel distance from land. Based on these established patterns, it is reasonable to assume that all MCM-1 Class operations occur within 100 nautical miles of land. This proximity to land increases the possibility that the exhaust emissions of the MCM-1 Class contribute to the pollution problems of coastal areas.

In the GOMEX operating area, the ship conducts a wide variety of crew training. This may include engineering plant casualty, damage control, man overboard and ship handling drills. These evolutions are conducted at a myriad of speeds and engine alignments. Minehunting training can be either mine sweeping, which is conducted at a singular slow speed or minehunting, which is conducted at slow speeds or at idle with many speed changes. Infrequently, the Main Propulsion Diesel Engines (MPDEs) are disengaged and the shafts are propelled by the LLPMS while conducting slow speed, quiet mine hunting operations. In contrast, the ship operators prefer to transit at high speed, which for this ship class approaches twelve to fourteen knots. Despite the relative newness of the class, these operating patterns appear to be well developed.

The method by which the MCM-1 Class operating profile was established was based on a similar analysis conducted on the LSD-41 Class Amphibious Ships by Markle in 1994. A variety of operational logs were gathered, including the ship's Deck Log and Engineering Log. The Deck Log is a legal document which records all significant events in the course of a day. Underway, it is also the document used to record the time and

magnitude of all speed and course changes. The speed changes are given in terms of a bell order, which equates to a predetermined propeller pitch angle, shaft RPM and ordered speed. A sample Deck Log sheet is provided in Appendix A.

The Engineering Log records all pertinent information regarding plant status and evolutions in the engineering spaces. The most important entries in this log for analyzing the ship's operating profile is the starting, clutching, declutching and stopping of MPDEs. A sample Engineering Log is also provided in Appendix A.

In order to develop an appropriate operating profile for the MCM-1 Class, copies of these two logs from three of the fourteen ships were collected. The three ships selected had recently completed similar operations, including GOMEX training operations, transit to Panama City, Florida for advanced combat systems training, and additional transit to support crew's liberty. Included in the six months reviewed are unequal portions in which all engines were out of commission due to repair work. Table 6 presents a summary of the operating time evaluated.

**Table 6 : MCM-1 Class Ship Data Summary (time in hours)**

	USS ARDENT	USS GLADIATOR	USS WARRIOR
Hull Number	MCM-12	MCM-11	MCM-13
Time Period (1994)	1 May - 31 Oct	1 May - 31 Oct	1 May - 31 Oct
Data Points	4926	6330	3757
Time Covered	211318	221760	161640
Time Secured	191321	187603	139130
Time Running	19997	34157	22510
Time Declutched (Cool Down)	623	1830	965
Time @ Idle	2974	2155	1022
Time @ Power	16400	30172	20523

Table 6 implies that the MPDEs are operated a low percentage of the total time



analyzed. This is a reflection of the low availability of the MCM-1 Class equipment (including the Isotta Fraschini Engines) and the modest range of the vessels. Most GOMEX maneuvers are conducted in a single day, with a return to port at the conclusion. It is not anticipated that these patterns will change significantly as the class matures.

The method of forming the operating profile closely follows that used by Markle. The Engineering Logs and Deck Logs were used to determine the amount of time each engine was online at specific speed and power combinations. Figure 8 recreates a flow chart of the logic used in the analysis. The composite operating profile for all three ships is included in Table 7.

**Table 7: MCM-1 Class Composite Operating Profile Time Factors**

<b>Ship Speed (knots)</b>	<b>One Engine/Shaft</b>	<b>Two Engines/Shaft</b>	<b>Total</b>
Idle	*	*	0.114
1	0.002	0.002	0.004
2	0.005	0.008	0.013
3	0.002	0.006	0.008
4	0.01	0.011	0.012
5	0.019	0.012	0.031
6	0.009	0.004	0.013
7	0.034	0.017	0.051
8	0.05	0.01	0.060
9	0.018	0.002	0.020
10	0.053	0.283	0.336
11	0.089	0.075	0.164
12	0.04	0.005	0.045
13		0.094	0.094
14		0.023	0.023

**Figure 8: Operating Profile Analysis Flow Chart**

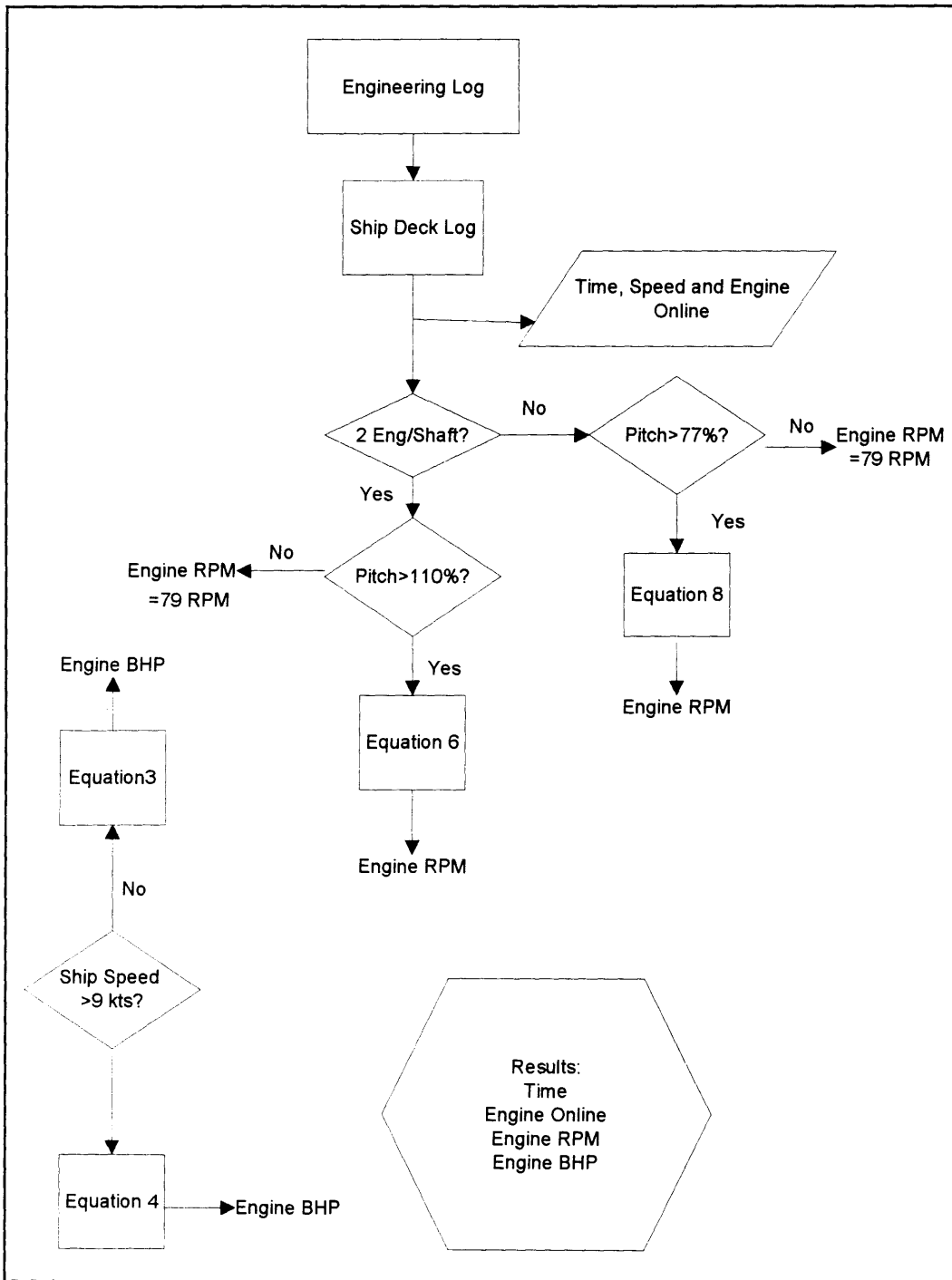


Figure 9 presents the data of Table 7 in an easily viewed format. Review of the figure implies that the MCM-1 Class ships operate primarily at the higher speed ranges and at idle. The idle time factor also includes time the engines spent at cool-down and declutched. Although there was no requirement for a significant warm-up period prior to clutching in the Isotta Franchini engines, standard operating procedure does include a five minute cool-down period. The idle time factor was defined to include all intervals in which the engine was operated declutched for cool-down or drills and intervals in which the ship was making no headway, but the engines were online. The difference in engine load for these conditions is insignificant. There is also a significant spike at ten knots, a preferred speed for transit operations.

**Figure 9: MCM-1 Class Composite Operating Profile**

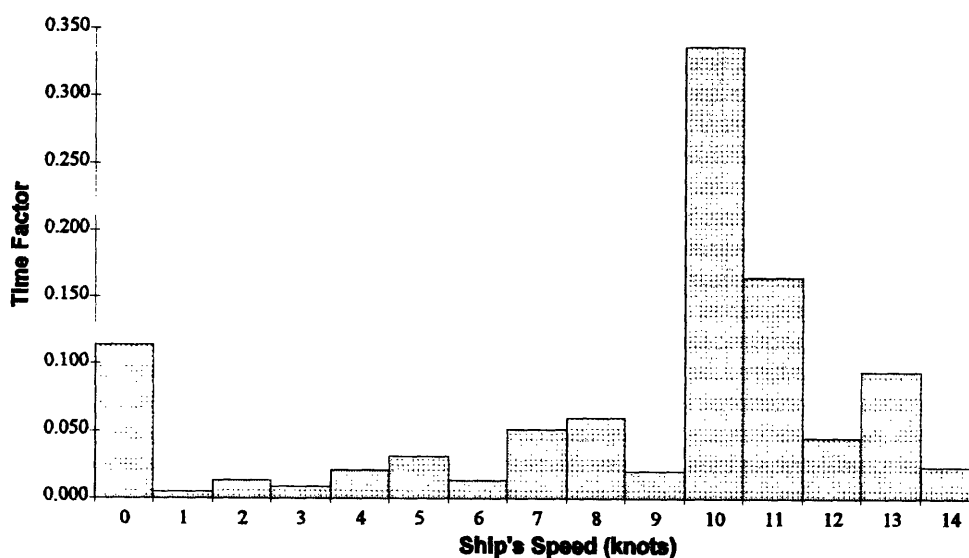


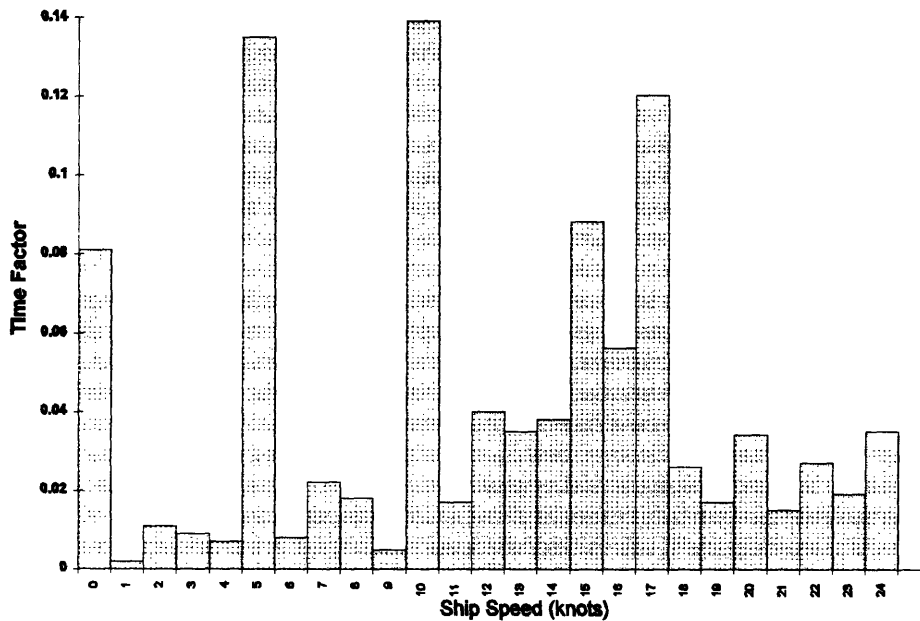
Figure 9 can be contrasted to Figure 10<sup>27</sup>, which is recreated from Markle. Figure 10 is the composite operating profile for the LSD-41 Class Amphibious Vessel. The ships are powered by Colt-Pielstick PC2.5-V16 engines, a medium speed diesel. The profile for operation of the amphibious ship indicates greater time factors for the slower speeds of five and ten knots and a spread centering on seventeen knots to

---

<sup>27</sup> Markle, p.83.

represent transit operations. The notable difference in the operating profile between the two ship classes implies that the ship's mission has a significant impact on the duty cycle and should be the primary factor on which the duty cycle is based.

**Figure 10: LSD-41 Class Composite Speed Operating Profile**



**Figure 11: Composite Operating Profile Cumulative Time Factor Comparison**

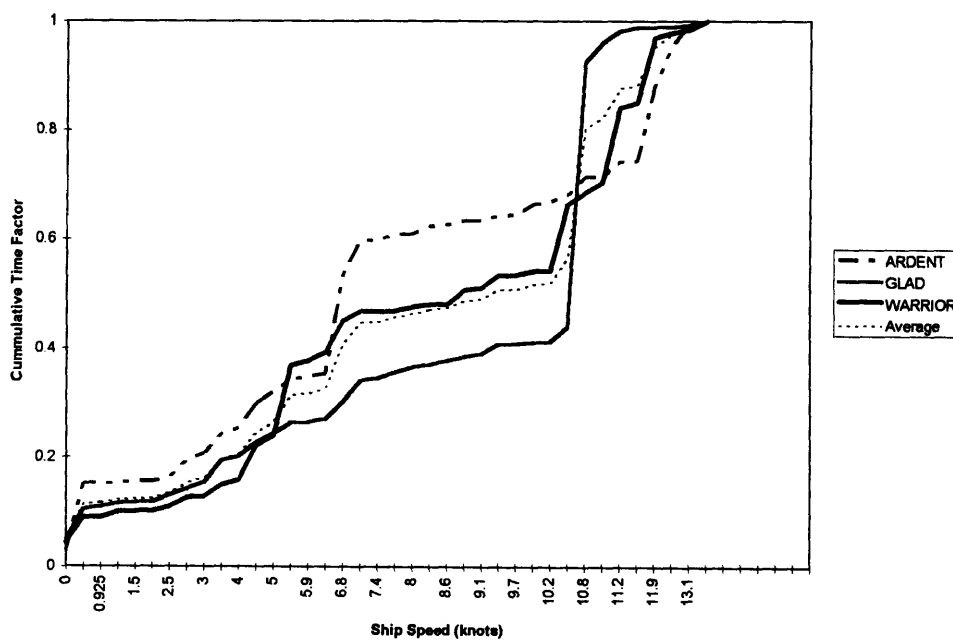


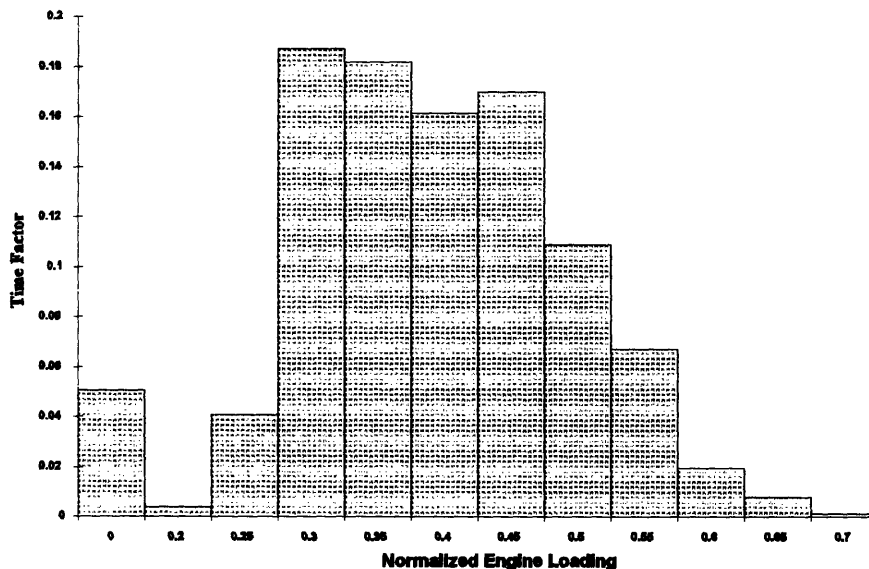
Figure 11 demonstrates the variation in how each of the MCM-1 Class ships considered in the analysis were actually operated. The variation at low speeds is minimal, with significant deviations beginning at a speed of approximately six knots. This variation reflects the influence of operator preference in developing a class wide operating profile. The large spike at approximately 7.5 knots for the USS GLADIATOR was created when the ship was tasked with additional transit operations beyond those assigned to the other two ships analyzed. This was an isolated event which had little impact on the class wide operating profile.

Operating logs from one ship were analyzed to predict the SSDG operating profile. Table 8 provides a summary and Figure 12 presents the data graphically. The operation of the MCM-1 Class SSDGs is concentrated around the 50 percent load point. This pattern matches that observed in Markle for the SSDGs aboard the LSD-41 Class Amphibious Ships. The parallel results for ship classes with radically different missions can be attributed to U.S. Navy standard operating procedures. Navy ships are required to keep additional generators online over what is required by the electrical load in the event of a casualty. If one generator is lost, there must be sufficient capacity remaining to continue to provide the vessel adequate electrical power for operation. This requirement is common for all naval ships, and explains the similar SSDG operating profile for both the MCM-1 and LSD-41 Classes.

**Table 8: SSDG Engine Operating Profile Time Factors**

<b>Engine Speed (% of Rated)</b>	<b>Engine Load (% of Rated)</b>	<b>Time Factor</b>
1.0	0.0	0.05
1.0	0.25	0.04
1.0	0.30	0.19
1.0	0.35	0.18
1.0	0.40	0.16
1.0	0.45	0.17
1.0	0.50	0.11
1.0	0.55	0.07
1.0	0.60	0.02
1.0	0.65	0.01

**Figure 12: MCM-1 Class SSDG Operating Profile**



## **Chapter 3: MCM-1 Class Duty Cycle and Comparison**

### **3.1 MCM-1 Class Duty Cycles**

In Chapter Three of his 1994 thesis, Markle describes the development of duty cycles for generic application to land based diesel powered systems. In all of these systems, the useful power out of the diesel engine is countered by static and rolling friction forces. The relationship between these forces, vehicle size (weight) and engine loading results in a fairly constant percent plant output for a given vehicle speed. This consistency, despite differences in manufacturers or vehicle size, allows accurate modeling of most engines' operations using generic duty cycles.

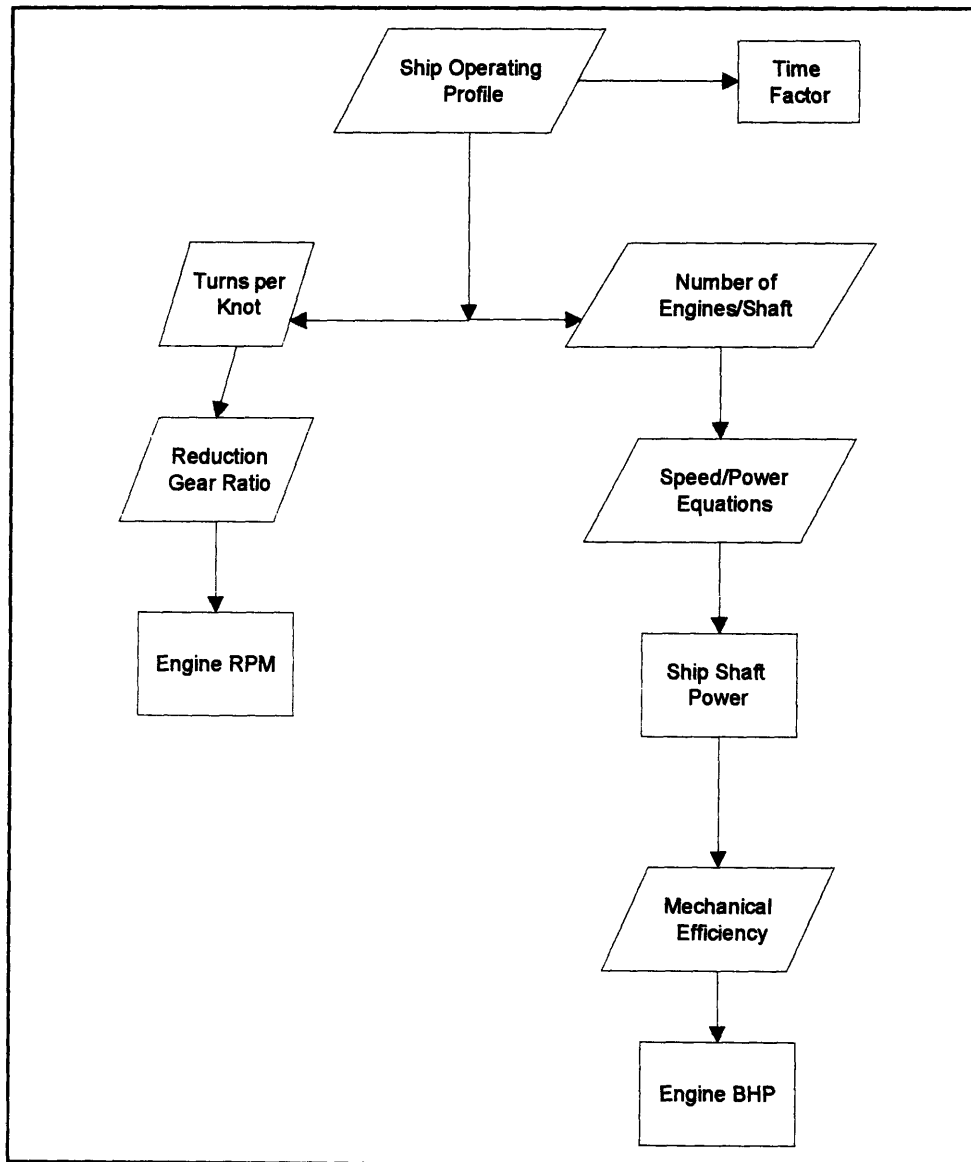
Markle then compares engine horsepower normalized by vehicle weight (or ship displacement) against weight or displacement in an effort to reveal the wide variability in ship displacements and power requirements. For naval ships, this variability has two causes: 1) the engines are sized to provide a "burst speed" capability, and 2) the underwater hull form of ships with similar displacements can be radically different, creating varying powering relationships for each hull. A generic duty cycle for marine vessels would be inadequate for modeling all ships because of this unique resistance relationship. The class specific duty cycle must be generated based on the time factor, engine power and speeds of the class wide speed operating profile.

Previously, the operating profile for the MCM-1 Class was developed from a review of actual ship operating logs. The composite operating profile can be combined with ship specific propulsion train and powering information as indicated in Figure 13 to determine the MCM-1 Class duty cycle. The MPDE duty cycle presented in Table 9 was created using the method charted in Figure 13 and by combining engine speed and power ranges about the most heavily weighted operating points. As the ship can be operated with either one or two engines per shaft, the duty cycle contains representations of both alignments.

The MCM-1 Class duty cycle contains significantly more data points than duty cycles created to model commercial ship operations which were introduced in Chapter

One. The additional data points are necessary to model the wider variation in operating speeds experienced by a Naval ship. The MCM-1 Class operating profile displays a bias toward high speed transit versus slower speed maneuvers. Despite this pattern, sufficient slow speed operating points must be included in a duty cycle to project an image of all types of maneuvers.

**Figure 13: Naval Ship Duty Cycle Analysis Flow Chart<sup>20</sup>**



<sup>20</sup> Markle, p.81.



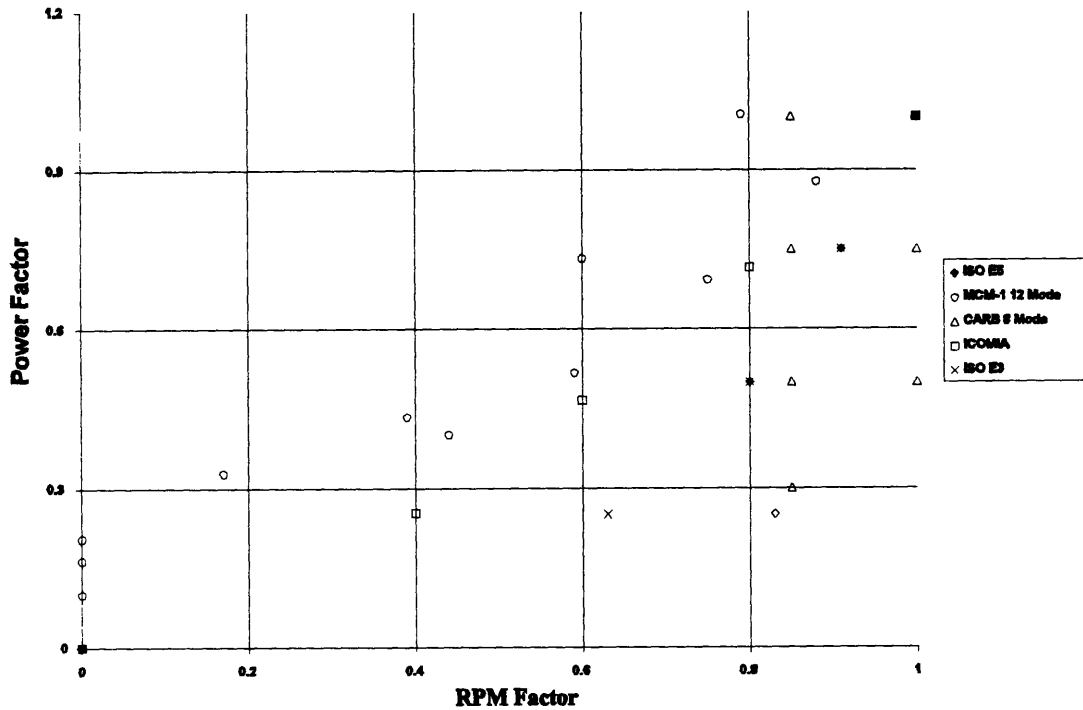
**Table 9: MCM-1 Class MPDE Duty Cycle**

<b>Mode</b>	<b>Ship Speed (knots)</b>	<b>Engines/Shaft</b>	<b>Engine Speed (% of Rated)</b>	<b>Engine Power (% of Rated)</b>	<b>Time Factor</b>
1	0	0	0.44172	0	0.123
2	3.7	2	0.44712	0.100	0.0129
3	3.8	1	0.44172	0.205	0.0310
4	7	1	0.536	0.328	0.0466
5	7	2	0.44172	0.164	0.0184
6	8.4	1	0.657	0.434	0.0537
7	9.8	1	0.778	0.732	0.0728
8	10.3	2	0.685	0.401	0.305
9	11.3	2	0.772	0.518	0.081
10	11.6	1	0.881	1.00	0.130
11	12.6	2	0.863	0.693	0.101
12	13.9	2	0.935	0.877	0.025

The MCM-1 MPDE Class duty cycle is plotted along with the other duty cycles introduced in Chapter One as functions of engine RPM and load (Figure 14). The MCM-1 Class duty cycle has a greater number of operating points and more closely matches a representative plot of a propeller curve for controllable pitch propellers.

The duty cycle for the SSDG prime movers is developed in a similar fashion. The typical underway electrical load is 360 kW, usually split between two generators for safety through redundancy. The rated electrical load for one generator is 375 kW, which accounts for losses incurred converting mechanical energy to electrical energy. At anchor, the load on each generator decreases to approximately 25% of the rated engine power. The MCM-1 Class SSDG duty cycle is presented in Table 10.

**Figure 14: Duty Cycle Engine Speed and Power Points**



**Table 10: MCM-1 Class SSDG Duty Cycle**

Mode	Engine Speed (% of Rated)	Engine Load (% of Rated)	Time Factor
1	1.0	0	0.07
2	1.0	0.3	0.21
3	1.0	0.35	0.21
4	1.0	0.4	0.19
5	1.0	0.45	0.20
6	1.0	0.5	0.12

This duty cycle varies slightly from that derived for the LSD-41 Class Amphibious Ship, with the MCM-1 Class SSDGs tending to be more lightly loaded. It is also similar enough to the proposed ISO 8178 D2 duty cycle that this testing procedure could be used with minor adjustments.

### 3.2 MPDE Duty Cycle Comparisons

In order to validate the MCM-1 Class duty cycles, estimates of the composite duty cycle pollutant levels were compared to estimates developed from the composite operating profile. As of April 1995, an emissions map for the Isotta Fraschini diesel engine has not been released to the public. Therefore, an emissions contour plot for a similar sized engine was used to compare the accuracy of the duty cycles in modeling actual MCM-1 Class operations. The contour plots were developed from bench testing of a Pielstick PA4-200-VGA diesel engine. The rated speed of the engine was slightly less than the Isotta Fraschini (1500 versus 1800 RPM) and the rated power per cylinder was slightly greater (123 bhp/cylinder versus 100 bhp/cylinder). Copies of the gaseous emissions contour plots were found in the August, 1992 edition of *Motor Ship*<sup>28</sup> and are plotted as a function of engine speed and power. The curves are normalized to rated power and speed and recreated in Appendix B. They are also reproduced as Figures 15 to 17. Equations (9) and (10) were used in normalizing the speed and engine power.

$$Power\ Fraction = \frac{Power\ Point}{Power\ Rated} \quad (9)$$

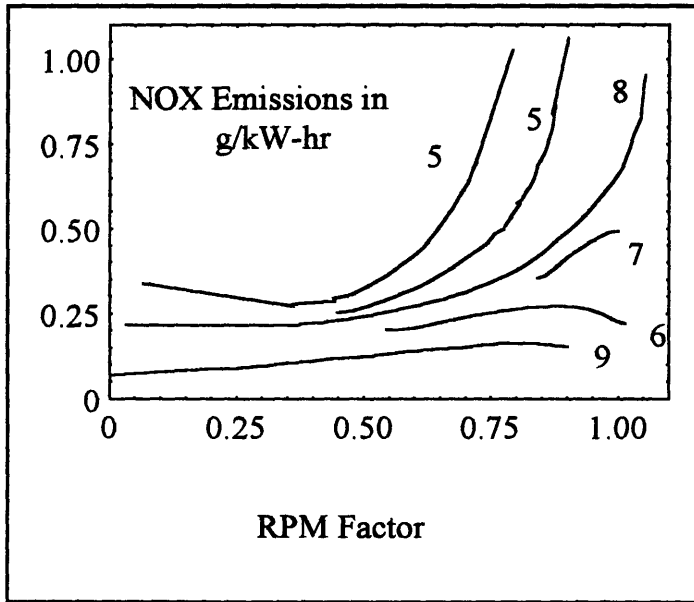
$$RPM\ Factor = \frac{RPM\ Point - RPM\ Idle}{RPM\ Rated - RPM\ Idle} \quad (10)$$

The MCM-1 Class operating profile power fraction and RPM factor data points for both one and two engines per shaft alignments are superimposed on each of the three normalized contour plots. Additionally, the operating points for each duty cycle are also imposed. These plots are contained in Appendix C. The pollutant values for each plotted operating point (power fraction and RPM factor) are linearly interpolated, multiplied by the respective time factor and summed to establish the emission amount in g/bhp-hr for the class operating profile and each duty cycle.

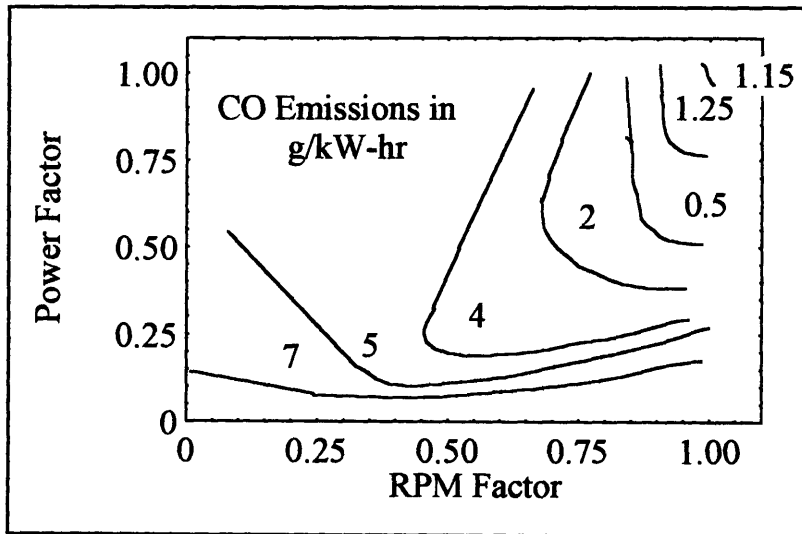
---

<sup>28</sup> "Designers Anticipate Engine Emission Controls", *Motor Ship*, August, 1992, p.28.

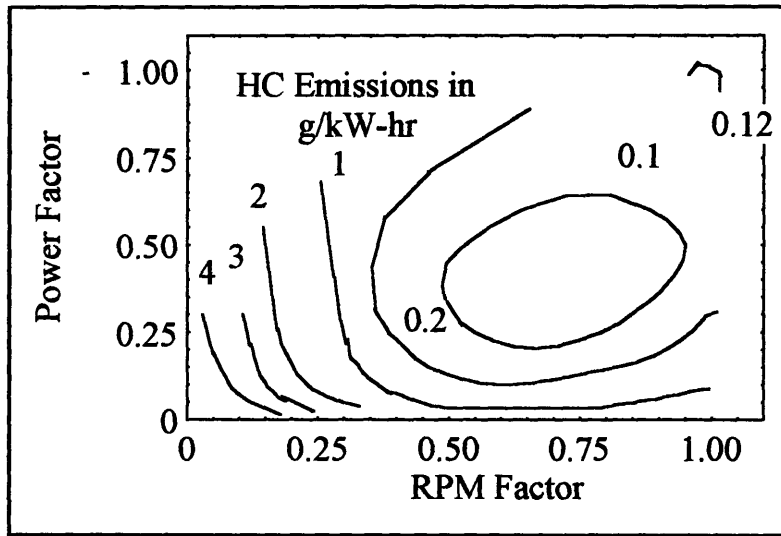
**Figure 15: Pielstick PA4-200-VGA NO<sub>x</sub> Emission Contour Map (g/kW-hr)**



**Figure 16: Pielstick PA4-200-VGA CO Emission Contour Map (g/kW-hr)**



**Figure 17: Pielstick PA4-200-VGA Gaseous HC Emission Contour Map (g/kW-hr)**



The calculation of the weighted average emission sum is performed using equation (11)<sup>29</sup>. The power and time factor for each operating point are determined by the duty cycle, and the pollutant value is picked off the emission contour maps at each operating point. These results are summarized in Table 11 and all supporting calculations are included as Appendix C.

$$\text{Weighted Average} = \frac{\sum^{i=n} \text{Pollutant Value}_i \text{ (g/hr)} \cdot w_i}{\sum^{i=n} \text{BHP}_i \cdot w_i} \quad (11)$$

where  $n$  is the number of operating points in the duty cycle and  $w$  is the weighted time factor.

---

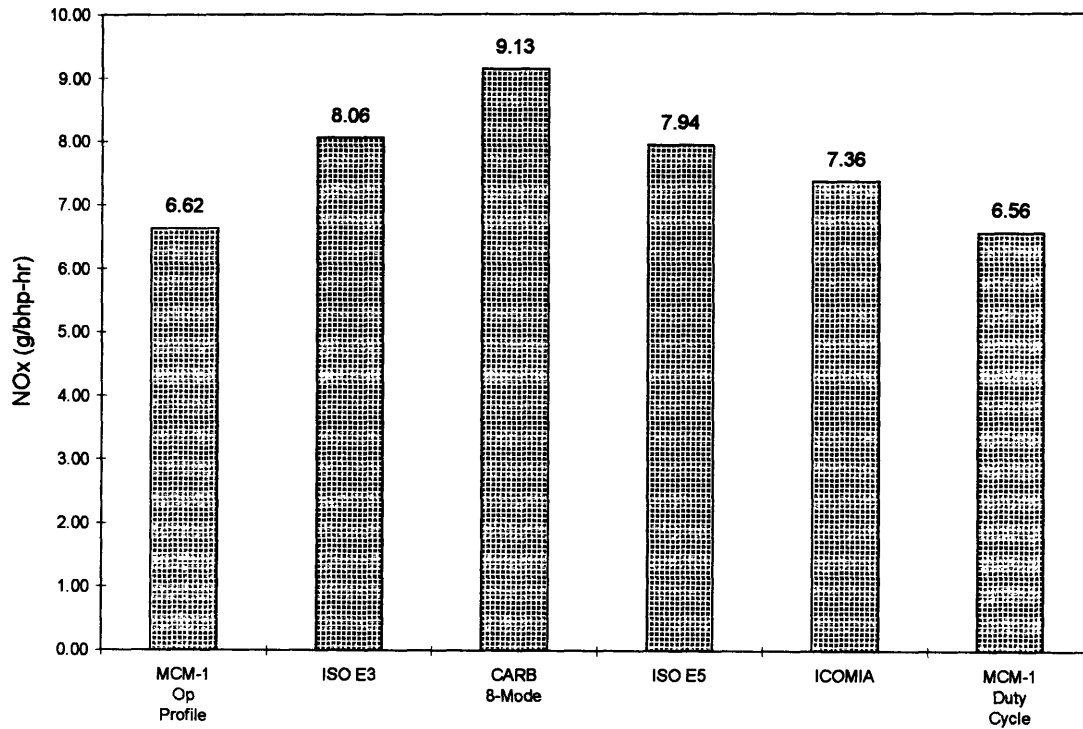
<sup>29</sup> ISO 8178, Part 2, Reciprocating Internal Combustion Engines- At site Measurement of Gaseous and Particulate Exhaust Emissions, October, 1992, p.13.

**Table 11: MPDE Duty Cycle Emission Prediction Summary**

	<b>NO<sub>x</sub> (g/bhp-hr)</b>	<b>CO (g/bhp-hr)</b>	<b>HC (g/bhp-hr)</b>
MCM-1 Operating Profile	6.62	3.63	0.46
MCM-1 Duty Cycle	6.56	4.14	0.43
ISO E3 Duty Cycle	8.06	1.68	0.14
ISO E5 Duty Cycle	7.94	2.49	0.14
ICOMIA 36-88 Duty Cycle	7.36	2.96	0.16
CARB 8-Mode Duty Cycle	9.13	1.30	0.14

The values in Table 11 are not emissions estimates for the Isotta Fraschini engine. The emission contour plots onto which the propeller curve and duty cycles were superimposed were not developed from Isotta Fraschini tests, but for a similar high speed diesel engine (Pielstick PA4-200-VGA). As the actual contour plots for the Isotta Fraschini engine are not available, the Colt-Pielstick engine's emissions are substituted so that the accuracy of each duty cycle as a model could be determined from comparison to the cumulative, weighted emissions of the operating profile described in Chapter Two. To ease the comparison, the predicted emissions from each duty cycle and the operating profile are plotted simultaneously in Figures 18 through 20.

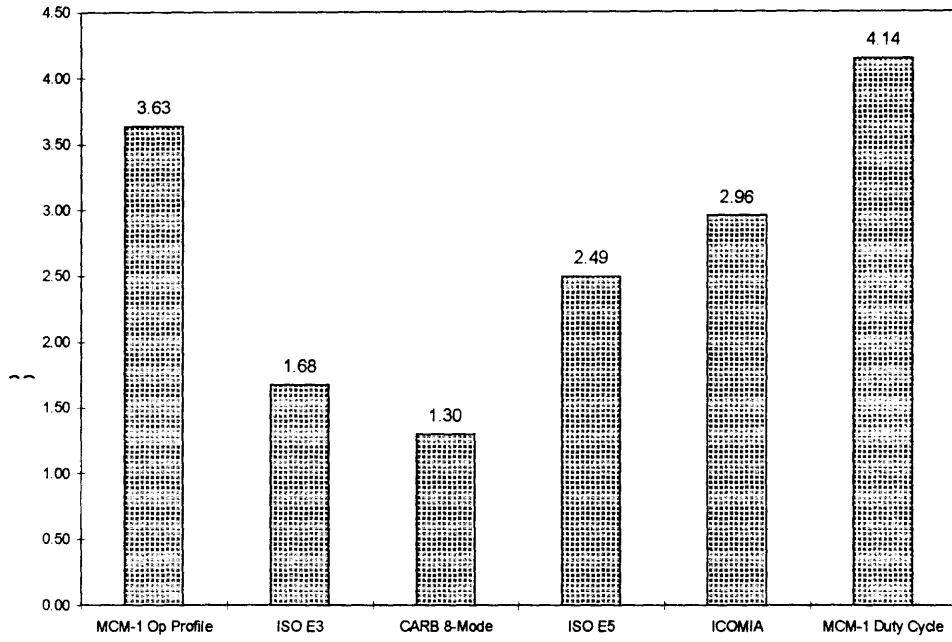
**Figure 18: MPDE NO<sub>x</sub> Prediction Comparison (g/bhp-hr)**



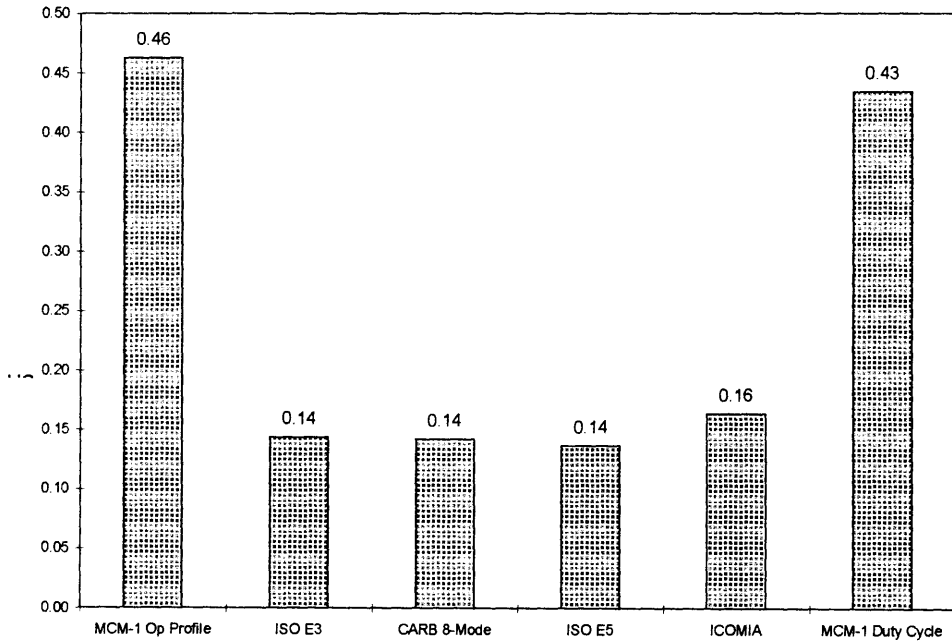
Note: *MCM-1 Duty Cycle* is the cycle introduced in Table 9.

*MCM-1 Op Profile* is the cycle introduced in Table 7 of Chapter Two.

**Figure 19: MPDE CO Prediction Comparison (g/bhp-hr)**



**Figure 20: MPDE Gaseous HC Prediction Comparison (g/bhp-hr)**





The emissions from the MCM-1 MPDE Duty Cycle provide the closest comparison to those predicted from overlaying the MCM-1 Class MPDE operating profile onto the Pielstick PA4-200-VGA emissions contour maps. The NO<sub>x</sub> figure is within two percent, the HC prediction is just over five percent higher and the CO figure has the greatest error at 15 percent. None of the generic ISO duty cycles could match this performance in modeling of the actual ship operations.

### 3.3 SSDG Duty Cycle Comparisons

This same procedure for predicting and comparing the specific emissions of appropriate duty cycles against the predicted emissions of the engine operating profile was repeated for the Isotta Fraschini engine used as a generator prime mover. Summary emissions for the duty cycles appears in Table 12.

**Table 12: SSDG Duty Cycle Emission Prediction Summary**

	<b>NO<sub>x</sub> (g/bhp-hr)</b>	<b>CO (g/bhp-hr)</b>	<b>HC (g/bhp-hr)</b>
SSDG Operating Points	9.02	2.52	0.22
SSDG Duty Cycle	8.86	2.64	0.22
ISO C1	8.38	3.04	0.23
ISO D2	9.76	2.33	0.23

Figures 21 through 23 indicate the ISO C1 and D2 Duty Cycles are inappropriate for modeling of the MCM-1 Class SSDG. The C1 Duty Cycle has been recommended by the EPA for use in qualification testing of marine auxiliary diesel engines<sup>30</sup>. It is not a constant speed cycle. The ISO D2 Duty Cycle has also been considered by the EPA for use in testing engines destined for marine auxiliary uses and it is a constant speed test cycle. The emission predictions of neither duty cycle adequately matched those of the operating profile.

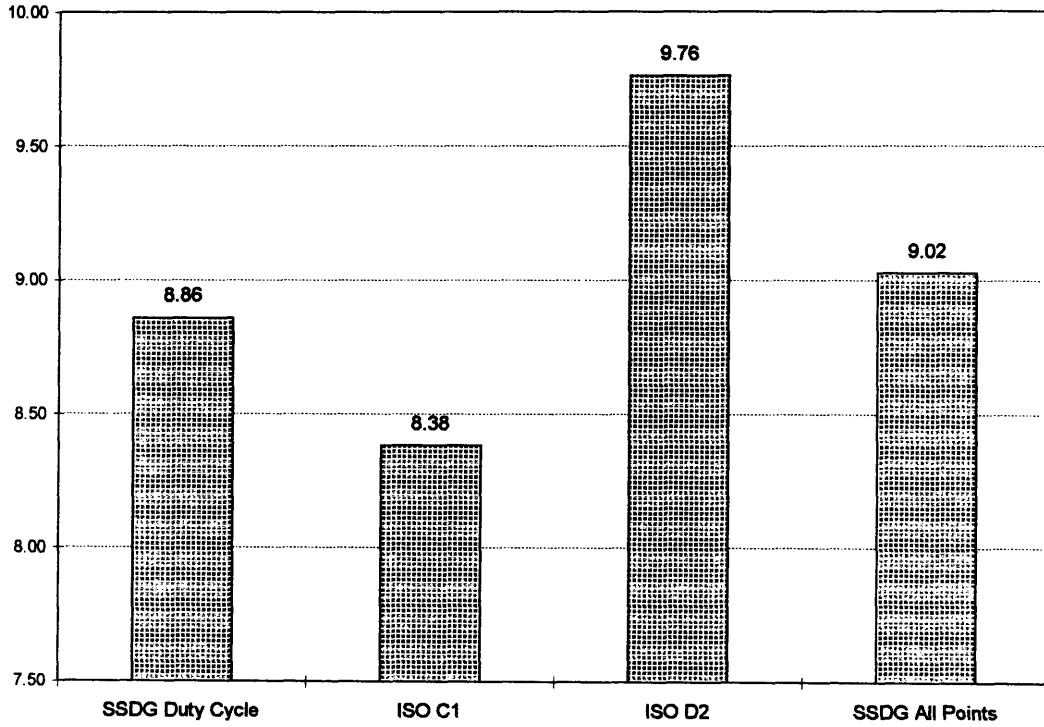
The best approximation to the SSDG operating profile (Table 8) is provided by the

---

<sup>30</sup> Fed Reg, Vol. 59, p.55940.

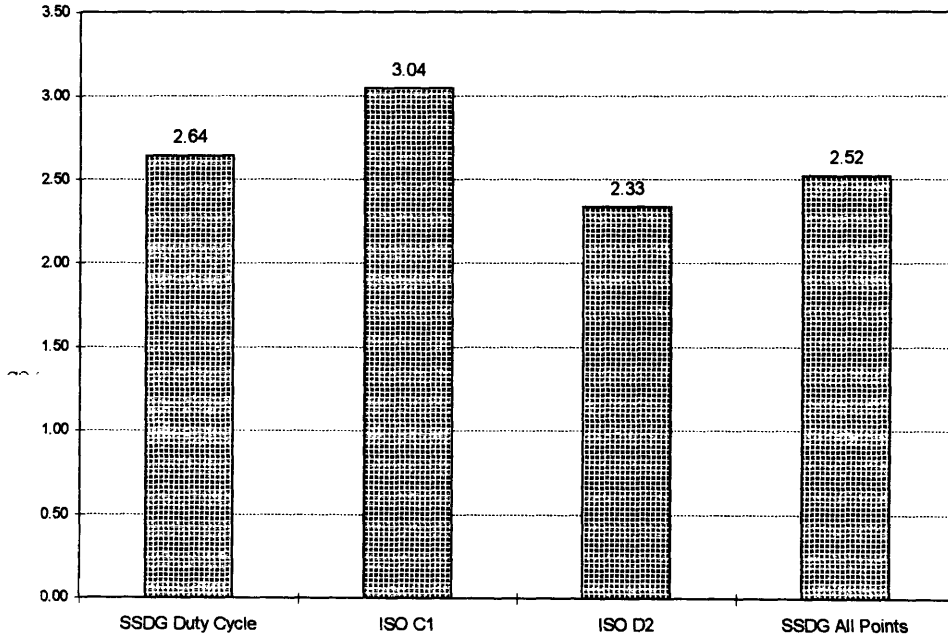
SSDG Duty Cycle (Table 10). The maximum errors compared to the emission predictions of the MCM-1 Class SSDG operating profile are as follows: NO<sub>x</sub>, 2%; CO, 5%; and gaseous HC, 1%.

**Figure 21: SSDG NO<sub>x</sub> Prediction Comparison (g/bhp-hr)**

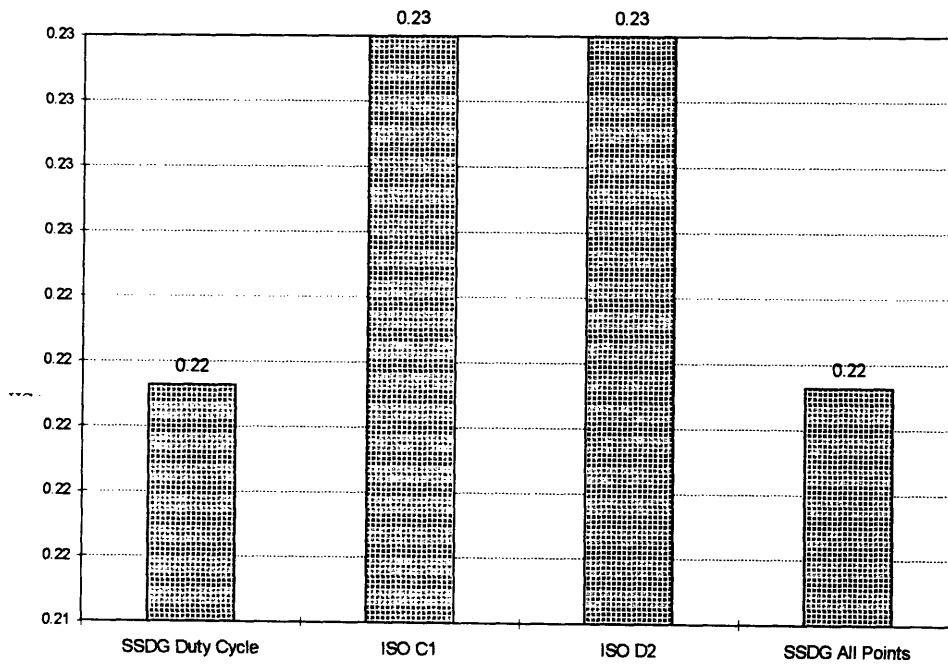


Note: *SSDG All Points* is the cycle introduced in Table 8 of Chapter Two.

**Figure 22: SSDG CO Prediction Comparison (g/bhp-hr)**



**Figure 23: SSDG Gaseous HC Prediction Comparison (g/bhp-hr)**



### **3.4 Duty Cycle Conclusions**

The predicted emissions of the MCM-1 Class MPDE operating profile were best estimated by the MCM-1 MPDE Duty Cycle. While this duty cycle best matched the operating profile data, the amount of effort necessary to develop the MPDE duty cycle from review of operating logs was extensive. The LSD-41 results, using the same analysis method, also found that the generic duty cycles were not accurate enough when modeling naval ship operations<sup>31</sup>. Based on the both the LSD-41 and MCM-1 Class analyses, it appears that the additional effort to create a class specific duty cycle is warranted.

A procedure for Naval engine emission certification was proposed in Markle. Candidate diesel engines would first pass the Navy Endurance Test, demonstrating the engine's ruggedness and ability to withstand demanding naval applications. Emissions measured during this 1000 hour test would be monitored for compliance with existing regulations. Once certified, the engine becomes available for use in a new or existing naval ship design.

During the ship design process, the candidate engine may be selected. The ship's resistance can be predicted from aspects of the hull form and a preliminary powering curve produced. Using the procedure of Figure 13, the resistance data based on the hull form can be transformed to appropriate engine speed and load data points. The time weighting of these data points is based on the ship's operating profile, if known, or predicted from the operating profile of naval ship classes with the same primary mission. The candidate diesel engine is re-tested using the recently developed duty cycle and emissions are measured following ISO guidelines. The resulting emissions profile can then be included in the Program Manager's Environmental Impact Statement and compared to federal and local regulations to determine compliance.

As of April 1995, two U.S. Navy ship classes which are powered by diesel engines have been studied and a rough operating profile developed. The LSD-41 Class Amphibious Ship, powered by medium speed diesel engines, was successfully modeled by

---

<sup>31</sup> Markle, p.101.

Markle. The MCM-1 Class Mine Countermeasures Ship, with her high speed diesel engines, was modeled in this report. Both efforts used the same time-intensive procedure of extracting operating information from ship's logs. The determination of a Naval ship class's operating profile could be improved through the use of automatic data collection systems which would tap existing control and reporting electronics. Data gathered in this fashion would be accurate, non-intrusive and available in a format easy to compile. The operating profiles could be compared to existing the generic duty cycles required by regulation to determine if these cycles are adequate for modeling of a naval ship class performing the same mission. If the generic test cycle is found inadequate (an anticipated result), the Navy should propose an appropriate test cycle derived from the operating profile for application to all ship classes with the same mission.

## **Chapter 4: Experimental Set-Up**

### **4.1 Discussion of Previous Work**

Environmental and maritime agencies which are being pressed to regulate marine diesel exhaust emissions are disadvantaged by a lack of an adequate data base in this area. The effects of the sea environment, the impact of unique exhaust system features due to the ship's geometry, and appropriate engine test cycles are still topics for discussion and further research.

Lloyd's Register Engineering Services, a division of Lloyd's Register of Shipping, has undertaken an effort to quantify marine pollution contributions in both transient and steady-state operations through seaborne testing<sup>31</sup>. It was their goal to evaluate exhaust emissions from a broad cross-section of the world fleet in order to provide a realistic assessment of the nature and magnitude of the marine pollution contributions. The data base would then be used by regulatory bodies to develop realistic emissions factors and encourage discussions regarding the best methods of emission reduction and control. Their steady-state testing was conducted on numerous commercial ships during normal operations. The hulls were selected to cover a broad range of ship types and included such vastly different vessels as bulk carriers, ferries, tankers and tugs. Emissions of NO<sub>x</sub>, SO<sub>2</sub>, CO, CO<sub>2</sub>, O<sub>2</sub> and hydrocarbons were collected for five operating conditions covering a range from idling to full power. No particulate emissions were gathered due to the expense associated with the collection procedure. In addition to exhaust measurements from the top of the stack, Lloyd's also collected the ship's heading, speed, shaft load and local weather conditions. Their method of measuring, while not intrusive with regard to the ship's mission, required great amounts of space in the area of the stacks since full sized NDIR (Non Dispersive Infra Red) analyzers were used.

Their trends for CO matched the literature<sup>32,33</sup>. The CO mass specific values were

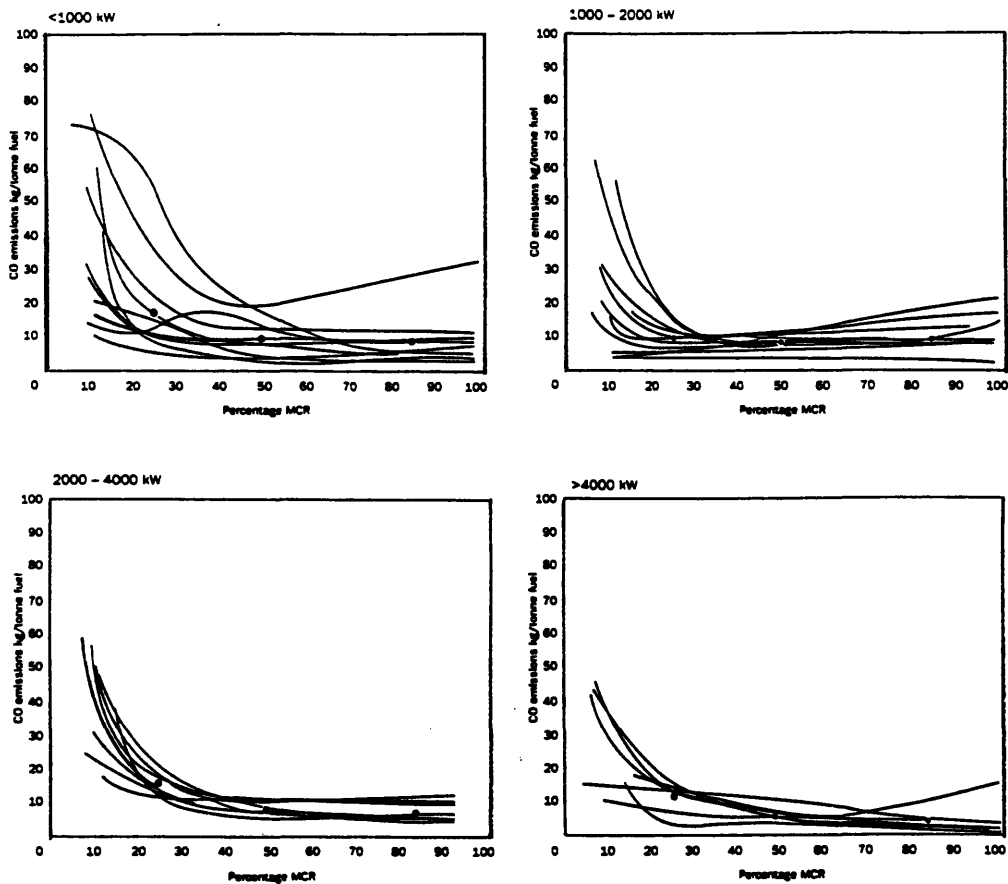
---

<sup>31</sup> Lloyd's Register Engineering Services, pg. 1-8.

<sup>32</sup> Heywood, p 592.

uniformly low for all engines except at light load conditions. Figure 24 presents the measured CO in units of Kg/tonne of fuel plotted against engine load reported as percentage of the maximum continuous rating (MCR). The plots are for numerous types of ships propelled by diesel engines and are grouped by the range of the engine's maximum MCR rating. The mean mass specific emissions for 25%, 50% and 85% MCR are indicated by dots in the graphs.

**Figure 24: Lloyd's Register CO Results<sup>34</sup>**

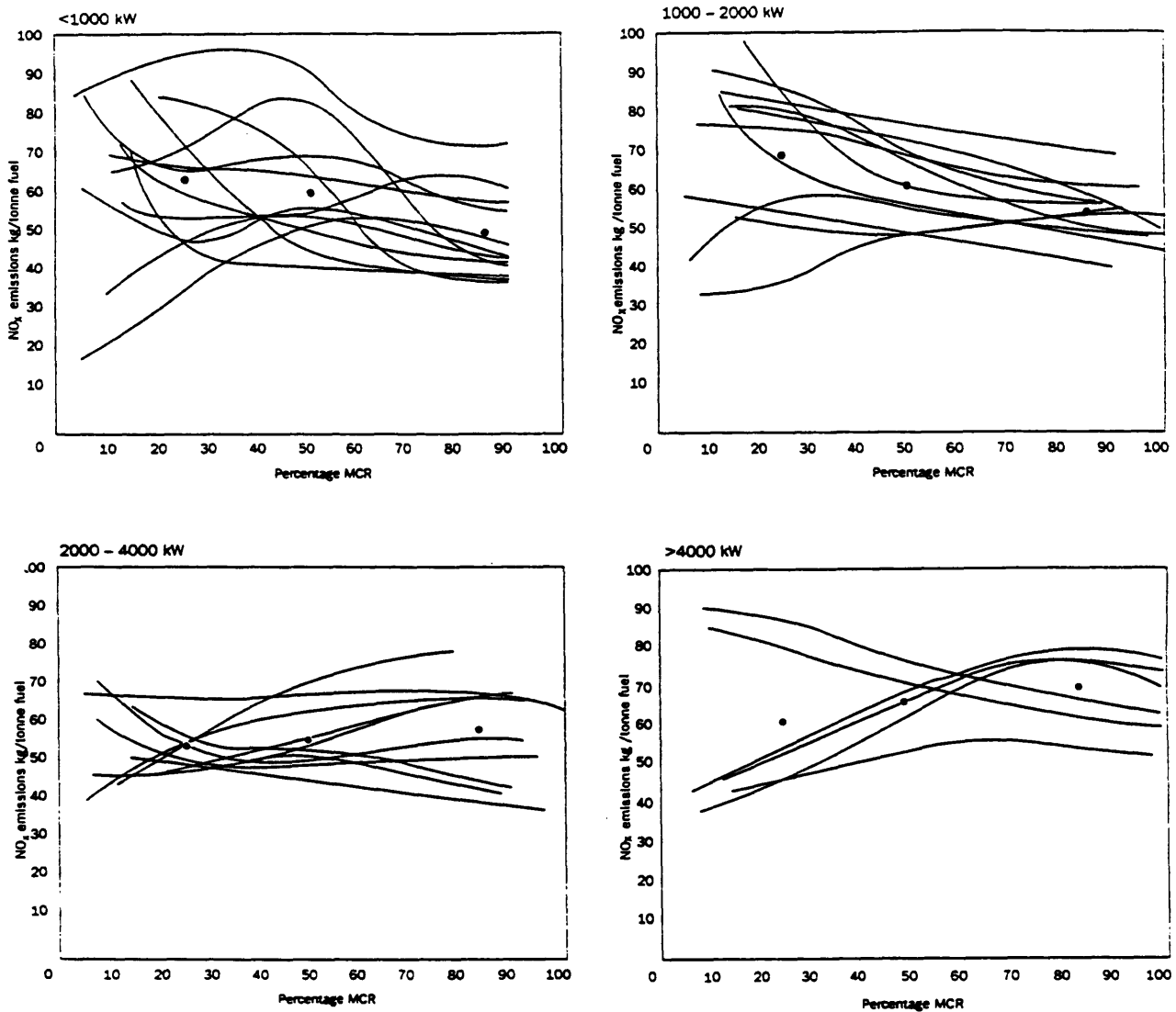


<sup>33</sup> Ghoniem, Ahmed F., Fundamentals, Modeling and Computations in Combustion, MIT Class Notes, March, 1994.

<sup>34</sup> Lloyd's Register Engineering Services, p. 13.

The mass specific emissions of NO<sub>x</sub> did not behave in a well defined trend. As can be seen in Figure 25, there was no discernable pattern of NO<sub>x</sub> concentration as a function of load. The most important factors associated with NO<sub>x</sub> appeared to be the engine design and engine age, as opposed to mode of operation or engine load<sup>35</sup>.

**Figure 25: Lloyd's Register NO<sub>x</sub> Results<sup>36</sup>**



<sup>35</sup> Ibid., p.12.

<sup>36</sup> Ibid., p.15.



Shipboard testing of marine diesels continues in the U.S. under the sponsorship of the U.S. Coast Guard. This is in response to the need to develop a methodology for accurately determining engine emissions in order to assess the impact of emissions reduction techniques. Their approach slightly differs from that of Lloyd's Register. The Coast Guard used a duty cycle based on a survey of PT boat operators and measured the emissions with more flexible and smaller portable emission analyzers (the small size of the Coast Guard platforms precluded use of multiple, firmly installed analysis equipment). The use of the portable analyzers allowed the emissions to be measured at the exit of the turbocharger vice at the exit of the stack, precluding the need for heated sampling lines.

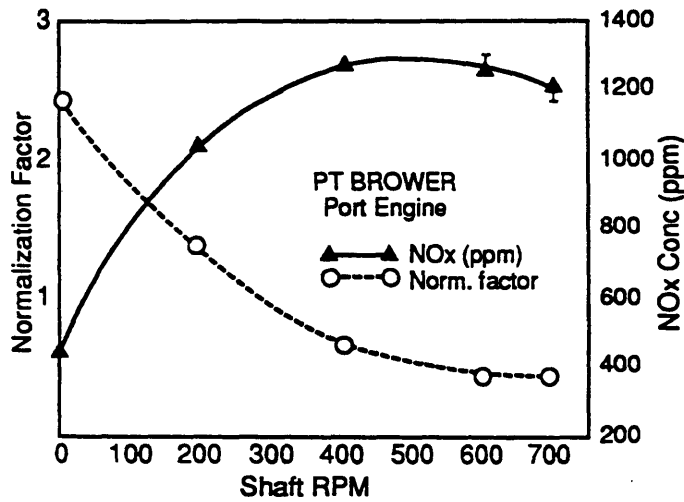
The Coast Guard program is ongoing. To date, the only published results are based on the testing of three Coast Guard PT cutters<sup>37</sup>. Their measured NO<sub>x</sub> volume concentrations increase with engine load, in agreement with Heywood. Figure 26 shows their raw NO<sub>x</sub> test results along with a CARB normalization curve which must be applied to the raw data. The CARB correction factor adjusts the raw data to provide NO<sub>x</sub> concentrations referenced to 15% excess oxygen in the exhaust. This method of normalization has been found by the U.S. Coast Guard to over estimate exhaust emissions and will not be used for comparison purposes in this thesis.

The testing of an LSD-41 Class Amphibious Vessel is the first accomplished on a large, public sector marine vehicle in the United States. It has provided the Coast Guard an opportunity to validate their procedures with a greater tonnage ship than is available in their inventory and adds to the growing data base of at-sea engine emissions measurements.

---

<sup>37</sup> Bentz, Alan P. and Weaver, Elizabeth, Marine Diesel Exhaust Emissions Measured by Portable Instruments, SAE 941784, Sept, 1994, pg. 1-5.

**Figure 26: Coast Guard PT Cutter NO<sub>x</sub> Data**



In his 1994 thesis, Markle validated the LSD-41 Class operating profile using the emission contour maps of the Colt-Pielstick PC4.2B engine. The emission contour plots for the Colt-Pielstick PC2.5V16 diesel installed on the ships of the class are not publicly available. Both models of engines, the Colt-Pielstick PC4.2B and PC2.5 are medium speed, marine engines manufactured by the same company. Table 13 compares the two engines with regard to a number of features. The PC4.2B is a much larger engine, approaching the size of many slow speed diesels. The predicted PC4.2B emissions, determined through use of the LSD-41 Class duty cycle, will be used as a benchmark when compared to measured emissions from a PC2.5V16 diesel engine operating at sea on a LSD-41 Class ship. This is the best benchmark available for the PC2.5V16 engine.

**Table 13: Comparison of Colt-Pielstick PC4.2B and PC2.5V16 Diesel Engines<sup>38</sup>**

<b>Parameter</b>	<b>PC4.2B</b>	<b>PC2.5V</b>
Rated Power per Cylinder	1630 bhP	530 bhP
Rated RPM	400 RPM	520 RPM
Volume Displaced per Cylinder	9654 cubic inches	3527 cubic inches
BMEP (rated)	334 psi	280 psi
Combustion Chamber Volume	894 cubic inches	336 cubic inches
Compression Ratio	11.8:1	11.5:1
Maximum Firing Pressure	2100 psi	1800 psi
Turbocharged?	Yes	Yes
Intercooled?	Yes	Yes
Fuel Injected (Advanced)	13° BTDC	12° BTDC
Number of Strokes	4	4
Intake Air Flow Rate (rated)	67500 SCFM	26520 SCFM
Cylinder Head Shape	Octagonal	Octagonal

Markle used the PC4.2B emission contour plots with generic test cycles and the test cycle he developed from the LSD-41 Class operating profile to estimate specific pollutant emissions. Not surprisingly, the developed duty cycle best matched the emissions calculated from the LSD-41 operating profile. His results are recreated as Table 14. These results will be compared to those measured during seaborne testing in an effort to provide information to support the adequacy of estimating the PC2.5 engine's emissions using the PC4.2 contour maps..

---

<sup>38</sup> Interview with Angelo Mazzenga, Coltec Ind., conducted via telephone on 28 April, 1995.

**Table 14: LSD 41 Class Emission Predictions (g/bhp-hr)<sup>39</sup>**

<b>Prediction Method</b>	<b>NO<sub>x</sub></b>	<b>CO</b>	<b>HC</b>	<b>CO<sub>2</sub></b>
Propeller Curve	8.5	1.5	0.6	475
Duty Cycle	8.3	1.5	0.7	483

#### **4.2 Experimental Goals**

The goal of the experiment was to determine the NO<sub>x</sub> and CO specific emissions for comparison to known trends and proposed regulatory limitations. The testing was conducted in accordance with ISO 8178 Part 1 and 2 using operating points corresponding to the duty cycle developed in Markle for the LSD-41 Class Amphibious Ships.

Summarized, the ISO 8178 procedures specify the measurement and evaluation methods for gaseous and particulate exhaust emissions for diesel engines. Part 1 of the document pertains to steady state measurements conducted on a test bed. Part 2 adopts the procedures introduced in Part 1 for site measurement, including diesels operating on ships at sea. Its purpose is to provide a map of an engine's emissions characteristics.

The use of the relaxed standards of ISO 8178 Part 2 can only be justified in the following cases: 1) when test bed measurements are inappropriate because site conditions cannot be duplicated; 2) when measurement at site is necessary to evaluate actual pollution; 3) when all parties involved agree to site measurement; and 4) if site measurements are being used to check the conformity of used or rebuilt engines to new engine standards. The use of the relaxed ISO 8178 Part 2 procedures for measurement of the LSD-41 Class emissions described in this report are justified by Case 2 above.

The ISO 8178 does not specify equipment to be used in gathering data or locations in the machinery plant at which measurements are to be taken, but it does provide accuracy requirements and guidelines. The accuracy of all measuring instruments should

---

<sup>39</sup> Markle, p.95.

at least meet the maximum tolerance values listed in Table D-1 of Appendix D.

The emissions can be collected in two fashions: the constant volume or the diluted raw stream method. The raw stream method, which is used in most portable emissions analyzers, involves drawing a representative sample from the exhaust flow, adding small amounts of ambient air, and analyzing its contents for volumetric exhaust concentrations. While specific analysis instrumentation are proscribed in the ISO procedures, other systems and analyzers are acceptable if it can be proven that they yield equivalent results.

The ISO 8178 also provides guidance regarding the processing of raw data. All emission analysis methods provide the exhaust concentration as a mole concentration in units of parts per million (ppm) or volume percentage. These measurements have to be converted to a mass basis and then modified to a specific emission using the engine power (units of g/kW-hr or g/bhp-hr). The required data for this calculation are the molecular density of the pollutant, the volume concentration of the pollutant and the mass flow rate of the exhaust stream.

ISO 8178 accepts four procedures for determination of the exhaust flow rate: direct measurement of the exhaust flow, measurement of the air and fuel flows, use of a full flow dilution system, or a theoretical calculation based on a carbon or oxygen balance. The equipment necessary to conduct an experiment is primarily driven by the selection of one of the four methods for determining exhaust flow rate. Due to the inability of the selected portable emissions analyzer to assess CO<sub>2</sub> and gaseous hydrocarbon concentrations, the carbon or oxygen balance approach could not be used. Direct measurement of the exhaust flow was eliminated due to the high exhaust temperatures expected and restrictions on intrusions into the existing machinery and piping. A full flow dilution unit requires large amounts of space and also would have created unnecessary intrusions. With three of the four methods to measure the exhaust flow eliminated, equipment to measure the fuel and air flow rates was included in the experimental set-up.

A detailed description of the equipment used in the experiment is provided as Appendix D. In summary, it consists of five functional groups: 1) in-line flow meters on the fuel supply and returns for each engine to measure volumetric fuel flow; 2) in-line pitot

tubes in the intake air piping to measure differential pressure and volumetric air flow; 3) a manometer and thermocouple in the vicinity of the pitot tube to calculate intake air density; 4) ECOM portable emissions analyzers for each exhaust stack, and 5) an automated data collection system for recording all of the above signals as well as engine RPM and shaft torque (based on signals from the ship's machinery control system).

Additional equipment was supplied by the ship in the form of a barometer and psychrometer on the ship's bridge. This information was used to predict the water content of the incoming air. Although water flow rate is small when compared to the air and fuel mass flow rates, completeness required that it be included.

The ISO 8178 also requires the recording of information which is not used in the emission level calculations, but is important in relating the conditions under which the engine was tested. These include sea conditions, fuel rack readings, days since last hull cleaning, etc. This supporting information is included in Appendix D.

### **4.3 Experimental Constraints**

The two primary constraints on the design of the experiment were time and the ship's operational requirements. Despite early efforts to acquire a dedicated test platform, the experiment was conducted on a platform of opportunity, the USS ASHLAND (LSD-48). The available window corresponded with the ship's sea trial scheduled upon completion of a shipyard repair period and was much earlier than the test team had anticipated. This required substituting similar, less capable equipment available for direct shipment for long lead time units. The impact this had on the quality of the results was small with the exception of one system, the intake air pressure. This issue is discussed in greater detail in the trip report included as Appendix F.

The most demanding constraint was the need to minimize interference with the ship's existing systems and the impact of the emissions testing on the events of the sea trial. The solution to these two problems will be described separately.

Due to limitations in the amount of testing equipment on hand and the number of test personnel available, a decision was made to test only two of the ship's four MPDEs.

The selected engines were 1A and 1B, both located in Main Machinery Room #1 and attached to the starboard shaft.

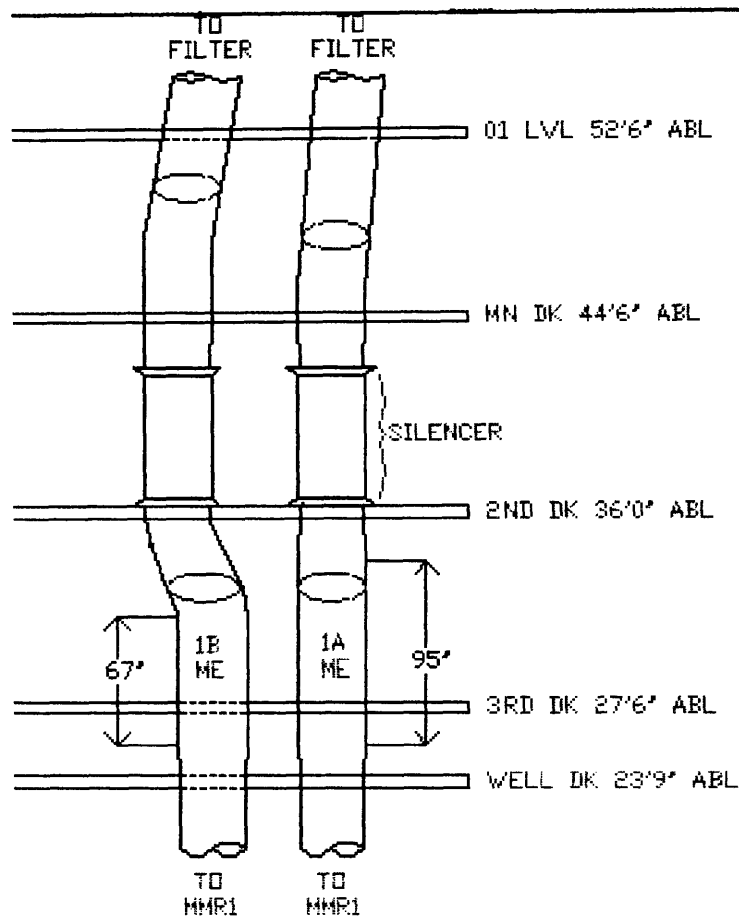
In order to minimize interference with ship machinery, instrumentation used during the ship's Acceptance Trials and Fuel Consumption trials was used whenever possible. The ship was designed and built to support measurement of main engine fuel consumption and remote monitoring of shaft torque and engine RPM. Flanged spools in the fuel lines were removed for installation of the turbine fuel flow meters, and the electronics for the other measurements were tapped directly into the control console in the main control room. There was a concern that the installed torsionmeter was inadequate for the accuracy requirements dictated in ISO 8178, so manual recording of the propeller pitch angle and shaft RPM was added as a secondary approach for computing the engine's load.

An existing manometer connection on the exhaust piping just aft of the turbocharger exit was used as the entry point for the portable emissions analyzer probe. A valve was screwed into the NPT fitting to secure the probe in place during operations and block the escape of emissions into the space whenever the probe was required to be removed. After consulting with test engineers at Coltec, Inc., it was determined that the maximum exhaust temperature at this station would be 800° Fahrenheit, a temperature sufficiently low to preclude damage to the portable analyzer probe but adequate for ISO 8178 test requirements. The location of the fitting was sufficiently remote to preclude any interference with the crew's normal operation of the engines.

The need to measure the mass air flow presented a more difficult problem. The large dimensions of the intake air piping impeded installation of a hood section containing a flow turbine, which is the preferred approach of the Coast Guard R&D Center. A pitot tube was selected for installation in the vertical run of the intake piping located in the uptake room. Figure 27 is a sketch of this piping, indicating the lengths of pipe run available. To ensure fully developed turbulent air flow in the pipe, the straight distance below and above the installation point had to be a minimum of 1.5 times the diameter of the pipe. The intake piping was a non-standard size, consisting of rolled 0.12 inch thick

stainless steel pipe with a diameter of approximately 38 inches. The lower run, below the intake silencer, was selected as the best site for installation of the pitot tube.

**Figure 27: Sketch of Intake Air Piping in Uptake Room**



Because of the inclusion of the filters and intake silencers in the combustion air intake piping, the density of the air in the vicinity of the pitot tube was also required to be measured in order for the mass flow rate of the intake air to be computed. An additional boss fitting was added to support a manometer and thermocouple probe.

The position of the uptake room, in which the vertical run of pipe sketched in Figure 27 was located, is above and aft of Main Machinery Room #1. Access to this space is denied during engine operation since the exhaust piping also is routed through the space. This additional constraint, inaccessibility to the equipment during engine operation, prompted the team to record all of these signals remotely.



All details regarding the equipment installed are included as Appendix D.

The test procedures for the USS ASHLAND trials are detailed in the Shipboard Main Propulsion Diesel Emission Test Aboard U.S. Navy LSD-41 Class Amphibious Ships Test Plan, Appendix E. The test was planned to be conducted in calm, deep water. "Deep water" is a term which is a function of the vessel's maximum cross-sectional area or maximum speed. The minimum water depth for negligible wave making and residual resistance can be calculated using equation (12) or (13)<sup>40,41</sup>:

$$Depth (ft) = \frac{(Maximum Speed (ft/sec))^2}{0.10 * gravity} \quad (12)$$

or

$$Depth (ft) = 3 * \sqrt{Cross Sectional Area (ft^2)} \quad (13)$$

The result with the greatest depth is used. The minimum depth for testing is 236.4 feet or approximately 34 fathoms. The supporting calculations are included in Appendix E. The weather conditions are considered calm if the significant wave height is less than 2 feet and the wind speed is less than 15 knots.

Numerous test blocks including multiple speed changes were designated. Separate blocks were designed for each shaft configuration, one or two engines per shaft. The speeds were based on the duty cycle developed by Markle and are listed in Table 14.

Each block consist of five to seven runs, each run at a specified operating point. The order of the speed changes in each block were randomized to minimize the effect of non-measurable external factors on the results. Tables 15 and 16 list the blocks for each shaft configuration.

Blocks 1 through 3 were scheduled to be conducted during the midwatch (hours

---

<sup>40</sup> Conversation with Douglas Griggs, Naval Surface Warfare Center, Carderock Division, initiated on 15 February, 1995.

<sup>41</sup> Principles of Naval Architecture Volume II, Society of Naval Architects and Marine Engineers, 1988, pp.42-50.

between midnight and 0600) on 15 February, 1995. The need to control the ship's speed and heading precluded simultaneous testing with any of the ASHLAND's other sea trial requirements. It was felt that the midwatch would offer the longest, uninterrupted stretch of time which could be made available for the experiment without negatively impacting the length of the sea trial period. Blocks 4 through 6, with two engines per shaft, were scheduled for the same time period on 16 February, 1995.

**Table 15: List of Operating Points (Converted to Speeds)**

<b>Mode</b>	<b>Ship Speed (knots)</b>	<b>Engines per Shaft</b>	<b>Propeller Pitch %</b>	<b>Shaft RPM</b>	<b>Time Factor</b>
1	0	0	0	64	0.083
2	5	1	52	64	0.064
3	5	2	52	64	0.128
4	10	1	100	66	0.077
5	10	2	100	66	0.141
6	15	1	100	102	0.051
7	15	2	100	102	0.109
8	17	1	100	116	0.040
9	17	2	100	116	0.16
10	20	2	100	138	0.093
11	24	2	100	165	0.054

**Table 16: Run Sequence (Single Engine Per Shaft)**

Block #	Run Name	Ship Speed (knots)	Propeller Pitch %	Shaft RPM
1	1-1-X	10	100	66
	1-2-X	17	100	116
	1-3-X	15	100	102
	1-4-X	5	52	64
	1-5-X	IDLE	0	64
2	2-1-X	15	100	102
	2-2-X	10	100	66
	2-3-X	IDLE	0	64
	2-4-X	5	52	64
	2-5-X	17	100	116
3	3-1-X	IDLE	0	64
	3-2-X	5	52	64
	3-3-X	15	100	102
	3-4-X	10	100	66
	3-5-X	17	100	116

**Table 17: Run Sequence (Two Engines Per Shaft)**

Block #	Run Name	Ship Speed (knots)	Propeller Pitch %	Shaft RPM
4	4-1-X	IDLE	0	64
	4-2-X	15	100	102
	4-3-X	17	100	116
	4-4-X	10	100	66
	4-5-X	20	100	138
	4-6-X	24	100	165
	4-7-X	5	52	64
5	5-1-X	100	165	
	5-2-X	20	100	138
	5-3-X	10	100	66
	5-4-X	5	52	64
	5-5-X	15	100	102
	5-6-X	IDLE	0	64
	5-7-X	17	100	116
6	6-1-X	15	100	102
	6-2-X	5	52	64
	6-3-X	IDLE	0	64
	6-4-X	20	100	138
	6-5-X	10	100	66
	6-6-X	17	100	116
	6-7-X	24	100	165

Note: X represents MPDE 1A or 1B.

All test runs within a block follow the same pattern for each operating point defined by an engine torque and engine speed. The run cycle begins with acceleration or deceleration from the previous speed to the test speed required for the current run. Once the engine was nearly stabilized (as determined by a constant exhaust temperature reading from the exhaust monitoring equipment), exhaust readings were taken every minute for a minimum of five minutes. During this interval, the ship maintained steady course and speed and limited rudder angles to less than ten degrees. At the end of the data collection, the ship was signalled to proceed to the next speed in the sequence.

The machinery plant control system allows the propeller pitch and shaft RPM to be controlled locally in Main Control or remotely in the pilot house. During normal operation, the control would be resident on the bridge and the throttleman would constantly adjust the throttle position in an attempt to maintain speed as reported by the "dummy log" (a constantly updated electronic means of predicting the ship's speed over ground). During the experiment, throttle control was passed to Main Control and constant pitch percentage and shaft RPM were maintained. It was deemed more important to match the duty cycle operating points than the corresponding ship's speed.

At completion of the experiment, at least fifteen NO<sub>x</sub> and CO measurements for each operating point were collected. These readings were accompanied by the associated air flow, fuel flow and engine load data necessary to convert the raw emissions data to a useable form.

## **Chapter 5: Analysis and Results**

### **5.1 Analysis Approach**

The air intake vacuum in the vicinity of the pitot tube installation was not available for the analysis (see Appendix F). A sensitivity calculation was performed using the most conservative estimate for the pressure drop in the air intake piping, based on known alarm set points and the engine manufacturer's predictions. It was determined that the largest error which could be introduced in the calculation of the dry intake air density was less than one percent. Based on this conclusion, the ambient air pressure was used as the total static pressure in determination of the dry air density.

Volumetric air flow rate data was not available for MPDE 1B. While the MPDE 1A pitot tube assembly performed satisfactorily, data was only available for three operating points (Appendix F refers). These differential pressures were converted to volumetric air flow rates using equation (14).

$$Q_{air} (SCFM) = 128.8 \cdot K \cdot D^2 \cdot \sqrt{\frac{P + \Delta P}{(T + 460) \cdot S_s}} \quad (14)$$

where  $D$  is the diameter of the intake pipe in inches,

$P$  is the static line pressure in psia,

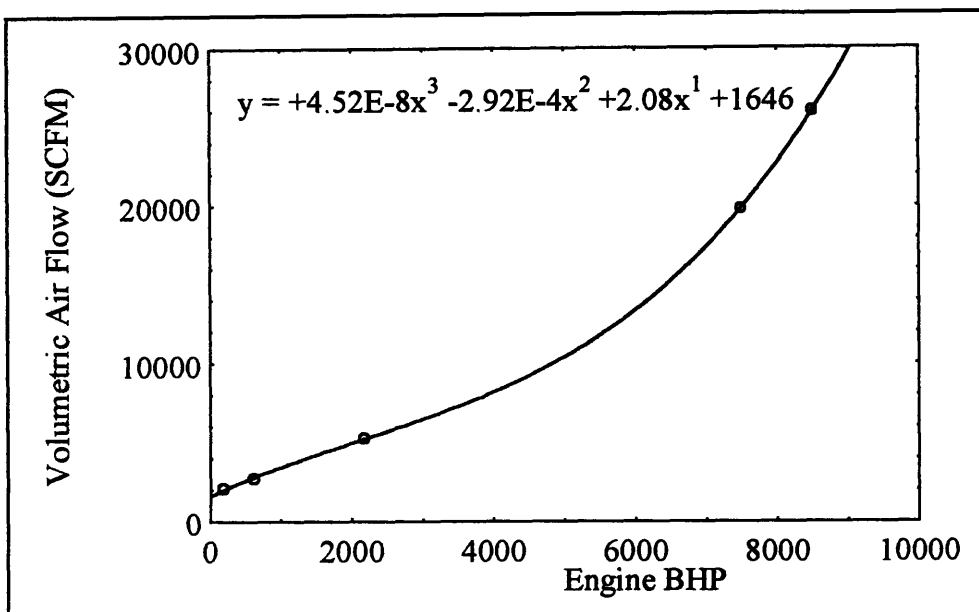
$T$  is the temperature in Fahrenheit,

$S_s$  is the specific gravity at 60° F

and  $K$  is a manufacturer defined flow coefficient which is a function of the pitot tube diameter.  $K=0.757$  for this application.

Volumetric air flow rates for two additional data points, idle and full load, were contributed by COLTEC, Inc, the diesel engine manufacturer. Using these five points, a best fit curve was drawn establishing a relationship between engine brake horsepower and volumetric air flow rate in units of Standard Cubic Feet per Minute (SCFM). This curve is included as Figure 28.

**Figure 28: Volumetric Air Flow Rate versus Engine Load**



Validation of the measured engine parameter data was accomplished by comparing the measured volumetric fuel flow rate and engine brake horsepower results obtained during the LSD-41 Class Standardization Trials. The deviations were minor and confidence in the measured data is high. Best fit curves were drawn through all of the fuel flow rate data and a relationship between volumetric fuel flow rate (in units of gallons per minute) and engine load was established (Figure G-2). Supporting calculations and plots are included in Appendix G.

Determination of the water content of the intake air was based on measured ambient and local (in the vicinity of the pitot tube) air conditions and the fact that the partial pressure of the water vapor should remain constant at both conditions (same water density in the same one cubic foot volume). The relative humidity was measured on the bridge, along with the atmospheric pressure. The water vapor partial pressure was calculated using equation (15):

$$\% \text{ Relative Humidity} = \frac{P}{P_s} \cdot 100 \quad (15)$$

where  $p$  is the partial pressure of the water vapor and  $p_s$  is the saturation pressure which is a function of the ambient temperature.

At the pitot tube site, the dry bulb temperature was measured by the adjacent thermocouple assembly. The local pressure was determined by adding to the bridge barometer atmospheric pressure an additional pressure term based on the height from the pitot tube to the bridge wing. The dry air partial pressure at the pitot tube was computed from equation (16):

$$P = p_{DA} + p \quad (16)$$

where  $P$  denotes the total pressure and  $p_{DA}$  is the partial pressure of the dry air.

With the total pressure and the partial pressure of the water vapor available, the absolute humidity value can be calculated from the following equation (17):

$$\omega = \frac{18.01 \cdot p}{28.967 \cdot (P-p)} \quad (17)$$

where  $\omega$  denotes absolute humidity in units of lb. water vapor per lb. dry air, 18.01 is the molecular weight of water vapor and 28.967 is the molecular weight of dry air. The dry air density can be found using the Ideal Gas Law, equation (18):

$$\rho = \frac{(P-p)M}{R_u T} \quad (18)$$

where  $R_u$  is the universal gas constant,  $T$  is the air temperature and  $M$  is the molecular mass of the medium, air. The dry air density is combined with the volumetric air flow rate to find the intake air mass flow rate in units of kg/hr.

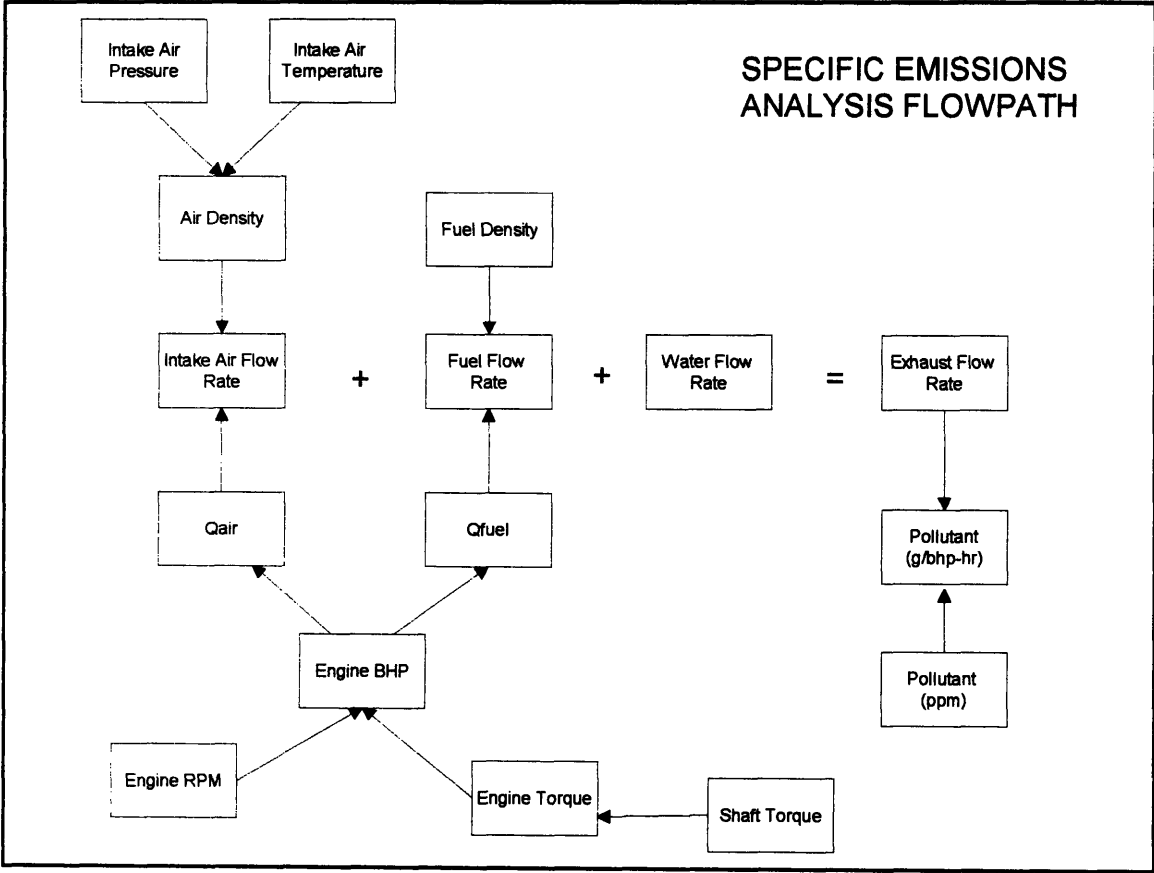
The absolute humidity is used to determine the mass flow rate of the water vapor entrained in the intake air using equation (19). While this amount is significantly less than either the fuel or air flow rate, it was included in the calculation for completeness.

$$m_{H_2O} = Q_{air} \cdot \omega \cdot \rho_{dry\ air} \quad (19)$$



The computation of the exhaust mass flow rate was carried out as outlined in Figure 29. While a rigorous statistical analysis could not be conducted due to the small number of sample data available, an attempt to check the sensitivity of the exhaust flow rate calculation to variations in the input data was undertaken. One standard deviation from the expected value was used to bound estimates for inputs values of the raw fuel flow, engine RPM, intake air temperature, and shaft torque data. The exhaust flow rate calculated with these inputs varied little from the flow rates calculated from the raw data averages (refer to Appendix G). Fluctuations in the raw data measurements, within one standard deviation, were shown to be insignificant.

**Figure 29 : Specific Emissions Analysis Flowpath**



To complete calculation of the specific emissions, the dry CO, NO and NO<sub>2</sub> molar concentrations had to be converted to "wet" concentrations by including the effects of entrained water using Equation (20).

$$x_{i_{wet}} = (1 - x_{H_2O}) x_{i_{dry}} \quad (20)$$

where  $x$  represents a mole fraction of pollutant "i". The mole fraction of water was obtained using equation (21), taken from Heywood. This equation is valid when all species used in the calculation have been measured with the same background moisture (in this case-dry).

$$x_{H_2O} = 0.5 \cdot y \cdot \frac{x_{CO_2} + x_{CO}}{(x_{CO}/(K \cdot x_{CO_2})) + 1} \quad (21)$$

where  $x$  represents the molar concentration of the gas,  $y$  is the H/C ratio of the fuel, (value of 1.8 from Appendix G) and  $K$  is an empirical constant determined from exhaust gas composition data. Typical values range from 3.8 to 3.5<sup>42</sup>, and 3.5 was chosen for this calculation. Supporting calculations are included as Appendix G.

The ECOM Portable Emission Analyzers were equipped to measure oxygen, CO, NO and NO<sub>2</sub> concentrations only. As the molar concentration of the carbon dioxide (CO<sub>2</sub>) was not measured, it had to be estimated. A carbon balance approach was considered inappropriate as the gaseous hydrocarbon concentrations also were not measured and the contribution of the fuel carbon particles to the soot could not be determined. An empirically based equation which provides the volume percentage of carbon dioxide as a function of the oxygen content was used and is presented as equation (22).

$$CO_2\% = CO_{2_{MAX}}\% \cdot \left(1 + \frac{O_2\%}{21\%}\right) \quad (22)$$

---

<sup>42</sup> Heywood, p.150.

where the maximum CO<sub>2</sub> percentage is that which is created at stoichiometric conditions.

The specific emissions are computed using equation (23).

$$\text{Specific Emission (g/bhp-hr)} = \frac{\text{Pollutant (ppm)} \cdot m_{\text{exhaust}} \text{ (kg/hr)} \cdot u}{\text{Engine bhp}} \quad (23)$$

where the term  $u$  has units of grams of pollutant gas/kg of air and is defined by equation (24):

$$u = \frac{4.615 \cdot 10^{-5} \text{ (Mol/M}^3\text{)} \cdot \text{Molecular Weight (g/Mol)}}{\rho_{\text{air}} \text{ (Kg/M}^3\text{)}} \quad (24)$$

The NO<sub>x</sub> specific emission was determined two different ways and compared. In the first, the molecular weight used in the calculation represented a weighted average of the combination of NO and NO<sub>2</sub>. From the literature, it was estimated that the NO<sub>2</sub> would comprise ten percent of the total. The calculation was repeated, computing the specific emissions for each individually and then summing the results. Either method offers possibilities for introduction of errors, yet each provided results within 5 percent of each other. The first method, using a weighted average molecular weight, was selected for presentation of the data.

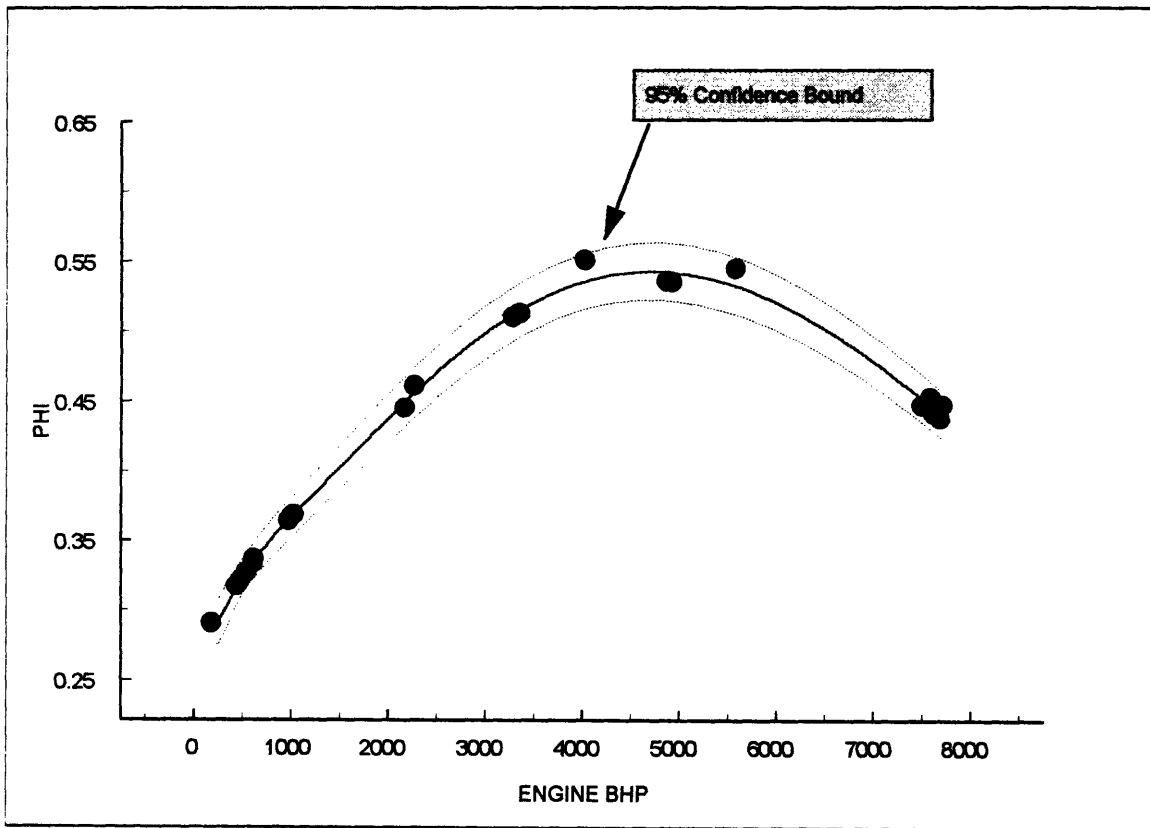
## 5.2 Discussion of Results

Once the measured data was reduced and combined into useable measurements, additional calculations were performed to determine how the measurements compared to expected trends found in the literature. One of the first plots created was engine load vs equivalence ratio, Figure 30. This plot is important for demonstrating the adequacy of the fuel and air measurements upon which the specific emissions are based. The anticipated result is that the equivalence ratio has the greatest value at maximum Brake Mean Effective Pressure (BMEP). The BMEP is a reflection of an engine's ability to do work normalized by the engine size. The work per cycle is divided by the cylinder volume displaced per cycle as shown in equation (25):

$$BMEP = \frac{T_{brake} \cdot n_R}{V_d} \quad (25)$$

where  $T_{brake}$  represents the engine torque,  $V_d$  is the displacement of all engine cylinders and  $n_R$  is the number of crank revolutions for each power stroke per cylinder. This number is 2 for a four-stroke cycle engine, such as the PC2.5V16. Increased work output for a given displaced volume (larger BMEP) requires a greater energy input. The fuel content of the cylinder's contents must increase and the equivalence ratio increases.

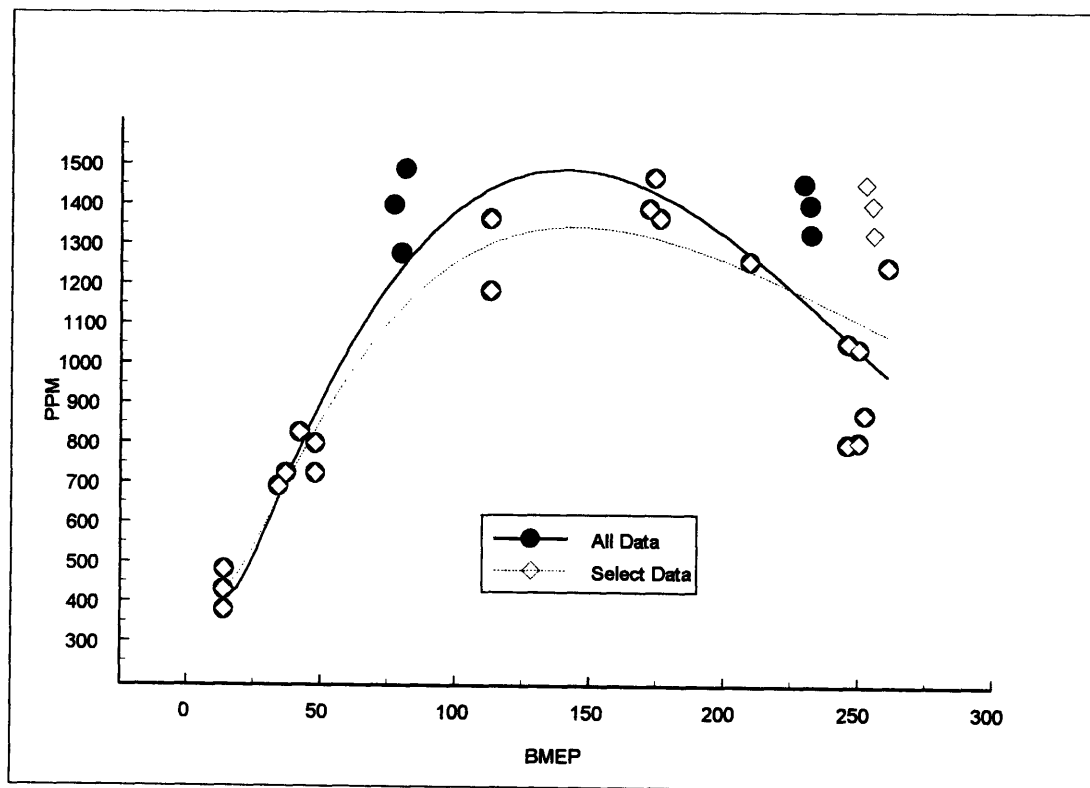
**Figure 30: Equivalence Ratio versus Engine Load**



The maximum BMEP for the LSD-41 Class MPDE is 280 psi at approximately 5000 brake horsepower (BHP). The curve of Figure 30 is a best fit through all of the data points, and it gradually rises to a peak near the 5000 BHP point. The measured air flow, fuel flow and engine load data are considered to accurate reflections of operating conditions during the trials.

The raw emissions data was collected in volumetric concentration units of parts per million (ppm). Figure 31 is a plot of the measured pollutant concentrations as a function of the engine load, characterized by the engine BMEP.

**Figure 31: NO<sub>x</sub> (ppm) versus Engine BMEP**



The NO<sub>x</sub> production rate is primarily a function of combustion temperature, although the air/fuel ratio also affects the rate by influencing the oxygen and nitrogen concentrations. Equation (26) describes the rate of formation of NO, the primary component of NO<sub>x</sub>:

$$\frac{d[NO]}{dt} = K(T) [O_2] [N_2] \quad (26)$$

where bracketed terms denote volume concentration of each species and  $K(T)$  is the equilibrium constant for chemical equilibrium and is a function of temperature. Based on this relationship (equation 26),  $NO_x$  ppm values are expected to increase as combustion temperature increases, which corresponds with increasing BMEP. Figure 31 does not appear to match this description.

Two curves are plotted in Figure 31. The curve which peaks at approximately a BMEP value of 125 psi is a best fit curve for all of the data collected. The second curve (dotted line), is a plot of the data with select points removed. The points deleted are those corresponding to the peak of the first curve (solid line) and represent the data gained through ship testing at a speed of ten knots with only one engine aligned per shaft. Although it appears suspicious to delete all data from one operating point (single engine per shaft alignment at ten knots), it is possible that all of these operating points contain transient data, which will be much greater than the steady state  $NO_x$  values. In all three blocks of runs during the experiment, the speed of ten knots was reached by decelerating from speeds of fifteen or seventeen knots. The higher speeds are close to maximum BMEP, and it is possible that insufficient time was allowed for the engine to completely settle at the slower speed before data was collected.

The second curve, the dotted one, also contains revised BMEP values for the data corresponding to a ship speed of seventeen knots with a single engine per shaft. Review of the measured torque for these data points revealed that the values were approximately five percent lower than the torques determined during Standardization Trials. The measured torque values were adjusted to reflect the predicted BMEP values at this operating point, which is the point of maximum BMEP. Based on the BMEP revisions for this operating point, and the high values of BMEP calculated for the 24 knot operating point, the accuracy of the installed torsion meters must be questioned.

The shape of the dotted curve does not slope gently to a maximum value

corresponding with the greatest BMEP. This would indicate that a phenomenon other than combustion temperature is influencing the rate of NO<sub>x</sub> production. The most acceptable explanation is that the air/fuel ratio is contributing to the rate of production, resulting in a fairly steady rate over a range of high BMEP values. It is also plausible that measurement variations between the two engines for the same operating point and variations between the data measured over separate nights is influencing the shape of the curves in Figure 31. The lower NO<sub>x</sub> figures at the high BMEP values correspond with testing of two engines at a ship's speed of 24 knots, and could be attributed to sea conditions or testing procedure. This theme is further developed in Appendix G. As the NO<sub>x</sub> ppm values do not peak at the maximum BMEP value, the results in Figure 31 should be validated before any action is initiated in response.

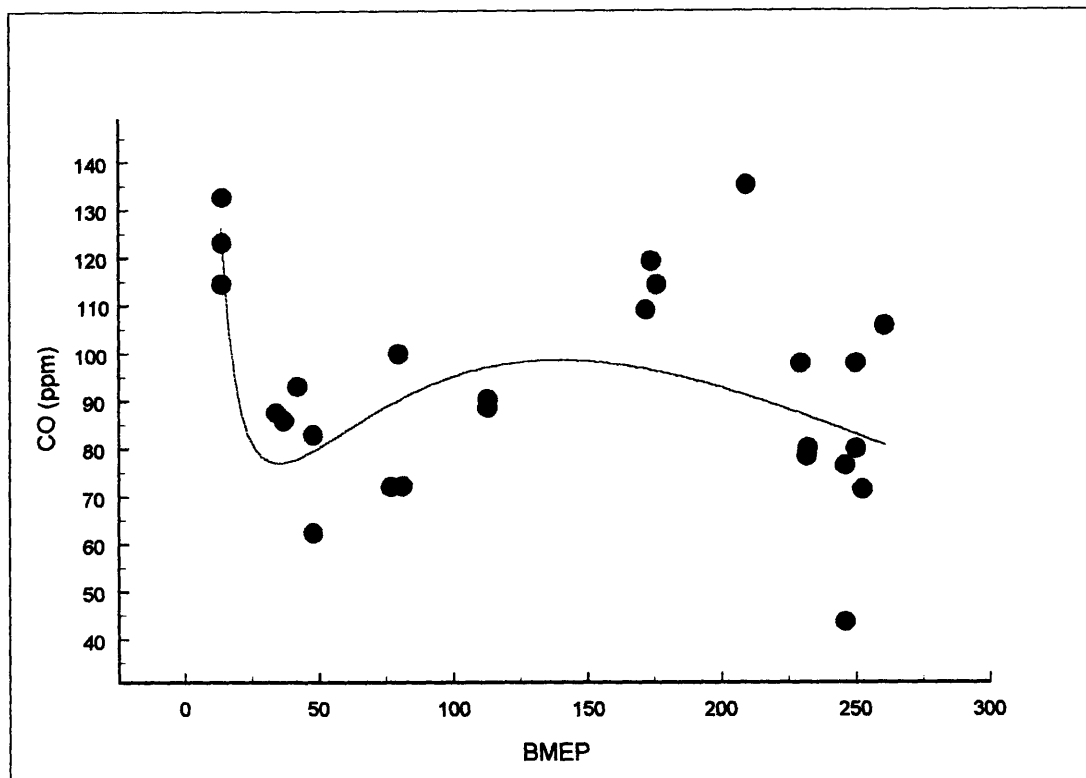
A diesel must run "lean", with more air than necessary for stoichiometric combustion; therefore, CO as a product of combustion is far less a concern in diesel engines than in spark-ignition engines. It was anticipated that levels of CO volume concentration data gathered would be significantly less than the NO<sub>x</sub> concentration. The maximum value of Figure 32 is less than one-half the minimum NO<sub>x</sub> ppm value displayed in Figure 31.

A large source of the marine diesel emissions data available was collected by Lloyd's Register and some of the results were introduced in Chapter 4 as Figures 24 and 25. The curves are plotted for four ranges of maximum engine Maximum Continuous Rating (MCR). Emissions normalized to fuel burned are plotted against the engine load as a percentage of the MCR. The NO<sub>x</sub> data measured during the USS ASHLAND testing is presented in this format in Figure 33. The abscissa of the plot is the engine load normalized as the Power Fraction versus the percentage of MCR.

Two curves are also plotted in Figure 33. Once again, the solid curve, which peaks at a Power Fraction of 0.15, represents all of the measured NO<sub>x</sub> data normalized by the amount of fuel burned. The second curve (dotted line), which has no significant peak, is a plot of the data with the same selected values deleted in an attempt to smooth the curve. The points deleted are those corresponding to the peak of the first curve (solid line) and

represent the data gained through ship testing at a speed of ten knots with only one engine aligned per shaft.

**Figure 32: CO (ppm) versus Engine BMEP**



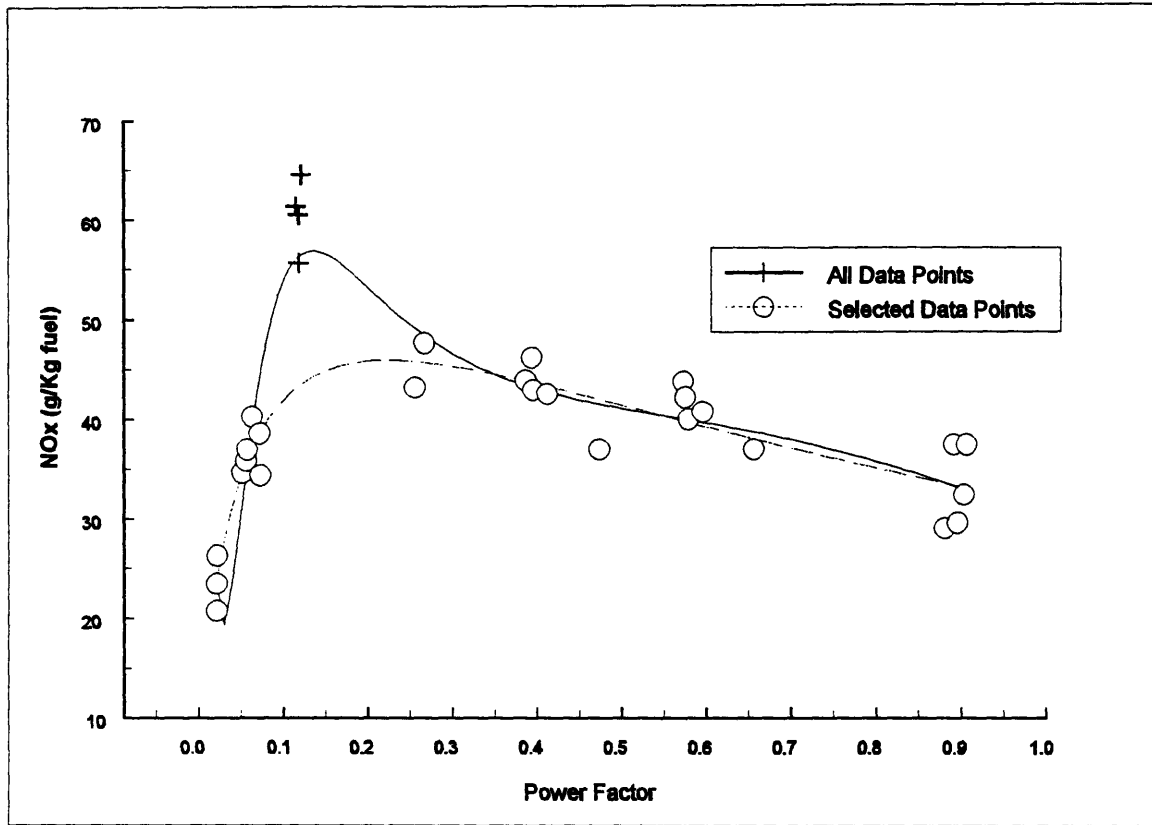
The second curve, without the peak, does resemble the gentle sloping curves if the Lloyd's Register graph for engines with a MCR value greater than 4000 kW (Figure 34). No noticeable trend can be discerned from the curves. At this point, the conclusions from the Lloyd's Register testing bear repeating.  $\text{NO}_x$  formation is particularly sensitive to the engine combustion chamber conditions, which is influenced by many factors including engine design, condition deterioration and age, and operating profile<sup>43</sup>. Additionally, as all of this testing was conducted at sea, it is possible that sea conditions are influencing the data. The sea conditions would include the effects of wave loading on the hull, maneuvering and the impact of different stack designs. Figure 33 should be accepted as

---

<sup>43</sup> Lloyd's Register, pp.5,12.



**Figure 33: NO<sub>x</sub> (g/Kg fuel) versus Engine Load**



**Figure 34: Lloyd's Register NO<sub>x</sub> Results for Engines with MCR > 4000 kW**

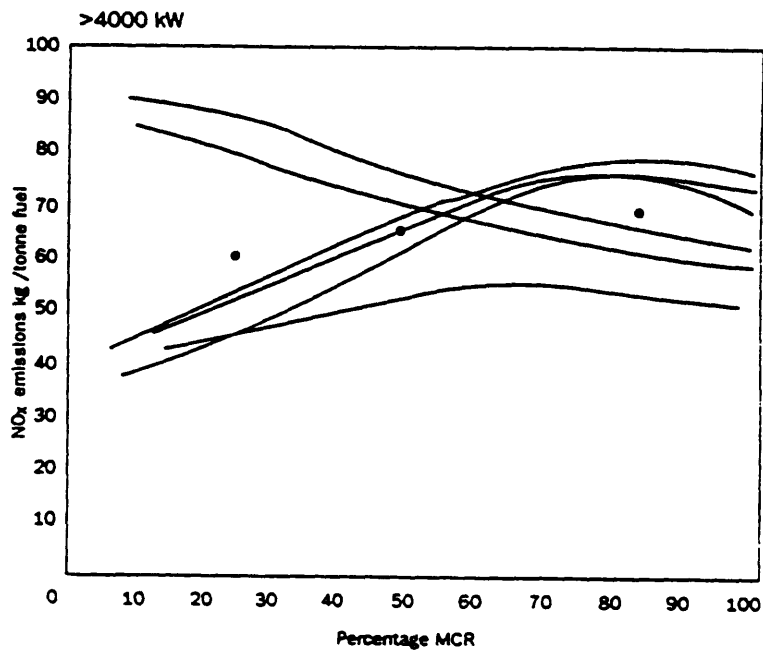


Figure 35: CO (g/Kg fuel) versus Engine Load

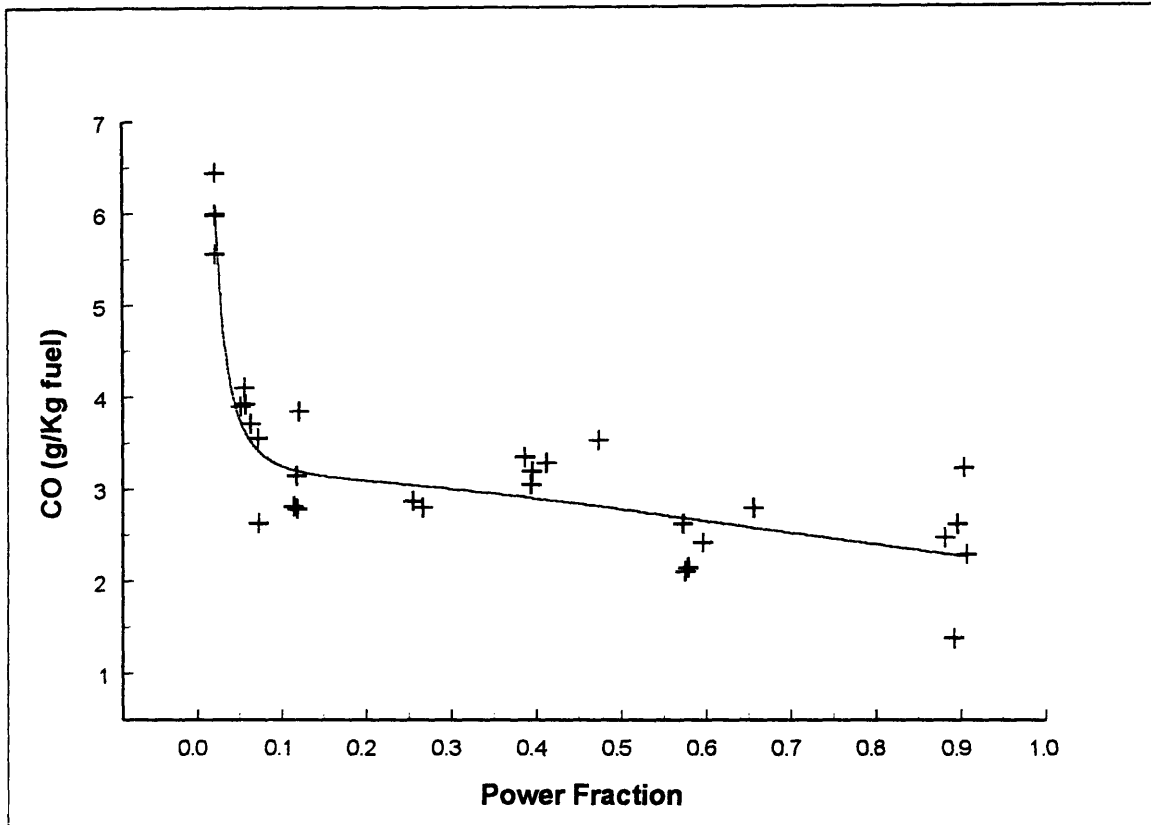
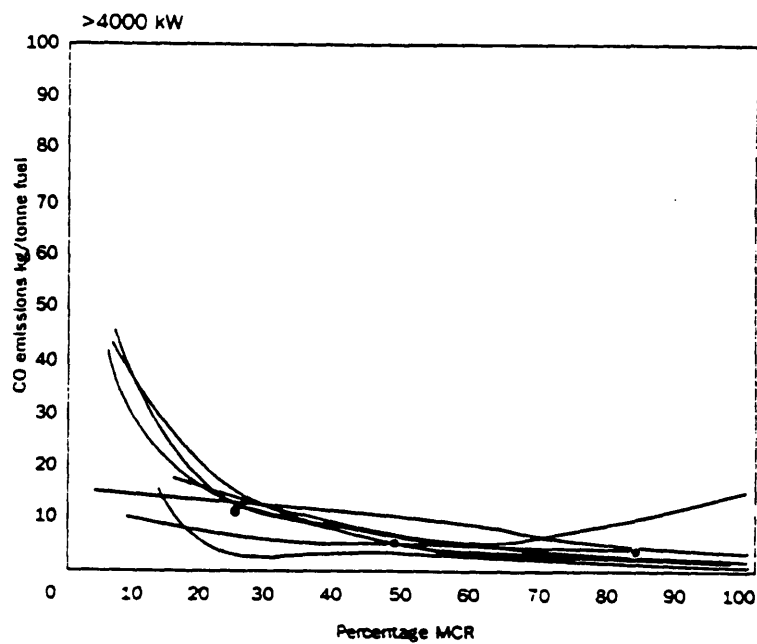


Figure 36: Lloyd's Register CO Results for Engines with MCR>4000 kW



an additional data point in attempting to understand the influences these conditions have on the NO<sub>x</sub> emission profile.

Similarly, Figure 35 is a plot of the measured mass specific emissions of CO as a function of engine load. The high values at low load conditions is apparent in the Lloyd's Register results as well, Figure 36. As the air flow rate on a turbocharged diesel is greatly affected by the engine speed, the air at the idle position may be insufficient for complete mixing with the fuel and create conditions in which the engine burns "rich", less air than necessary for stoichiometric combustion. The data was also normalized as a specific emission, g/bhp-hr. This is the unit of measurement in which the EPA rulemaking limits have been set. The proposed limits for marine engines rated at greater than 50 hP (37 kW) are 9.2 g/kW-hr (6.86 g/bhp-hr)<sup>44</sup> for NO<sub>x</sub>. No maximum limit for CO has been proposed as this pollutant emission level tends to be insignificant in the larger diesel engines. As explained in Chapter One, diesel engines slotted for use in marine vessels will be required to demonstrate that their test bench emissions are below the NO<sub>x</sub> limit when computed as a weighted average using an appropriate duty cycle.

An emissions contour map for the PC2.5V16 engine was not available. Therefore, determination of a cumulative pollutant level based on the time factors of the duty cycle and the measured emissions of the corresponding operating points could not be accomplished. This precluded direct comparison of the experiment's results with both the EPA cumulative limit and the cumulative estimate calculated by Markle for the PC4.2B engine. The NO<sub>x</sub> data collected has been plotted in units of g/bhp-hr in Figure 37 to provide a qualitative assessment of this engine's performance as compared to the EPA limit.

Comparison of individual operating point NO<sub>x</sub> values to the EPA limit indicates that the LSD-41 MPDE will have difficulty meeting the new requirements. While it is understood that the new regulations will not be retroactive, this comparison does imply that the U.S. Navy needs to consider what effects the legislation will have on the current

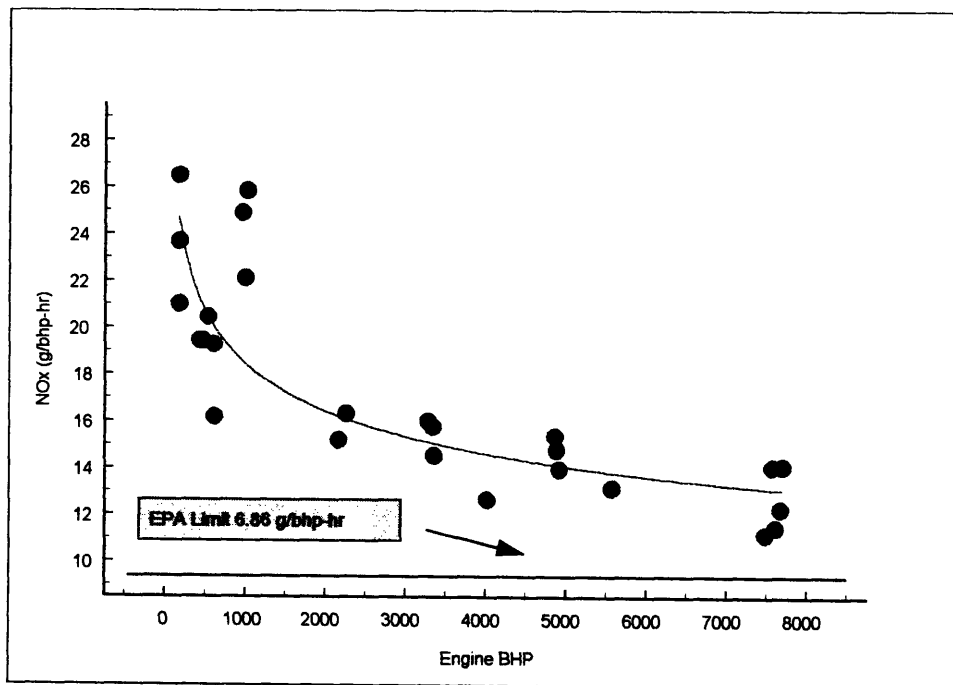
---

<sup>44</sup> EPA, Reducing Pollution from Marine Engines: Information on the Marine Engine Rule Making, p.3.

Navy engine certification process should public vessels be required to comply. The Navy may find it necessary to redirect its policy of selecting candidate engines solely on the basis of efficiency, maintainability and response performance.

Table 18 allows comparison of the CO and NOX emissions at each duty cycle operating point for the Pielstick PC4.2B and PC2.5V engines. Despite the similarity of engine design, the difference in engine size has a large impact on the specific emissions. The PC4.2B emission contour map data points are smaller than the corresponding measured PC2.5 data points. The much greater NO<sub>x</sub> values at low engine loads for the PC2.5V16 are a result of a low g/hr emission value being divided by an even smaller bhp value. These large values will be insignificant in determination of the cumulative weighted average pollutant level.

**Figure 37: NO<sub>x</sub> Specific Emissions versus Engine Load**



A complete PC2.5V16 engine emission contour plot should be developed to support comparison of ISO and naval duty cycles. The significant differences between measured values of the PC2.5 and estimated values from the PC4.2B emissions, especially at light load conditions, suggests that the emission contour maps for the two engines may be sufficiently different as to affect the outcome of the duty cycle analysis. Although the author still anticipates that the naval duty cycle will still best model the ship class operating profile, this result should be validated with the correct emission contour map

**Table 18: Specific Emissions Comparison for Pielstick PC4.2B and PC2.5V Engines**

	Model PC4.2 <sup>45</sup>				Mode PC2.5			
	Power Factor	RPM Factor	NO <sub>x</sub> g/bhp-hr	CO g/bhp-hr	Power Factor	RPM Factor	NO <sub>x</sub> g/bhp-hr	CO g/bhp-hr
IDLE	0	0	0.31	2	0.02	0	23.8	6.1
5*	0.065	0	6	1.2	0.06	0	19.9	2.1
10*	0.158	0.018	8.9	1.04	0.12	0	24.1	1.25
15*	0.468	0.372	13.4	2.1	0.41	0.36	14.3	1.1
17*	0.704	0.511	11.1	1.7	0.597	0.48	14.2	0.84
5	0.032	0	3.1	1.6	**	**	**	**
10	0.078	0.018	6.5	1.2	0.07	0	17.4	1.4
15	0.234	0.372	11.9	1	0.265	0.39	15.4	0.90
17	0.352	0.511	12.6	2	**	**	**	**
20	0.612	0.728	10.8	1.5	**	**	**	**
24	1.0	1.0	8	0.82	0.90	1.015	12.43	0.96

\* Single Engine per Shaft Alignment.

\*\* Data not available.

---

<sup>45</sup> Markle, p. 157.

## **Chapter 6: Conclusions and Recommendations**

The purpose of this thesis was two-fold: 1) to develop an operating profile for the high speed diesel engines on a naval combatant, and 2) to validate the U.S. Coast Guard Research and Development Center's procedure for measuring marine emissions at sea using a portable emissions analyzer. Both of these themes contribute to a larger one, increasing knowledge of the unique aspects of marine diesel emissions.

Chapters Two and Three concentrated on the development of an appropriate test cycle for the Isotta Fraschini engines installed on the MCM-1 Class Mine Hunters. The resulting duty cycle was as different from that developed by Markle for the LSD-41 Class Amphibious Ships as are the vessels themselves. This observation serves to emphasize the point that not only are duty cycles developed from commercial ship operations inappropriate for modeling naval vessel operations, but that separate duty cycles may be necessary for naval ships with differing missions.

Future EPA and international regulations will require engines to prequalify for emission levels by demonstrating performance on a test bed using a predetermined test cycle. This author recommends that the U.S. Navy continue to develop mission specific duty cycles for use in its own diesel engine certification program. The appropriate number of missions which need to be modeled have not yet been determined. On the basis of this thesis and Markle's work, a minimum of two can be identified: the amphibious mission and the mine warfare mission. One can anticipate two others, the auxiliary ship mission and the auxiliary small craft mission.

The method for determining the duty cycles for each recognized mission should parallel the efforts of Chapters Two and Three, although the data collection efforts should be automated. There are numerous initiatives being discussed in Naval Sea System Command regarding instrumentation of a few LSD-41 Class ships as a result of similar recommendations offered by Markle. This effort should be extended to include all naval ship classes, including those propelled by gas turbine engines. Regulation of gas turbine engines has not been proposed, but as increased numbers of marine vessels are being

designed with gas turbines, it is foreseeable that regulation will follow.

Awareness of a naval ship class duty cycle derived from its operating profile will also prove invaluable when trade-offs must be considered in an effort to reduce engine emissions. A revised operating profile can be mapped on a test bench emission contour plot and the results can be quantitatively compared. A quantitative assessment of the contributions of the operating profile to the engine's emissions is invaluable.

As emission contour plots for neither the Pielstick PC2.5 or Isotta Fraschini engines were available, validation of the naval duty cycle for the LSD-41 and MCM-1 Classes were completed using emission data for similar diesel engines. Chapters Four and Five document the measurement of MPDE emissions from a LSD-41 Class ship operating at sea. The NO<sub>x</sub> results of the experiment indicate that the actual emissions contour plot of the PC2.5V16 engine may be different from that of the engine used to compare the naval and generic duty cycles (the PC4.2B engine). It is recommended that emission contour plots be developed for both the Pielstick PC2.5 and Isotta Fraschini engines and the duty cycle comparisons be repeated. The author does not predict that the results of the analysis will be affected: naval duty cycles model naval ship operations much closer than a duty cycle developed for commercial vessels.

The measurement of exhaust emissions from a LSD-41 Class vessel was conducted at sea under rushed conditions and under the leadership of a naval officer inexperienced in shipboard test instrumentation. Despite numerous setbacks, some very important data was gathered and a procedure for instrumenting and testing this ship class was demonstrated.

The specific emission data gathered indicate that the emissions performance of the engine is inadequate to satisfy potential EPA limits. This should not be surprising as the PC2.5 engine was designed in the 1970's and early 1980's when the design emphasis was on reducing fuel consumption.

The author also discovered that the data base of marine emission measurements is incomplete and that some of the included NO<sub>x</sub> data does not appear to fit known diesel emission trends. This occurrence cannot be easily explained and warrants further at-sea

testing to investigate the aspects of the marine environment which may contribute.

Further testing of naval ships at sea may be deemed unnecessary by naval officials in light of the direction that EPA regulations are taking. If funding is provided to support at-sea testing in an attempt to build an usable data base, the author recommends that diesel emissions testing be incorporated into the ship's schedule to allow uninterrupted testing. The instrumentation plan of this thesis was designed to minimize intrusion into ship's systems and interference with normal machinery operation. It could easily be incorporated into sea trial testing, providing emissions data for every ship of the class. A quick ship check onboard a MCM-1 Class ship also indicated that the instrumenting could be accomplished in a similar fashion on that class as well.

Deletion of the air flow rate measurement would further reduce the complexity of the instrumentation. A carbon or oxygen balance method for determining the exhaust mass flow rate would be appropriate if the portable emissions analyzer was configured to provide CO<sub>2</sub> and combustible concentrations. Removal of the pitot tube, thermocouples and vacuum transducers can be equated to adding the portable emissions analyzer to the instrumentation required to conduct a fuel consumption trial. Pairing of these two tests would lengthen the total time the tested platform must remain at sea, but would eliminate costs associated with conducting two separate tests. The end result is a more complete data base to use for validation of emission models and to incorporate into ship and engine performance trade-off studies.

These trade-off studies would be best accomplished using the mission specific duty cycle and test bench derived emission contour maps. The use of generic duty cycles based on commercial ship operations for modeling of naval ship operations may lead to over-estimation of the pollution contributions of naval diesel engines.



## **References**

Bentz, Alan P. and Weaver, Elizabeth, Marine Diesel Exhaust Emissions Measured by Portable Instruments, SAE 941784, Sept, 1994.

Cartellieri, Wolfgang P. and Wachter, Wolfgang F., Status Report on a Preliminary Survey of Strategies to Meet US-1991 HD Diesel Emission Standards Without Exhaust Gas Aftertreatment, Society of Automotive Engineers, Paper Number 870342, 1988.

"Clean Air Act", 42 U.S.C.A., §§ 7401 to 7671q, as amended 1990.

Colt-Pielstick Sales Engineering Data - Marine, Coltec Industries, Fairbanks Morse Engine Division, 1991.

"Control of Air Pollution; Emissions of Oxides of nitrogen and Smoke From New Nonroad Compression-Ignition Engines at or Above 50 Horsepower", Federal Register, Vol.58, No. 93, 17 May 1993.

"Control of Air Pollution: Emissions Standards for New Gasoline Spark-Ignition and Diesel Compression-Ignition Marine Engines; Proposed Rules", Federal Register, Volume 59, No.216, 40 CFR Parts 89 and 91, November, 1994.

"Designers Anticipate Engine Emission Controls", Motor Ship, August, 1992.

Diesel Engines Combustion Air and Exhaust System Test, LSD-49 Test Procedure 5B259C401, Avondale Shipyard, April, 1994.

"Dock Landing Ship LSD 41 Class - Arrangement of Combustion Exhaust System", NAVSEA Drawing 259-4799876, 24 november, 1982.

"Dock Landing Ship LSD 41 Class - Stack Arrangement & Detail", NAVSEA Drawing 162-4799869, 29 May 1981.

English, R. E. and Swainson, D. J., "The Impact of Engine Emissions Legislation on Present and Future Royal Navy Ships", Presented at INEC 1994 Cost Effective Maritime Defense, 31 August - 2 September, 1994.

Environmental Protection Agency Information Sheet, Reducing Pollution from Marine Engines: Information on the Marine Engine Rulemaking, released October 31, 1994.

Ghoniem, Ahmed F., Fundamentals, Modeling and Computations in Combustion, MIT Class Notes, March, 1994.

Goodwin, Michael J., Experimental Design on Marine Exhaust Emissions, Prepared by MAR, Inc., Rockville, Maryland, for U.S. Department of Transportation, U.S. Coast Guard Research and Development Center, October 1994.

Griggs, Douglas B. and Bono, Vincent J., USS RUSHMORE (LSD 47) Fuel Economy, Builder's and Acceptance Trials, David Taylor Research Center, Bethesda, Maryland, October, 1991.

Heywood, John B., Internal Combustion Engine Fundamentals, McGraw-Hill, Inc., 1988.

International Maritime Organization, Sub-committee on Bulk Chemicals, Report of the Twenty-Fourth Session: Annex 8 Draft Technical Guidelines for NOx Requirements under the New Annex for Prevention of Air Pollution, 7 October, 1994.

International Maritime Organization, "Draft Technical Guidelines for NO<sub>x</sub> Requirements under the New Annex for Prevention of Air Pollution", October 7, 1994.

ISO/DP 8178-4 Reciprocating Internal Combustion Engines- Exhaust Emission Measurement, Part 4: Test Cycles for Different Engine Applications, August, 1992.

ISO/DP 8178-1 Reciprocating Internal Combustion Engines - Exhaust Emission Measurements; Part 1: Test Bed Measurement of Gaseous and Particulate Exhaust Emissions from RIC Engines., August, 1992.

ISO/DP 8178-2 Reciprocating Internal Combustion Engines - Exhaust Emission Measurements; Part 2: At Site Measurement of Gaseous and Particulate Exhaust Emissions from RIC Engines -Special Requirements for using ISO 8178-1 at Site, August, 1992.

Klitsch, Michael and Liu, Wayne, USS SCOUT (MCM-8) Results of Standardization, Locked and Trialed Shaft Trials, Carderock Division, Naval Surface Warfare Center, CARDEROCKDIV-92/008, Bethesda, Maryland, May, 1992.

Lloyd's Register Engineering Services, Lloyd's Register of Shipping, Marine Exhaust Emissions Research Programme: Steady State Operation, London, England, 1990.

Markle, Stephen P., Development of Naval Diesel Engine Duty Cycles for Air Exhaust Emission Environmental Impact Analysis, Massachussets Institute of Technology, 1994.

Morgan, Edward J., "Duty Cycle for Recreational Marine Engines", Society of Automotive Engineers, Paper no. 901596, 1990.

MCM Countermeasures Ship (MCM) Preliminary Design Hull Form Development Report (C), Naval Sea System Command report C-6136-78-31, February, 1979 (unclassified sections only).

MCM-1 Class Ship's Information Book, Volume II, S9MCM-AC-SIB-020/MCM-3, Naval Sea Systems Command, Washington D.C., not dated.

Principles of Naval Architecture, Volume II, Society of Naval Architects and Marine Engineers, Jersey City, New Jersey, November, 1988.

Ships and Aircraft of the United States Fleet, U.S. Naval Institute, Annapolis, Maryland, 1993.

Stapersma, D., The Importance of (e)Mission Profiles for Naval Ships, Cost Effective Maritime Defence Conference, Paper No. 6, 31 August-2 September, 1994.

United States Environmental Protection Agency, "Air Pollution from Marine Engines to be Reduced", Environmental News, 31 October, 1994.

Wark, Kenneth, Thermodynamics, Fourth Edition, McGraw-Hill Publishers, 1983.

# Appendix A: Sample Logs

This appendix contains blank sample ship log sheets representative of those reviewed to develop the MCM-1 Class operating profile described in Chapter 2.

Figure A-1: Ship Deck Log Sheet

**SHIP'S DECK LOG SHEET**

IF CLASSIFIED STAMP SECURITY MARKING HERE

USE BLACK INK TO FILL IN THIS LOG

SHIP TYPE: DA HULL NUMBER: 012 YEAR: 40 MONTH: 7 ZONE: 14 DAY: 14

USS ARDENT ATTPASSAGE FROM San Francisco, CA TO Portland, ME

CLASS: U HANNO: U

POSITION	ZONE	TIME	POSITION	ZONE	TIME	POSITION	ZONE	TIME
0800			1200			2000		
L		BY	L		BY	L		BY
λ		BY	λ		BY	λ		BY

LEGEND  
 1 - CELESTIAL  
 2 - ELECTRONIC  
 3 - VISUAL  
 4 - D. R.

TIME	OWNER	CSE	SPEED	DEPTH	RECORD OF ALL EVENTS OF THE DAY
18 - 21	22 - 29	30 - 32	33 - 38	37 - 40	41
12-16 (CONT'D)					
1500	SSTOP				
	RAMID				
	L30R				
	P/R 2				
1503	S/A 3				
	P/A 3				
1505	ASTOP				
	R30R				
	L30R				
	P/A 2				
1506	S/B				
	ASTOP				
	R30R				
	S/A 2				
1508	P/R 1				
	ASTOP				
	L30R				
1509					CO IS ON THE BRIDGE
1510	RAMID				
1512					SET SPECIAL SEA AND ANCHOR DETAIL LTJG WATERMAN HAS THE CONN
	A/A 6				
1514					LT CLSON HAS THE DECK
					<i>Michael R. Graham</i> MICHAEL R. GRAHAM, LTJG
12-16 (CONT'D)					
1520	R30R				ASSUMED THE WATCH, UNDERWAY AS BEFORE
1521	S/B	1300			
1530					FOUNDING AND SECURITY REPORTED ALL SEA

REPORT SYMBOL: (OPNAV 3100-10)

IF CLASSIFIED STAMP REVIEW / DECLASSIFICATION DATE HERE  
U.S.G.P.O. 1988-107-133

IF CLASSIFIED STAMP SECURITY MARKING HERE

## Figure A-2: Engineering Log Sheet

ENGINEERING LOG				(9.77 EDITION) (IS OBSOLETE)		CLASSIFICATION			
NAVSEA 3120/28 (REV. 10-81) S/N 0116-LF-031-2115						UNCLAS			
U.S.S. <u>ARDENT</u>				HULL NUMBER		<u>MCM-12</u>			
DAY	MONTH	YEAR	TIME ZONE	TIME ZONE CHANGE TO	TIME ZONE CHANGE FROM				
<u>09</u>	<u>AUG</u>	<u>94</u>	<u>+5R</u>						
<del>AT/PASSAGE FROM</del> <u>PORTSIDE T00 COASTAL SYSTEMS ENGINEERING STATION, PANAMA CITY, FL</u>				<del>PASSAGE TO</del>		TOTAL MILES TRAVELED TODAY			
						<u>62.0</u>			
EQUIPMENT STATUS <small>(Need not be completed for continuing pages)</small>									
MAIN ENGINES		PLANT STATUS		BOILERS					
<u>SECURED</u>		<u>COLD IRON</u>		<u>N/A</u>					
GENERATORS			STEERING ENGINES COMBINATION						
<u>#16 SSDGINS STANDBY</u>			<u>SECURED</u>						
DAYS OUT OF DRY DOCK		CATAPULT STATUS (CV's Only)		DAYS SINCE LAST HULL CLEANING					
<u>501</u>		<u>N/A</u>		<u>501</u>					
DRAFT FWD	DRAFT AFT	DRAFT MEAN		TONS					
<u>11'6"</u>	<u>12'0"</u>	<u>12'9"</u>		<u>1400</u>					
LIQUID LOAD			PERCENT OF FULL LOAD (%)						
<u>18,586.96</u>			<u>78.4</u>						
MAJOR EQUIPMENT OUT OF COMMISSION									
<u>BOAT DAVIT, AMR EDUCATOR REMOTE MD-V-5</u>									
EXAMINED DAILY AND CERTIFIED TO BE CORRECT									
SIGNATURE OF ENGINEER OFFICER/RANK					DATE OF SIGNATURE				
<u>Michael Ray Spivey LT, USN</u>					<u>10 AUG 1994</u>				
TIME	RECORD OF ALL EVENTS OF THE DAY						DAY	MONTH	YEAR
							<u>09</u>	<u>AUG</u>	<u>94</u>
	<u>0000 - 0800</u>								
<u>0000</u>	<u>THE SHIP IS MOORED PORTSIDE TO COASTAL SYSTEMS ENGINEERING STATION, PANAMA CITY, FL. THE ENGINEERING PLANT IS IN A COLD IRON STATUS WITH THE FOLLOWING AUXILIARY EQUIPMENT IN OPERATION #14"2 A/C #1 REEFER, #1 MPAC #1 ASW PUMP #14"2 CWP'S &amp; #3 FIP. THE SHIP IS RECEIVING THE FOLLOWING HOTEL SERVICES FROM THE PIER, SHORE POWER, POTABLE WATER, SEWAGE, AND TELEPHONES.</u>								
<u>0445</u>	<u>PRE LUBED AND BAR-OVER 1A &amp; 1B SSDG</u>								
<u>0545</u>	<u>STARTED #2 MPAC.</u>								
<u>0546</u>	<u>STARTED PORT &amp; STBD CPP</u>								
<u>0548</u>	<u>STARTED STBD STANDBY MRC L/O PUMP.</u>								
<u>0549</u>	<u>STARTED PORT STANDBY MRC L/O PUMP.</u>								
CLASSIFICATION							UNCLAS		
(Leave back side blank)							PAGE NO. <u>38</u>		

## **Appendix B: Log Review Summaries**

This appendix provides a summary of the log data reduction used to develop the MCM-1 Class MPDE Duty Cycle. The results for each ship are presented along with the composite results for the class. The data of Table 6 is also provided.

Table B-1: MCM-1 Class Ship Data Summary

	USS ARDENT	USS GLADIATOR	USS WARRIOR
Hull Number	MCM-12	MCM-11	MCM-13
Time Period (1994)	1 May - 31 Oct	1 May - 31 Oct	1 May - 31 Oct
Data Points	4926	6330	3757
Time Covered	211318	221760	161640
Time Secured	191321	187603	139130
Time Running	19997	34157	22510
Time Declutched (Cool Down)	623	1830	965
Time @ Idle	2974	2155	1022
Time @ Power	16400	30172	20523

The Isotta Fraschini engine does not require a warm-up period prior to being clutched to the shaft unless the engine lubricating oil temperature falls below 120 degrees Fahrenheit. Standard operating procedures for all three engineering plants required the oil to be recirculated well before anticipated use. As a result, the engines rarely required a warm-up period. Any time an engine spent warming prior to use was combined with the time the engine spent declutched for cooling prior to stopping or to facilitate testing and training.

The above data points are for steady state operations only. Data points during maneuvering were discarded. Maneuvering was defined, for the purposes of this analysis, as more than one command in a one minute time frame or any split shaft operations lasting less than five minutes. A test was conducted to investigate the sensitivity of the operating profile to this definition.

Figure B-1 is a plot of the time factors for the USS ARDENT (MCM-12) steady state operating profile using the above description verses the time factors for a steady state operating profile based on a definition of maneuvering which was more rigorous. In the more rigorous analysis (dubbed ARDENT<sub>x</sub>), any maneuvers of less than five minutes duration were eliminated. Comparison of the results indicate that frequent, short speed changes had little effect on the steady state operating profile.

Also removed from the steady-state operating profile was time in which the LLPMS were online in place of the MPDEs. The majority of these cases occurred during minehunting operations, in which the speed and course changes were rapid. This is consistent with the final operating profile results which indicated that the MPDEs were primarily used for high speed transit.

The next four sections contain a summary spreadsheet of the time spent at each operating point for each MPDE of each ship. The final section is the composite data for all three ships studied. The following notes are attached to facilitate reading of the data:

- The MCM-1 Class has four MPDE, numbers 1A and 1B on the starboard shaft, and numbers 2A and 2B on the port shaft.

- The time values are given in minutes.

- "n" indicates normalized values. RPM and power are normalized to the engine rated values (1800 RPM and 600 bhp) and time values are normalized to the total running time for a particular engine.



Figure B-1

Figure B-1: Comparison of Results from USS ARDENT and ARDENT (x)

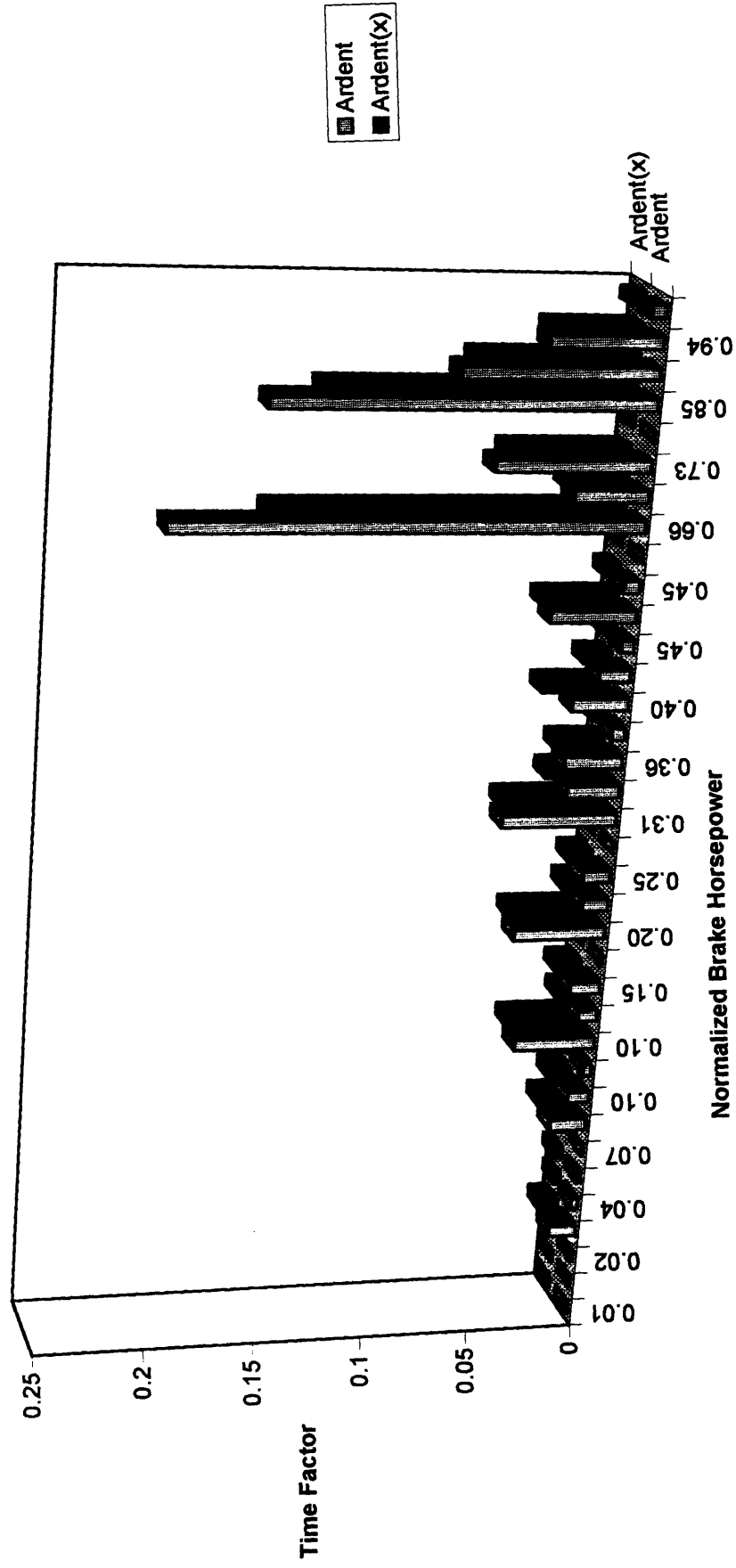


Table B-2: USS GLADIATOR Time Factors Summary

	1A	1B	2A	2B	1A_n	1B_n	2A_n	2B_n	Sum	Eng/shaft	EOT	Speed	RPM	RPM_n	Power	Power_n
Total Time	224640	213120	224640	224640					7322	0.0481	Declutch	0	795.0955	0.44172	0	0
Time Operating	40823	35794	35887	40056				8610	0.0564	idle	2	0.5	795.0955	0.44172	10.2145	0.017024
Time Secured	183817	177326	188753	184584				820	0.0054		1	0.5	795.0955	0.44172	7.148849	0.011915
Time Idle	2291	1731	2284	1834				705	0.0048		1	0.95	795.0955	0.44172	14.73349	0.024556
Time Declutched	1909	1730	1849	1834				838	0.0055		2	1	1.85	795.0955	16.07624	0.026794
Time at Power	36623	32333	31754	35918				1705	0.0112		1	1.4	795.0955	0.44172	23.02206	0.03837
DC	1909	0.0468	1849	0.0515	1834	0.0458	7322	0.0481								
IDLE	2281	0.0561	2284	0.0636	2304	0.0575	8610	0.0564								
0.01	204	0.005	206	0.0057	203	0.0051	820	0.0054								
0.02	165	0.004	290	0.0081	215	0.006	35	0.0009								
0.03	205	0.005	203	0.0057	214	0.006	216	0.0054								
0.04	435	0.0107	398	0.0111	421	0.0117	451	0.0113								
0.05	78	0.0019	78	0.0022	77	0.0021	77	0.0019								
0.07	338	0.0083	337	0.0084	331	0.0092	332	0.0083								
0.08	19	0.0005	27	0.0008	27	0.0008	19	0.0005								
0.09	222	0.0054	161	0.0045	160	0.0045	204	0.0051								
0.10	478	0.0117	474	0.0132	474	0.0132	478	0.0119								
0.13	251	0.0061	251	0.007	248	0.0069	248	0.0062								
0.14	379	0.0093	550	0.0154	573	0.016	361	0.009								
0.16	346	0.0085	345	0.0096	162	0.0045	162	0.004								
0.17	439	0.0108	442	0.0123	463	0.0129	419	0.0105								
0.19	235	0.0058	235	0.0066	213	0.0059	213	0.0053								
0.21	1712	0.0419	1366	0.0382	1476	0.0411	1600	0.0399								
0.22	698	0.0171	705	0.0197	690	0.0182	697	0.0174								
0.26	300	0.0073	363	0.0101	365	0.0102	300	0.0075								
0.32	8	0.0002	7	0.0002	7	0.0002	8	0.0002								
0.33	1287	0.0315	576	0.0161	566	0.0158	1272	0.0318								
0.37	154	0.0038	151	0.0042	151	0.0042	155	0.0039								
0.38	683	0.0167	594	0.0166	660	0.0184	609	0.0152								
0.40	24	0.0006	42	0.0012	43	0.0012	25	0.0006								
0.43	507	0.0124	1088	0.0307	958	0.0287	427	0.0107								
0.44	990	0.0243	984	0.0275	990	0.0276	997	0.0249								
0.52	23	0.0006	23	0.0006	23	0.0006	23	0.0006								
0.61	18792	0.4603	16796	0.5251	18236	0.5082	18232	0.4552								
0.65	376	0.0092	140	0.0039	153	0.0043	369	0.0092								
0.69	1391	0.0341	1391	0.0389	1391	0.0388	1391	0.0347								
0.73	961	0.0235	691	0.0193	840	0.0234	2255	0.0563								
0.78	834	0.0204	800	0.0224	804	0.0224	838	0.0209								
0.83	2821	0.0691	162	0.0045	161	0.0045	2845	0.071								
0.88	208	0.0051	208	0.0058	208	0.0058	208	0.0052								
0.94	41	0.001	29	0.0008	29	0.0008	40	0.001								
0.94	0	0	0	0	0	0	0	0								
0.98	159	0.0039	159	0.0044	159	0.0044	159	0.004								
1.06	860	0.0211	49	0.0014	60	0.0017	50	0.0012								
	40823	1	35794	1	35887	1	40056	1	152560	1						

Figure B2: USS GLADIATOR MPDE Time Factors

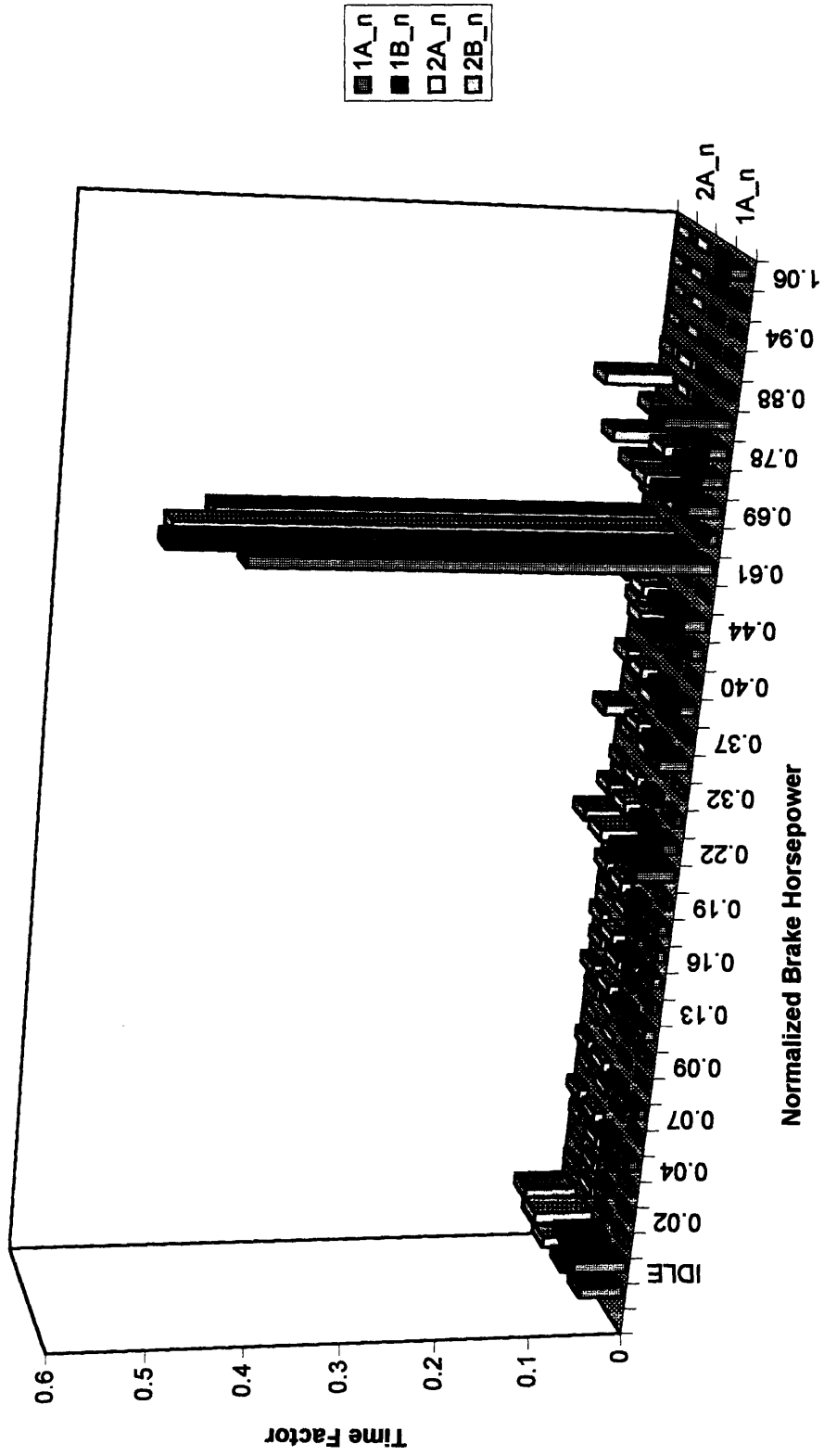


Figure B-3:

Figure B-3: USS GLADIATOR Summary MPDE Composite Operating Profile

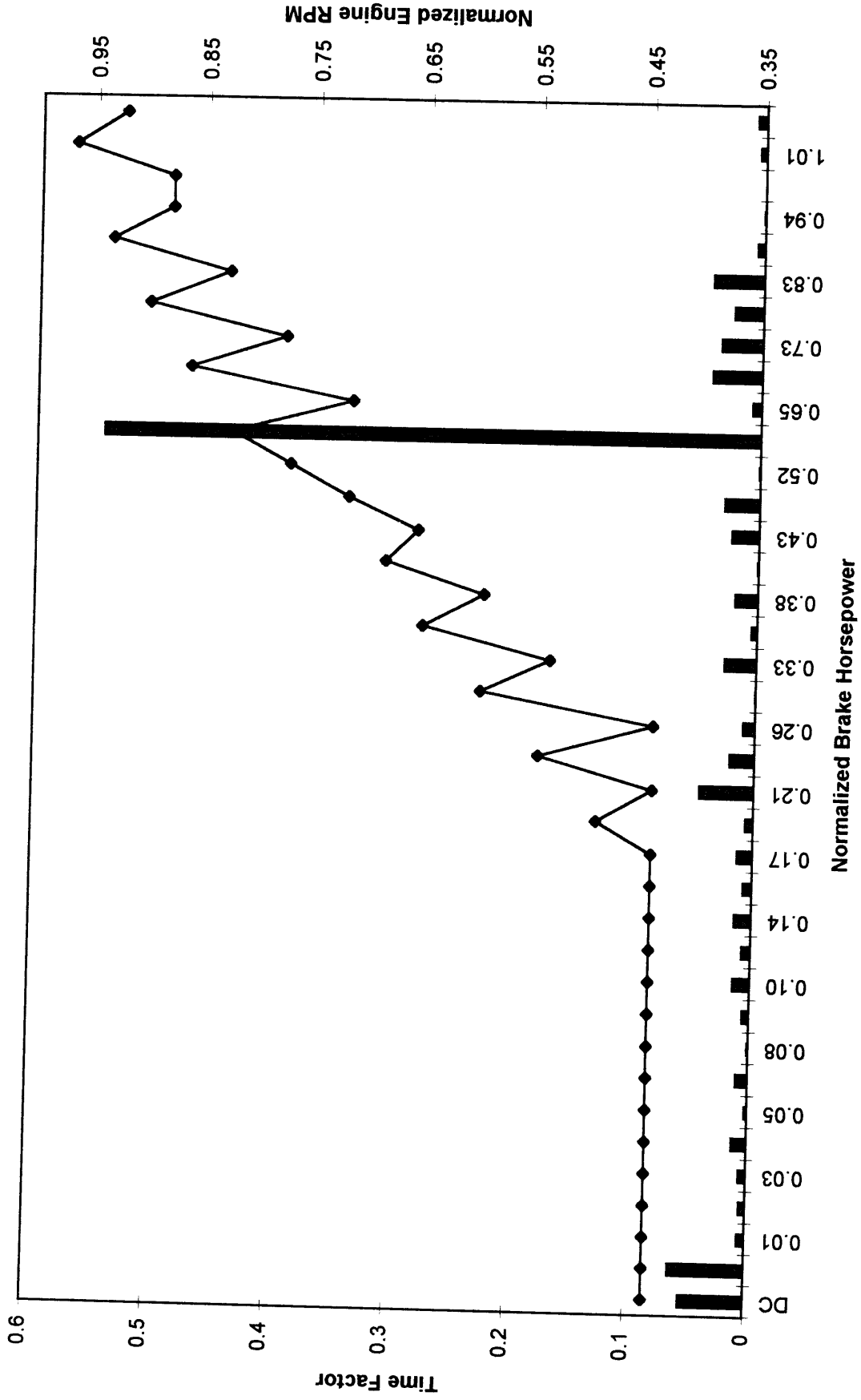


Table B-3: USS ARDENT Time Factor Summary																
	1A	1B	2A	2B	1B_n	2A_n	2B_n	Sums	Eng/shaft	EOT	Speed	RPM	RPM_n	Power	Power_n	
Total Time	215996	221760	191520	215996												
Time Operating	21972	18672	17311	22033												
Time Secured	194024	203088	174209	193963												
Time Idle	3034	2839	2593	3430												
Time Declutched	786	556	504	647												
Time at Power	18152	15277	14214	17956												
	1A	1B	2A	2B	1B_n	2A_n	2B_n	Sums	Eng/shaft	EOT	Speed	RPM	RPM_n	Power	Power_n	
	786	0.03773	556	0.029777	504	0.029114	647	0.029365	0.031007	Declutched	0	795.0955	0.44172	0	DC	
	3034	0.138085	2839	0.152046	2593	0.149789	3430	0.155676	0.148999	Idle	0.5	0.925	795.0955	0.44172	10.2145	IDLE
	0	0	0	0	0	0	0	0	0	0	0.5	0.95	795.0955	0.44172	14.73349	0.024556
	17	0.000774	17	0.00091	17	0.000982	17	0.000772	0.000659	2	1	1.5	795.0955	0.44172	16.07624	0.026794
	102	0.004642	370	0.019816	370	0.021374	107	0.004856	0.012872	1	1	1.5	795.0955	0.44172	23.02206	0.03637
	89	0.004051	89	0.004766	38	0.002195	38	0.001725	0.003164	2	1.5	2.5	795.0955	0.44172	27.06622	0.04516
	45	0.002048	45	0.00241	20	0.001155	20	0.000908	0.00163	2	2	3	795.0955	0.44172	39.26668	0.065444
	15	0.000683	15	0.000803	0	0	0	0	0.000372	2	2.5	4	795.0955	0.44172	49.10357	0.081839
	514	0.023393	150	0.008033	367	0.0212	343	0.015568	0.017049	1	1.5	2.5	795.0955	0.44172	55.45637	0.092427
	237	0.010786	224	0.011997	160	0.009243	160	0.007262	0.008822	2	3	5	795.0955	0.44172	59.8187	0.096966
	69	0.00314	69	0.003695	69	0.003986	69	0.003132	0.003488	2	3.5	5.9	795.0955	0.44172	78.01839	0.130031
	966	0.043965	524	0.028083	746	0.043094	750	0.03404	0.037291	1	2	3	795.0955	0.44172	81.44576	0.135743
	186	0.008465	186	0.009961	156	0.009012	156	0.00708	0.00863	2	4	6.8	795.0955	0.44172	98.29673	0.163828
	258	0.011742	273	0.014621	325	0.018774	215	0.009758	0.013724	1	2.5	4	795.0955	0.44172	101.3898	0.168983
	0	0	0	0	0	0	0	0	0	2	4.5	7.4	844.7437	0.492014	113.7284	0.189547
	1024	0.046605	644	0.03449	714	0.041245	1025	0.046521	0.042215	1	3	5	795.0955	0.44172	123.0902	0.20515
	268	0.012197	268	0.014353	200	0.011553	200	0.009077	0.011795	2	5	8	926.5077	0.545009	130.1785	0.216964
	383	0.017431	135	0.00723	240	0.013884	286	0.012981	0.012876	1	3.5	5.9	795.0955	0.44172	156.0368	0.260061
	0	0	0	0	0	0	0	0	0	2	5.5	8.6	1008.272	0.596004	193.7998	0.323
	1377	0.062671	743	0.039792	827	0.047773	1328	0.060273	0.052627	1	4	6.8	933.2267	0.535739	196.5935	0.327656
	535	0.024349	471	0.025225	436	0.025302	473	0.021468	0.024066	2	6	9.1	1076.408	0.651	219.6696	0.366114
	480	0.021846	584	0.031277	584	0.033736	413	0.018745	0.026401	1	4.5	7.4	1026.537	0.596218	227.4567	0.379095
	107	0.00487	108	0.005784	144	0.008318	114	0.005174	0.006037	2	6.5	9.7	1158.172	0.656996	240.4426	0.400738
	250	0.011378	282	0.015103	298	0.017214	1284	0.058276	0.025493	1	5	8	1119.847	0.656996	260.3571	0.433929
	367	0.017613	367	0.020726	190	0.010976	190	0.008623	0.014485	2	7	10.2	1226.309	0.719137	264.8652	0.441442
	70	0.003166	70	0.003749	146	0.008434	146	0.006626	0.005469	2	7.5	10.8	1308.073	0.772132	310.8133	0.518189
	805	0.036638	805	0.043113	735	0.042459	735	0.033359	0.038892	2	8	11.3	1376.21	0.825127	367.9042	0.613174
	306	0.013927	0	0	180	0.010398	99	0.004493	0.007205	1	5.5	8.6	1213.157	0.717175	387.5965	0.645699
	0	0	0	0	0	0	0	0	0	2	8.5	11.9	1457.974	0.862981	418.0247	0.693375
	6045	0.275123	3340	0.176877	2384	0.136294	5349	0.242772	0.208767	1	6	9.2	1306.467	0.777654	439.3371	0.732229
	785	0.035727	785	0.042042	532	0.030732	532	0.024146	0.033162	2	9	12.5	1539.738	0.900834	470.854	0.784757
	2211	0.100626	595	0.031866	645	0.037726	2362	0.107203	0.069239	1	6.5	9.8	1396.777	0.829493	496.3224	0.827204
	0	0	0	0	0	0	0	0	0	2	9.5	13.1	1621.502	0.934903	526.324	0.87207
	1923	0.08752	4443	0.23795	3296	0.190399	3480	0.157945	0.168454	1	7	10.5	1508.638	0.881332	566.8854	0.944476
	1722	0.076372	1734	0.092866	1734	0.100168	1721	0.07611	0.087379	2	10	13.8	1716.893	0.881332	566.8854	0.979917
	671	0.030539	1202	0.064374	1573	0.090867	309	0.014024	0.048951	1	7.5	11	1586.397	0.968971	587.9469	1.005
	125	0.005699	107	0.005731	166	0.009599	112	0.005083	0.006523	1	8	11.2	1617.5	0.924531	636.7097	1.061183
	21972	1	18672	1	17311	1	22033	1	1	1	11.2	1617.5	0.924531	636.7097	1.061183	

Figure B-4: USS ARDENT MPDE Time Factors

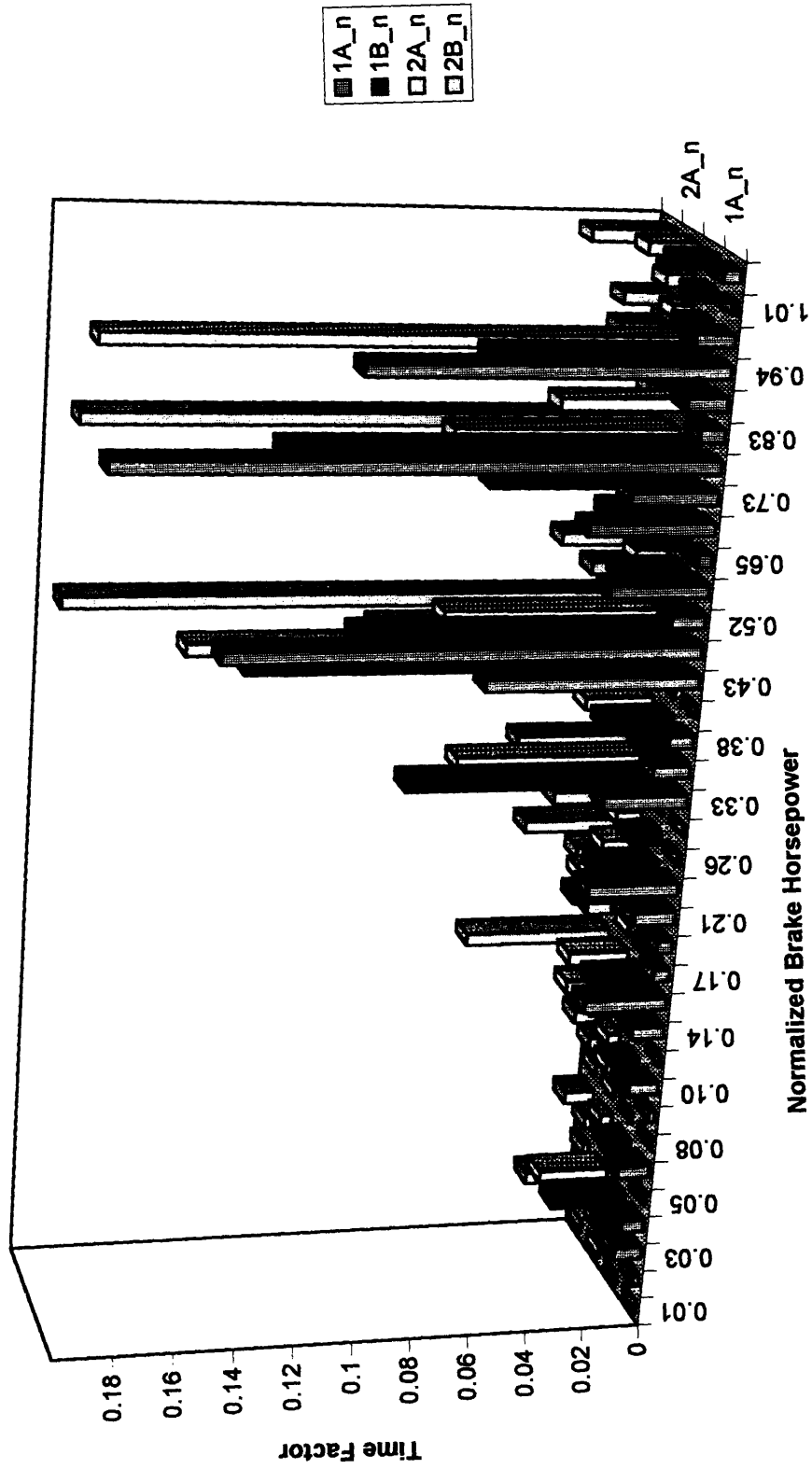


Figure B-5: USS ARDENT Summary MPDE Composite Operating Profile

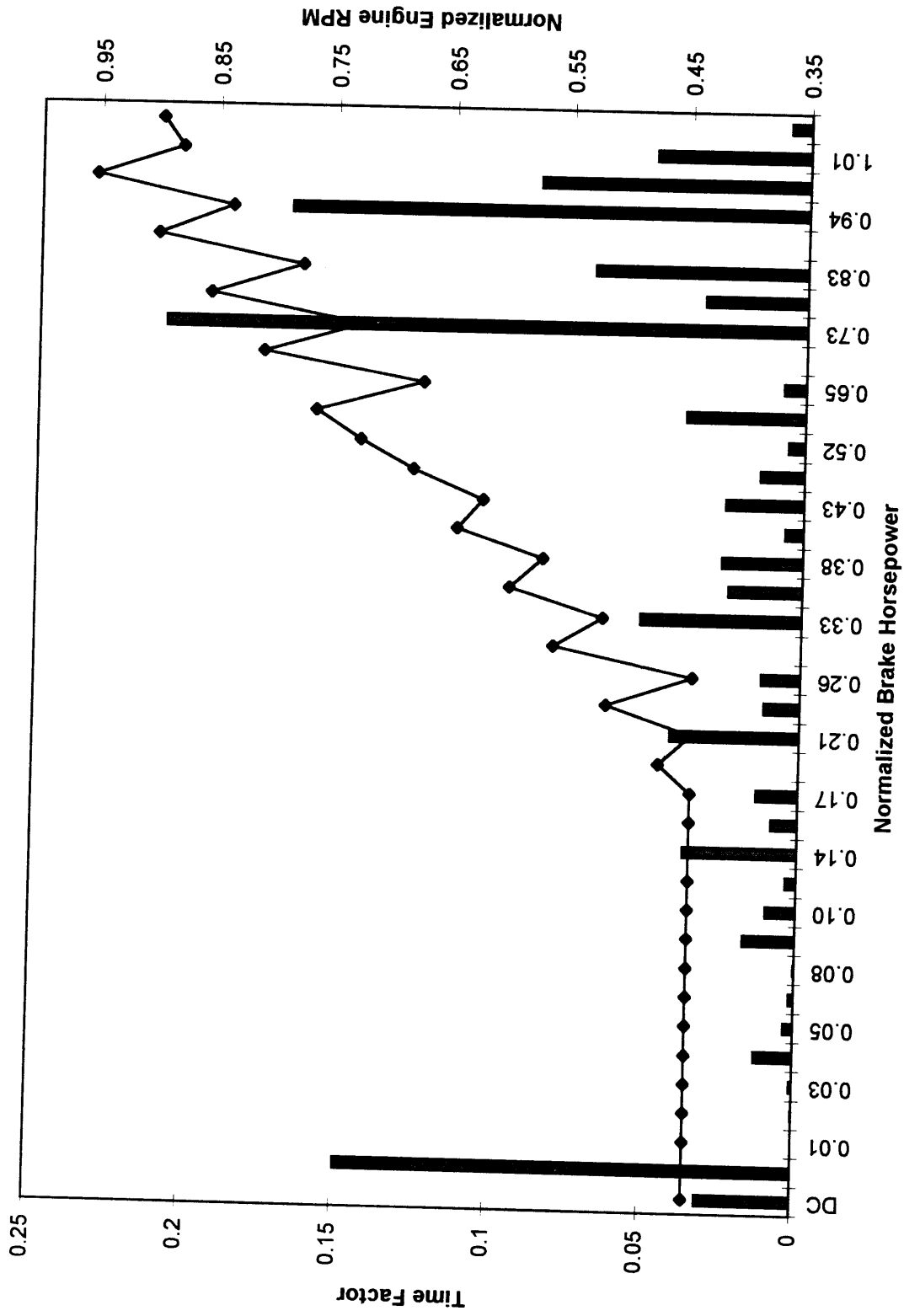


Table B-4: USS WARRIOR Time Factors Summary

	1A	1A_n	1B	1B_n	2A	2A_n	2B	2B_n	Warr	Sum	Eng/shaft	EOT	Speed	RPM	RPM_n	Power	Power_n
Total Time	184320	0	167040	0	178560	0	116640	0	101	0.0016	101	0.0011	0.5	0.95	0.44172	14.73349	0.024556
Time Operating	19094	0	27505	0	31503	0	11939	0	25	0.0021	25	0.0003	0.5	0.925	0.44172	7.148849	0.011915
Time Secured	165226	182	139535	186	147057	265	104701	265	898	0.0222	898	0.0102	1	1.4	0.44172	23.02206	0.03837
Time Idle	1054	40	1097	119	1490	116	448	40	315	0.0037	315	0.0036	1.5	2.85	0.44172	16.07624	0.026794
Time Declatched	1087	29	1095	29	1188	29	660	29	116	0.0024	116	0.0013	1.5	2.8	0.44172	55.45637	0.092427
Time at Power	163085	210	137513	511	144379	653	103593	81	1455	0.0088	1455	0.0165	2	3.8	0.44172	27.09622	0.04516
		211		240		125		125	701	0.0079	701	0.0079	2	3.7	0.44172	39.26668	0.065444
		105		26		105		105	262	0.003	262	0.003	1	4.4	0.44172	101.3888	0.168983
		4		4		4		4	16	0.0003	16	0.0002	2	4.4	0.44172	49.10357	0.081839
		267		776		626		170	1839	0.0208	1839	0.0208	1	5.1	0.44172	123.0902	0.20515
		191		225		133		115	684	0.0075	684	0.0075	2	5	0.44172	59.8187	0.099698
		22		269		272		288	851	0.0096	851	0.0096	1	6	0.44172	156.0369	0.260061
		5		5		16		16	42	0.0005	42	0.0005	2	6	0.44172	78.01839	0.130031
		541		2434		2067		461	5503	0.0624	5503	0.0624	1	7	0.44172	196.5935	0.327656
		536		517		651		606	2310	0.0262	2310	0.0262	2	7	0.44172	98.29673	0.163828
		153		644		725		27	1549	0.0176	1549	0.0176	1	4.5	0.44172	227.4567	0.378095
		99		99		98		98	394	0.0045	394	0.0045	2	4.5	0.44172	113.7284	0.186547
		1353		3952		4985		1086	11376	0.1289	11376	0.1289	1	5	0.44172	260.3571	0.433929
		587		593		399		399	1978	0.0224	1978	0.0224	2	5	0.44172	130.1765	0.216964
		89		469		652		89	1297	0.0147	1297	0.0147	1	5.5	0.44172	387.5995	0.645999
		0		0		0		0	0	0	0	0	2	5.5	0.44172	183.7998	0.323
		549		1879		2301		419	5148	0.0583	5148	0.0583	1	6	0.44172	439.3371	0.732229
		238		240		123		120	721	0.0082	721	0.0082	2	6	0.44172	219.6686	0.368114
		155		19		1283		50	1507	0.0171	1507	0.0171	1	6.5	0.44172	498.3224	0.827204
		2		2		0		0	4	5E-05	4	5E-05	2	6.5	0.44172	240.4426	0.400738
		2235		1979		6015		195	10424	0.1181	10424	0.1181	1	7	0.44172	568.6854	0.944478
		2983		2987		2331		2331	10632	0.1205	10632	0.1205	2	7	0.44172	264.8652	0.441442
		23		202		299		1	548	0.0062	548	0.0062	1	7.5	0.44172	566.6854	0.944478
		216		216		216		216	864	0.0098	864	0.0098	2	7.5	0.44172	310.9133	0.518189
		108		377		511		341	1337	0.0152	1337	0.0152	1	8	0.44172	636.7097	1.061183
		625		627		332		350	1934	0.0219	1934	0.0219	2	8	0.44172	367.9042	0.613174
		795		795		11		11	1612	0.0183	1612	0.0183	2	8.5	0.44172	416.0247	0.693375
		3710		3738		2372		2290	12108	0.1372	12108	0.1372	2	9	0.44172	470.854	0.784757
		256		256		167		187	896	0.01	896	0.01	2	9.5	0.44172	587.9489	0.979917
		244		244		191		190	869	0.0098	869	0.0098	2	10	0.44172	587.9489	0.979917
		1087		925		1188		660	3860	0.0437	3860	0.0437	2	10	0.44172	587.9489	0.979917
		1054		1052		1490		448	4089	0.0463	4089	0.0463	2	10	0.44172	587.9489	0.979917
		18094		27505		31503		11939	88235	0.0463	88235	0.0463	2	10	0.44172	10.2145	0.017024



Figure B-6: USS WARRIOR MPDE Time Factors

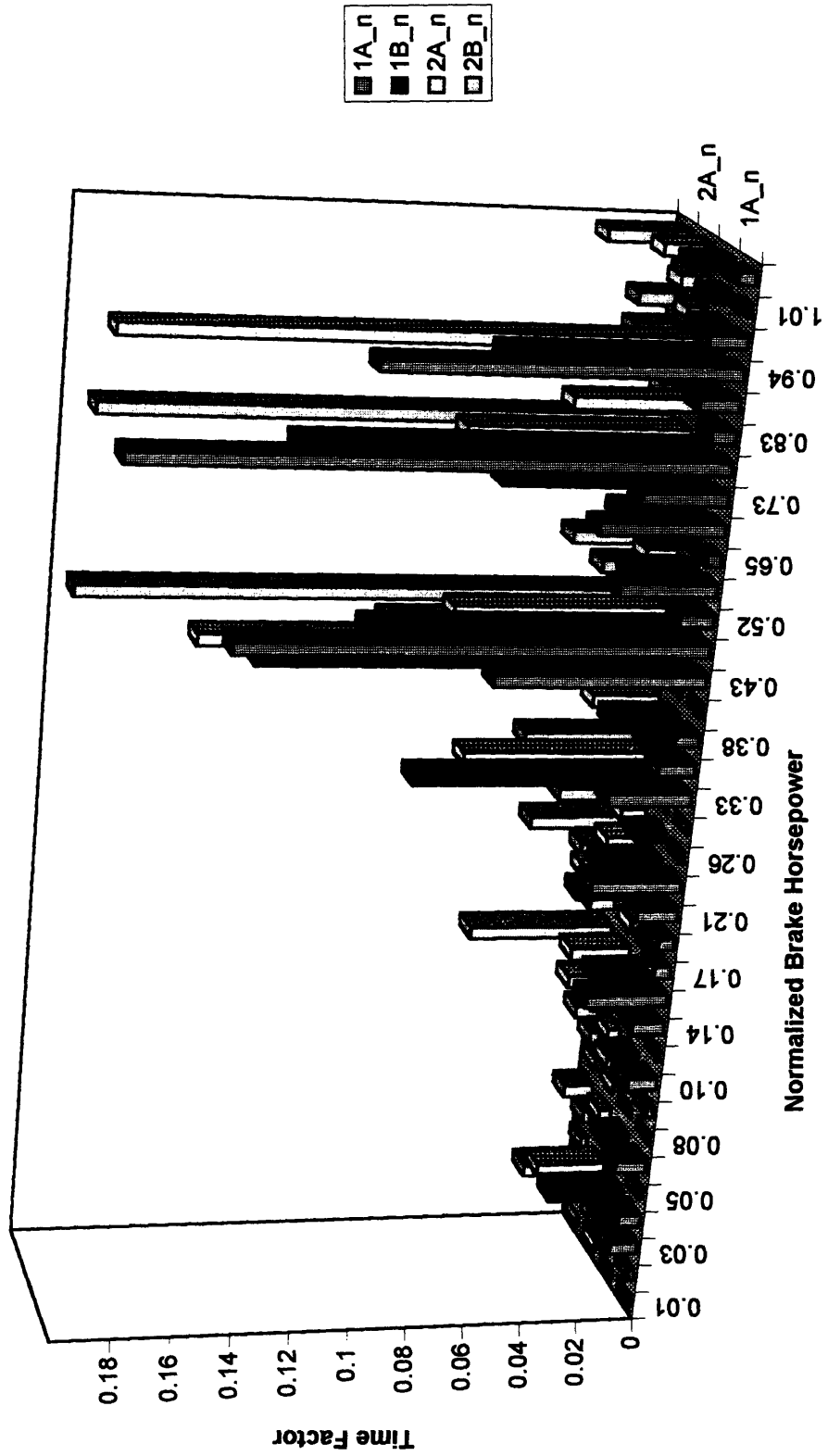


Figure B-7: USS WARRIOR Summary MPDE Composite Operating Profile

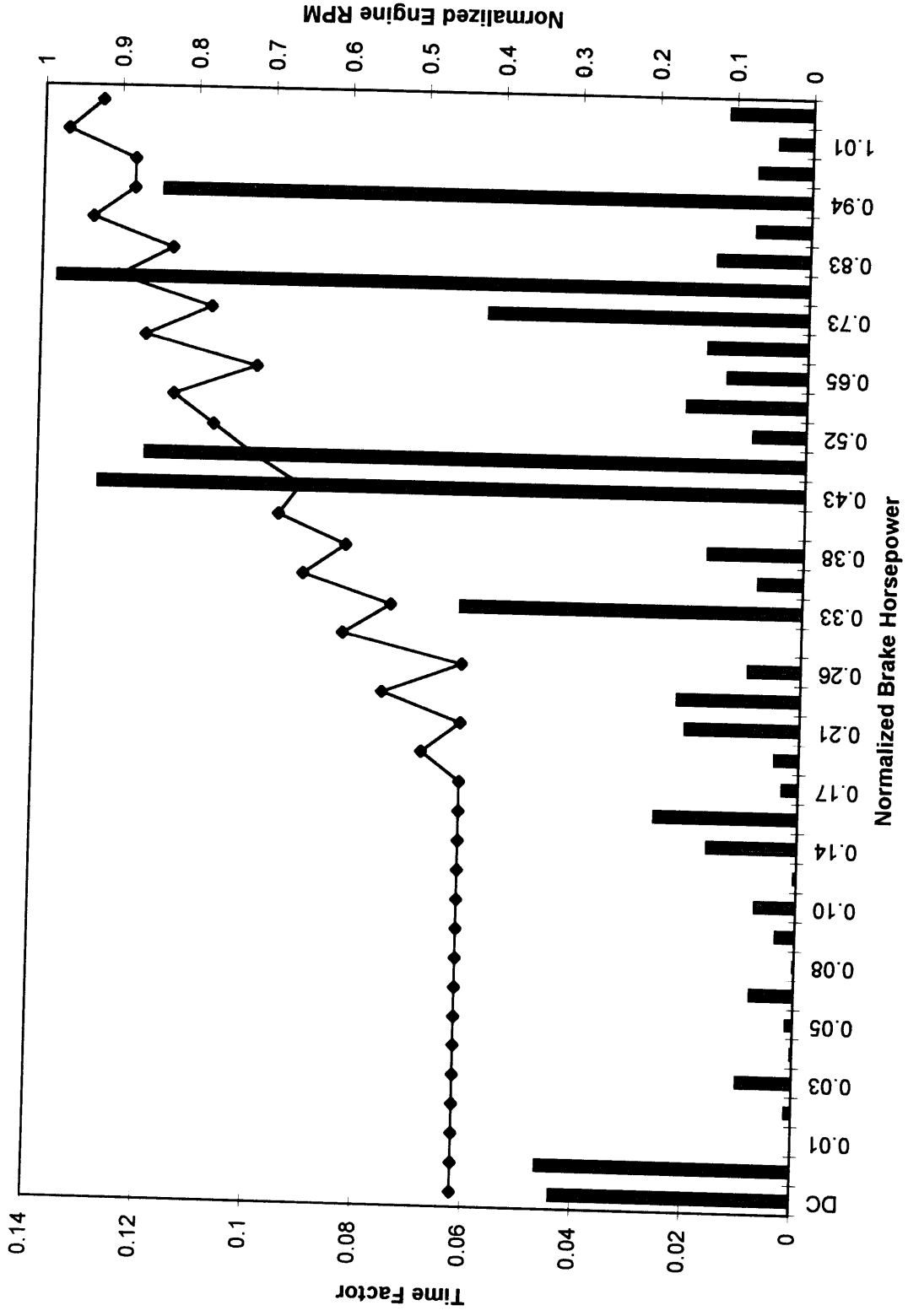


Table B-5: Composite Time Factor Calculations

	ARDENT	ARDENT_n	GLADIATOR	GLAD_n	WARRIOR	WAR_n	Total	Total_n	EnginesShaft	EOT	Speed	RPM	RPM_n	Power	Power_n
Data Points	4926	6330			3757		15013								
Total Time	211318	221760			161840		594718								
Time Operating	19997	34157			22510		76664								
Time Secured	191321	187603			139130		518054								
Time Idle	2974	2155			1022		6151								
Time Declothed	623	1830			965		3418								
Time at Power	16400	30172			20523		67095								
	2493	0.031	7322	0.048	3660	0.044	13675	0.044		Decloth	0	795.0955	0.44171972	10.2145	0 DC
	11896	0.149	8610	0.056	4089	0.046	24595	0.088	Idle	0.5	0.925	795.0955	0.44171972	10.2145	IDLE
	0	0.000	820	0.005	0	0.000	820	0.002		0.5	0.925	795.0955	0.44171972	10.2145	0.012
	14	0.000	705	0.005	101	0.001	820	0.002		0.5	0.95	795.0955	0.44172	14.73349	0.025
	949	0.013	1705	0.011	25	0.000	2679	0.008		1	1.4	795.0955	0.44172	23.02206	0.038
	68	0.001	838	0.006	898	0.010	1804	0.006		1	1.85	795.0955	0.44172	16.07624	0.027
	254	0.003	310	0.002	116	0.001	680	0.002		1.5	2.8	795.0955	0.44172	27.09622	0.045
	1374	0.017	747	0.005	315	0.004	2436	0.009		1.5	2.85	795.0955	0.44172	55.45637	0.092
	130	0.002	1338	0.009	701	0.008	2169	0.007		2	3.7	795.0955	0.44172	39.26668	0.065
	2986	0.037	1863	0.012	1455	0.016	6304	0.023		2	3.8	795.0955	0.44172	81.44576	0.136
	30	0.000	92	0.001	16	0.000	138	0.000		2.5	4.4	795.0955	0.44172	48.10357	0.082
	1071	0.014	1763	0.012	262	0.003	3096	0.010		2.5	4.4	795.0955	0.44172	101.3896	0.169
	781	0.010	1904	0.013	664	0.008	3349	0.011		3	5	795.0955	0.44172	59.8187	0.100
	3407	0.042	6154	0.040	1839	0.021	11400	0.037		3	5.1	795.0955	0.44172	123.0902	0.205
	276	0.003	998	0.007	42	0.000	1316	0.004		3.5	6	795.0955	0.44172	78.01839	0.130
	1044	0.013	1328	0.009	851	0.010	3223	0.011		3.5	6	808.8134	0.44172	166.0368	0.260
	884	0.009	1015	0.007	2310	0.026	4009	0.015		4	7	795.0955	0.44171972	96.29673	0.164
	4275	0.053	3701	0.024	5603	0.062	13479	0.049		4	7	964.3301	0.53573894	196.5935	0.328
	0	0.000	896	0.006	394	0.004	1290	0.004		4.5	7.7	885.6257	0.49201428	113.7284	0.190
	2061	0.026	2546	0.017	1549	0.018	6156	0.021		4.5	7.7	1073.192	0.59621778	227.4567	0.379
	936	0.012	2791	0.018	1978	0.022	5705	0.019		5	8.4	981.017	0.54500944	130.1785	0.217
	2114	0.025	2990	0.020	11376	0.129	16480	0.063		5	8.4	1182.053	0.65669611	260.3571	0.434
	0	0.000	30	0.000	0	0.000	30	0.000		5.5	9.1	1076.408	0.59800444	193.7998	0.323
	585	0.007	1038	0.007	1297	0.015	2920	0.010		5.5	9.1	1290.915	0.717175	387.5995	0.646
	1917	0.024	611	0.004	721	0.008	3249	0.013		6	9.8	1171.8	0.651	219.6686	0.366
	17128	0.209	4747	0.031	5146	0.058	27023	0.102		6	9.8	1399.777	0.77765389	439.3371	0.732
	473	0.006	134	0.001	4	0.000	611	0.002		6.5	10.25	1233.123	0.68506833	240.4426	0.401
	5813	0.069	5989	0.037	1507	0.017	13309	0.043		6.5	10.4	1493.087	0.82949278	496.3224	0.827
	1154	0.014	3961	0.026	10632	0.120	15747	0.059		7	10.7	1294.446	0.71913667	264.8652	0.441
	13142	0.168	139	0.001	10424	0.118	23705	0.100		7	11	1586.397	0.88133167	566.6854	0.944
	6911	0.087	0	0.000	869	0.010	7780	0.033		7.5	11.25	1586.397	0.88133167	566.6854	1.005
	432	0.005	92	0.001	864	0.010	1388	0.006		7.5	11.4	1389.837	0.77213167	310.9133	0.518
	510	0.007	1019	0.006	1337	0.015	2866	0.010		8	11.5	1664.155	0.92453056	636.7097	1.061
	3080	0.039	74056	0.487	1934	0.022	79070	0.202		8	12.1	1485.228	0.82512667	367.9042	0.613
	0	0.000	5564	0.037	1612	0.018	7176	0.020		8.5	12.6	1553.365	0.86298056	416.0247	0.693
	2634	0.033	3276	0.022	12108	0.137	18018	0.069		9	13.1	1621.502	0.90063444	470.854	0.785
	0	0.000	832	0.005	886	0.010	1718	0.006		9.5	13.55	1622.825	0.93490278	526.324	0.877
	3755	0.050	636	0.004	548	0.006	4939	0.020		10	14	1744.148	0.96897111	587.9498	0.980

Figure B-8: Comparison Plot of MCM-1 Class MPDE Operating Profiles

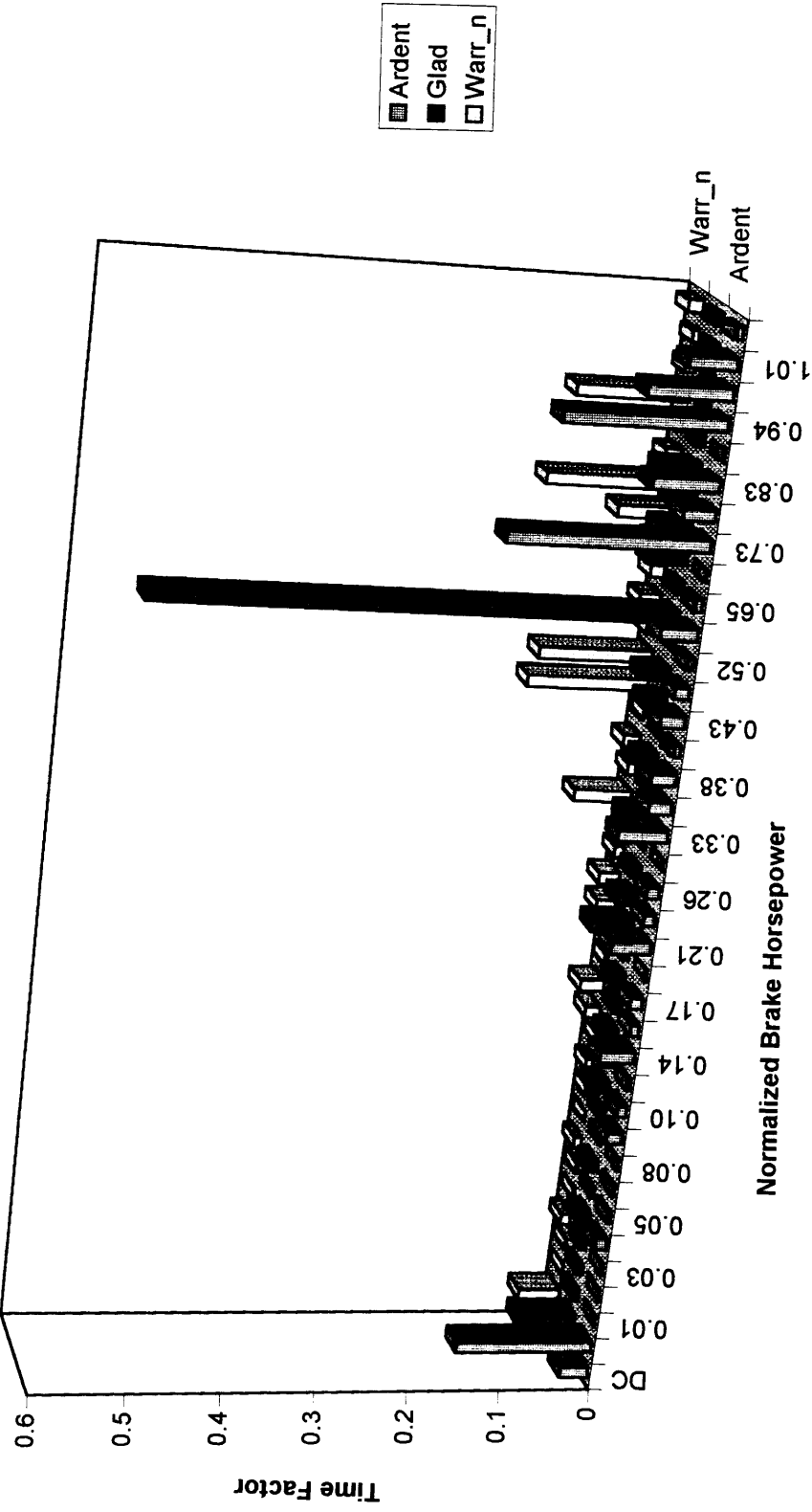
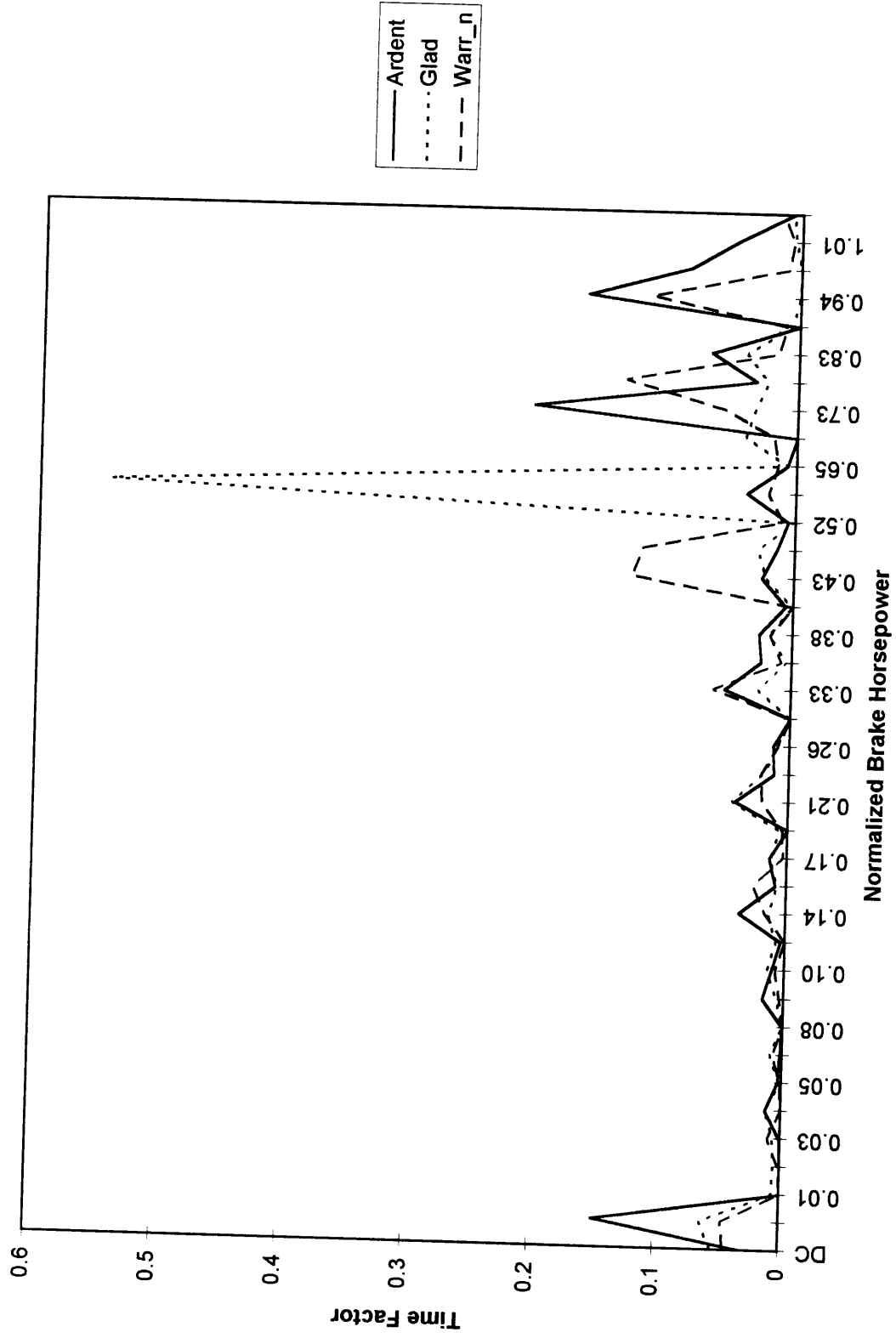


Figure B-9: Comparison Plot of MCM-1 Class MPDE Time Factors



## **Appendix C: MPDE and SSDG Emission Prediction Data**

Included in this appendix are the plots upon which the duty cycle emissions estimations were based. The emission contour plots upon which each duty cycle data point were superimposed in for the Colt-Pielstick PA4-200-VGA high speed diesel engine. This data was found in the August 1992 issue of *The Motor Ship* and was normalized using the Power Fraction and RPM Fraction introduced in equations (9) and (10) of Chapter 3.

Table C-1 is the emission prediction spreadsheet based on linear interpolation of the emission contour maps of Figures C-1 through C-11.

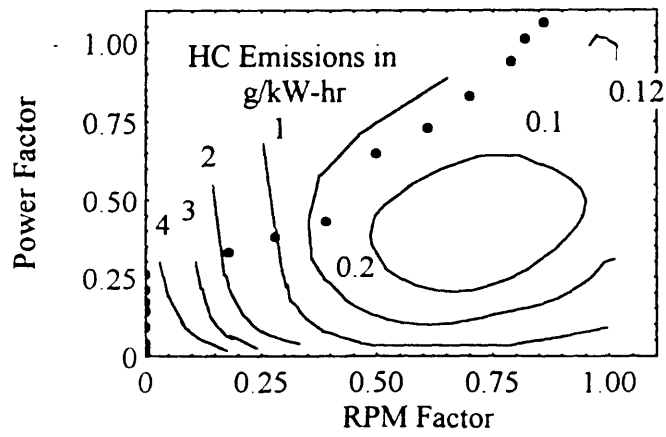
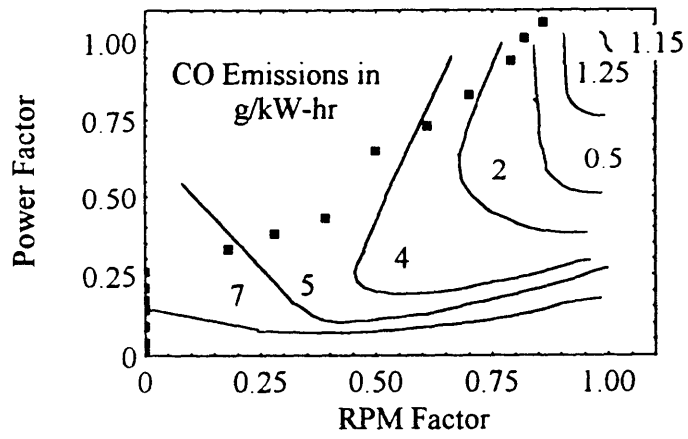
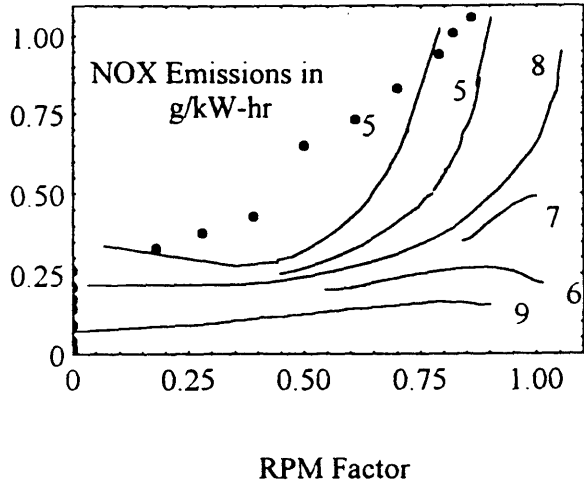
Table C-1: Duty Cycle Comparison and Emissions Prediction											
	RPM Factor	Power Factor	Time Factor	NOx	NOx Time	CO	CO Time	HC	HC Time		
ISO 8178 Duty Cycle E3	0.63	0.25	0.15	7	1.05	3.7	0.555	0.09	0.0135		
	0.8	0.5	0.15	52	0.78	1.5	0.225	0.07	0.0105		
	0.91	0.75	0.5	5.5	2.75	1	0.5	0.11	0.055		
	1	1	0.2	7.1	1.42	1.15	0.23	0.12	0.024		
	Total			1	6		1.51	0.12	0.103		
ICOMIA Marine Engine Duty Cycle	0	0	0.4	9.5	3.8	8	3.2	6	2.4		
	0.4	0.253	0.25	5	1.25	4.4	1.1	0.2	0.05		
	0.6	0.465	0.15	4.9	0.735	3	0.45	0.07	0.0105		
	0.8	0.716	0.14	5.3	0.742	0.9	0.126	0.11	0.0154		
	Total	1	1	0.06	7	0.42	1.15	0.069	0.12	0.0072	
CARB 8-Mode Duty Cycle	0	0	0.05	9.5	0.475	8	0.4	6	0.3		
	1	0.75	0.15	7.8	1.17	1.25	0.1875	0.11	0.0165		
	1	0.5	0.15	7	1.05	0.75	0.075	0.11	0.0165		
	0	0	0.05	9.5	0.475	8	0.4	6	0.3		
	Total	0.85	1	0.15	5.3	0.795	0.5	0.075	0.12	0.018	
MCM-1 MPDE Duty Cycle	0.85	0.75	0.15	5	0.75	0.5	0.075	0.1	0.015		
	0.85	0.5	0.15	7	1.05	1.2	0.18	0.08	0.012		
	0.85	0.3	0.15	6.5	0.975	3.4	0.51	0.1	0.015		
	Total			1	6.74		1.9025		0.693		
		0.00	0.00	0.12	9.5	1.168633	8	0.984112	6	0.738084	
ISO 8178 Duty Cycle E5	0.00	0.21	0.03	9.1	0.2823548	7.7	0.2389156	5.6	0.1737568		
	0.00	0.10	0.01	8.6	0.1108196	7.3	0.0940678	5.1	0.0657186		
	0.00	0.16	0.02	8	0.146704	6.8	0.1246984	4.5	0.082521		
	0.17	0.33	0.05	5	0.232975	5.2	0.242294	2	0.09319		
	Total	0.39	0.43	0.05	4.5	0.241587	4.5	0.241587	0.18	0.00966348	
ISO 8178 Duty Cycle E5	0.44	0.40	0.30	4.6	1.4019696	4.2	1.2800592	0.15	0.0457164		
	0.59	0.52	0.08	4.8	0.3887184	3.3	0.2672439	0.09	0.00728847		
	0.60	0.73	0.07	4.4	0.320144	4	0.29104	0.17	0.0123692		
	0.75	0.69	0.10	5.1	0.5161404	1.5	0.151806	0.12	0.01214448		
	Total	0.79	1.01	0.13	5	0.64821	2	0.259284	0.2	0.0259284	
ISO 8178 Duty Cycle E5	0.88	0.88	0.03	5	0.12544	0.9	0.0225792	0.11	0.00275968		
			1.00		5.58		4.20		1.27		
	0	0	0.30	9.5	2.85	8	2.40	6	1.80		
	0.8	0.5	0.17	5	0.85	1.5	0.26	0.07	0.01		
	Total	0.83	0.25	0.32	6	1.92	4	1.28	0.11	0.04	
ISO 8178 Duty Cycle E5	0.91	0.75	0.13	5.8	0.75	1	0.13	0.11	0.01		
	1	1	0.08	7	0.56	1.15	0.09	0.12	0.01		
	Total			1.00	6.93		4.16		1.87		

	RPM Factor	Power Factor	Time Factor	NOx	NOx Time	CO	CO Time	HC	HC Time
MCM-1 MPDE Propeller Curve	0	0	0.114	9.5	1.08471173	8	0.913441457	6	0.685081093
1 Engine Per Shaft	0	0.02	0.002	9	0.022018546	7.8	0.01908274	5.7	0.013945079
	0	0.04	0.005	8.5	0.045749645	7.5	0.040367334	5.4	0.02906448
	0	0.09	0.002	8	0.016230473	7.3	0.014810306	5.1	0.010346926
	0	0.14	0.000	7.5	0.003087967	7.1	0.002923275	4.8	0.001916289
	0	0.17	0.010	7	0.069943193	6.9	0.068944005	4.6	0.04596267
	0	0.21	0.019	6.5	0.122253649	6.7	0.1260153	4.4	0.082756316
	0	0.26	0.009	5.5	0.050803766	6.5	0.060040815	4.2	0.038795603
	0.17	0.33	0.034	4.9	0.1666607	5.1	0.173463177	1.9	0.064623537
	0.28	0.38	0.010	4.7	0.045195004	4.8	0.0461566	1	0.009615958
	0.39	0.43	0.040	4.5	0.180968279	4.5	0.180968279	0.17	0.006836579
	0.49	0.65	0.018	4.2	0.077140095	4.2	0.077140095	0.17	0.003122337
	0.6	0.73	0.049	4.7	0.231093289	3.9	0.191758261	0.17	0.008358693
	0.69	0.83	0.004	4.8	0.019877555	2.1	0.00696643	0.17	0.000703997
	0.79	0.94	0.009	5.1	0.044430919	1.2	0.010454334	0.2	0.001742389
	0.83	1.01	0.081	5.2	0.419246238	0.6	0.048374566	0.2	0.016124855
	0.86	1.06	0.040	5.3	0.210452245	0.8	0.031766377	0.2	0.007941594
			0.447		2.81		2.01		1.03
MCM-1 MPDE Propeller Curve	0	0.01	0.002	9.4	0.022997148	7.9	0.01932739	5.9	0.01443438
2 Engines per Shaft	0	0.03	0.008	9.2	0.073534782	7.8	0.062344707	5.7	0.045559593
	0	0.05	0.006	9	0.058241739	7.7	0.049829043	5.6	0.036239304
	0	0.07	0.007	8.9	0.064684401	7.6	0.055236118	5.4	0.039246715
	0	0.08	0.004	8.7	0.034159178	7.5	0.029447567	5.3	0.020609614
	0	0.1	0.012	8.7	0.1040609	7.3	0.087315468	5.1	0.061001217
	0	0.13	0.004	8.3	0.031944793	7.2	0.027711145	4.9	0.018858974
	0	0.16	0.017	8.1	0.137871004	7	0.119147781	4.8	0.081701335
	0.09	0.19	0.000	8	0.00071605	6.9	0.000581791	3.5	0.000313272
	0.19	0.22	0.010	7	0.067854713	6.5	0.047498299	1.9	0.033927357
	0.28	0.32	0.002	5	0.009114723	4.9	0.008203251	1.1	0.003463595
	0.37	0.37	0.047	4.5	0.211418317	4.5	0.202021947	0.19	0.051680033
	0.44	0.4	0.236	4.5	1.061589274	4.3	0.94363491	0.15	0.044822658
	0.5	0.44	0.021	4.5	0.096344563	4	0.064229709	0.1	0.003211485
	0.59	0.52	0.054	4.7	0.252660127	3	0.107514948	0.09	0.005375747
	0.69	0.61	0.005	5	0.025628632	2	0.007176017	0.1	0.000461315
	0.75	0.69	0.071	5.1	0.360696996	1.4	0.042434929	0.11	0.007072488
	0.82	0.78	0.023	5.1	0.11838101	0.6	0.01858957	0.1	0.002553316
	0.88	0.88	0.015	5	0.073678589	0.8	0.017682861	0.11	0.001473572
	0.94	0.98	0.009	5.5	0.047029585	1.2	0.010517525	0.12	0.000940592
			0.553		2.85	1.23	1.92		0.47

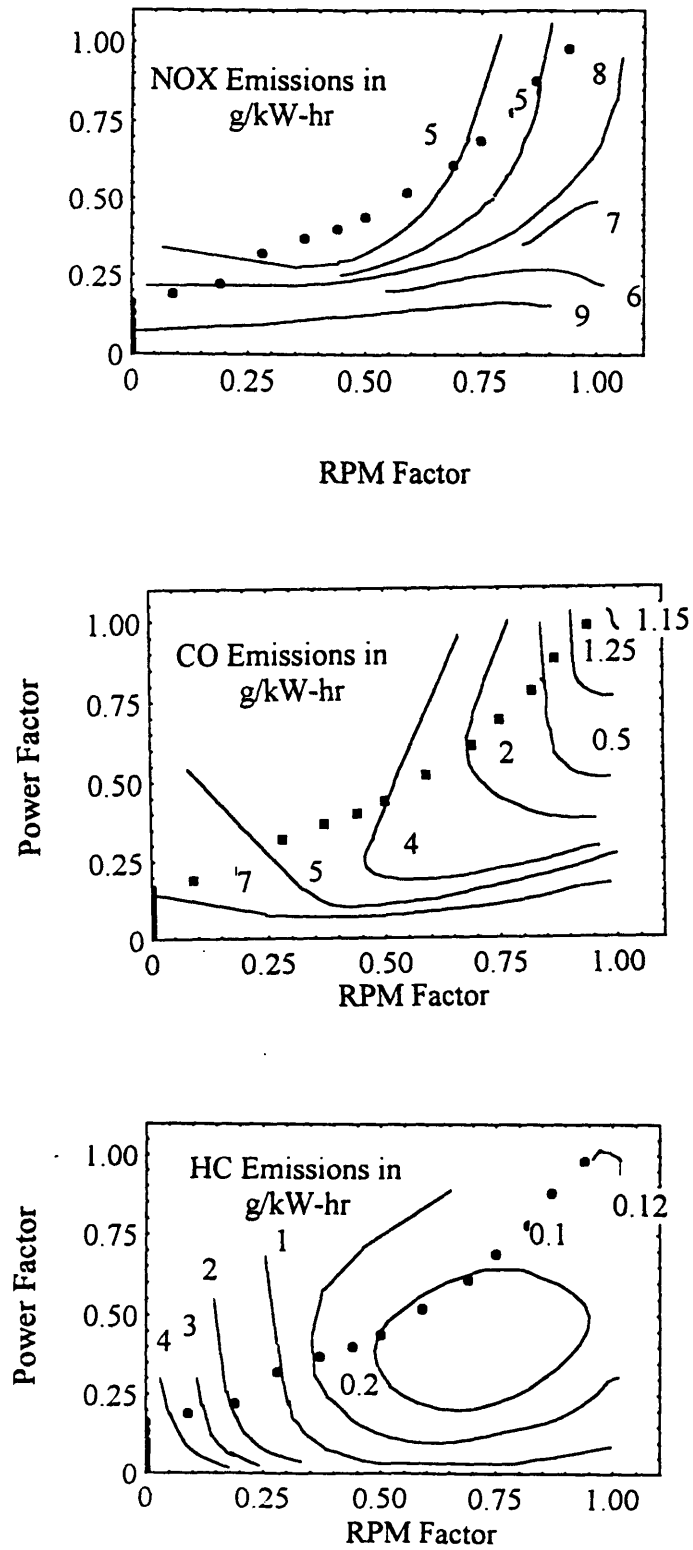


	RPM Factor	Power Factor	Time Factor	NOx	NOx Time	CO	CO Time	HC	HC Time
MCM-1 Class SSDG Duty Cycle	1	0	0.07	11	0.77	9	0.63	2	0.14
	1	0.3	0.21	6.2	1.30	4	0.84	0.2	0.04
	1	0.35	0.21	6.4	1.34	3	0.63	0.18	0.04
	1	0.4	0.19	6.6	1.25	1.6	0.30	0.16	0.03
	1	0.45	0.2	6.8	1.36	1	0.20	0.15	0.03
	1	0.5	0.12	7	0.94	0.5	0.06	0.14	0.02
	1	1	1	6.87	2.66	0.30			
ISO 8178 Duty Cycle C-1	0	0	0.15	11	1.65	9.00	1.35	2.00	0.30
	0.6	0.5	0.1	4.9	0.49	3.00	0.30	0.08	0.01
	0.6	0.75	0.1	4.5	0.45	4.00	0.40	0.18	0.02
	0.6	1	0.1	4.3	0.43	4.20	0.42	0.30	0.03
	1	0.1	0.1	9	0.90	8.00	0.80	1.00	0.10
	1	0.5	0.15	7	1.05	0.50	0.08	0.15	0.02
	1	0.75	0.15	8	1.20	1.25	0.19	0.11	0.02
ISO 8178 Duty Cycle D-2	1	1	0.15	7	1.05	1.15	0.17	0.12	0.02
	1	1	1	7.22	3.71	0.51			
	1	0.1	0.1	9	0.90	8.00	0.80	1.00	0.10
	1	0.25	0.3	6	1.60	5.00	1.50	0.30	0.09
	1	0.5	0.3	7	2.10	0.50	0.15	0.15	0.05
	1	0.75	0.25	8	2.00	1.25	0.31	0.11	0.03
	1	1	0.05	7	0.35	1.15	0.06	0.12	0.01
SSDG Operating Points	1	1	1	7.15	2.82	0.27			
	1	0	0.05	11	0.56	9	0.46	2	0.10
	1	0.2	0.00	6.5	0.03	6.8	0.03	0.4	0.00
	1	0.25	0.04	6.1	0.25	5.3	0.22	0.3	0.01
	1	0.3	0.19	6.2	1.16	4	0.75	0.2	0.04
	1	0.35	0.18	6.4	1.16	3	0.55	0.18	0.03
	1	0.4	0.16	6.6	1.06	1.6	0.26	0.16	0.03
	1	0.45	0.17	6.8	1.15	1	0.17	0.15	0.03
	1	0.5	0.11	7	0.76	0.5	0.05	0.14	0.02
	1	0.55	0.07	7.4	0.50	0.6	0.04	0.14	0.01
	1	0.6	0.02	7.8	0.15	0.7	0.01	0.13	0.00
	1	0.65	0.01	8	0.06	0.9	0.01	0.12	0.00
	1	0.7	0.00	7.8	0.01	1.1	0.00	0.12	0.00
	1.00	1.00	6.86	2.54	0.26				

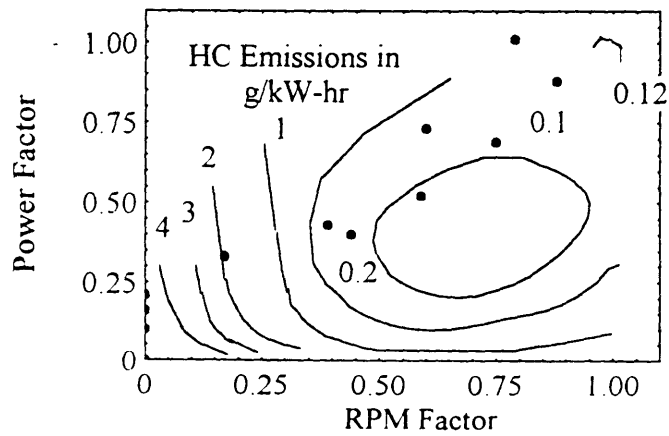
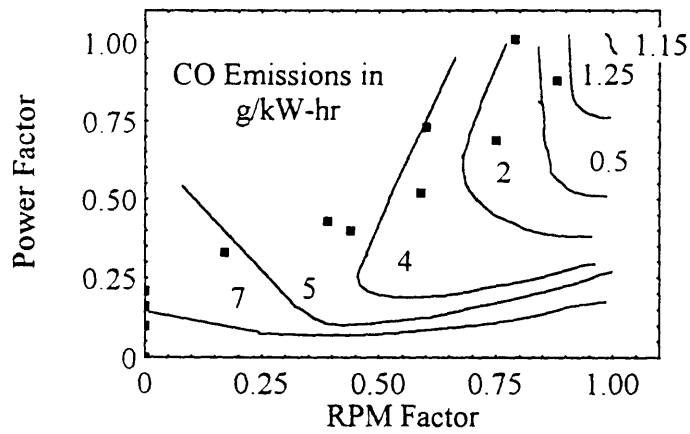
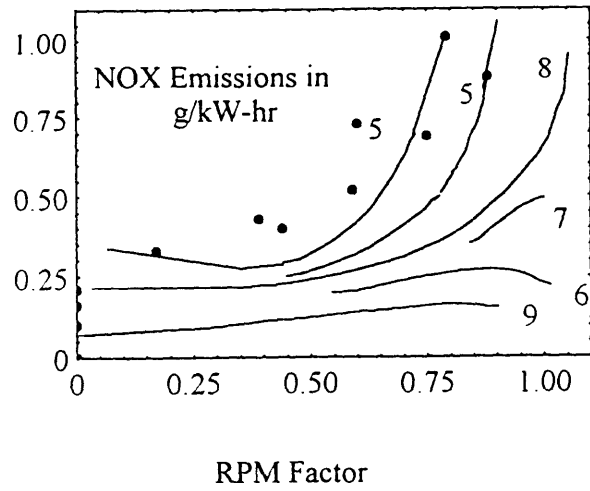
**Figure C-1: MCM-1 Operating Profile (One Engine Per Shaft)**



**Figure C-2: MCM-1 Operating Profile (Two Engines per Shaft)**



**Figure C-3: MCM-1 MPDE Duty Cycle**



**Figure C-4: ISO 8178 Duty Cycle E-5**

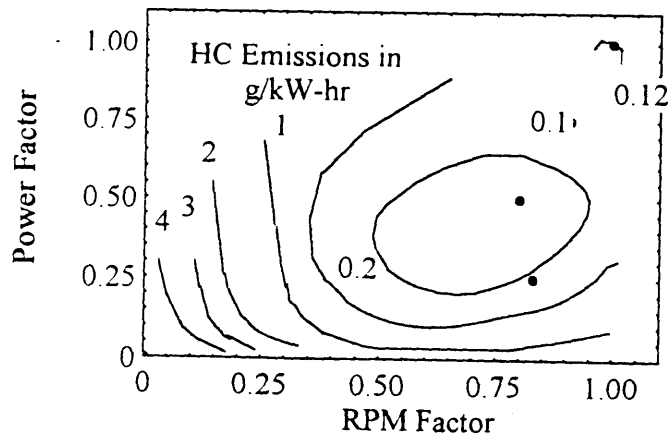
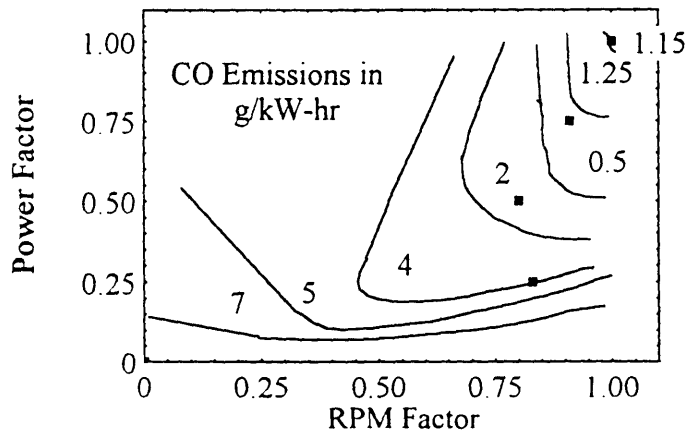
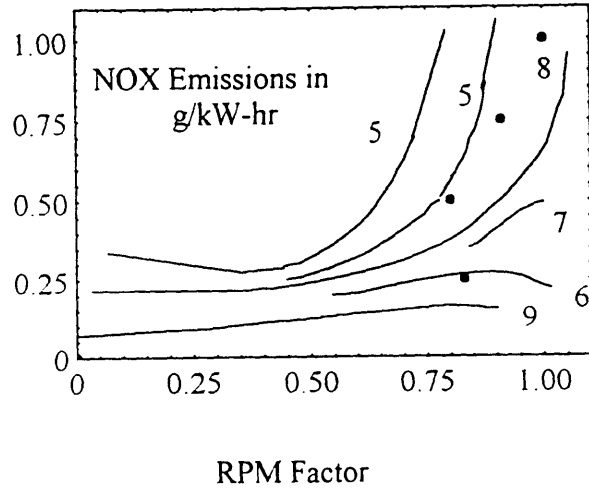
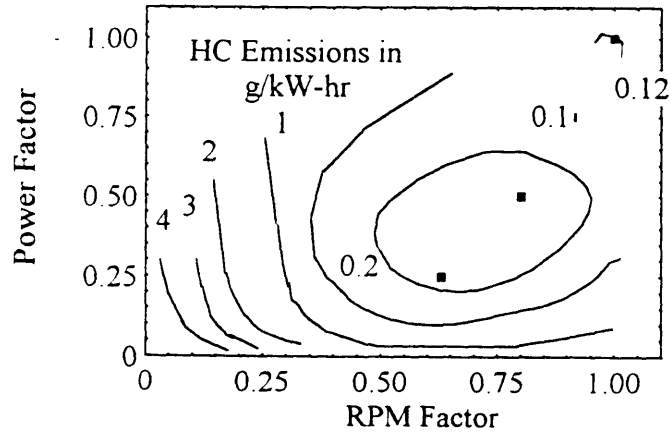
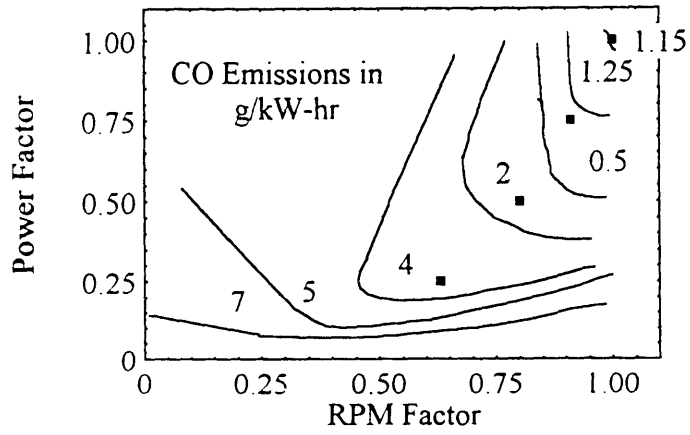
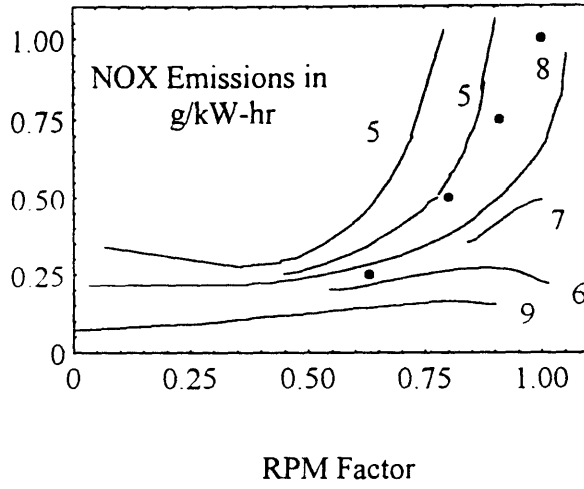
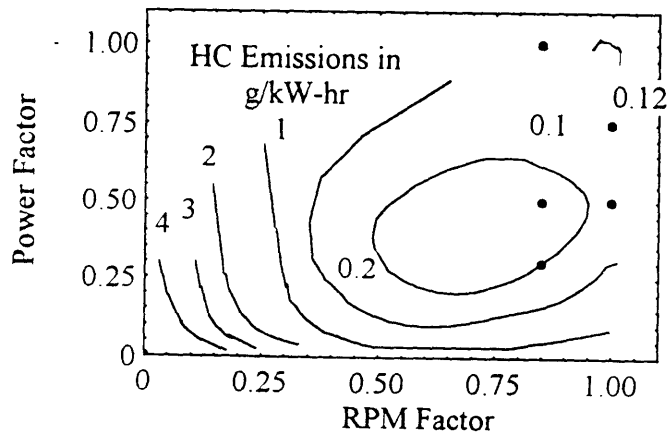
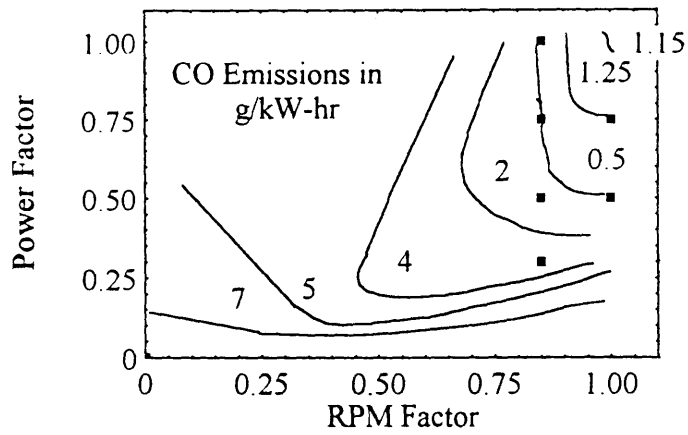
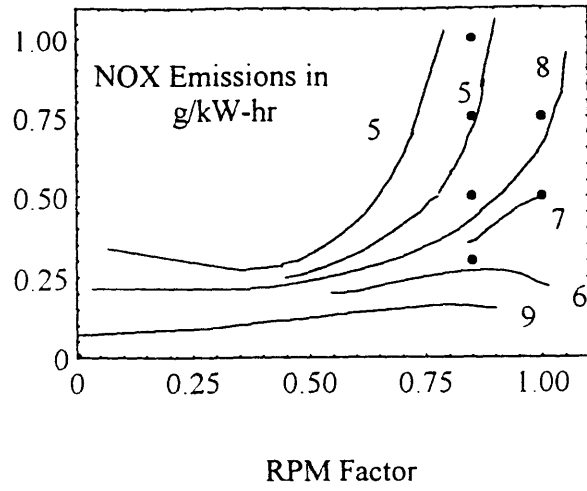


Figure C-5: ISO 8178 Duty Cycle E3



**Figure C-6: CARB 8-Mode Duty Cycle**



**Figure C-7: ICOMIA Heavy-Duty Diesel Duty Cycle**

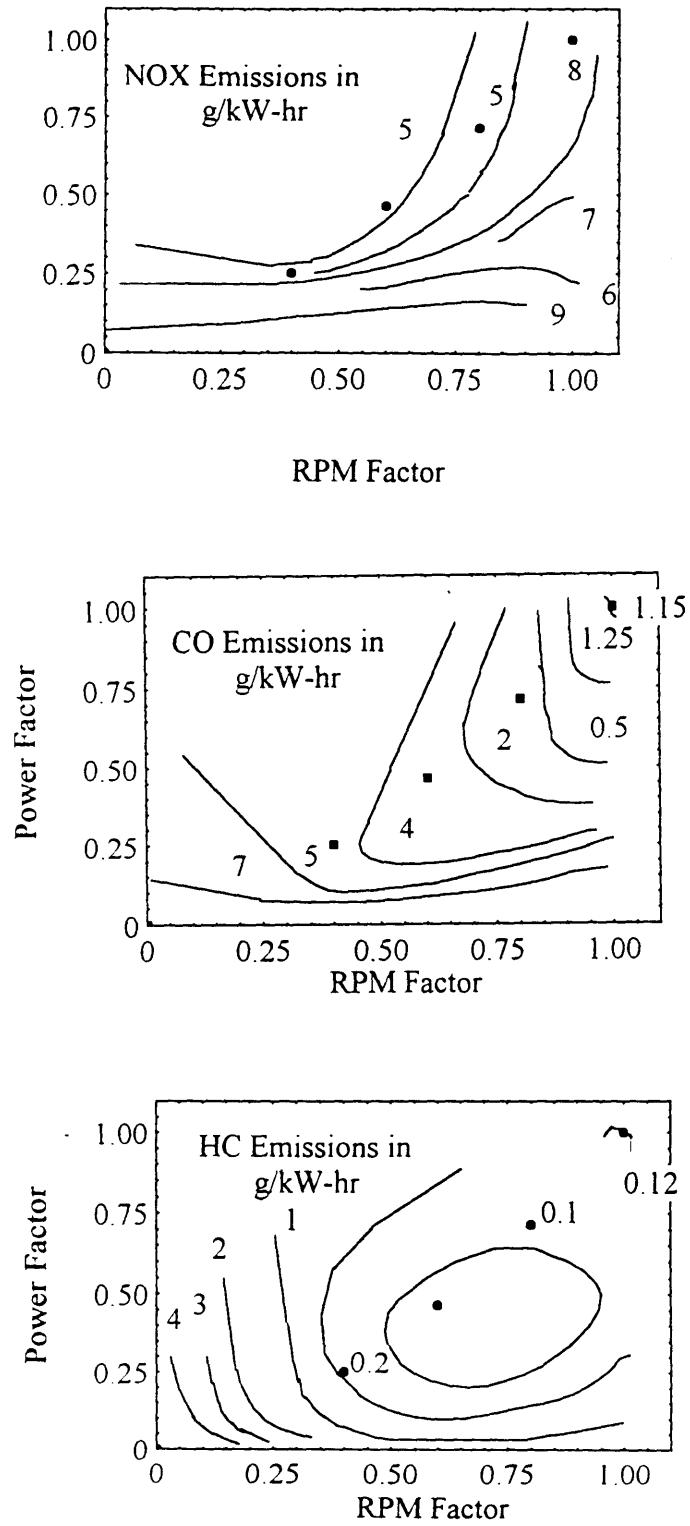
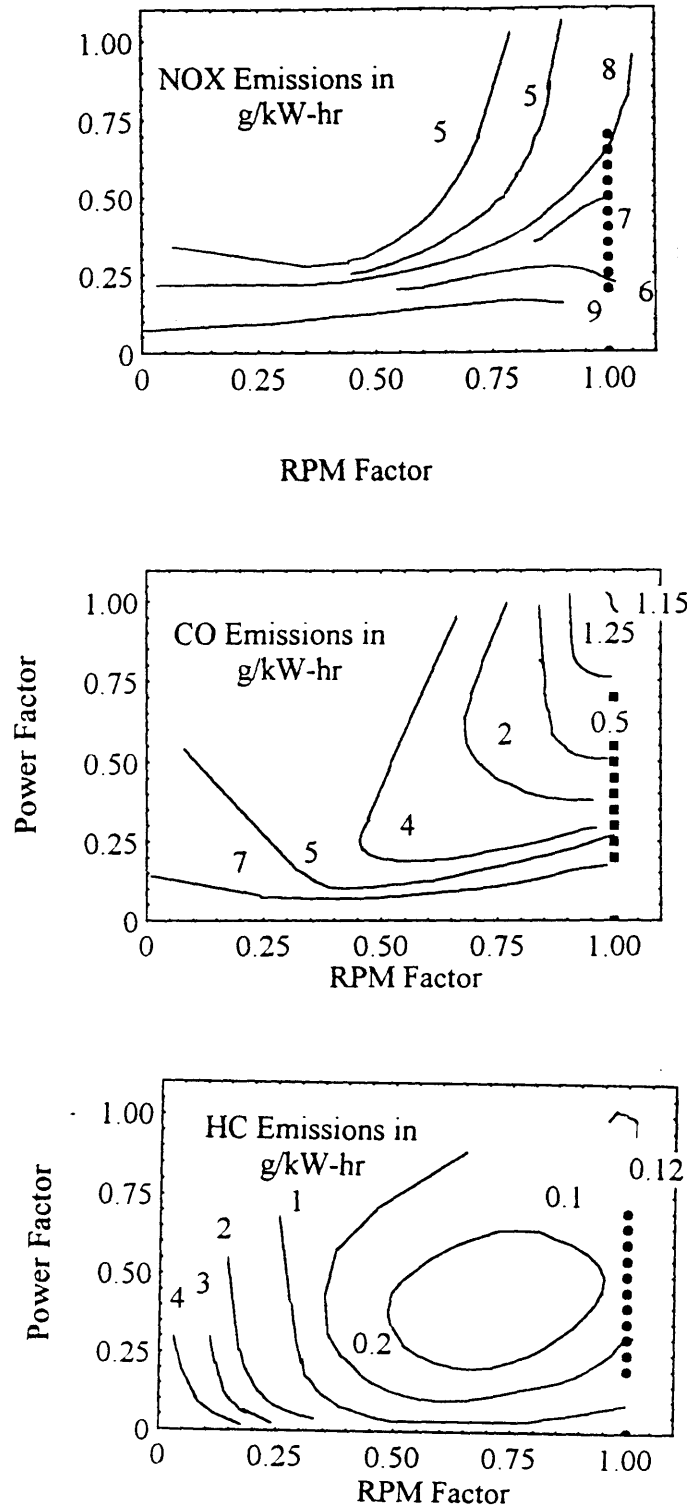
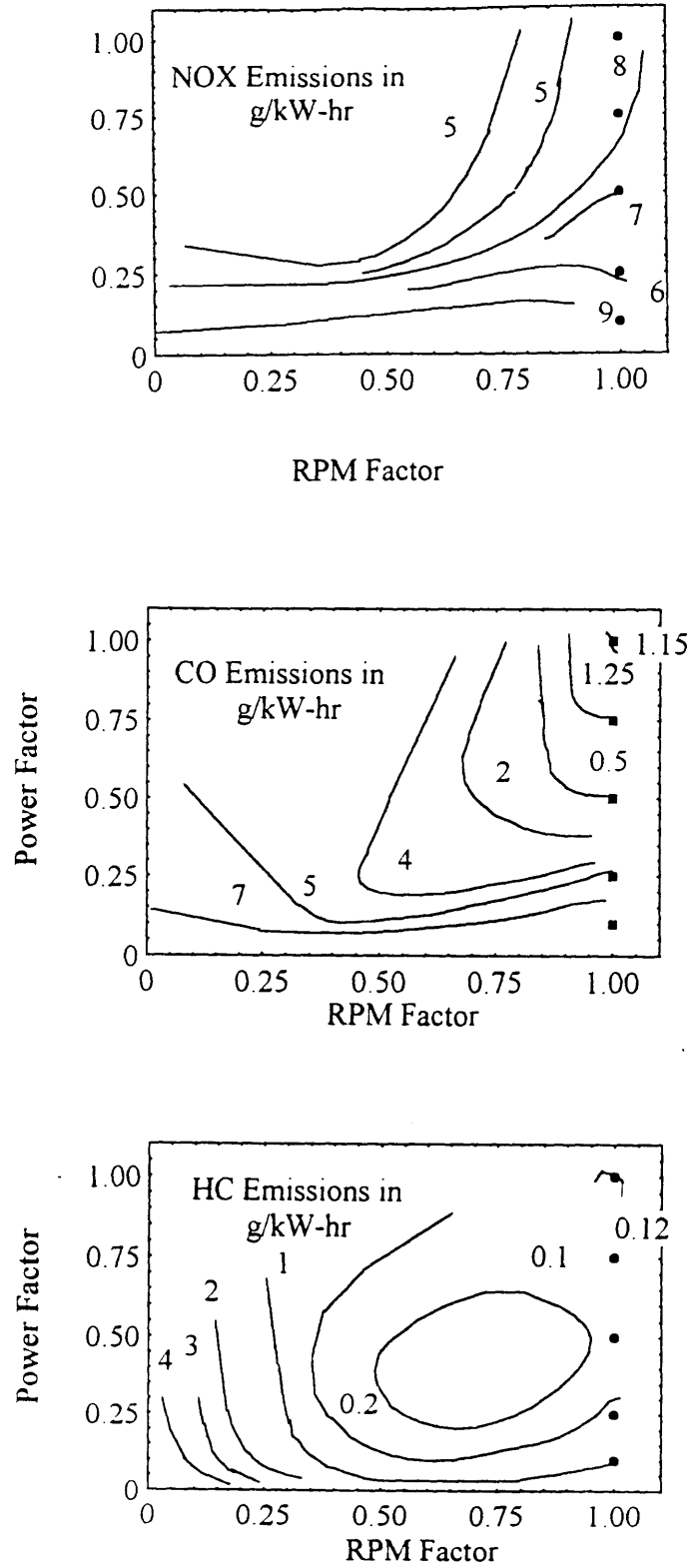




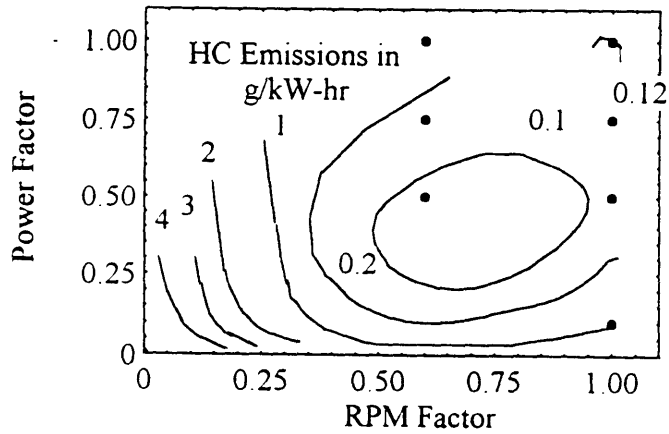
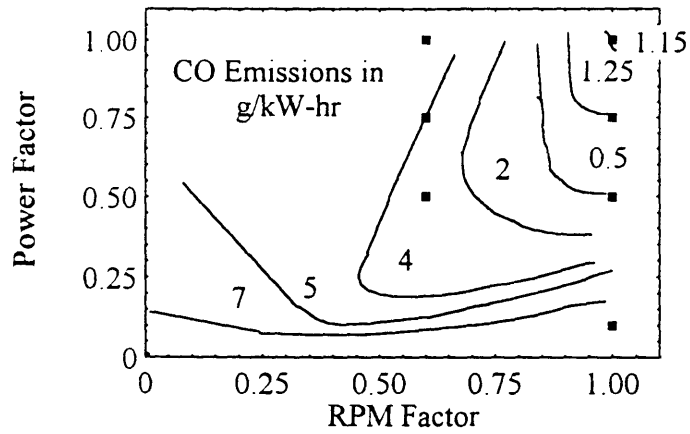
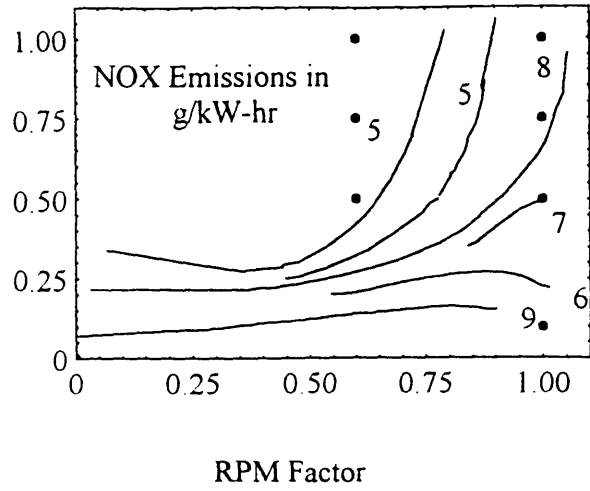
Figure C-8: MCM-1 SSDG Operating Points



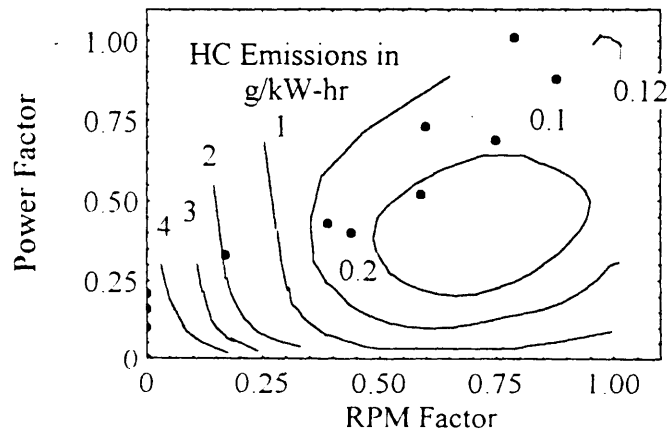
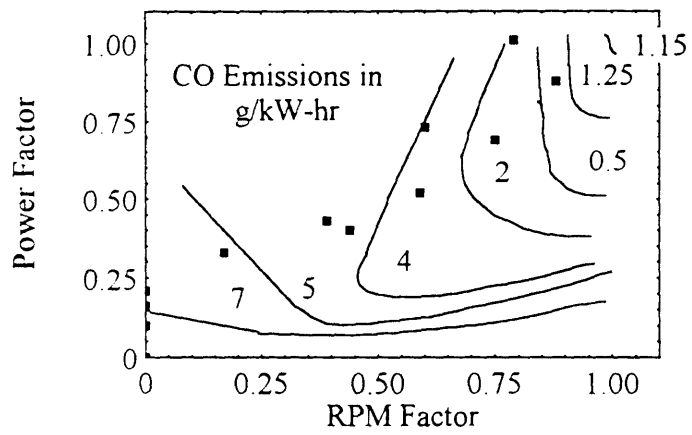
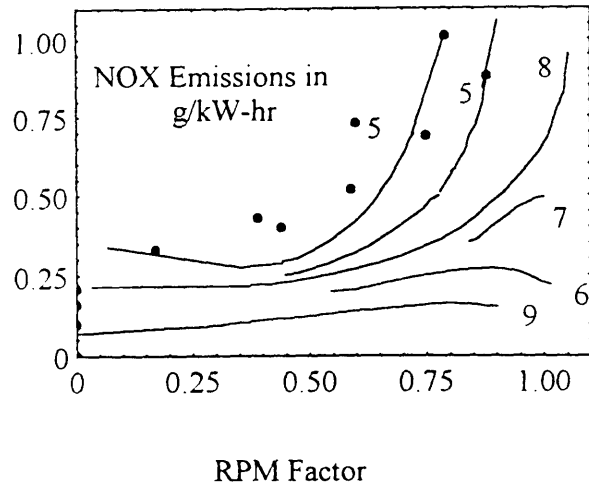
**Figure C-9: ISO 8178 Duty Cycle D2**



**Figure C-10: ISO 8178 Duty Cycle C-1**



**Figure C-11: MCM-1 SSDG Duty Cycle**



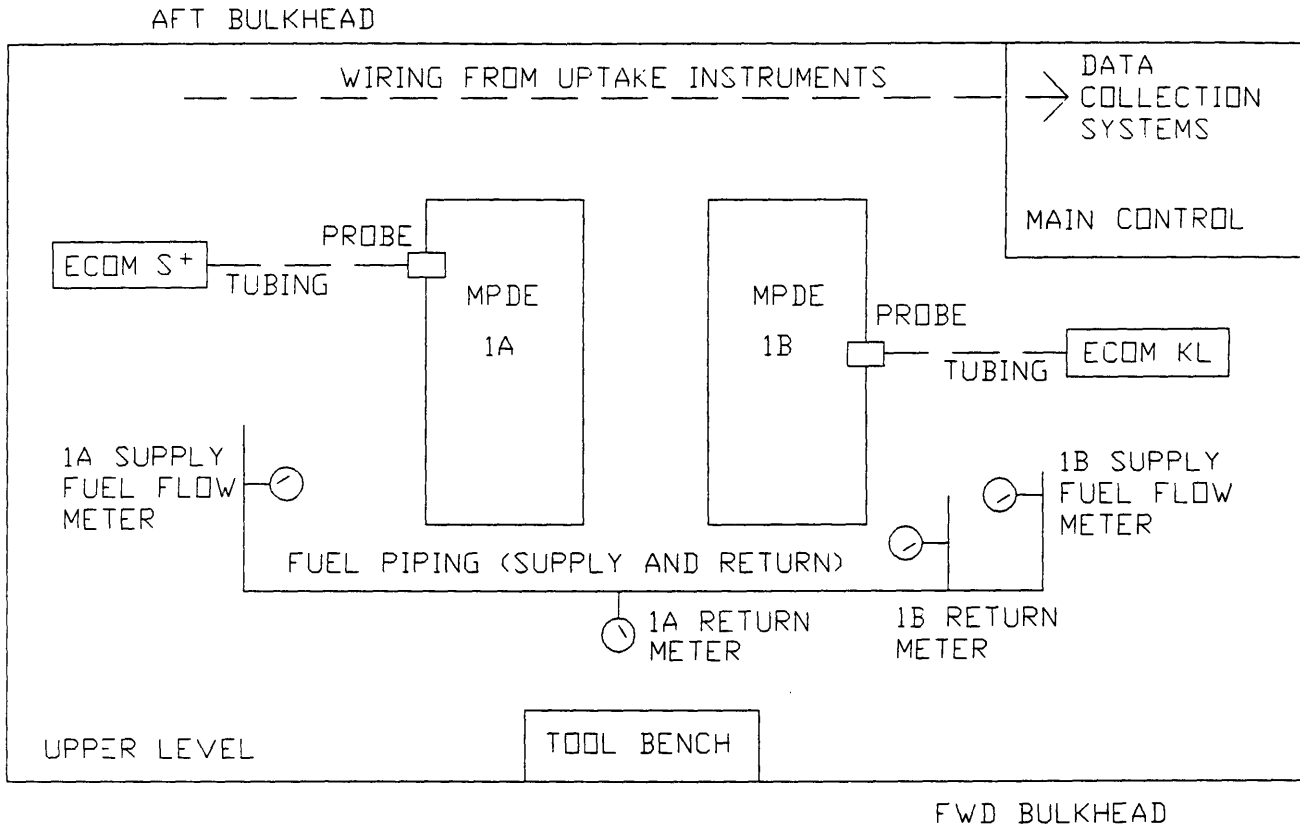
## **Appendix D: Experimental Instrumentation**

Included in this appendix are the ISO 8178 accuracy requirements (Table D-1), schematics of the instrumentation set-up in both the uptake room and Main Machinery Room #1 (Figures D-1 and D-2, description of the instrumentation features (D-4 through D-16 ) and calibration data (D-17 through D-24).

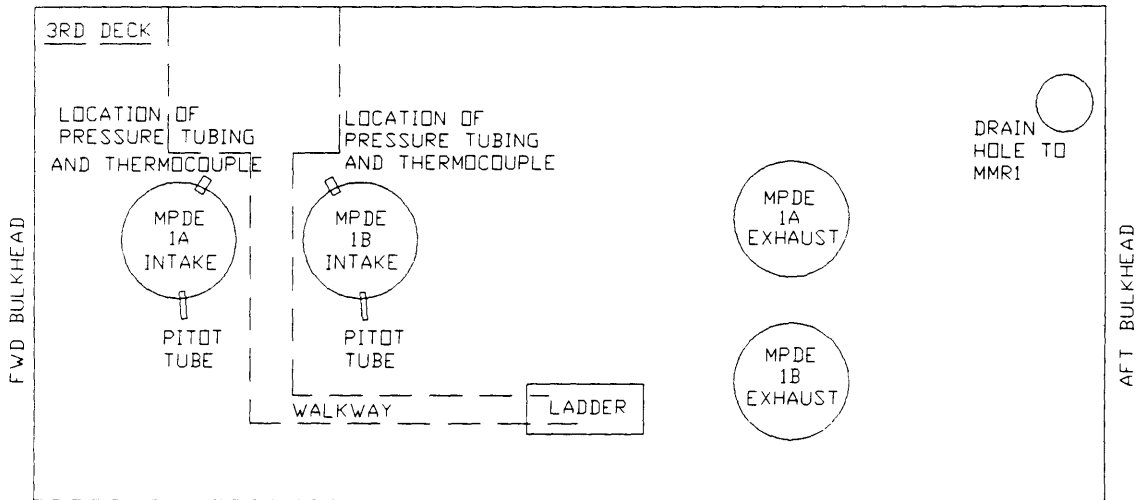
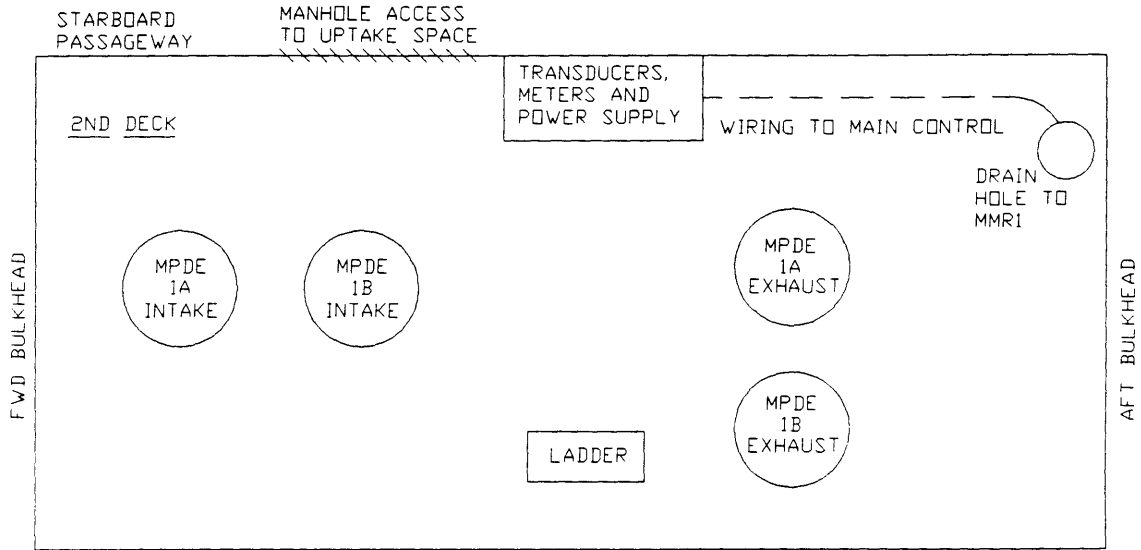
**Table D-1: ISO 8178 Accuracy Requirements**

Item	Permissible Deviation	Calibration Interval
Engine Speed	2% Max Value	3 months
Torque	5% Max Value	3 months
Power	5% Max Value	
Fuel Consumption	4 % Max Value	6 months
Air Consumption	5% Max Value	6 months
Coolant Temperature	2° Kelvin of Reading	3 months
Lubricant Temperature	2° Kelvin of Reading	3 months
Exhaust Gas Pressure	5% of Reading	3 months
Combustion Air Inlet Temperature	2° Kelvin of reading	3 months
Exhaust Gas Temperature	15° Kelvin of Reading	3 months
Atmospheric Pressure	0.5% of Reading	3 months
Intake Fuel Humidity	3% Absolute	1 month
Fuel Temperature	2° Kelvin of Reading	3 months
Exhaust Gas Flow	5% Max Value	6 months

**Figure D-1: Machinery Room #1 Instrumentation Layout**



**Figure D-2: Uptake Space Instrumentation Layout**



## **Instrumentation Description**

### **1) Volumetric Fuel Flow Rate:**

The fuel flow meters were supplied by the Naval Sea Systems Engineering Station (NAVSSSES), Philadelphia. The four meters were all model number HO1X1-6-50-B-1M-F1SS, turbine flow meters manufactured by Hoffer, Inc. Two meters were installed per engine, one in the supply piping and one in the engine return fuel piping. The installation sites were selected to correspond with the sites used during the ship's Acceptance Trials. Preselected horizontal runs had been designed to include short, easily removable sections of piping to support fuel measurements. The existence of these flanged spool pieces were adequate for the development of fully turbulent flow patterns, a requirement of the turbine flow meters. The use of this approach greatly eased fuel flow meter installation time and effort.

The flow meters used during the experiment were of the bearing ball type, as opposed to a positive displacement type meter which was used during the ship's Acceptance Trials. Ball bearing type meters are easier to install and less bulky to transport. Review of Figure G-1 indicates that the measured fuel flow rates using the ball bearing turbine meter were equivalent to the measurement taken with the positive displacement meter. The small deviations can be attributed to small changes in the viscosity of fuel oil, fluctuations which the positive displacement meters can ignore but should be corrected for when using ball bearing flow meters.

The advertised accuracy of these meters is 2% of maximum measurable value.

### **2) Volumetric Intake Air Flow Rate**

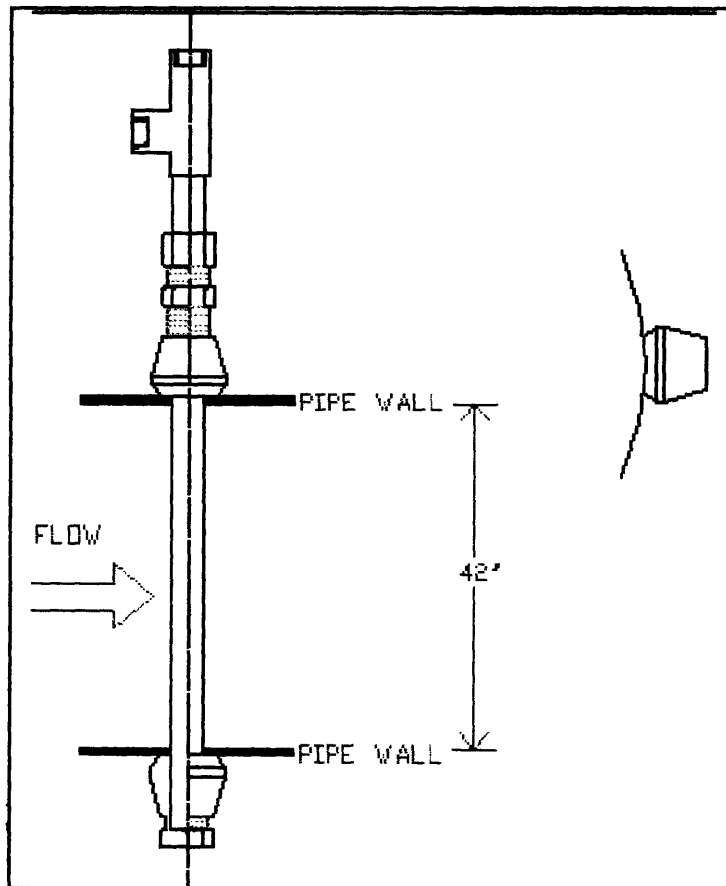
The volumetric intake air flow rate was measured by installing a pitot tube into each engine intake piping. The differential pressure across the tube was measured by a separate transducer also located in the uptake room. The transducer transmitted an electrical signal ranging from 4 to 20 milli-amperes, and correlating in a linear fashion to the differential pressure. As the automated data collection system (located in Main Control) could only receive a 0 to 5 Volt signal, a 250 Ohm resistor was installed in series with the



signal from the pressure transducer.

The requirements for using a pitot tube when measuring flow rate is that the flow must have a fully developed turbulent flow pattern. This ensures that the boundary layer effects due to the walls of the pipe have the smallest possible impact on the measurement. Because of the inaccessibility of the uptake piping, an averaging pitot tube was selected. To avoid resonant vibration, the ACCUTUBE model number 33T double mounted pitot tube was installed. due to the short lead-time on the order, a non-standard 38 inch length pitot tube could not be procured. The 36 inch model was substituted and a small loss in accuracy (up to three percent) was accepted. The fit of the tube into the intake piping is demonstrated in Figure D-3.

**Figure D-3: ACCUTUBE Installation**



The technical requirements for the associated pressure transducers was determined from an estimate of maximum expected volumetric air flow rate (provided by Coltec, Inc.), anticipated air temperature and static pressure and the details of the transducer. Equation D-1 was used to determine the maximum differential pressure which the transducer would need to measure. With a volumetric flow rate of 26,000 SCFM at the high end operating point, the pressure transducer was required to cover a range from zero to 1.4 inches of water. An adjustable range differential pressure transducer could not be located within the time constraints of the experiment. Therefore, an Omega Model PX154-003DI was ordered, with a range of zero to 3 inches of water. This transducer has a linear relationship between amperage and pressure, and the result was that the pitot tube readings only spanned half of the range. The inherent accuracy of the transducer was 1% of the full scale value; it is not anticipated that the mismatching of the pressure ranges would cause the system to greatly exceed the accuracy requirements listed in Table D-1.

$$\Delta P \text{ (inchwater)} = \frac{Q^2 \cdot S_s \cdot (T+460)}{K^2 \cdot D^4 \cdot P \cdot 16.59} \quad (D-1)$$

where  $\Delta P$  denotes the pitot tube differential pressure (units of inches of water column)

Q denotes volumetric air flow rate (units of SCFM)

$S_s$  denotes the medium specific gravity at 60° F

T denotes the medium temperature (units of ° F)

D denotes inner diameter of the piping

P denotes the medium pressure (units of psia)

and K is a flow coefficient specific for each model.  $K=0.757$  for this experiment.

### 3) Intake Air Pressure

The inclusion of a large filter assembly and an intake air silencer in the air piping upstream of the pitot tube location will cause restriction to the flow of air through the piping. These restrictions will cause a pressure loss from the ambient air pressure. Based on conversations with the manufacturers, the Naval Sea Systems Diesel Engine Technical

Code, and from review of Avondale Shipyard intake air test results<sup>1</sup>, the maximum pressure loss which could be anticipated on an intake system with clean air filters is four inches of water, vacuum. Despite the small value of the deviation from ambient pressure conditions, a vacuum sensor was added to the instrumentation for completeness. The purpose of the pressure transducer was to allow calculation of the air density based on the measured air pressure and temperature in the vicinity of the pitot tube.

A 3/8 inch NPT fitting was installed in the intake piping and a 25 foot length of vacuum tubing was attached to one end of a tee fitting. The other end of the tubing was attached to the vacuum port of a current output type pressure transducer. The Omega Model PX141 pressure transducer has a range of zero to 1 psi. The half-bridge resistor circuitry creates a linear relation between voltage and vacuum. The zero to five volt signal was then routed to a meter which acted as both power supply for the manometer and amplifier for the signal. The meter box was an Omega model DP25-S Strain Gage Panel Meter.

It should be noted that all signals originating in the uptake space required amplification due to the length of the cable run from the mouth of the uptake space (where the meters and power supplies were staged) through a drainpipe to the space below and along the rear bulkhead of Machinery Room #1 into Main Control. This routing could not be avoided due to the inaccessibility of the uptake space during engine operation.

#### 4) Intake Air Temperature

The same fitting which supported the vacuum tubing for the intake air pressure vacuum measurement also acted as the foundation for a thermocouple installation. It was anticipated that the restrictions to the air flow through the 38 inch diameter pipe would cause the temperature of the intake air to rise very little over the ambient conditions. A Chromega-Constantan alloy, ungrounded thermocouple was selected based on predicted temperature ranges from freezing to less than one hundred degrees Fahrenheit. An Omega

---

<sup>1</sup> Diesel Engines Combustion Air and Exhaust System Test, LSD-49 Test Procedure 5B259C401, Avondale Shipyard, April, 1994, pp.2-24.

Model GEQIN-18U-18 thermocouple was paired with an Omega MCJ Miniature Cold Junction Compensator to provide a milli-voltage signal linearly related to the measured temperature. The eighteen inch long thermocouple probe had sufficient length to extend into the piping and gather a representative sample from the flow.

The voltage signal out of the ice-point compensator required amplification. David Taylor Research Center (DTRC) provided two Ectron Model amplifiers (Numbers 4892 and 4893) with gains of 1000. The signal reaching the automated data collection system was of the correct voltage, ranging from zero to 5 Volts.

#### 5) Engine RPM and Shaft Torque

The installed machinery electronic control system provides visual indications of important machinery control readings to a remote panel in Main Control. The signals which feed these indicators range from zero to 5 Volts and are related to the system monitored by well known, linear relationships. Two of these system were the shaft torsionmeter and the engine RPM indicator. The control signals for these two systems were tapped at the remote console in Main Control and copied directly into the automated data recording system. The connections were made via isolation amplifiers to preclude interference with the control system should power from the automated data collection system be lost.

DTRC expressed some concern that the ship's installed torsionmeters may lack sufficient accuracy for the purposes of the experiment. The torsionmeters had been groomed by the manufacturer during the ship's repair availability, and he verified that the meters were performing well within the 5% accuracy requirements. Manual collection of the shaft RPM and propeller pitch angle were collected as a secondary measurement. These can be correlated to engine power through relationships developed from Standardization Trials data.

#### 6) Exhaust Emissions Concentration

The ECOM Portable Emissions Analyzer was selected to determine the exhaust

gas composition. The assembly consists of a probe mounted in a pistol grip, a gas cooler, various electrochemical cells, and a standard computer interface. The probe is installed directly into the exhaust stream, at a sufficient depth into the flow to ensure that a representative sample is drawn. Since the probe can only gather data at its tip, it is important that the exhaust gas be well mixed at the point of collection. The probe was inserted into the exhaust piping approximately two feet aft of the turbocharger exit, using a manometer connection fitting installed for a previous set of trials. At this location aft of the turbocharger, it is reasonable to assume that the exhaust remains well mixed.

A small globe valve was screwed into the manometer fitting to support the ECOM probe and provide a means of isolating the exhaust gases in the event the probe was to be removed. This valve fit well on Engine 1B but could not be used with Engine 1A due to piping interferences which impeded insertion of the probe. The length of the probe inserted into MPDE 1A was adjusted to match that of MPDE 1B, but little could be done to halt exhaust blow-by while the ECOM probe was installed in MPDE 1A.

Two models of the ECOM Portable Analyzer were used. The older model, the ECOM KL, was used on MPDE 1B. The ECOM S+, on loan from the manufacturer, was applied to MPDE 1A. Both of the sensors measured the same exhaust constituents, using the same electrochemical processes. The primary differences between the two units were the computer interfaces, the user interface, and the method for drying the exhaust sample gas.

Both ECOM units were set to measure CO, NO, NO<sub>2</sub>, O<sub>2</sub>, exhaust temperature and room temperature. The exhaust gas was drawn into the unit via the probe and a short run of tubing. For this experiment, the distance between the probe and the analysis unit could be kept to less than five feet. Due to the high exhaust temperatures and short run of tubing, condensation in the sample line was not anticipated and a heated sample line was unnecessary.

The internal working of the ECOM analyzer is standard. A small fraction of the engine exhaust is drawn off into the sample line. It is passed through the gas cooler which condenses and separates any entrained water vapor. The dry sample is then routed to two

different types of sensors, the oxygen sensor and the toxic sensors. The oxygen sensor can be compared to a metal-air battery. The metal in the sensor is oxidized by the oxygen of the exhaust stream. The maximum signal is created for ambient air (21% oxygen content); the signal decreases with lower oxygen concentrations.

The toxic sensors consist of the CO, NO and NO<sub>2</sub> sensors, which can selectively react chemically with a particular gas component in a predictable manner. These sensors have both a measurement reaction (oxidation) and counter reaction (usually reduction). The reference electrode maintains constant conditions in the cell. An auxiliary electrode is included to compensate for large cross-sensibilities.

The ECOM units are calibrated by adjusting the electrical signal to a known chemical composition. Small canisters holding the calibration gases for the ECOMs were transported aboard. The calibration gases can be considered inert due to the low concentrations at which calibration is performed (1000 ppm CO, 1010 ppm NO<sub>x</sub> and 550 ppm NO<sub>2</sub>).

In addition to the exhaust composition, the ECOM unit also provides ambient air and exhaust gas temperature readings. The exhaust temperature was monitored between speed changes in an attempt to gauge when the engine had reached steady state operating conditions.

The ECOM Portable Analyzers have been approved by the EPA as adequate for determination of exhaust gas constituents based on demonstrations conducted by the manufacturer. While not a NDIR (Non Dispersive Infra Red) type analyzer required by ISO 8178, it can be considered equivalent.

#### 7) Ambient Air Pressure, Temperature and Relative Humidity

A hand-held dry bulb temperature/relative humidity meter was procured prior to testing, but it was received too late to calibrate it against national standards approved instrumentation. It was held as a back-up system, while a psychrometer permanently installed on the ship's bridge was utilized during the experiment. The psychrometer provided both the bridge level temperature and relative humidity, which was converted to

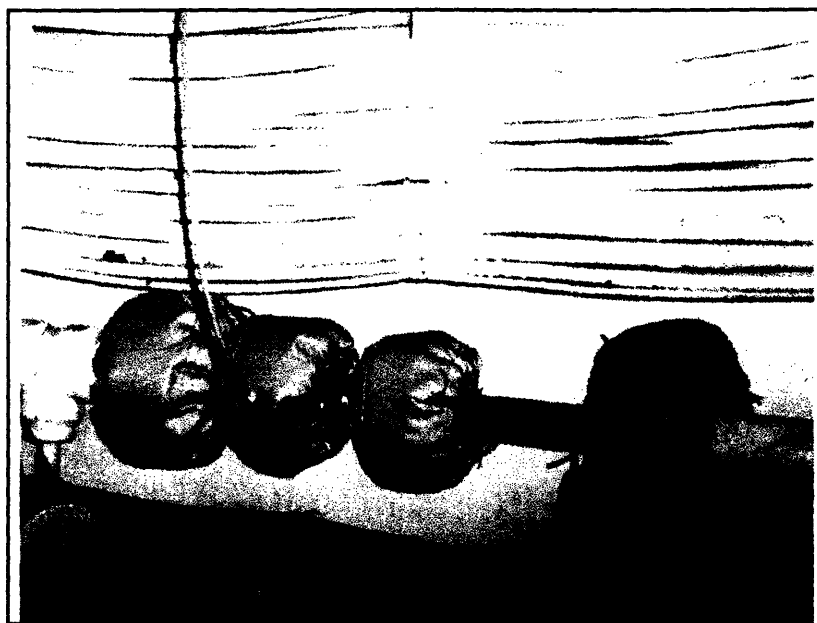
provided both the bridge level temperature and relative humidity, which was converted to partial water vapor pressure using the approach described in Section 4-4.

The bridge level pressure was gathered from the ship's installed barometer. These readings were adjusted to the approximate height of the pitot assembly above the ship's baseline, and the adjusted dry air pressure calculated.

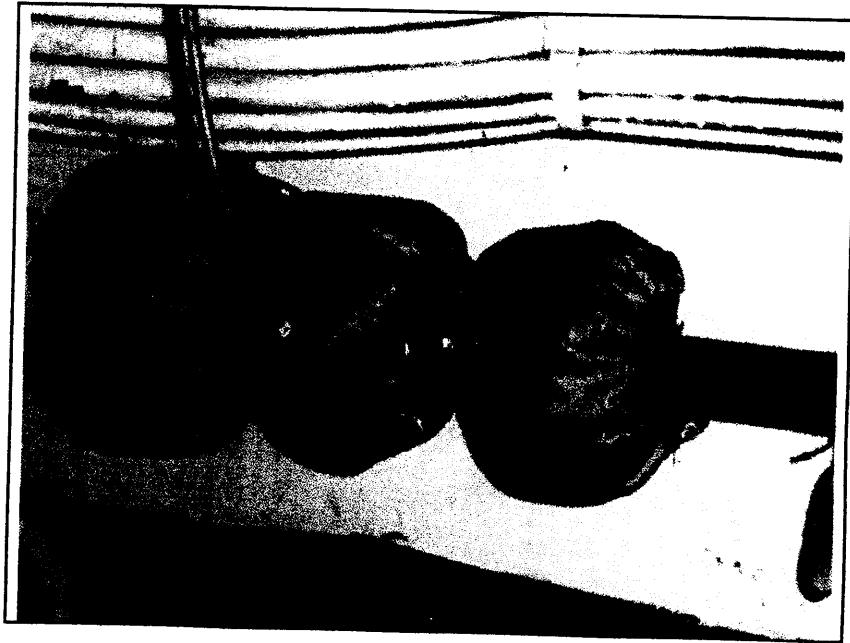
These readings were taken hourly along with sea and wind direction and strength.

Figures D-4 through D-11 are photographs taken with a 35mm camera and speed 200 film. Each component of the installation is displayed, and an attempt to demonstrate the tightness of many of the working spaces in the area of the installation is undertaken.

**Figure D-4: Distant View of Fuel Flow Meter (MPDE 1A Supply)**

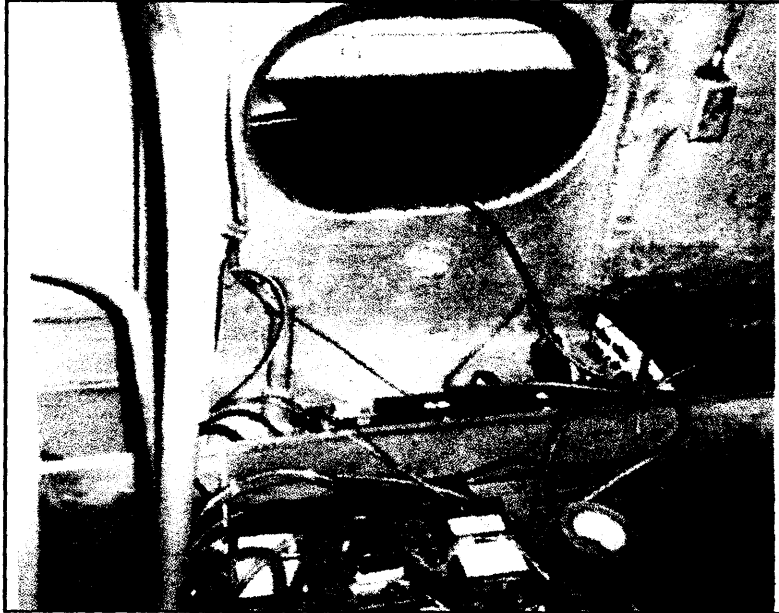


**Figure D-5: Close View of Fuel Flow Meters (MPDE 1A Supply and 1B Return)**

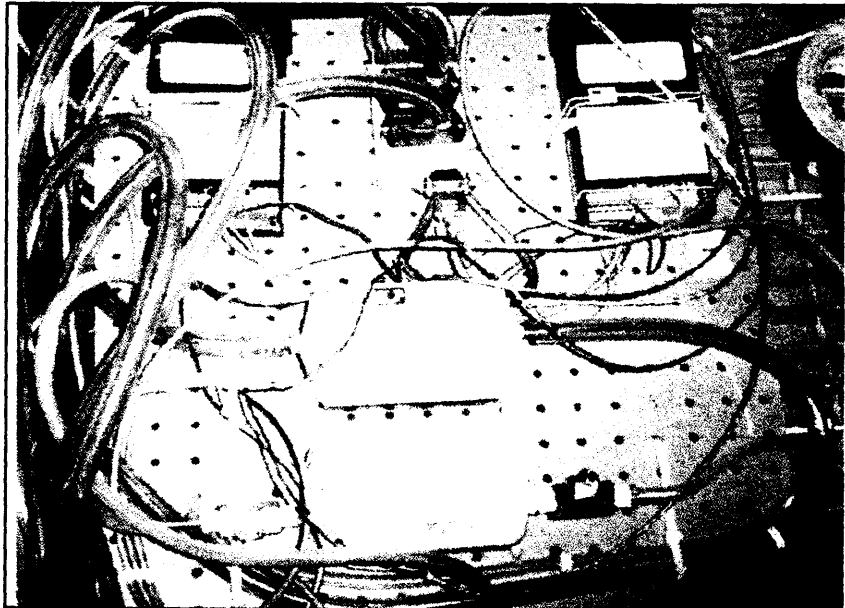




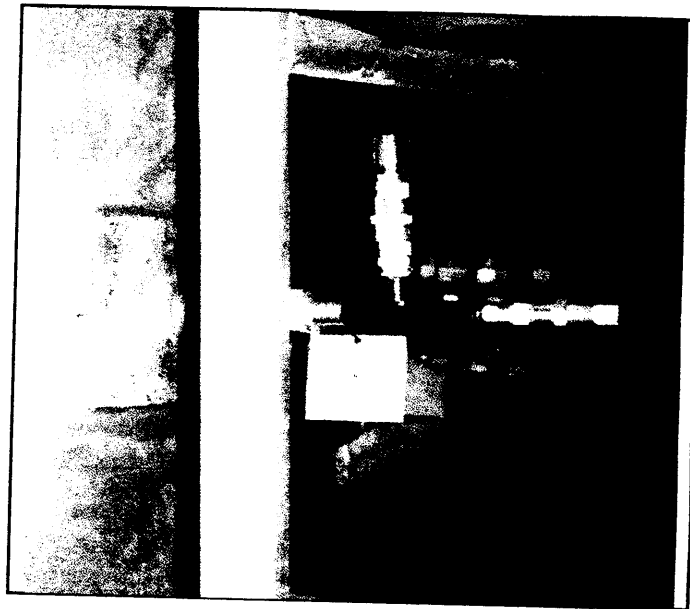
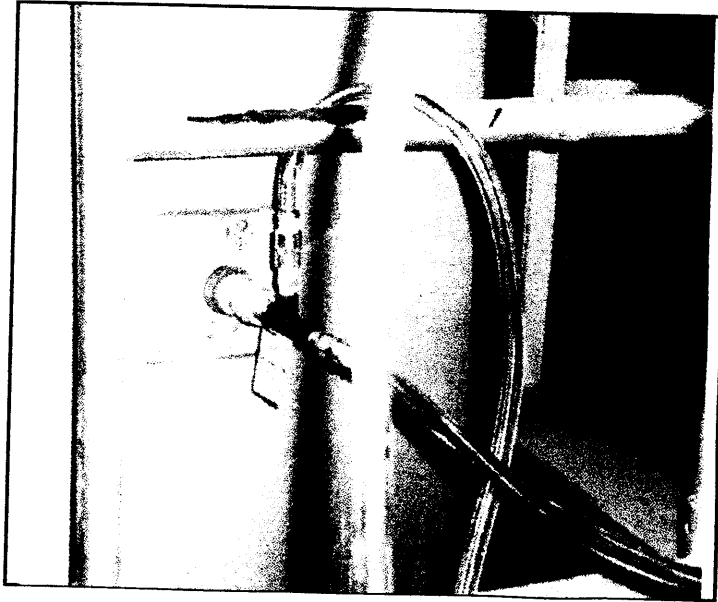
**Figure D-6: Uptake Space Entry (From Inside Space)**



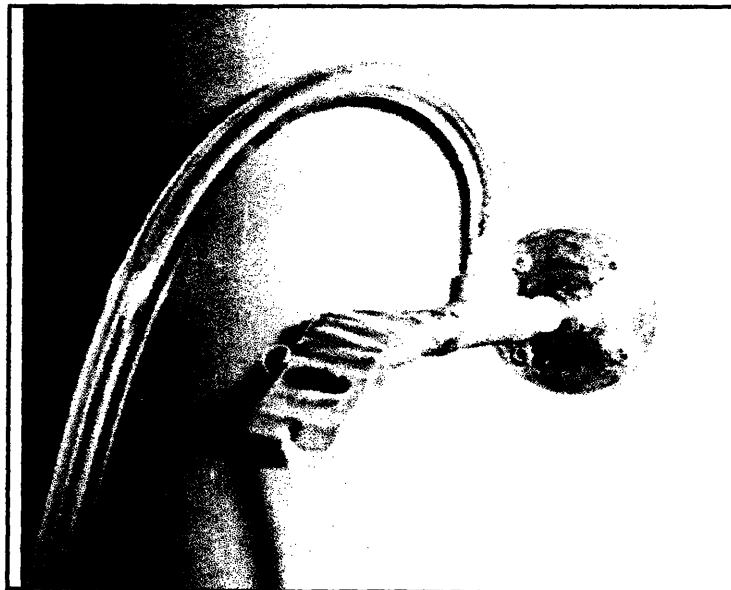
**Figure D-7: Mounting Board with Pressure Transducers, Meters and Power Supplies**



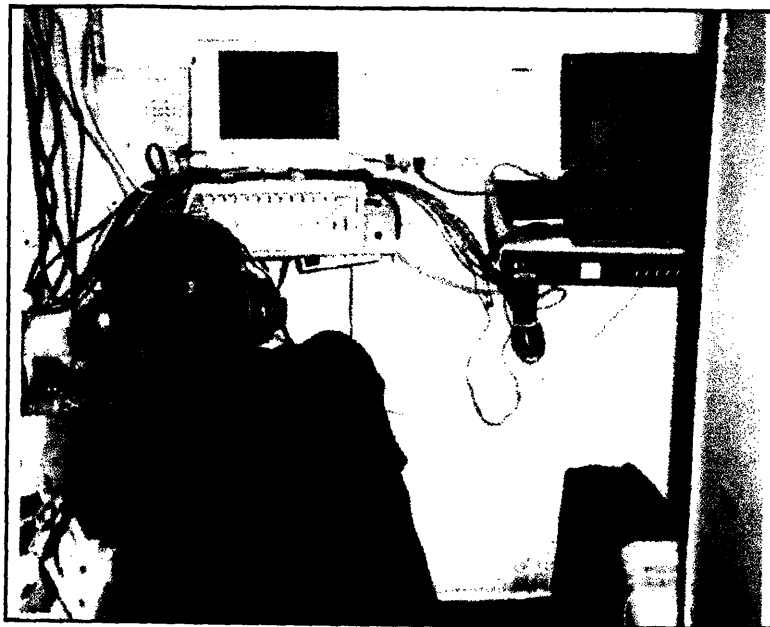
**Figure D-8: Near and Distance Views of Pitot Tube (MPDE 1B Intake)**



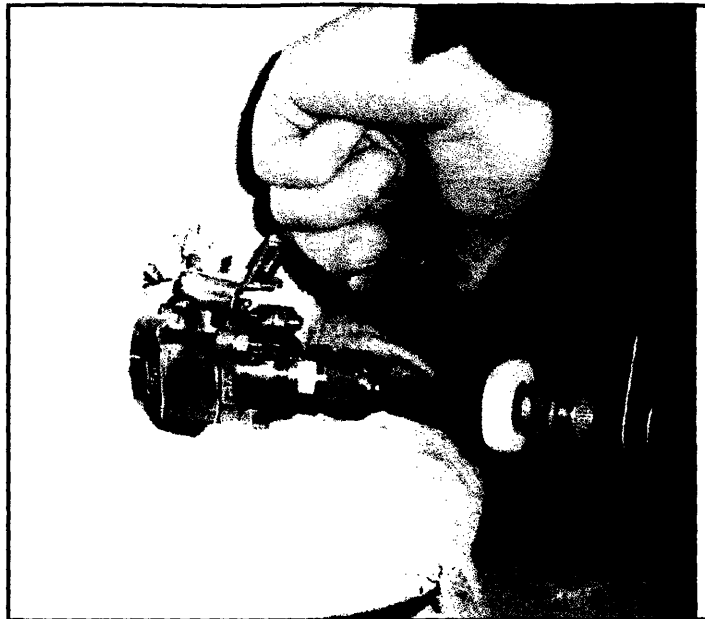
**Figure D-9: Thermocouple and Pressure Transducer Tubing (MPDE 1A Intake)**



**Figure D-10: Automated Data Collection Station (Main Control)**



**Figure D-11: Valve and ECOM Probe Being Positioned (MPDE 1B Exhaust Piping)**

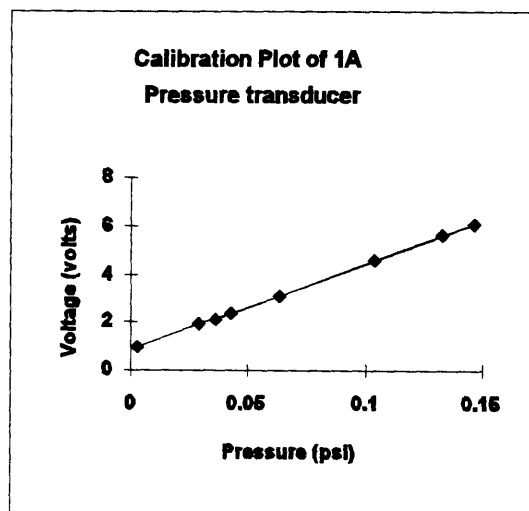
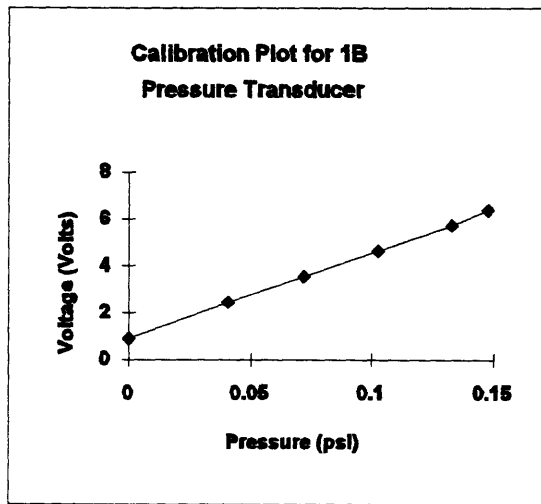


## Calibration Information

All instrumentation was shipped with calibration data. This was verified independently for the pitot tube pressure transducer, the thermocouple and ice point compensators and the ECTRON amplifiers. The calibration data for the fuel flow meters was provided by NAVSSES, Philadelphia.

Figure D-12 is the calibration curves for for the Omega Model PX154-003DI pressure transducers (used in conjunction with the pitot tubes to measure intake air volumetric flow rates). Figures D-13 ia a sketch of the calibration set-up . Table D-2 provides the calibration slopes and intercepts.

**Figure D-12 : Pressure Transducer Calibration Curve**





Institute Archives and Special Collections  
Room 14N-118  
The Libraries  
Massachusetts Institute of Technology  
Cambridge, Massachusetts 02139-4307

**This is the most complete text of the thesis available. The following page(s) were not included in the copy of the thesis deposited in the Institute Archives by the author: 142**

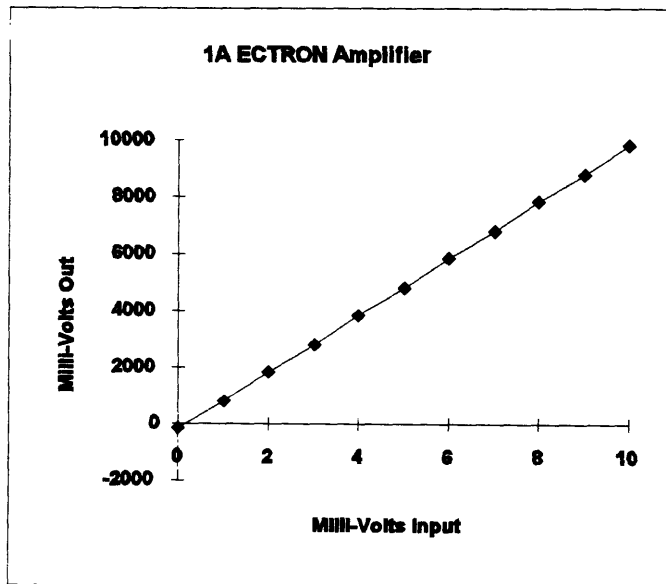
**Table D-2: Pressure Transducer Calibration Information**

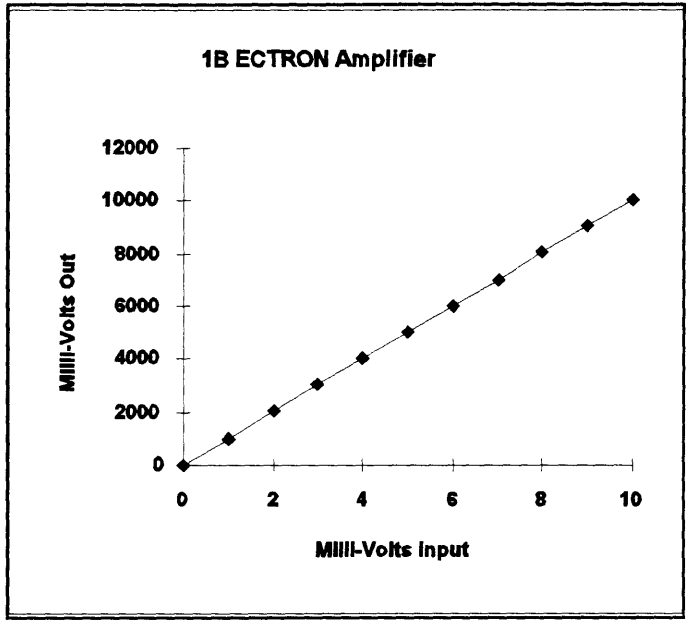
Pressure Transducer	Slope	Zero Intercept
1A	35.8	0.849
1B	36.2	0.953

The pressure transducer calibration was repeated for the 1B unit with the leads swapped so that the high pressure signal was introduced to the low pressure port. The unit responded with a negative slope for a few pressures, but then steadied out to a constant value despite the increasing pressure signal. It is believed that the low pressure port was designed to handle only a limited range of pressure, and that this range was exceeded during the LSD-48 testing. The differential air intake pressure across MPDE 1B's pitot tube could be salvaged.

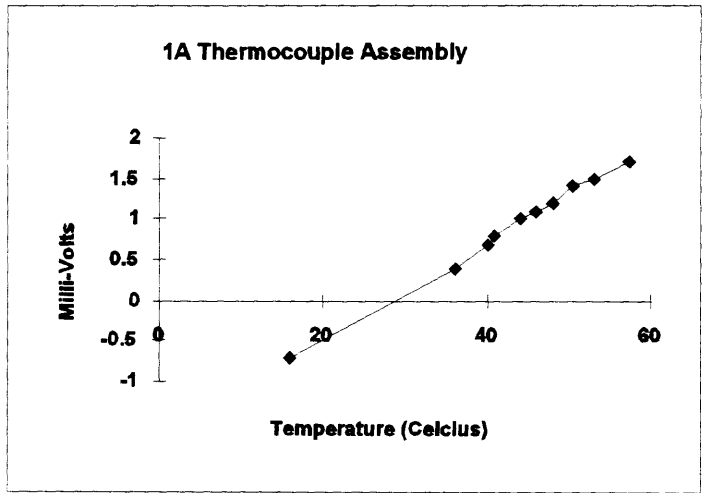
The Calibration Curve for the ECTRON amplifiers is provided as Figure D-14. The thermocouple and ice point compensators calibration plots are included as Figure D-15. Figures D-16 through D-17 are the calibration curves for the fuel flowmeters. The nonlinearity of the K-factor at low frequencies did not effect the experiment's data.

**Figure D-14 : ECTRON Amplifier Calibration Curves**

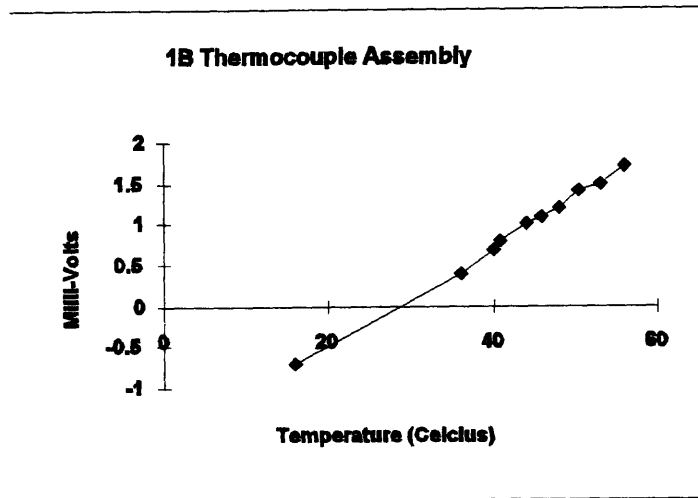




**Figure D-15 : Thermocouple Calibration Curves**







**Table D-3: Calibration Constants for Thermocouples and Amplifiers**

Equipment	Gain (Slope)	Zero Intercept
1A Thermocouple	0.0597	-1.67
1B Thermocouple	0.0607	-1.7
1A Amplifier	1000	16.1
1B Amplifier	1000	-158

The calibration of the ECOM Portable Analyzers was conducted at the U.S. Coast Guard Research and Development Center prior to departing for sea trials. Additional gases were brought to repeat the calibration prior to testing. The amount of calibration gas brought was found to be inadequate, therefore the calibration of the instruments was checked upon return to the R&D Center. The results are summarized in Table C-4. They indicate that some of the sensors had drifted out of calibration. The point in the experiment at which the drift occurred cannot be determined.

**Table D- 4: ECOM Analyzer Calibration Data**

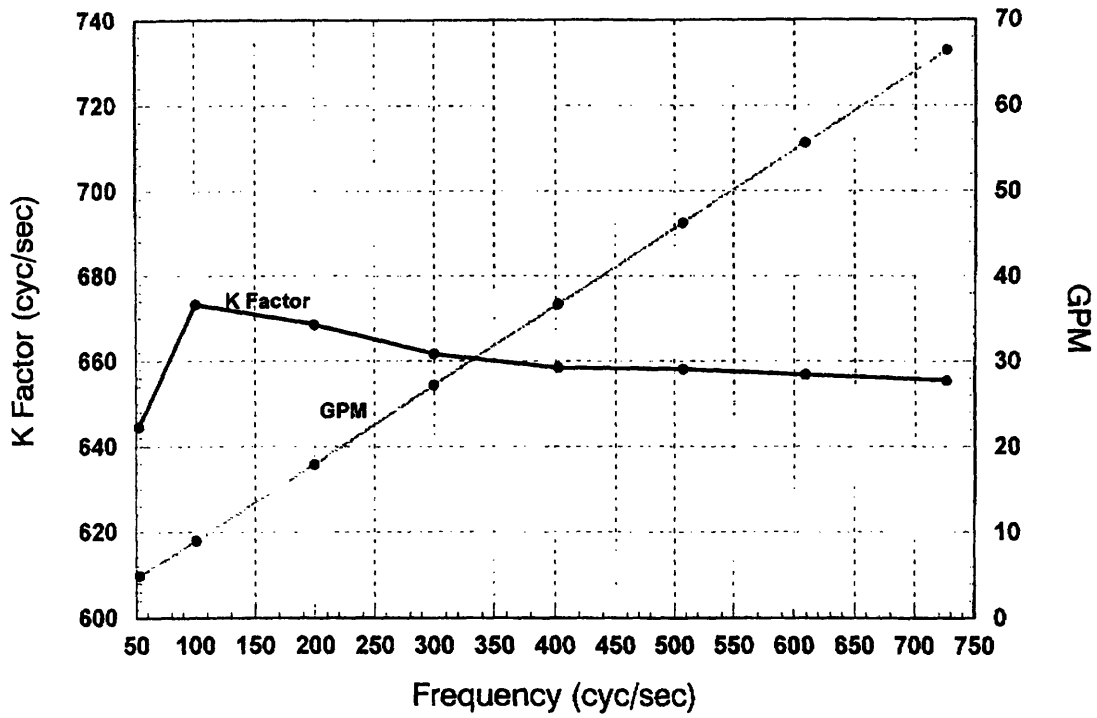
<b>Pollutant</b>	<b>Calibration Gas Concentration (ppm)</b>	<b>ECOM KL Concentration (ppm)</b>	<b>ECOM S+ Concentration (ppm)</b>
CO	1000	980	1007
NO	1010	1036	1026
NO <sub>2</sub>	550	505	326

The impact of the calibrations on the usefulness of the data has been discussed in Chapter 5.

Figure D-16 : Engine 1A Supply and Return Fuel Flow Meter Calibration Plot

### LSD-48 EMISSIONS TESTING

Flowmeter Calibration S/N 26645



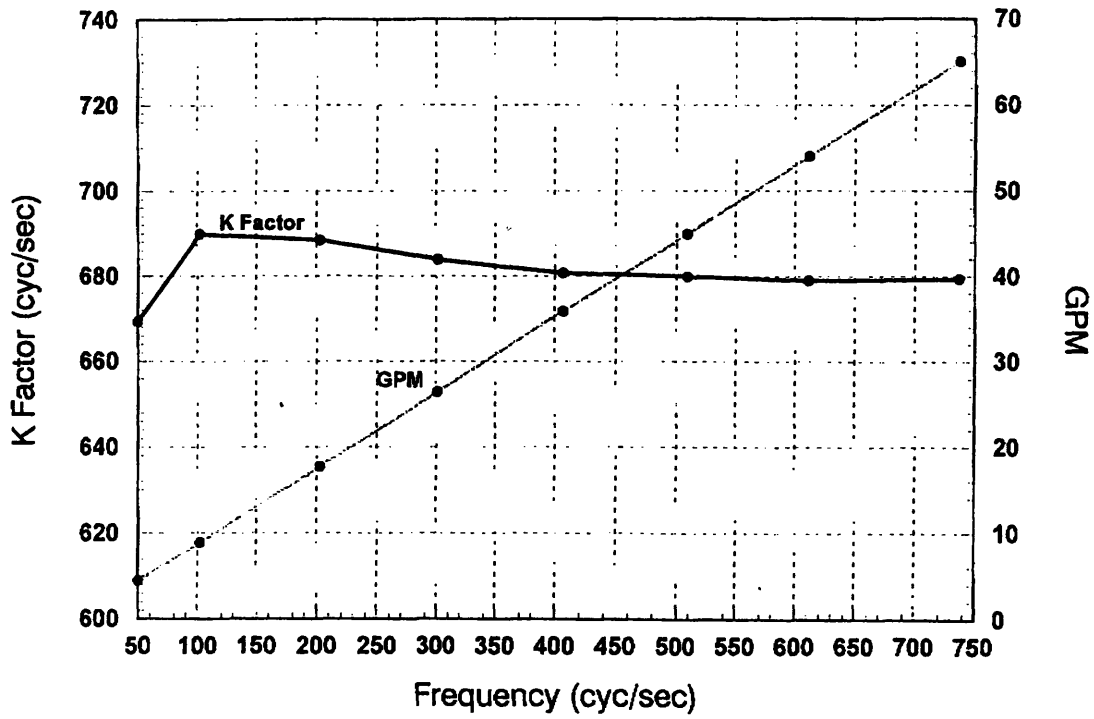
Engine 1A Supply

NSWCCD-SSES-Philadelphia

Figure D-17: Engine 1B Supply and Return Fuel Flow Meter Calibration Plot

## LSD-48 EMISSIONS TESTING

Flowmeter Calibration S/N 26643



Engine 1B Supply

NSWCCD-SSIS-Philadelphia

## **Appendix E: Test Plan**

Attached is the Test Plan which served as guidance throughout the experiment. At conclusion of the test plan are the calculations for the minimum water depths to preclude shallow water effects and increased drag.

TEST PLAN FOR

**SHIPBOARD MAIN PROPULSION DIESEL EMISSION TEST  
ABOARD U.S. NAVY LSD-41 CLASS AMPHIBIOUS SHIPS**

Prepared by

LT A.M. Mayeaux, USN  
Ocean Engineering Department  
Massachusetts Institute of Technology  
Cambridge Massachusetts

February 1995

## **SECTION 1 - General Information**

### **1.1 Proposed Tests**

This protocol describes testing to be conducted on an U.S. Navy LSD-41 Class amphibious ship, the USS ASHLAND (LSD-48), in order to determine the exhaust emissions from a pair of main propulsion diesel engines. The experiment will cover only steady state operations; no transients will be tested. The operating points at which the test will be conducted have been predetermined from an analysis of six months worth of operational data from four sister ships in the class. Various engine characteristics will be measured to support calculations. These include fuel consumption, inlet air flow rate, shaft RPM (SRPM) and shaft torque. The constituents of the exhaust will be measured for each operating point.

This test plan is comparable to one used for measuring exhaust emission aboard U.S. Coast Guard cutters in 1993. MAR, Inc. wrote the protocol for the experiments and analyzed the results (See Reference (a)). The Coast Guard procedure was based on ISO 8178 requirements. Likewise, the procedures of ISO 8178 will be incorporated in this test plan wherever practical.

### **1.2 Test Objectives**

The primary objective of these tests is to validate an engine emissions model developed previously at MIT. If the model is successfully validated, it will be possible to accurately predict cumulative engine emissions without requiring outfitting of the exhaust system with monitoring equipment. The testing will provide a single emission value for each pollutant of interest as a weighted average of the measured mean value at each operating point for the engine. The model also yields a cumulative average value for each pollutant of interest which can be compared to the experimental results. Validation of the model will provide the U.S. Navy flexibility in determining how best to meet Clean Air Act emission standards while maintaining operational effectiveness.

The model is based on research completed by LT Steve Markle, USN in 1994 while assigned as a graduate student at MIT. His analysis (Reference (b)) provides the weighted operating points that will be used during testing of the ship's engines. The single emission values for pollutants of interest derived from this testing can be compared to theoretical values based on various other duty cycles to support discussion of the validity of using ISO derived duty cycles for emission testing of U.S. Navy ships.

### **1.3 References**

- a. Goodwin, Michael J., Experimental Design on Marine Exhaust Emissions, Prepared by MAR, Inc., Rockville, Maryland, for U.S. Department of Transportation, U.S. Coast Guard Research and Development Center, October 1994.

- b. Markle, Stephen P., Development of Naval Diesel Engine Duty Cycles for Air Exhaust Emission Environmental Impact Analysis, Massachusetts Institute of Technology Thesis Submittal, Cambridge, MA, May 1994.
- c. ISO/DP 8178-1 RIC Engines - Exhaust Emission Measurements; Part 1: Test Bed Measurement of Gaseous and Particulate Exhaust Emissions from RIC Engines.
- d. ISO/DP 8178-2 RIC Engines - Exhaust Emission Measurements; Part 2: At Site Measurement of Gaseous and Particulate Exhaust Emissions from RIC Engines - Special Requirements for using ISO 8178-1 at site.

#### **1.4 Location, Time and Duration of Tests**

Location - Aboard LSD-48 USS ASHLAND, Norfolk VA

Time - 14 through 16 FEB 1995

Duration - Testing will be conducted in conjunction with scheduled sea trials following a Phased Maintenance Availability. All instrumentation will be installed during the two days prior to the trials. All testing will be accomplished in designated time slots during the three day trial period.

#### **1.5 Test Preparations**

Crew Training - No additional crew training is required.

Prior Tests Required - Simultaneous recording of emissions from two main propulsion engines requires the use of two portable emission collection and analysis systems (the ECOM-RD portable emission analyzer will be used). Testing to compare the accuracy of the two different ECOM instruments which will be used was attempted at the Coast Guard R&D Center. This testing did not provide conclusive results, but the instruments were judged to be sufficiently similar. The arrangement of the exhaust probe and sampling line will be validated during calibration to ensure adequate flow of exhaust gases to the analysis unit. The physical arrangement and response of the air flow meter (a pitot tube) must be verified.

Facilities and Resources Required - Receipt of shipped equipment and transportation to the ship will be arranged through SUPSHIP PORTSMOUTH and Metro Marine, Inc.

Personnel Required - As most measuring devices will be connected to a data gathering computer program, only three Coast Guard R&D Center test personnel will be required to collect emissions data and tend the test equipment. Both DTRC and NAVSSES will provide one technician to support pertinent equipment.



Test Equipment, Applied Instrumentation and Data Recording Equipment - The test equipment required is discussed in Section 1.6 of this report. Equipment accuracy requirements are specified in Reference (d) Section 7.3 unless otherwise stated.

## **1.6 Methods of Measurements**

The measurement methods proposed below must be shown to demonstrate the accuracy requirements imposed by References (c) and (d).

The following measurements will be used in the calculations:

Shaft RPM - The installed shaft tachometer will be used. This data shall be recorded continuously during each test cycle via a signal from the local operating console. All shaft RPM must remain within 2 percent of the nominal shaft RPM chosen for the operating point. Engine speed is proportional to shaft speed for mechanically coupled engines.

Shaft Torque - The installed shaft torsionmeter and a continuous recording signal will be used. The accuracy of these torsionmeters has been questioned and the measurements may need to be verified. This may be accomplished based on Standardization Trial results and measured shaft RPM and propeller pitch angles. In order to provide this redundant torque data, all three signals, (shaft torque, shaft RPM and propeller pitch) will be copied from the operation console.

Fuel Consumption - The exhaust flow rate cannot be accurately measured. Therefore, exact measurements (within 3%) of the fuel used in the engine are required. Turbine flow meters, manufactured and calibrated by NAVSESS, will be installed in both engine supply and return lines. These meters can be electronically connected to data processing equipment to provide a continuous reading.

Air Pressure at the Intake - A hand-held barometer, supplied by Coast Guard R&D, will be used to measure the air pressure in the intake filter room. This is a periodic reading recorded at least hourly but not required to be repeated with every operating point.

Air Temperature at Intake - A thermometer, supplied by the ship, will be hung without obstruction in the air filter room. This also is a periodic reading that should be taken when the air pressure at the intake is measured.

Absolute Air Humidity at Intake - A psychrometer (or equivalent) shall be provided and operated by qualified Coast Guard R&D personnel to measure the humidity in the intake filter room. This measurement should be taken in conjunction with recording of the filter room air pressure and temperature. All three of these measurements will be used to compute the dry air mass and exhaust mass flow rate.

**Fuel Oil Sample** - A sample of the fuel used during the test has been drawn. A sufficient representative sample, approximately one liter, was submitted for constituent and fuel properties analysis. Samples will be drawn whenever a significant variation in the type or quality of fuel is anticipated.

**Exhaust Gases** - The methods for measuring exhaust gases are discussed in Reference (c). The ECOM-RD Portable Emissions Analyzer (both the KI and the S+ models) will be used. The sampling probe will be installed into the exhaust piping just downstream of the turbocharger. Exhaust gas concentrations of CO, NO, NO<sub>2</sub>, SO<sub>2</sub>, O<sub>2</sub> will be measured with the engine at a steady condition. The Excess Air reading, CO<sub>2</sub> level and total NO<sub>x</sub> are then calculated.

**Exhaust Temperature** - Exhaust temperature will be measured using the installed thermocouple on the exhaust gas analyzer.

**Inlet Air Volumetric Flow Rate** - A pitot tube will be installed in an appropriate straight run of inlet air piping to support measurement of the inlet air volumetric flow rate. This reading, in conjunction with the fuel flow rate and calculated air density, determines the exhaust mass flow rate.

**Inlet Air Pressure** - An installed manometer will be used to determine the vacuum at the point where the volumetric flow is measured. This reading is used to calculate the dry air density and absolute humidity of the inlet air.

**Inlet Air Temperature** - An installed thermocouple will be used to determine the temperature of the inlet air at the same point where the volumetric flow is measured. This reading is used to determine the inlet air mass flow rate.

The following measurements will be used to verify the testing conditions:

**Coolant Inlet Temperature** - The temperature of the primary engine coolant entering the engine will be recorded from the installed temperature gages. The cooling water temperature should not vary widely once the engine is properly warmed up. Data from the Engineering Department operating logs may be copied to show hourly changes occurring during the day's testing. These comments also apply to the engine coolant outlet temperature.

**Coolant Outlet Temperature** - The temperature of the primary engine coolant leaving the engine will be recorded from the installed temperature gage.

**Lubricating Oil Inlet Temperature** - The inlet temperature of the lubricating oil to the engine will be measured using installed temperature gages. The oil temperature should not vary widely once the engine is properly warmed up. Data from the Engineering Department operating logs may be copied to show hourly changes occurring during the

day's testing. These comments also apply to the lubricating oil outlet temperature.

Lubricating Oil Outlet Temperature - The outlet temperature of the lubricating oil to the engine will be measured using installed temperature gages.

Draft Readings Fore and Aft - Draft reading will be calculated by the ship's DCA at the beginning and end of each day of testing.

Relative Wind Speed and Direction - The ship's bridge watch will record data from the installed anemometer at least hourly during testing.

Significant Wave Height and Direction - An experienced crew member will record visual observations periodically during testing. Significant changes in the sea condition must be recorded and the ship maneuvered as possible to minimize the sea effects.

Water Depth - An average depth in the test area may be recorded if all testing is performed in deep water (defined in Section 2.1). The depths of the proposed operating area are sufficiently deep to preclude hourly fathometer readings.

The following measurements will be included with the results of the testing. These variables will be important for further analysis of the data.

Reduction Gear Make, Model and Serial Number - Record from reduction gear nameplate.

Engine Make, Model and Serial Number - Record from each engine nameplate.

Engine Injector Size and Timing - Data to be provided by ship's force.

Fuel Rack Position - Fuel Rack Position can be read from the installed engine scale. Shipboard personnel will be asked to provide baseline data and Coast Guard R&D personnel will record these readings during the last three minutes of steady state interval.

Propeller Type (Number of Blades, Diameter, Pitch, Developed Area Ratio) - This information is obtained from ship's force or the appropriate planning yard.

Date of Last Drydocking or Hull Cleaning - The date of the last hull cleaning will be provided by ship's force.

Lubricating Oil Specifications or Sample - The type of lubricating oil used will be ascertained from ship's force. Notes shall be taken on the time since the last oil change. If there is an uncertainty regarding the type or quality of lubricating oil, it must be submitted for NOAP (Navy Oil Analysis Program) sampling.

## **1.7 Hardware Configuration**

The following configuration change to the machinery plant is required: A five square inch stainless steel plate with a NPT fitting must be welded into the air intake piping to support measurements of the inlet volumetric flow rate. A total of two fittings will be installed, one for each engine in Machinery Room Number One. Additionally, a one half inch NPT fitting per uptake must be installed in the vicinity of the previously described fitting to support a manometer/thermocouple.

## **1.8 Data Sheets**

As a result of concurrent testing with DTRC, an automatic data collection system will be available. Appropriate data sheets will be provided to record all data which is not automatically collected. These are included as Attachment "A". (not included)

## **1.9 Pre-Operational Checklists**

The following items should be checked before leaving for the operating area:

- Essential shipboard equipment is operational.
- Pertinent shipboard gages are calibrated.
- Drafts fore and aft are recorded.
- Depth at proposed operating area is satisfactory.
- Sea conditions in operating area are acceptable
- All test instrumentation is installed and is operational.
- Sufficient recording media are on board.
- Tests personnel are trained and know their jobs.
- Ship's crew has been briefed on the test to be performed.

## **1.10 Concurrent testing**

The incorporation of the diesel emissions testing into the ship's Sea Trial agenda must be carefully thought through. The full schedule of the trial may offer few windows for testing team to conduct their analysis in the manner originally planned. Co-ordination and compromises in completing the test agenda is mandatory..

## **1.11 Approvals, Authorities and Responsibilities**

During testing, the ship will be operated by its normal crew. Test instrumentation will be installed by Coast Guard R&D Center personnel with some assistance from the crew. Data recording is the responsibility of the R&D Center and DTRC test personnel. They may request assistance from ship's force for individual items of data as discussed in Section 1.6 of this report.

## **SECTION 2 Testing Procedure**

### **2.1 Test Description**

These test are planned as steady state tests in calm, deep water. While testing conditions may require deviation from ideal test conditions in order to expedite the testing, every effort should be made to remain close to ideal conditions. "Deep water" is a term which is a function of the vessel's maximum cross-sectional area or maximum speed. The minimum water depth for negligible wave making and residual resistance can be calculated using the following equation:

$$Depth (ft) = \frac{(Maximum Speed (ft/sec))^2}{0.10 \cdot g}$$

or

$$Depth (ft) = 3 \cdot \sqrt{Cross Sectional Area (ft^2)}$$

The result with the greatest depth is used. This value is 179.0 feet or approximately 26 fathoms. The depth of the operating area to be transitted during Sea Trials will be verified prior to leaving port. The calculations are included as Attachment "B".

The tests should be conducted with a minimum of wind and wave action. The conditions may be considered "calm" if the significant wave height is less than 0.6 meters (2 feet) and the wind speed is less than 15 knots. Whenever possible, the test should be run with the seas on the ship's beam, especially in high wave conditions. All runs must be made in the same relative direction in the wind and waves. It is recognized that the ship may be limited in it's ability to order the required headings due to limitations in operating space.

Tests shall be conducted at five speeds with one engine per shaft and at seven speeds with two engines per shaft. The speeds have already been selected and are based on a duty cycle developed from an analysis of similar ships' operational logs. Each speed is weighted to reflect the percent of time it is estimated that the vessel operates at or near the operating point. These weights will be used to determine the single number estimate of the LSD-41 main propulsion diesel engine emissions. Table E-1 contains a summary of this data as presented in Reference (b).

Five or seven test runs, one at each operating point and dependent on plant configuration, constitutes a block of runs. For example: one block of runs when configured for one engine per shaft would contain data from five speeds (Idle, 5 knots, 10 knots 15 knots and 17 knots). Data will be collected by repeating each block of runs four times in order to obtain a better estimate of the average amount of emissions at each

operating point. The order of the speed changes (runs) within each block will be random. Requiring each block to possess a different run order will help to ensure that non-measurable external factors will have no effect on the results.

The mean emission rate for each engine and each pollutant of interest will be determined by averaging the four emission readings gathered for each operating point. The confidence interval on the mean values will also be estimated from the data. The mean emission values for each engine will be summed to find the total plant emission figure for each combination of pollutant and operating point. Finally, the weighting factors will be multiplied by the individual operating point emission level and the results summed over all twelve (five for single engine per shaft tests and seven for two engines per shaft tests) operating points to determine a single, cumulative emission level for each pollutant.

**Table E-1: List of Operating Points\* (Converted to Speeds)**

<b>Mode</b>	<b>Ship Speed (knots)</b>	<b>Engines per Shaft</b>	<b>Propeller Pitch %</b>	<b>Shaft RPM</b>	<b>Time Factor</b>
1	0	0	0	64	0.083
2	5	1	52	64	0.064
3	5	2	52	64	0.128
4	10	1	100	66	0.077
5	10	2	100	66	0.141
6	15	1	100	102	0.051
7	15	2	100	102	0.109
8	17**	1	100	116	0.040
9	17	2	100	116	0.16
10	20	2	100	138	0.093
11	24	2	100	165	0.054

\* An operating point is a specific engine power and speed rating.

\*\* May be incorporated with Mode 6 if ship indicates that in their opinion seventeen knots on two engines only is excessive.

In anticipation of proposed EPA legislation, one additional emission measurement will be taken on each engine at the end of each block of runs. The engine will be

operating at rated power and speed for these measurements.

## 2.2 Test Procedure

This section discusses the procedures for an individual test run. All test runs within a block are identical except for the engine speed and torque associated with each operating point.

The run cycle begins with acceleration or deceleration from the previous speed to the test speed required for the current run. Once the engine is nearly stabilized (as determined by a constant efficiency reading from the exhaust monitoring equipment), five exhaust readings are taken. During this interval, the ship should maintain steady course and speed and limit rudder angles to less than ten degrees. At the end of the data collection, the ship will proceed on to the next speed in the sequence.

Data recording for torque, RPM and air volumetric flow will begin at the start of each run cycle and continues to the end. Breaks in the testing may be made between runs to change recording media as necessary. Key points in the sequence of runs must be indicated. These include changes in speed, the start of the steady state run and the data collection interval. Periodic measurements will be taken as discussed in Section 2.4. The start and stop times for each speed run will be recorded as well as the time of each speed change. A convenient run number is assigned to each run for later reference.

## 2.3 Test Schedule

Table E-2 provides twenty random orders for test runs for the single plant per shaft configuration. This is out of a total of 120 possible combinations. Table E-3 provides a similar sampling for the two engines per shaft configuration. To use either table, four column numbers should be chosen blindly and the run orders for the chosen columns used for the testing. The numbers in Table E-2 designate operating points from the lowest (1) to the highest (5). Table E-3 designates two additional operating points (6) and (7).

**Table E-2: Random Run Orders for Single Engine Configuration**

1	2	3	4	5	6	7	8	9	1	1	1	1	1	1	1	1	1	1	2
									0	1	2	3	4	5	6	7	8	9	0
2	2	4	3	1	3	5	4	2	3	1	1	3	5	5	4	1	1	1	3
4	5	3	5	4	2	4	5	3	5	2	2	4	3	2	3	4	2	2	5
3	4	2	4	2	5	3	1	1	1	4	4	2	4	3	1	5	5	3	4
1	1	5	2	5	4	2	3	5	4	5	3	1	2	1	2	3	4	4	1
5	3	1	1	3	1	1	2	4	2	3	5	5	1	4	5	2	3	5	2

**Table E-3: Random Run Orders for Dual Engine Configurations**

1	2	3	4	5	6	7	8	9	10	11	12	13	14	15	16	17	18	19	20
2	3	1	1	1	2	6	2	6	7	1	7	7	4	2	3	5	2	7	4
5	4	7	4	6	5	7	6	7	6	2	6	2	3	1	1	2	4	2	2
3	7	3	5	4	6	5	4	1	1	3	3	6	2	3	7	3	3	3	1
6	5	4	3	3	1	2	5	5	5	7	2	5	7	7	4	4	6	6	6
1	2	5	6	2	4	4	1	4	3	6	4	1	1	5	6	7	5	4	3
4	1	2	7	7	3	1	7	3	4	5	1	4	5	6	5	6	1	1	5
7	6	6	2	5	7	3	3	2	2	4	5	3	6	4	2	1	7	5	7

All runs in a block must be completed before proceeding to runs in the next block. This ensures that a maximum of useable data is available should the testing end early.

All runs testing the same engine and configuration should be made on the same day in as nearly identical conditions as possible. Each run is estimated to take twenty to twenty-five minutes (due to time for the engine to steady after speed changes). For the single engine per shaft configuration, all fifteen runs can be completed in approximately six hours. For the dual engine per shaft configuration, all twenty-one runs should take ten hours to complete.

Attachment "C" details the order in which each block of runs will be completed. (not included)

## 2.4 Data to be Recorded

Continuous data collected:

- Shaft RPM
- Shaft torque
- Fuel consumption
- Air volumetric flow rate
- Exhaust gas elements
- Exhaust gas temperature
- Inlet Air Vacuum
- Inlet Air Temperature

Collected by ship's force:

- Relative wind speed and direction
- Water depth (if necessary)
- Significant wave height and direction
- Draft fore and aft
- Coolant and lubricating oil inlet and outlet temperatures



Other required periodic measurements:

- Pressure of intake air at filter room
- Temperature of intake air at filter room
- Absolute humidity reading at inlet filter room
- Engine rack positions

## 2.5 Data Analysis

During the tests, measurements are made of the exhaust gas components in the exhaust. In order to calculate the total amount of emissions, the exhaust mass flow must be determined. The density of the intake air at the volumetric flow meter will be calculated to provide the inlet air mass flow rate. The fuel mass flow rate will be computed from the fuel meter data and measured fuel density. These flow rates combine globally to provide the exhaust mass flow rate according to the Law of Mass Conservation. The method detailed in Appendix A.1 of Reference (c) shall be used as a secondary method. This is a carbon balance method based on the flow rate of fuel, the components in the fuel, and the measured exhaust concentrations. This analysis must be conducted on each engine for each test run. The resulting emissions in grams/hour are computed from the emissions concentrations (ppm) and the exhaust mass flow rate (kg/hr). The emissions in units of grams/hr are used in all following calculations.

One or more plots will be prepared comparing the relationship between shaft RPM and shaft torque (Nm) and emission rates of CO, NO, NO<sub>2</sub>, SO<sub>2</sub>, O<sub>2</sub> and hydrocarbons. These plots will show the mean value of each dependent variable and the 95 percent confidence interval for each mean value.

The test procedure should eliminate any wide variations in the data. If wide variations are noted, the inconsistent data points should be investigated further. If it is unlikely that the data points have come from the same population as the other data (in a statistical sense), the outlying data should be eliminated from the analysis.

The single emission number for each pollutant is calculated using the following formula:

$$\text{Emission Number} = \sum (\text{Weighting Factor} \cdot \sum \text{Mean Value})$$

The results in units of gram/hr for each pollutant can then easily be compared to theoretical cumulative levels developed from the LSD-41 Class duty cycle model, the ISO derived duty cycles and the regulated limits.

## **Appendix F: Trial Report**

This Appendix is comprised of three sections: 1) the Trip report, which discusses deviations from the Test Plan (162-166), 2) sample raw data files (167-169) and 3) required supporting documentation of the testing (170-180).

## **Trip Report in Support a LSD-41 Class Amphibious Ship**

### **Main Propulsion Diesel Exhaust Emission Testing**

**General Information:** The test platform was the USS ASHLAND (LSD-41), located in Norfolk, Virginia. The testing was held in conjunction with previously scheduled sea trials to close a private contract repair availability. The dates were 14 to 16 February, 1995. The testing team consisted of representatives from the U.S. Coast Guard Research and Development Center, the NUSW, Carderock (David Taylor Research Center) Ship Testing Division, the Naval Sea Systems Engineering Station, Philadelphia Test instrumentation Division, and the Naval Engineering Graduate Office at the Massachusetts Institute of Technology.

**Ship Visits:** The first ship check was conducted in October, 1994 on a sister ship, the USS GUNSTON HALL (LSD-44). Instrumentation was selected on the basis of information gathered during this visit. A second ship check was conducted 31 January-01 February, 1995 aboard the USS ASHLAND. The fit-up of some of the instrumentation was verified during this visit and the test procedure was introduced to ship personnel.

**Installation:** The installation was accomplished in two steps. The pitot tube support fixtures were installed in both 1A and 1B MPDE Air Intake piping by NORSHIPCO, the private contractor already performing repair work on the ship under contract with Supervisor of Shipbuilding, Portsmouth (SUPSHIP Portsmouth). The contractor also installed the fitting to support the pressure tubing and thermocouple.

All other instrumentation was installed by the test team upon arrival on 12 Feb, 1995. Significant delays were encountered. Equipment which had been shipped previous to the team's arrival could not be located initially. This resulted in a half day lost effort. Additionally, the ship had not completed all main engine testing prior to the team's arrival. The installation work in the uptakes could only be accomplished on the back-shift, which proved to be very inefficient.

The result was an incomplete installation of the intake air vacuum testing system. The interface between the pressure transducer and meter/amplifier was never corrected and this reading was abandoned. The delays also precluded testing the engines inport prior to the scheduled departure from the pier. This testing was not accomplished due to lack of experience on the part of the team leader (who failed to insist on it) and a lack of energy in the test team in general. Once underway, and unable to secure the engines and enter the uptake space (due to gas-free concerns), it was discovered that the pitot tube pressure transducer for 1B MPDE was responding erratically. It was suspected that the vacuum tubes leading from the tube to the differential pressure transducer were switched, and this was verified upon returning to port. As the 1B pitot tube pressure transducer was found to be inoperable when connected in the reverse direction.

The signal from the two thermocouple assemblies were radically different during calibration. The thermocouples, with ice-point compensators, were checked using an ice bath and the voltages were satisfactory. Predicting the error lay in the amplifiers, the predicted settings were recorded to be later compared to test bench readings in the laboratory.

The calibration of only one of the ECOM instruments could be verified. The portable calibration gas cylinders held a smaller volume of gas than anticipated and the ECOM S+ was not verified. The team attempted to use the ECOM KL, the calibrated portable emissions analyzer, to the maximum extent possible.

Despite the rushed set-up, all instrumentation with the exceptions mentioned above performed superbly.

Testing: The ship had generously scheduled eighteen hours of a fifty hour sea trial to support the emissions testing. The first six hours were slotted for Blocks #1 through #3 (See Appendix E: Test Plan). MPDE 1A suffered a casualty to the lubricating oil filter canisters during the afternoon hours of 14 February; MPDE 1B became the primary test engine for the single engine per shaft testing despite concerns regarding the volumetric airflow measurement on this engine.

Blocks #1 through #3 were conducted as planned. The results were difficult to compare during collection, but it was noted upon review the next morning that the shaft torques were not kept equal during testing. The impact this would have on the results were unknown, but two additional single engine per shaft alignment runs were planned. These were to be conducted at 15 and 17 knots with particular attention paid to equalizing the load on both shafts.

Some excessive cooling of the exhaust sample lines from the probe to the portable analyzer was experienced. It was attributed to the draping of the sample tubing over ventilation ducts, which were forcing air cooling than the ambient space temperature of approximately 85° Fahrenheit into the machinery room. The sampling lines were isolated to the greatest extent possible and a decision to employ heated sample lines for all further testing was reached.

The sea conditions were perfect for the first night of testing. The winds were relatively low and sea state one was reported. The temperature was slightly above freezing and the relative humidity was moderate. All runs were conducted on

Blocks #4 through #6 required a plant alignment with two engines per shaft. This testing could not be accomplished until repairs were completed on MPDE 1A. Unfortunately, as soon as the damaged lube oil filter was replaced, a leak developed on the exhaust piping aft of the turbocharger. When this second equipment failure was finished, only two hours of the originally twelve hours of scheduled testing could be accomplished. A revised test schedule was created and is introduced as Table F-1. The priorities for the reduced test period were to recheck the 15 and 17 knot single engine per shaft readings (while MPDE 1A was being prepared for starting), and three spaced data points when both engines were online. As the ship was preparing for a graded full power trial upon completion of our testing, 24 knots was incorporated into the test plan and data was gathered throughout the run at 90% full power.

**Table F-1: Revised Test Blocks of Runs**

Block Name/Run #	Ship Speed (knots)	Propeller Pitch %	Shaft RPM
4-1-B-17*	17	100	116
4-2-B-15*	15	100	102
6-1-X-10	10	100	66
6-2-X-24	24	100	138
6-3-X-24	24	100	138
6-4-X-15	15	100	102

\* denotes single engine per shaft testing with MPDE 1B online

NOTE: X could indicate either engine 1A or 1B.

A break was taken between Run # 6-2-X and 6-3-X during the full power run to switch the ECOM units and provide comparison data between the readings from the two machines. The data collected from the ECOM KL when positioned in MPDE 1A was collected under the run name of 6-X-A-24.

The weather conditions were much rougher on the early morning of 16 February. The sea state ranged between three and four with high winds pushing on the bow. It was raining, with ambient air temperatures approximately ten degrees warmer than the previous night. The ship maneuvered extensively prior to the full power run in an attempt to create a clear, straight track for the trial. While no maneuvering was undertaken during data collection, it was difficult to predict the impact the seas would have on the propeller and engine loadings. Overall, the conditions for testing were inadequate using the requirements of the Test Plan (Appendix E).

The fifteen knot data was gathered after completion of the full power trial. At this point the ship was heading into the harbor and shallower water. This shortened the amount of data which could be collected at this operating point.

Disassembly: Nothing significant to report.

BLOCK1X.XLS

Data From Block #1 (Emissions Using ECOM KL)							
RUN 1-1-B-10							
Time	O2	CO	NOx	NO2	Stack Temp	Room Temp	
0:58:06	133	85	1499	76	519	75	
0:59:06	134	85	1482	77	521	74	
1:00:06	134	85	1469	74	522	74	
1:01:06	134	85	1466	75	525	75	
1:02:06	135	85	1474	75	528	74	
1:03:06	135	85	1459	74	529	74	
1:04:06	135	85	1437	74	530	74	
1:05:06	135	85	1459	75	533	75	
Tot/Ave	8	134.375	85	1468.125	75	525.875	74.375
Std Dev			0	18.20861	1.069045		
RUN 1-2-B-17							
Time	O2	CO	NOx	NO2	Stack Temp	Room Temp	
1:16:06	131	90	1446	67	692	76	
1:17:06	131	90	1441	66	692	75	
1:18:06	131	85	1456	68	694	75	
1:19:06	132	85	1437	67	694	76	
1:20:06	132	85	1439	67	694	75	
1:21:06	132	80	1439	68	696	76	
1:22:06	132	80	1429	67	696	75	
1:23:06	132	80	1452	67	697	75	
1:24:06	132	75	1426	67	698	75	
1:25:06	132	80	1430	66	696	75	
Tot/Ave	10	131.7	83	1439.5	67	694.9	75.3
Std Dev			4.830459	9.78945	0.666667		
RUN 1-3-B-15							
Time	O2	CO	NOx	NO2	Stack Temp	Room Temp	
1:32:06	130	110	1470	67	721	75	
1:33:06	130	110	1443	67	721	75	
1:34:06	129	110	1462	66	720	75	
1:35:06	130	115	1476	67	722	76	
1:36:06	130	110	1451	67	720	76	
1:37:06	130	110	1453	66	721	76	
1:38:06	130	110	1453	67	722	76	
Tot/Ave	7	129.8571	95	1458.286	66.71429	721	75.57143
Std dev			1.889822	11.60049	0.48795		
RUN 1-4-B-5							
Time	O2	CO	NOx	NO2	Stack Temp	Room Temp	
1:53:06	167	70	628	53	436	76	
1:54:06	167	70	631	53	431	76	
1:55:06	167	70	643	55	428	76	
1:56:06	167	70	638	55	425	76	
1:57:06	167	70	633	55	421	76	
1:58:06	167	70	633	56	418	75	

## BLOCK1X.XLS

	1:59:06	166	70	630	56	415	75
Tot/Ave	7	166.8571	70	633.7143	54.71429	424.8571	75.71429
Std Dev			0	5.154748	1.253566		
Data From Block #1 (Emissions Using ECOM KL)					Page 2		
RUN 1-5-B-0							
	Time	O2	CO	NOx	NO2	Stack Temp	Room Temp
	2:09:06	180	100	362	62	345	75
	2:10:06	180	100	359	62	343	76
	2:11:06	180	95	365	62	340	75
	2:12:06	180	95	356	62	337	76
	2:13:06	180	95	358	63	335	75
	2:14:06	180	95	363	63	333	75
	2:15:06	180	95	361	63	331	75
	2:16:06	180	95	360	64	329	75
	2:17:06	180	100	361	64	327	75
Tot/Ave	9	180	96.66667	360.5556	55.66667	335.5556	75.22222
Std Dev			2.31455	2.878492	0.744024		



REMARK	First Sample taken at:	2/15/95	1:01:48		
REMARK	Last sample was taken at:	2/15/95	1:07:32		
REMARK					
REMARK	The following is a summary of the last segment of collected data				
REMARK					
REMARK	Channel	Maximum	Minimum	Average	StDev
REMARK	1A Mn Eng RPM	6	5	5	0.12
REMARK	1B Mn Eng RPM	218	216	217	0.65
REMARK	Stbd Torque	77	75	76	0.29
REMARK	Port Torque	109	108	109	0.25
REMARK	1A Main Eng in	57	18	50	11.83
REMARK	1A Main Eng out	19	3	7	3.1
REMARK	1B Main Eng in	8	7	8	0.09
REMARK	1B Main Eng out	7	6	6	0.2
REMARK	1A Inlet Temp	255	84	104	19.67
REMARK	1B Inlet Temp	16	-11	2	6.51
REMARK	1A Delta P	1	0	0	0.01
REMARK	1B Delta P	0	0	0	0.01
REMARK	1A P Total	0	0	0	0.11
REMARK	1B P Total	0	0	0	0.02
REMARK	1A Fuel Used	54	5	43	12.39
REMARK	1B Fuel Used	2	1	1	0.23
REMARK					

**Supporting Information:**

Included are log sheets from the bridge and engineering spaces which were used during testing. The bridge logs (F- through F- ) document the sea and weather conditions hourly during testing. The engineering space logs (F- through F- ) record important engine support system conditions. The engineering rack position logs (F- through F- ) report the manual readings of each cylinder fuel rack position for each run.

The following data was gathered from engineering personnel:

**Engine Model and Serial Numbers:**

1A: Model: Fairbanks Morse PC2.5V400

Serial Number: 939745RR1

1B: Model: Fairbanks Morse PC2.5V400

Serial Number: 939745RL1

**Reduction Gear Model and Serial Numbers:**

Model: Philadelphia Gear Corporation 4-10M9X

Serial Number: 139518

Ratio: input 1200, output 99

**Draft:**

14 Feb:

Fore: 18'9" Aft: 19'9" Midship: 19'4" Displacement: 15750 ltons

15 Feb:

Fore: 19'6" Aft: 18'9" Midship: 19'1.5" Displacement: 15500 ltons

16 Feb:

Fore: 19'6" Aft: 19'0" Midship: 19'3" Displacement: 15500 ltons

**Days Since Last Hull Cleaning: 12 September, 1994**

**Injector Timing: 12° BTDC**

**Injector Size: Nozzle Tip= 55 mm**

Fuel Constituents: A fuel sample was submitted to Saybolt Labs. Table F-1 lists the results.

**Table F-2: Results of Fuel Analysis**

Constituent or Property	
Sulfur	0.38% by weight
Carbon	86.09% by weight
Hydrogen	12.97% by weight
Water & Sediment	0.025% by volume
Nitrogen	0.06% by weight
Oxygen	0.02% by weight
Ash	0.001% by weight
Specific Gravity	0.84

The stoichiometric air to fuel ratio was calculated from the values of Table F-1 and a procedure outlined in Wilcox and Babcock's text, Steam, 37<sup>th</sup> Edition. The hydrogen to carbon ratio is 1.8 and the stoichiometric air to fuel ratio is 14.38.

Bridge Watch Log		* DENOTES HEADING CHANGE									
Run Name	Speed (knots)	RPM	Pitch	Time	Relative Wind Speed (knots)	Relative Wind Direction (degrees)	Significant Wave Height (feet)	Wave Direction (degrees from)	Water Depth (fathoms)		
1-1-X-10	10	66	100	0:45	5	70	<1	340	114		
1-2-X-17	17	116	100	1:10			<1	340	765		
1-3--X-15	15	102	100	1:27	12	29	<1	340	647		
1-4--X-5	5	64	52	1:40	10	21	<1	340	693		
1-5--X-0	0	64	0	2:00	7	20	<1	340	767		
2-1-X-15	15	102	100	2:19	20	305*	<1	35	746		
2-2-X-10	10	66	100	2:41	22	305	<1	52	696		
2-3-X-0	0	64	0	3:04	14	205	<1	22	704		
2-4-X-5	5	64	52	3:22	18	108	<1	22	716		
2-5-X-17	17	116	100	3:42	17	305	<1	22	713		
3-1-X-0	0	64	0	4:00	15	0*	<1	30	727		
3-2-X-5	5	64	52	4:35	26	30	<1	30	676		
3-3-X-15	15	102	100	4:58	26	20	<1	30	690		
3-4-X-10	10	66	100	5:17	28	32	<1	30	566		
3-5-X-17	17	116	100	5:30		40	<1	30	452		

Bridge Watch Log		* Denotes Heading Change									
Run Name	Speed (knots)	RPM	Pitch	Time	Relative Wind Speed (knots)	Relative Wind Direction (degrees)	Significant Wave Height (feet)	Wave Direction (degrees from)	Water Depth (fathoms)		
4-1-X-17	17	116	100	4:22	44	320	4.5	MIXED	89		
4-2-X-15	15	102	100	4:48	46	320	4.5	MIXED	92		
6-1-X-10	10	66	100	5:03	34	320	3	MIXED	45		
6-2-X-24	24	165	100	5:32	32	350	3	MIXED	36		
6-3-X-24	24	165	100	6:09	35	5		MIXED	28		
6-4-X-24	24	165	100	6:28	45	0	3	MIXED	23		
6-5-X-15	15	102	100	6:49				MIXED			

Engineering Room Log (hourly readings)				Engine 1B
	SW Injection	Coolant	Lube Oil	Lube Oil
Time	Temp	Outlet Temp	Inlet Temp	Outlet Temp
	(Fah)	(Fah)	(Fah)	(Fah)
1:06	74	168	120	130
1:43	65	168	16	132
2:36	65	170	114	124
3:55	68	170	112	128
5:15	68	170	114	128
2/16/95				
4:48	64	180	118	120
6:02	52	170	137	112

Engineering Room Log : Rack Readings					
	Run # 1-1-B-10	Run # 1-2-B-17	Run #1-3-B-15	Run # 1-4-B-5	Run # 1-5-B-0
Eng 1B-1	13	30	24	9	7
Eng 1B-2	12	30	23	9	7
Eng 1B-3	14	31	24	10	7
Eng 1B-4	12	29	23	8	8
Eng 1B-5	13	30	24	10	7
Eng 1B-6	13	30	23	10	8
Eng 1B-7	11	28	22	7	6
Eng 1B-8	12	28	23	8	7
Eng 1B-9	13	31	25	11	9
Eng 1B-10	16	31	25	10	9
Eng 1B-11	14	29	23	10	7
Eng 1B-12	13	29	23	8	7
Eng 1B-13	13	29	23	10	8
Eng 1B-14	12	29	23	9	7
Eng 1B-15	9	26	19	5	3
Eng 1B-16	12	29	23	8	7
METER	12	27	22	7	5

Engineering Room Log : Rack Readings					
	Run # 2-1-B-15	Run # 2-2-B-10	Run # 2-3-B-0	Run # 2-4-B-5	Run # 2-5-B-17
Eng 1B-1	23	12	8	10	29
Eng 1B-2	23	13	8	10	29
Eng 1B-3	24	13	8	11	30
Eng 1B-4	22	12	6	10	29
Eng 1B-5	23	13	7	11	30
Eng 1B-6	23	13	8	11	30
Eng 1B-7	22	12	6	9	28
Eng 1B-8	23	12	7	10	29
Eng 1B-9	24	14	9	12	31
Eng 1B-10	24	14	9	12	32
Eng 1B-11	24	13	7	10	30
Eng 1B-12	22	12	6	9	30
Eng 1B-13	23	12	7	10	30
Eng 1B-14	22	12	6	9	29
Eng 1B-15	19	9	4	10	30
Eng 1B-16	22	12	7	10	29
METER	22	11	6	8	28



Engineering Room Log : Rack Readings					
	Run # 3-1-B-0	Run # 3-2-B-5	Run # 3-3-B-15	Run # 3-4-B-10	Run # 3-5-B-17
Eng 1B-1	7	9	24	12	29
Eng 1B-2	7	9	23	13	30
Eng 1B-3	8	10	24	13	30
Eng 1B-4	6	9	23	11	29
Eng 1B-5	7	10	23	13	30
Eng 1B-6	8	9	24	13	30
Eng 1B-7	6	8	22	11	28
Eng 1B-8	7	9	23	12	29
Eng 1B-9	8	10	24	14	31
Eng 1B-10	8	11	24	14	32
Eng 1B-11	7	9	23	13	30
Eng 1B-12	6	9	23	12	30
Eng 1B-13	7	9	23	13	30
Eng 1B-14	6	9	23	12	29
Eng 1B-15	8	10	24	13	30
Eng 1B-16	7	9	24	12	29
METER	5	8	22	12	28

Engineering Room Log : Rack Readings				
	Run # 4-1-B-17	Run # 4-2-B-15	Run # 6-1-B-10	Run # 6-2-B-24
Eng 1B-1	33	27	10	33
Eng 1B-2	33	28	10	33
Eng 1B-3	33	28	10	33
Eng 1B-4	32	23	10	33
Eng 1B-5	33	28	10	34
Eng 1B-6	34	28	11	35
Eng 1B-7	32	26	8	32
Eng 1B-8	33	26	9	33
Eng 1B-9	35	31	12	34
Eng 1B-10	36	29	12	36
Eng 1B-11	32	30	11	34
Eng 1B-12	32	26	9	33
Eng 1B-13	32	28	10	34
Eng 1B-14	33	26	9	33
Eng 1B-15	33	27	10	35
Eng 1B-16	33	26	9	34
METER	32	27	9	33



Institute Archives and Special Collections  
Room 14N-118  
The Libraries  
Massachusetts Institute of Technology  
Cambridge, Massachusetts 02139-4307

**This is the most complete text of the thesis available. The following page(s) were not included in the copy of the thesis deposited in the Institute Archives by the author: 179**

Engineering Room Log : Rack Readings		
	Run # 6-1-A-10	Run # 6-2-A-24
Eng 1A-1	9	33
Eng 1A-2	10	33
Eng 1A-3	11	34
Eng 1A-4	11	33
Eng 1A-5	10	34
Eng 1A-6	11	34
Eng 1A-7	8	32
Eng 1A-8	11	33
Eng 1A-9	10	33
Eng 1A-10	12	34
Eng 1A-11	10	33
Eng 1A-12	10	33
Eng 1A-13	11	33
Eng 1A-14	10	33
Eng 1A-15	10	32
Eng 1A-16	10	34
METER	8	33

## **Appendix G: LSD-48 Emissions Measurement Results**

Samples of the raw data collected during the emissions testing of the USS ASHLAND on 15 and 16 February, 1995, was introduced in Appendix F. The manipulation of this data in order to present it in a meaningful form is documented in this appendix. Spreadsheets of results are followed by documentation listing the applied equations. Data sheets (G-2 through G-12) are included for:

- 1) calculation of the ambient and local (in vicinity of pitot tube located in uptake piping) temperature, humidity and pressure conditions.
- 2) computation of exhaust mass flow rate
- 3) computation of mass specific and power specific emission levels
- 4) sensitivity checks of the exhaust mass flow rate to small variations in the input data

Additionally, additional plots are included to support discussion of the variations in the measured emissions data and the effect of these variations on the results presented in Chapter 5.

Table G-1: Partial Pressure and Absolute Humidity Calculations												
Time	Barometer (in Hg)	Bridge Pressure psi	Uptake Pressure psi	Relative Humidity (%)	Dry Bulb Temp (F)	Dry Bulb Temp (C)	Sat Pressure (bar)	Sat Pressure (psi)	Partial Press (psi)	Abs Humidity (lb H <sub>2</sub> O/lb air)	Dry Air Density (lb/ft <sup>3</sup> )	
15-Feb												
0:49	30.7600	14.8719	15.0173	50.0000	47.5000	8.6111	0.0112	0.1623	0.0812	0.0034	0.0795	
1:03	30.7600	14.8719	15.0173	47.5000	43.0000	6.1111	0.0094	0.1367	0.0649	0.0027	0.0786	
1:52	30.7800	14.8816	15.0270	47.5000	42.0000	5.5556	0.0091	0.1316	0.0625	0.0026	0.0787	
2:47	30.7600	14.8719	15.0173	46.5000	42.0000	5.5556	0.0087	0.1264	0.0588	0.0024	0.0787	
3:43	30.7700	14.8767	15.0222	46.5000	42.0000	5.5556	0.0087	0.1264	0.0588	0.0024	0.0787	
4:38	30.7800	14.8816	15.0270	47.0000	42.5000	5.8333	0.0092	0.1340	0.0630	0.0026	0.0786	
5:35	30.7600	14.8719	15.0173	46.5000	42.0000	5.5556	0.0087	0.1264	0.0588	0.0024	0.0787	
MAX		14.8816	15.0270	50.0000		8.6111		0.1623	0.0812	0.0034	0.0795	
MIN		14.8719	15.0173	46.5000		5.5556		0.1264	0.0588	0.0024	0.0786	
STD DEV		0.0046	0.0046	1.2488		1.1226		0.0128	0.0080	0.0003	0.0003	
AVERAGE		14.8753	15.0208	47.3571		6.1111		0.1348	0.0640	0.0027	0.0788	
16-Feb												
4:22	29.8400	14.4271	14.5725	100.0000	52.0000	11.1111	0.0132	0.1917	0.1917	0.0083	0.0765	
5:03	29.8900	14.4513	14.5967	100.0000	50.0000	10.0000	0.0123	0.1781	0.1781	0.0077	0.0769	
5:32	29.8900	14.4513	14.5967	100.0000	49.0000	9.4444	0.0118	0.1717	0.1717	0.0074	0.0771	
5:43	29.8900	14.4513	14.5967	100.0000	47.0000	8.3333	0.0110	0.1592	0.1592	0.0069	0.0774	
MAX		14.4513	14.5967	100.0000		11.1111		0.1917	0.1917	0.0083	0.0774	
MIN		14.4271	14.5725	100.0000		8.3333		0.1592	0.1592	0.0069	0.0765	
STD DEV		0.0121	0.0121	0.0000		1.1565		0.0135	0.0135	0.0006	0.0004	
AVERAGE		14.4452	14.5907	100.0000		9.7222		0.1752	0.1752	0.0076	0.0770	

### Partial Pressure and Absolute Humidity Calculations:

The barometric pressure was measured on the bridge on an hourly basis. The pressure deviation due to the height difference between the bridge and location of the pitot tube in the air intake piping of the uptake room was accounted for using equation (G-1):

$$P_{uptake} = P_{bridge} + \rho_{air} * g * h \quad (G-1)$$

where the density of the air as a function of the bridge temperature was used and the height "h" was 60 feet.

The relative humidity and bridge dry bulb temperature was measured directly on the bridgework. The saturation pressure was determined selected from a table<sup>1</sup> as a function of air temperature. The partial pressure, absolute humidity and dry air density were then computed using equations (16) through 18).

---

<sup>1</sup> Wark, Kenneth, Thermodynamics, Fourth Edition, McGraw-Hill Publishers, 1983, p.799.

Table G-2: Temperature Calculations									
1A Calibration Constants		(mV)		1A Inlet Temp		1A Calibration Constants		1B Inlet Temp	
zero=	-1.67	slope=	0.0597	slope=	1000	zero=	-1.7	slope=	1000
slope=	0.0597	zero=	-158	zero=	-158	slope=	0.0607	zero=	16.2
Run #	Speed (knts)	millivolts	raw data (mV)	Temp (C)	Run #	Speed (knts)	millivolts	raw data (mV)	Temp (C)
1-5-B-0	0				1-5-B-0	0	6.44	-0.00976	27.8458
2-3-B-0	0				2-3-B-0	0	2.197	-0.014003	27.7759
3-1-B-0	0				3-1-B-0	0	4.084	-0.012116	27.80699
1-4-B-5	5				1-4-B-5	5	3	-0.0132	27.78913
2-4-B-5	5				2-4-B-5	5	6.83	-0.00937	27.85222
3-2-B	5				3-2-B	5	3.273	-0.012927	27.79362
1-1-B-10	10				1-1-B-10	10	2	-0.0142	27.77265
2-2-B-10	10				2-2-B-10	10	3	-0.0132	27.78913
3-4-B-10	10				3-4-B-10	10	2.848	-0.013352	27.78662
1-3-B-15	15				1-3-B-15	15	5	-0.0112	27.82208
2-1-B	15				2-1-B-15	15	4	-0.0122	27.8056
3-3-B	15				3-3-B	15	3.095	-0.013105	27.79069
4-2-B-15	15				4-2-B-15	15	3.463	-0.012737	27.79675
1-2-B-17	17				1-2-B-17	17	3	-0.0132	27.78913
2-5-B-17	17				2-5-B-17	17	2.952	-0.013248	27.78834
3-5-B-17	17				3-5-B-17	17	2.339	-0.013861	27.77824
4-1-B	17				4-1-B-17	17	3	-0.0132	27.78913
6-1-X	10	-275.941	-0.117941	25.99764	6-1-X	10	2.412	-0.013788	27.77944
6-2-X	24	-564.424	-0.406424	21.16543	6-2-X	24	3.549	-0.012651	27.79817
6-3-X	24	-574.006	-0.416006	21.00492	6-3-X	24	3.045	-0.013155	27.78987
6-X-24	24	-589.971	-0.431971	20.7375					
6-4-X	15	-562.29	-0.40429	21.20117	6-4-X	17	1.5625	-0.0146375	27.76544



Intake Air Temperature Calculations:

As discussed in Appendix F, the calibration of the ECTRON amplifiers used to amplify the thermocouple assemblies was not known. The calibration curves introduced in Appendix F were applied and the temperature of the intake air was found. This temperature matched the machinery space temperature, an anticipated result.

The incorrect slope and zero were removed and the correct calibration constants were introduced using the same equation.

$$Temperature = \frac{(milliVolt - Zero)}{slope} \quad (G-2)$$

Table G-3: Summary Data From Sea Trials													
Run #	Ship Speed (knots)	1A Engine		1B Engine		1A Engine		1B Engine		1A Engine		1B Engine	
		RPM	Torque (1000 ft.-lbs)	RPM	Torque (1000 ft.-lbs)	Power (BHP)	Fuel Used (GPM)	Power (BHP)	Fuel Used (GPM)	Power (BHP)	Fuel Used (GPM)	Power (BHP)	Fuel Used (GPM)
1-5-B	0*	221	13	13,38826*	178,7617*	0.4269*	181,245	2008,751	181,245	0.4269*	181,245	2008,751	15.02079
2-3-B	0*	221.4	13.16*	13,553038*	181,2893*	0.428385*	181,8755	2013,754	181,8755	0.428385*	181,8755	2013,754	15.02079
3-1-B	0*	221.83	13.049*	13,438723*	180,1093*	0.427692*	181,5812	2011,419	181,5812	0.427692*	181,5812	2011,419	15.02079
Ave		221.41	13.069667	13,460007	180,0534	0.427659	181,5672	2011,309	181,5672	0.427659	181,5672	2011,309	15.02079
1-4-B	5*	220	32*	32,955716*	438,0376*	0.581549*	246,9029	2504,889	246,9029	0.581549*	246,9029	2504,889	15.02079
2-4-B	5*	219.97	39.35*	40,525232*	538,5759*	0.642775*	272,9973	2688,6	272,9973	0.642775*	272,9973	2688,6	15.02079
3-2-B	5*	220.53	34.64*	35,674562*	475,318*	0.60417*	256,507	2573,545	256,507	0.60417*	256,507	2573,545	15.02079
Ave		220.1667	35.33	36,38517	483,9772	0.609438	258,7436	2589,4	258,7436	0.609438	258,7436	2589,4	15.02079
1-1-B	10*	217	76*	78,269825*	1026,153*	0.949682*	403,1978	3521,765	403,1978	0.949682*	403,1978	3521,765	15.02079
2-2-B	10*	217	72*	74,15036*	972,1448*	0.914872*	388,4186	3433,629	388,4186	0.914872*	388,4186	3433,629	15.02079
3-4-B	10*	216.87	74.66*	76,889804*	1007,456*	0.937608*	398,0718	3491,357	398,0718	0.937608*	398,0718	3491,357	15.02079
Ave		216.9567	74.22	76,436663	1001,918	0.934036	396,5553	3482,329	396,5553	0.934036	396,5553	3482,329	15.02079
1-3-B	15*	330	163*	167,86818*	3346,881*	2.637273*	1119,683	7031,211	1119,683	2.637273*	1119,683	7031,211	15.02079
2-1-B	15*	328	161*	165,80844*	3285,78*	2.598036*	1096,779	6931,332	1096,779	2.598036*	1096,779	6931,332	15.02079
3-3-B	15*	327.2	164.88*	168,80433*	3356,758*	2.645256*	1123,072	7047,468	1123,072	2.645256*	1123,072	7047,468	15.02079
4-2-B	15*	329.85	196.1*	201,95675*	4024,694*	3.200895*	1358,975	8234,207	1358,975	3.200895*	1358,975	8234,207	14.59067
Ave		328.7625	171.245	176,35942	3503,528	2.764689	1173,779	7292,94	1173,779	2.764689	1173,779	7292,94	14.91326
1-2-B	17*	364	215*	221,42122*	4869,435*	3.948082*	1676,201	10069,54	1676,201	3.948082*	1676,201	10069,54	15.02079
2-5-B	17*	362.09	216.99*	223,47065*	4898,718*	3.965718*	1683,688	10116,95	1683,688	3.965718*	1683,688	10116,95	15.02079
3-5-B	17*	363.6	217.5*	223,99588*	4920,643*	3.994973*	1696,109	10196,05	1696,109	3.994973*	1696,109	10196,05	15.02079
4-1-B	17*	366.94	244.28*	251,5757*	5577,271*	4.612417*	1958,252	12005,37	1958,252	4.612417*	1958,252	12005,37	14.59067
Ave		364.1575	223.4425	230,11586	5084,017	4.12723	1752,26	10560,84	1752,26	4.12723	1752,26	10560,84	14.91326
6-1-X	10	218.96	89.716	46,197734	611,1438	0.687405	291,8454	2829,547	291,8454	0.687405	291,8454	2829,547	15.02079
6-2-X	24	522.296	460.923	237,34449	7489,517	6.581504	2794,249	20309,61	2794,249	6.581504	2794,249	20309,61	15.02079
6-3-X	24	522.594	468.469	241,23018	7616,475	6.721245	2895,578	21017,91	2895,578	6.721245	2895,578	21017,91	15.02079
6-x-A	24	522.235	472.818	243,46962	7681,901	6.793697	2884,338	20883,09	2884,338	6.793697	2884,338	20883,09	15.02079
6-4-X	15	329.86	211.58	108,94954	2171,266	1.735539	736,8418	5386,786	736,8418	1.735539	736,8418	5386,786	15.02079
Ship Speed (knots)													
Run #													

Partial Water Pressure (psi)	1A Uptake		1B Uptake		1A Uptake		1B Uptake		1A Uptake		1B Uptake		1A Uptake		1B Uptake		1A Uptake		1B Uptake		1A Uptake		1B Uptake		
	Temp (C)	Temp (F)	Temp (C)	Temp (F)	Air Density (lbs/ft <sup>3</sup> )	Air Density (lbs/ft <sup>3</sup> )	Air Density (lbs/ft <sup>3</sup> )	Air Density (lbs/ft <sup>3</sup> )	Air Density (lbs/ft <sup>3</sup> )	Air Density (lbs/ft <sup>3</sup> )	Air Density (lbs/ft <sup>3</sup> )	Air Density (lbs/ft <sup>3</sup> )	Air Density (lbs/ft <sup>3</sup> )	Air Density (lbs/ft <sup>3</sup> )	Air Density (lbs/ft <sup>3</sup> )	Air Density (lbs/ft <sup>3</sup> )	Air Density (lbs/ft <sup>3</sup> )	Air Density (lbs/ft <sup>3</sup> )	Air Density (lbs/ft <sup>3</sup> )	Air Density (lbs/ft <sup>3</sup> )	Air Density (lbs/ft <sup>3</sup> )	Air Density (lbs/ft <sup>3</sup> )	Air Density (lbs/ft <sup>3</sup> )	Air Density (lbs/ft <sup>3</sup> )	
0.064			27.8458	82.12244	0.0744886	0.0744886	8977.75	49.53377	0.002660332	0	10.83165	0	10.83165	0.002660332	0	10.83165	0.002660332	0	10.83165	0.002660332	0	10.83165	0.002660332	0	10.83165
0.064			27.7759	81.99662	0.0745059	0.0745059	9002.199	49.49648	0.002660332	0	10.86115	0	10.86115	0.002660332	0	10.86115	0.002660332	0	10.86115	0.002660332	0	10.86115	0.002660332	0	10.86115
0.064			27.807	82.05257	0.0744982	0.0744982	8990.832	49.51412	0.002660332	0	10.84744	0	10.84744	0.002660332	0	10.84744	0.002660332	0	10.84744	0.002660332	0	10.84744	0.002660332	0	10.84744
0.064			27.8096	82.05721	0.0744976	0.0744976	8990.261	49.51479	0.002660332		10.84675		10.84675	0.002660332		10.84675	0.002660332		10.84675	0.002660332		10.84675	0.002660332		10.84675
0.064			27.7891	82.02043	0.0745027	0.0745027	11197.26	45.35084	0.002660332		13.50949		13.50949	0.002660332		13.50949	0.002660332		13.50949	0.002660332		13.50949	0.002660332		13.50949
0.064			27.8522	82.134	0.0744871	0.0744871	12015.96	44.03106	0.002660332		14.49725		14.49725	0.002660332		14.49725	0.002660332		14.49725	0.002660332		14.49725	0.002660332		14.49725
0.064			27.7936	82.02852	0.0745016	0.0745016	11503.98	44.84862	0.002660332		13.87956		13.87956	0.002660332		13.87956	0.002660332		13.87956	0.002660332		13.87956	0.002660332		13.87956
0.064			27.8117	82.06099	0.0744971	0.0744971	11572.4	44.74351	0.002660332		13.9621		13.9621	0.002660332		13.9621	0.002660332		13.9621	0.002660332		13.9621	0.002660332		13.9621
0.064			27.7727	81.99077	0.0745067	0.0745067	15743.71	39.04712	0.002660332		18.99479		18.99479	0.002660332		18.99479	0.002660332		18.99479	0.002660332		18.99479	0.002660332		18.99479
0.064			27.7891	82.02043	0.0745027	0.0745027	15348.87	39.51631	0.002660332		18.51841		18.51841	0.002660332		18.51841	0.002660332		18.51841	0.002660332		18.51841	0.002660332		18.51841
0.064			27.7866	82.01592	0.0745033	0.0745033	15607.05	39.20663	0.002660332		18.82991		18.82991	0.002660332		18.82991	0.002660332		18.82991	0.002660332		18.82991	0.002660332		18.82991
0.064			27.7828	82.00904	0.0745042	0.0745042	15566.55	39.25669	0.002660332		18.78104		18.78104	0.002660332		18.78104	0.002660332		18.78104	0.002660332		18.78104	0.002660332		18.78104
0.064			27.8221	82.07974	0.0744945	0.0744945	31427.2	28.06795	0.002660332		37.91691		37.91691	0.002660332		37.91691	0.002660332		37.91691	0.002660332		37.91691	0.002660332		37.91691
0.064			27.8056	82.05008	0.0744986	0.0744986	30982.47	28.19718	0.002660332		37.38034		37.38034	0.002660332		37.38034	0.002660332		37.38034	0.002660332		37.38034	0.002660332		37.38034
0.064			27.7907	82.02325	0.0745023	0.0745023	31503.14	28.05086	0.002660332		38.00854		38.00854	0.002660332		38.00854	0.002660332		38.00854	0.002660332		38.00854	0.002660332		38.00854
0.175			27.968	82.03416	0.0718046	0.0718046	35475.22	26.10441	0.007555327		121.5542		121.5542	0.007555327		121.5542	0.007555327		121.5542	0.007555327		121.5542	0.007555327		121.5542
0.092			27.8038	82.04681	0.0738293	0.0738293	32347.01	27.6051	0.003884081		58.71499		58.71499	0.003884081		58.71499	0.003884081		58.71499	0.003884081		58.71499	0.003884081		58.71499
0.064			27.7891	82.02043	0.0745027	0.0745027	45012.45	26.85385	0.002660332		54.30751		54.30751	0.002660332		54.30751	0.002660332		54.30751	0.002660332		54.30751	0.002660332		54.30751
0.064			27.7883	82.019	0.0745029	0.0745029	45224.5	26.86037	0.002660332		54.56335		54.56335	0.002660332		54.56335	0.002660332		54.56335	0.002660332		54.56335	0.002660332		54.56335
0.064			27.7782	82.00083	0.0745054	0.0745054	45579.61	26.87305	0.002660332		54.9918		54.9918	0.002660332		54.9918	0.002660332		54.9918	0.002660332		54.9918	0.002660332		54.9918
0.175			27.7891	82.02043	0.0718064	0.0718064	51723.72	26.41321	0.007555327		177.2289		177.2289	0.007555327		177.2289	0.007555327		177.2289	0.007555327		177.2289	0.007555327		177.2289
0.092			27.7862	82.01517	0.0738293	0.0738293	46885.07	26.75012	0.003884081		85.27288		85.27288	0.003884081		85.27288	0.003884081		85.27288	0.003884081		85.27288	0.003884081		85.27288
0.175	25.9976	78.79575	27.7794	82.00299	0.0743915	0.0743915	12580.061	42.77808	0.007555327	43.10522	43.10497613	43.10497613	43.10497613	0.007555327	43.10497613	43.10497613	0.007555327	43.10497613	43.10497613	0.007555327	43.10497613	43.10497613	0.007555327	43.10497613	43.10497613
0.175	21.1654	70.09777	27.7982	82.03671	0.0756121	0.0756121	89981.402	31.77871	0.007555327	32.20236	32.20236	32.20236	32.20236	0.007555327	32.20236	32.20236	0.007555327	32.20236	32.20236	0.007555327	32.20236	32.20236	0.007555327	32.20236	32.20236
0.175	21.0049	69.80886	27.7899	82.02176	0.0756534	0.0756534	93145.248	32.64157	0.007555327	32.64157	32.64157	32.64157	32.64157	0.007555327	32.64157	32.64157	0.007555327	32.64157	32.64157	0.007555327	32.64157	32.64157	0.007555327	32.64157	32.64157
0.175	20.7375	69.32751			0.0757222	0.0757222	94878.782			32.89448		32.89448			32.89448				32.89448			32.89448			32.89448
0.175	21.2012	70.16211	27.7654	81.9778	0.075603	0.075603	23807.252	31.18911	0.007555327	32.30985	32.30985	32.30985	32.30985	0.007555327	32.30985	32.30985	0.007555327	32.30985	32.30985	0.007555327	32.30985	32.30985	0.007555327	32.30985	32.30985
Water Pressure (psi)	1A Temp (C)	1A Temp (F)	1B Temp (C)	1B Temp (F)	Air Density (lbs/ft <sup>3</sup> )	Air Density (lbs/ft <sup>3</sup> )	1A Temp (C)	1A Temp (F)	Air Density (lbs/ft <sup>3</sup> )	Air Density (lbs/ft <sup>3</sup> )	1A Temp (C)	1A Temp (F)	Air Density (lbs/ft <sup>3</sup> )	Air Density (lbs/ft <sup>3</sup> )	1A Temp (C)	1A Temp (F)	Air Density (lbs/ft <sup>3</sup> )	Air Density (lbs/ft <sup>3</sup> )	1A Temp (C)	1A Temp (F)	Air Density (lbs/ft <sup>3</sup> )	Air Density (lbs/ft <sup>3</sup> )	1A Temp (C)	1A Temp (F)	Air Density (lbs/ft <sup>3</sup> )

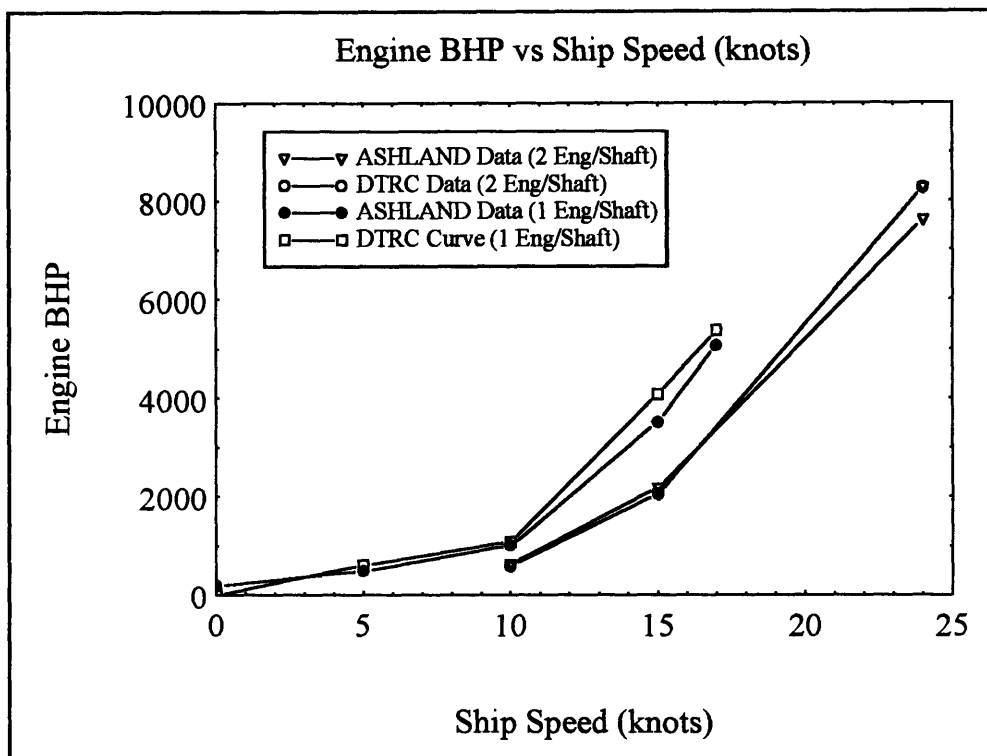
Exhaust Mass Flow Rate Calculation:

The engine RPM, shaft torque and fuel consumption were data input from trial measurements. The engine power is computed from equation (G-3):

$$BHP = \frac{RPM \cdot Torque \text{ (lbf-ft)}}{5252 \cdot Number \text{ of Engines Online}} \quad (G-3)$$

Figure G-1 plots the calculated engine load against data measured during the Standardization Trial. The correlation between the data sets is high.

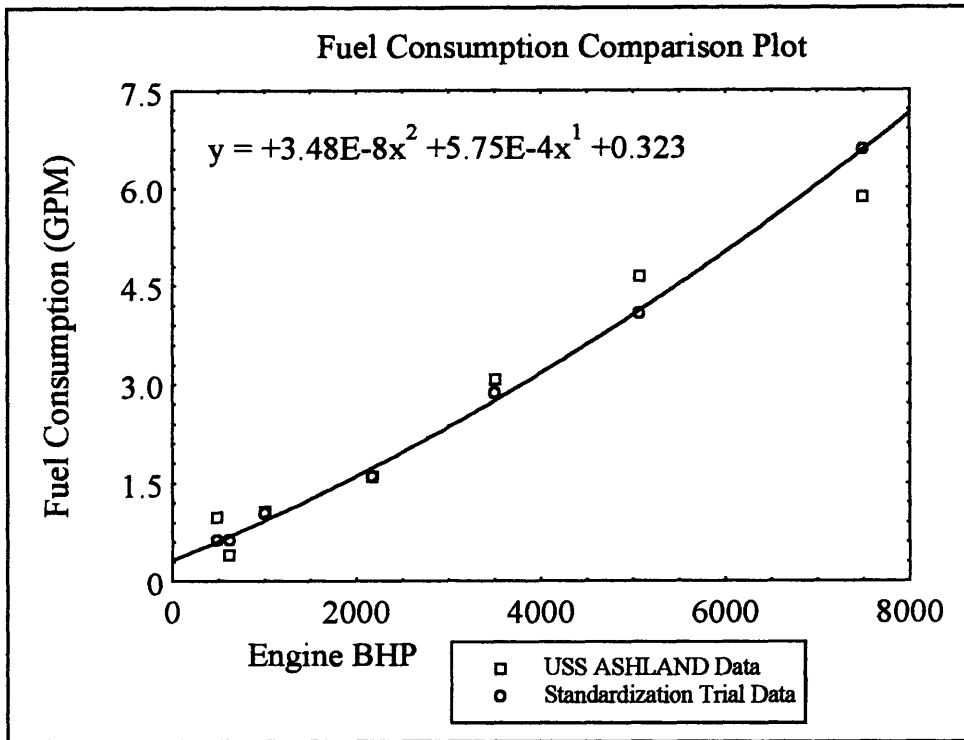
**Figure G-1: Engine BHP Correlation**



A best fit curve was plotted through available fuel and air volumetric flow rate data to allow calculation of these values as a function of the engine BHP. The equation and curve for the volumetric air flow is included as Figure 28 in Chapter 5. Figure G-2 depicts the volumetric fuel flow rate and the curve follows equation (G-4):

$$Fuel \text{ Flow Rate (GPM)} = -3.48E-8 \cdot BHP^2 + 5.75E-4 \cdot BHP + 0.323 \quad (G-4)$$

**Figure G-2: Volumetric Fuel Flow Rate versus Engine Load**



Equations (19) through (22) of Chapter 5 were used for calculation of all other terms.

The calculation of the specific emissions, G-9 and G-10, were computed using equation (23) and (24).

Table G-4: Calculation of Specific Emissions								
Engine #	Run #	Ship Speed knots	Power bhp	mexhaust kg/hr	H2O mol conc	CO dry mol conc	CO wet mol conc	CO wet ppm
1B	1-5-B	0	178.7617	9169.827	0.019862	0.000117	0.000114	114.3498
1B	2-3-B	0	181.2893	9194.936	0.022178	0.000126	0.000123	123.0426
1B	3-1-B	0	180.1093	9183.261	0.017894	0.000135	0.000133	132.5843
Ave			180.0534	9182.675	0.019978	0.000126		
1B	1-4-B	5	438.0376	11457.67	0.028517	0.00009	8.74E-05	87.43344
1B	2-4-B	5	538.5759	12303.35	0.032668	8.86E-05	8.57E-05	85.67661
1B	3-2-B	5	475.318	11774.37	0.028429	9.57E-05	9.3E-05	92.99298
Ave			483.9772	11845.13	0.029871	9.14E-05		
1B	1-1-B	10	1026.153	16165.91	0.049967	0.000105	9.98E-05	99.75345
1B	2-2-B	10	972.1448	15755.81	0.046896	7.56E-05	7.21E-05	72.07851
1B	3-4-B	10	1007.456	16023.96	0.040691	0.000075	7.19E-05	71.94815
Ave			1001.918	15981.89	0.045851	8.52E-05		
1B	1-3-B	15	3346.881	32584.8	0.052946	0.000115	0.000109	108.9112
1B	2-1-B	15	3285.78	32118.63	0.053528	0.000126	0.000119	119.0977
1B	3-3-B	15	3356.758	32664.22	0.048409	0.00012	0.000114	114.1909
1B	4-2-B	15	4024.694	36955.75	0.052054	0.000143	0.000135	135.0823
Ave			3503.528	33580.85	0.051734	0.000126		
1B	1-2-B	17	4869.435	46742.96	0.051731	0.000103	9.77E-05	97.67167
1B	2-5-B	17	4888.718	46962.75	0.05053	8.25E-05	7.83E-05	78.33126
1B	3-5-B	17	4920.643	47330.72	0.046769	8.39E-05	8E-05	79.9655
1B	4-1-B	17	5577.271	53859.2	0.052199	0.000111	0.000106	105.6121
Ave			5064.017	48723.91	0.050307	9.52E-05		
1A	6-1-X	10	611.1438	12915.01	0.034281	8.57E-05	8.28E-05	82.77567
1B	6-1-X	10	617.4127	12891.43	0.031425	6.43E-05	6.23E-05	62.26554
1A	6-2-X	24	7489.517	93083.97	0.049441	8.03E-05	7.63E-05	76.30876
1B	6-2-X	24	7577.978	93254.02	0.050104	4.58E-05	4.35E-05	43.53687
1A	6-3-X	24	7616.475	96317.98	0.050016	0.000084	7.98E-05	79.79866
1B	6-3-X	24	7705.918	96470.1	0.04959	0.000075	7.13E-05	71.28074
1A	6-X-24	24	7681.901	98088.22	0.049133	0.000103	9.77E-05	97.67967
1A	6-4-X	15	2171.266	24625.67	0.053078	9.33E-05	8.84E-05	88.37909
1B	6-4-X	15	2266.645	24750.99	0.050703	0.000095	9.02E-05	90.1832
Engine #	Run #	Ship Speed knots	Power bhp	mexhaust kg/hr	H2O mol conc	CO dry mol conc	CO wet mol conc	CO wet ppm

u(CO)	CO	NO	NO2	NOX	NOx wet	NOx wet	u(NOx)	NOx
gCO/KG exhaust	g/hp-hr	mol conc	mol conc	mol conc	mol conc	ppm		g/hp-hr
0.000966141	5.66712	0.000336	0.000101	0.000436	0.000428	427.5656	0.00109	23.91437
0.000966141	6.029375	0.000381	0.000109	0.00049	0.000479	479.2961	0.00109	26.50634
0.000966141	6.531205	0.000278	0.000107	0.000385	0.000378	377.7868	0.00109	21.00279
	6.0759	0.000331	0.000106	0.000437				23.80783
0.000966141	2.209545	0.000609	9.97E-05	0.000708	0.000688	688.2216	0.00109	19.62829
0.000966141	1.890946	0.000744	0.000108	0.000851	0.000824	823.5479	0.00109	20.51326
0.000966141	2.225584	0.000629	0.000112	0.000742	0.00072	720.4882	0.00109	19.46031
	2.108692	0.000661	0.000106	0.000767				19.86729
0.000966141	1.518296	0.001443	0.00012	0.001563	0.001485	1485.02	0.00109	25.50879
0.000966141	1.128641	0.001345	0.000119	0.001464	0.001395	1395.106	0.00109	24.65395
0.000966141	1.105614	0.001216	0.000112	0.001328	0.001274	1273.981	0.00109	22.09408
	1.25085	0.001334	0.000117	0.001452				24.08561
0.000966141	1.024443	0.001433	0.000112	0.001545	0.001463	1463.199	0.00109	15.53272
0.000966141	1.124766	0.001345	0.000119	0.001464	0.001385	1385.398	0.00109	14.76599
0.000966141	1.073555	0.00133	0.000101	0.001431	0.001362	1361.726	0.00109	14.44813
0.000966141	1.198363	0.001231	9.21E-05	0.001323	0.001254	1254.488	0.00109	12.55988
	1.105282	0.001335	0.000106	0.001441				14.32668
0.000966141	0.90583	0.001415	0.000112	0.001527	0.001448	1447.532	0.00109	15.15079
0.000966141	0.726999	0.001358	0.00011	0.001469	0.001394	1394.451	0.00109	14.606
0.000966141	0.743129	0.001281	0.000106	0.001387	0.001322	1322.343	0.00109	13.86867
0.000966141	0.985354	0.001218	9.13E-05	0.001309	0.001241	1240.53	0.00109	13.06215
	0.840328	0.001318	0.000105	0.001423				14.1719
0.000966141	1.69003	0.00072	0.000104	0.000825	0.000796	796.3041	0.00109	18.34847
0.000966141	1.25607	0.000658	8.69E-05	0.000745	0.000721	721.4501	0.00109	16.42484
0.000966141	0.916296	0.000781	5.57E-05	0.000837	0.000796	795.5123	0.00109	10.78046
0.000966141	0.517621	0.001027	7.83E-05	0.001105	0.00105	1049.583	0.00109	14.08317
0.000966141	0.974966	0.000782	6.03E-05	0.000842	0.0008	800.1715	0.00109	11.03331
0.000966141	0.862146	0.001014	0.000075	0.001089	0.001035	1035.31	0.00109	14.13215
0.000966141	1.205016	0.000893	0.000022	0.000915	0.00087	869.7836	0.00109	12.10957
0.000966141	0.968423	0.001164	8.37E-05	0.001247	0.001181	1181.131	0.00109	14.60638
0.000966141	0.951426	0.001337	9.65E-05	0.001433	0.00136	1360.342	0.00109	16.19671
u(CO)	CO	NO	NO2	NOX	NOx wet	NOx wet	u(NOx)	NOx
gCO/KG exhaust	g/hp-hr	mol conc	mol conc	mol conc	mol conc	ppm		g/hp-hr

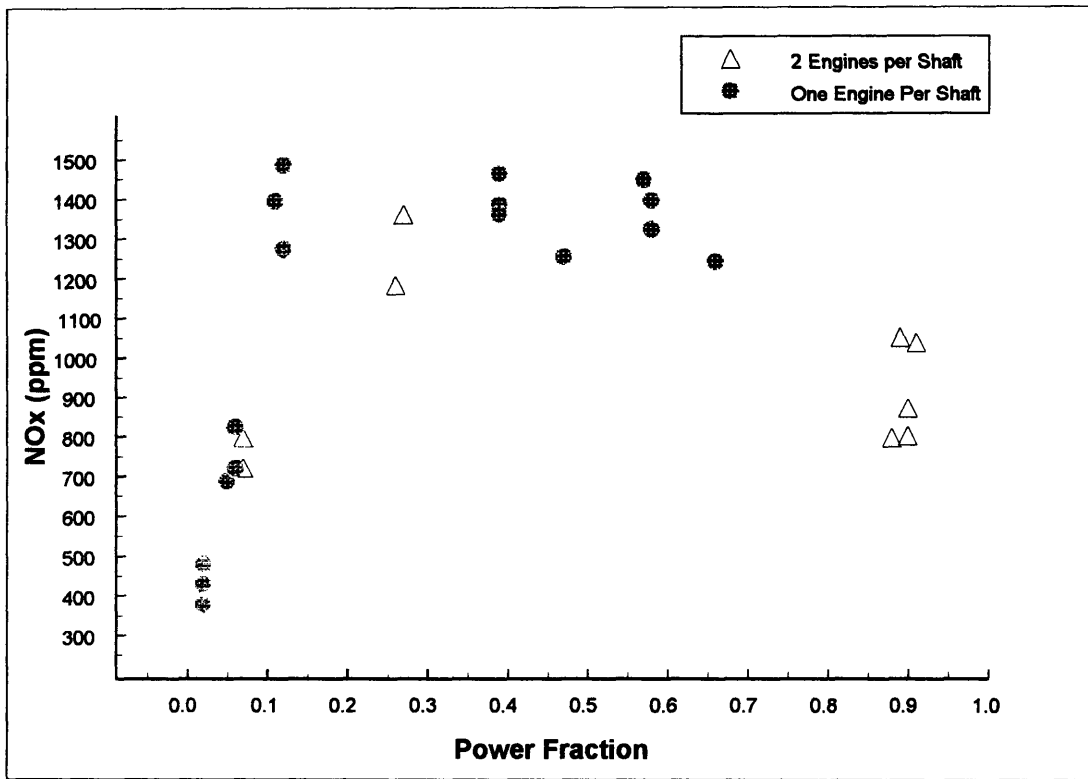
Table G-5: Comparison of Exhaust Flow Rates Due to Variations in the Input Data									
Original 1A	Original 1B	High End 1A	High End 1B	1A % Difference	1B % Difference	Low End 1A	Low End 1B	1A % Difference	1B % Difference
mexhaust kg/hr	mexhaust kg/hr	mxhaust kg/hr	mexhaust kg/hr			mxhaust kg/hr	mexhaust kg/hr		
	9169.827		9167.861		0.021443		9174.195		-0.047637
	9194.936		9191.456		0.037848		9198.419		-0.037878
	9183.261		9180.366		0.031521		9186.157		-0.031542
	9182.675		9179.894		0.030278		9186.257		-0.039014
	11457.67		11453.16		0.03933		11462.18		-0.039361
	12303.35		12300.77		0.020999		12310.59		-0.058832
	11774.37		11770.24		0.035095		11778.51		-0.03512
	11845.13		11841.39		0.03158		11850.42		-0.044697
	16165.91		16160.29		0.034718		16171.52		-0.034742
	15755.81		15749.4		0.040644		15762.22		-0.040678
	16023.96		16018.27		0.035466		16029.64		-0.035492
	15981.89		15975.99		0.036915		15987.79		-0.036943
	32584.8		32574.25		0.032371		32595.35		-0.032392
	32118.63		32104.11		0.045206		32133.16		-0.045249
	32664.22		32649.56		0.044884		32678.9		-0.044925
	36955.75		36942.96		0.034609		36968.55		-0.034634
	33580.85		33567.72		0.039099		33593.99		-0.039131
	46742.96		46724.94		0.038544		46760.99		-0.038574
	46962.75		46944.2		0.039493		46981.31		-0.039525
	47330.72		47312.52		0.038441		47348.92		-0.038471
	53859.2		53839.82		0.035995		53878.6		-0.036022
	48723.91		48705.37		0.038043		48742.46		-0.038073
12915.01	12891.43	12891.93	12887.33	0.178689	0.031802	12938.17	12895.53	-0.179345	-0.031823
93083.97	93254.02	93004.95	93223.9	0.084888	0.032294	93163.12	93284.15	-0.085037	-0.032315
96317.98	96470.1	96219.47	96446.15	0.102275	0.024829	96416.7	96494.07	-0.102491	-0.024842
98088.22		98069.73		0.018849		98106.71		-0.018856	
24625.67	24750.99	24615.32	24741.63	0.04201	0.037786	24636.03	24760.35	-0.042068	-0.037821
Original 1B	High End 1A	High End 1B	1A % Difference	1B % Difference	Low End 1A	Low End 1B	1A % Difference	1B % Difference	
mexhaust kg/hr	mxhaust kg/hr	mexhaust kg/hr			mxhaust kg/hr	mexhaust kg/hr			



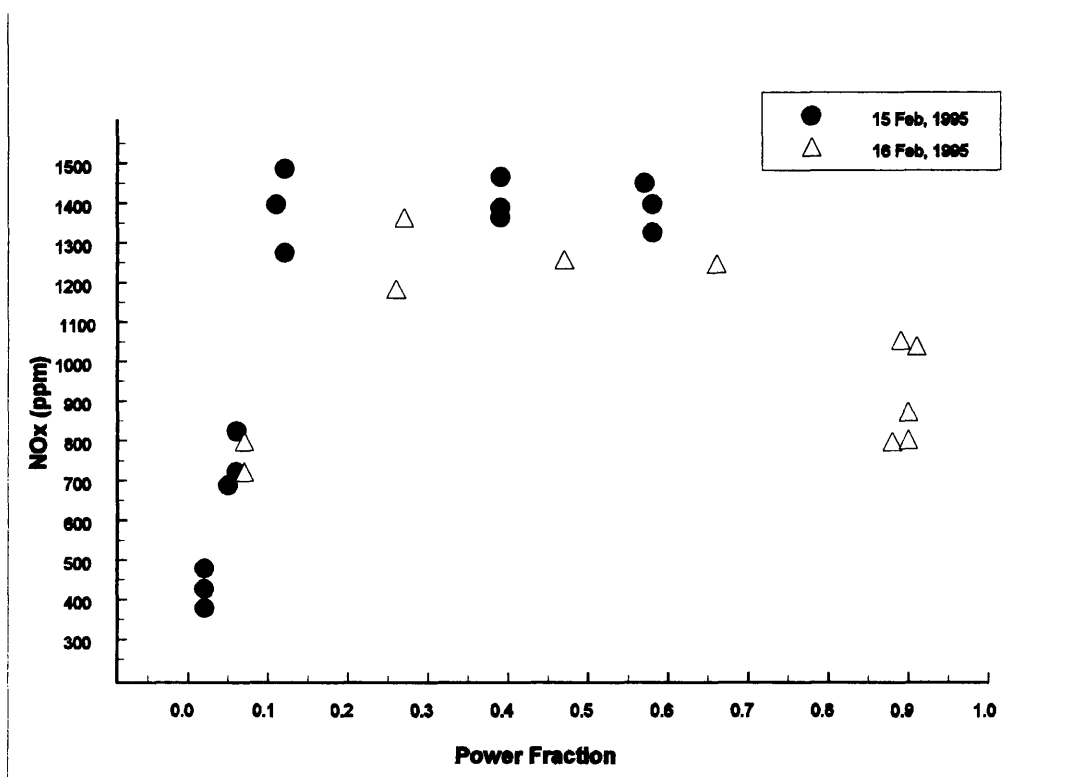
Variations in Emissions Measurements:

The emissions data was collected over two periods. The first was a six hour stretch in which the only one engine was powering the starboard shaft. The second combination included a combination of both plant alignments. Figures G-3 and G-4 plot the measured NOX concentrations in such a way as to differentiate data collected in dissimilar manners.

**Figure G-3: NO<sub>x</sub> (ppm) Differentiated by Plant Alignment**



**Figure G-4: NO<sub>x</sub> (ppm) Differentiated by Day of Testing**

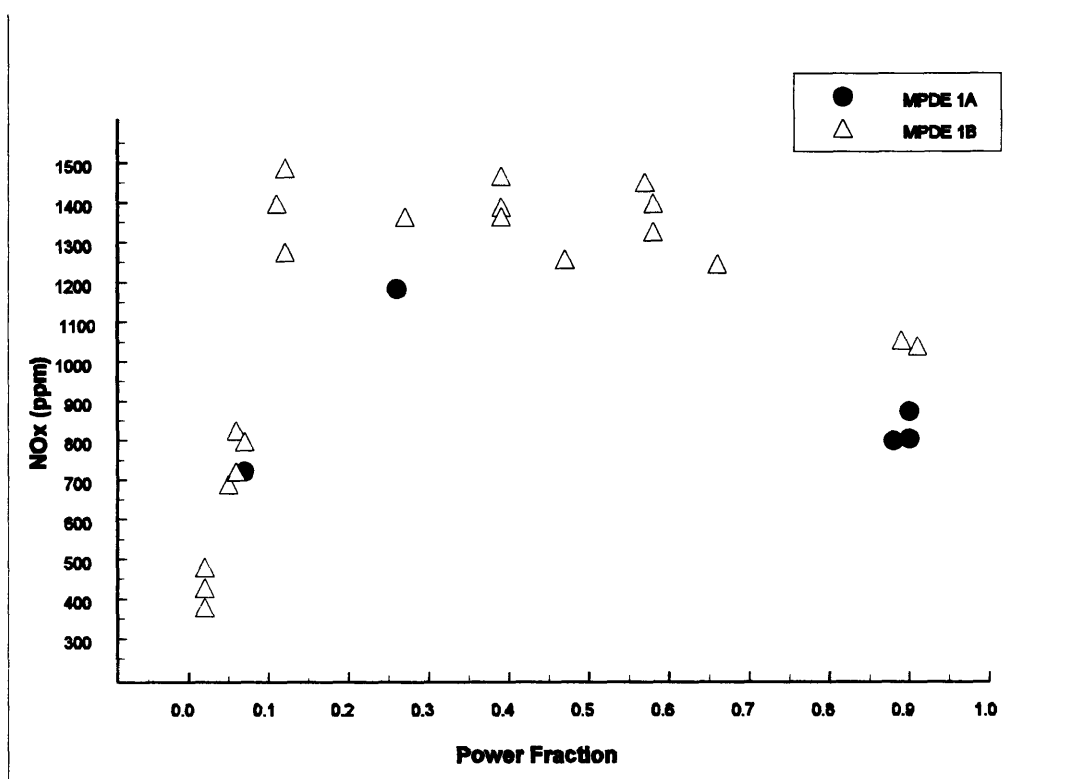


Two of the data points for data gathered on 16 February are for a single engine per shaft alignment. These points correspond to a power fraction of 0.45 (ship's speed of 15 knots) and 0.65 (ship's speed of 17 knots). The 15 February data points grouped immediately above and to the left of the aforementioned points also correspond to ship's speed of 15 and 17 knots, respectively. Significantly lower NO<sub>x</sub> concentration values were recorded on the second day of testing. Some of the deviation can be attributed to vastly different weather conditions (sea state one on 15 Feb and sea state three on 16 Feb), but drift in the calibration of the portable emission analyzers is considered the primary cause. As the rate of drift is unknown, the calibration data measured after shipment of the analyzer back to Groton, Connecticut should not be used in an attempt to equalize the data.

There was also a significant difference between the emission values measured by each model of portable analyzer. The ECOM KL, an older model, was used primarily on

MPDE 1B; the ECOM S+ was attached to MPDE 1A. The extent of these differences can be viewed in Figure G-5.

**G-5: NO<sub>x</sub> (ppm) Differentiated by Engine**



At one point during the ship's full power trial at 24 knots, the ECOM KL was transferred to MPDE 1A. The Nox measurement for this engine did not increase to the level that was being measured for MPDE 1B, indicating that the difference in the emission concentration levels could not be attributed to the portable analyzers.

The engine had both recently been adjusted by the engine manufacturer, but little operating time had been logged since. This is especially true for MPDE 1A which suffered two equipment casualties during the three day test period, placing the engine out of commission for most of the sea trial. As NO<sub>x</sub> emissions are sensitive to engine combustion conditions, one could expect small differences between the emissions concentrations for two engines of the same model. This still would not account for the variations seen in Figure G-5.

There is also a possibility that the probes were extended a different length into the exhaust pipe. Although a well mixed exhaust stream was anticipated earlier, which would have minimized concerns regarding exact probe placement in the exhaust pipe, this prediction was never verified at trials. The probe should have been slowly transversed across the diameter of the exhaust pipe in attempt to verify whether the temperature profile was constant throughout most of the middle diameter. If the flow could not be modeled as well mixed, the emissions concentrations may have been sensitive to the placement of the probe in the exhaust stream. This could account for the NO<sub>x</sub> level variations both over the two nights of testing and the two engines.