



VACUUM INSULATION

by

Harold William Anderson

B.S., 1921, E.E., 1929, University of Kansas
S.M., 1931, Massachusetts Institute of Technology

Submitted in Partial Fulfillment of the Requirement
for the Degree of
DOCTOR OF SCIENCE
from the
Massachusetts Institute of Technology
1934

Signature of Author _____

Department of Electrical Engineering, August, 1934

Professor in Charge of Research _____

Chairman of Departmental
Committee on Graduate Students _____

Head of Department _____

ACKNOWLEDGMENTS

During the work, the author has enjoyed the association of Dr. R. J. Van de Graaff and Dr. J. G. Trump, and he is in many ways indebted to them. In particular, he wishes to express his gratitude to Dr. Trump for cooperation in the rebuilding of the vacuum tank to include the high-voltage bushing and related equipment shown in Fig. 8. For inspiration and encouragement, the author extends thanks to Professor G. C. Dahl. For valuable suggestions, thanks are due to Professor R. D. Bennett. In the laboratory, the author was very fortunate to have as a neighbor, Dr. E. S. Lamar, whose interest and friendly suggestions have been of much value.

CONTENTS

	Page
CHAPTER I - INTRODUCTION	5
Statement of Problem	5
Need for Investigation	5
Previous Work	6
CHAPTER II - EXTERNAL APPARATUS USED FOR INVESTIGATION	9
Vacuum System	9
High-Voltage Lead-in Insulators	12
Generator	14
Voltmeter	16
Ammeter	19
CHAPTER III - APPARATUS IN VACUUM	21
First Experiments	21
Discussion of Electrode Apparatus	22
Electrode Apparatus Constructed	26
Error Due to Deflection of Parts	29
Elimination of Gaseous Conduction	30
Electrode Surface Gradients	32
Insulators in Vacuum	33
Vapor Sources	39
Compartment under Insulator	40
CHAPTER IV - GENERAL EXPERIMENTS	42
Observations Relating to Breakdown	42
Low-Voltage Equilibrium	44
Electrode Roughening	45
Preliminary Current Pulses	46
Effect of Electrode Conditioning on Breakdown Voltage	50
Space-Charge Effects	57
CHAPTER V - BREAKDOWN MEASUREMENTS	59
Procedure	59
Cathode Gradients	61

	Page
Measurements and Discussion	62
Breakdown Voltages Compared with Work Functions	125
Summary	126
CHAPTER VI - THE TOTAL-VOLTAGE EFFECT	128
Cathode Gradients	128
Possible Role of Positive Ions	131
Electrodes of Different Materials	132
Electrodes for Current Measurements	136
Current Measurements	140
Summary of Positive-Ion Indications	142
Amount of Conduction by Positive Ions	145
The Total-Voltage Effect	146
CHAPTER VII - CONCLUSION	147
Electrodes	147
Ceiling of Voltage	149
Safe Operating Gradients for Machinery	151
The Total-Voltage Effect	153
BIBLIOGRAPHY	154

VACUUM INSULATION

CHAPTER I

INTRODUCTION

STATEMENT OF PROBLEM

A gas between metal electrodes will act as an insulating medium if its cumulative ionization can be avoided. Since such ionization depends upon a sufficient acceleration of ions over a distance at least as great as the mean free path of the gas, it can be avoided if the mean free path is made large compared to the dimensions of the apparatus. Thus, for a given arrangement of electrodes and walls of a vacuum tank, there should exist a degree of vacuum beyond which the gas would exhibit insulating properties irrespective of applied voltage. With gas ionization removed as a factor, limiting conditions become properties of the electrodes themselves. A study of insulation under such vacuum conditions is the subject of the present investigation.

NEED FOR INVESTIGATION

Information about the factors affecting vacuum insulation is of basic importance in the design of high-voltage, vacuum-insulated devices. The need for the present work was in fact brought about by the planning of such devices

at the Massachusetts Institute of Technology by Dr. R. J. Van de Graaff, Dr. J. G. Trump, and their colleagues. Among the devices planned may be mentioned high-voltage discharge tubes, a vacuum belt generator, and vacuum electrostatic power machines, transmission lines, and accessory devices.

PREVIOUS WORK

It has been known for many years that conduction between electrodes in high vacuum can be produced by the application of sufficient voltage¹; and numerous observations of the phenomenon have been reported. From the outset, however, this conduction has been considered to be due entirely to electrons, and therefore related only to conditions on the surface of the cathode.²

Besides the above observations which relate to unheated cathodes, it has been noted that the emission of electrons from a hot filament could be increased beyond the saturation value for a given filament temperature by means of an increased potential gradient at the cathode. To explain this³,

1. R.W.Wood, A New Form of Cathode Discharge and the Production of X-Rays, together with Some Notes on Diffraction, Phys. Rev. 5, July, 1897, p.1.

R.A.Millikan and R.A.Sawyer, Extreme Ultra-Violet Spectra of Hot Sparks in High Vacuum, Phys. Rev. 12, 1918, p.167.

2. Millikan and Shackelford, On the Possibility of Pulling Electrons from Metals by Powerful Electric Fields, Phys. Rev. 15, 1920, p.239.

3. W.Schottky, ⁱⁱÜber den Austritt von Elektronen aus Glühdrähten bei verzögernden Potentialen, Ann. d. Phys. 44, 1914, s.1011.

Schottky proposed a theoretical relation,

$$i = i_T \mathcal{E}^{K \frac{\mathcal{E}^{\frac{1}{2}}}{T}}$$

In this equation, which represents what has since been designated the "Schottky effect",

i_T = saturation current at zero gradient and temperature T ,
 K = a constant,
 \mathcal{E} = potential gradient at the surface of the filament,
 T = absolute temperature.

In accordance with this relation, it should be possible at room temperature to secure emission from a cathode by the application of sufficient gradient, and current should have an exponential relation with the square root of gradient. To test the applicability of Schottky's formula to room-temperature observations, experimenters plotted the logarithm of measured current against the square root of voltage¹ (for the case of a fixed electrode separation). Results so plotted did not produce the straight lines required to satisfy the above formula, and experimenters began to seek empirical relations. Some found that the logarithm of current would give a linear plot against voltage.² Others found that the logarithm of current would give a linear plot against

1. R.A.Millikan and C.F.Eyring, Laws Governing the Pulling of Electrons Out of Metals by Intense Fields, Phys. Rev. 27, Jan., 1926, p.51.

Research Staff of the G. E. Co., London, The Emission of Electrons under the Influence of Intense Electric Fields, Phil. Mag. 1, Mar., 1926, p.609.

2. Previously unpublished work of W.D.Coolidge and I.Langmuir reported by Compton and Langmuir, Electrical Discharges in Gases, Part I, Rev. Mod. Phys., 2, Apr., 1930, p.163.

the reciprocal of cathode gradient.¹

The above reports seem to be unanimous in the premise that current is due entirely to cathode gradient, as the term "field current" implies. Sparking conditions are likewise found expressed in terms of cathode gradient. In one report, neither voltage nor information from which voltage can be derived is given. In other cases in which voltage is given, one article reports a voltage as high as 29 kv, and two others state that a 20-kv power supply was used. The remainder do not report voltages in excess of 8.5 kv. Thus, these investigations of interelectrode current, as well as accompanying measurements of sparking voltage, have been made with voltages small compared to those of the present investigation; and high cathode gradients have been obtained with pointed cathodes, very small spacing between electrodes, or both. Thus there is very little information as to what may be expected with voltages of the order of 100 kv or more, especially when cathode gradients are produced by an approximately uniform field. Cold emission is of course to be expected with high cathode gradients, but whether at high voltage it is the only important interelectrode phenomenon, present literature does not tell.

1. C.F.Eyring, S.S.Mackeown, and R.A.Millikan, Field Currents from Points, Phys. Rev. 31, May, 1928, p.900.
W.H.Bennett, Cold Emission from Unconditioned Surfaces, Phys. Rev. 37, Mar. 1931, p.582.
W.H.Bennett, Effect of the Target on Breakdown in Cold Emission, Phys. Rev. 40, May, 1932, p.416.

CHAPTER II

EXTERNAL APPARATUS USED FOR INVESTIGATION

Before dealing with the main experimental procedure of this investigation, descriptions of apparatus are given in this and the following chapter. As will be noted, the preparation of apparatus in many cases involved considerable experimental work.

VACUUM SYSTEM

The principal apparatus available for this work consisted of a large metal vacuum tank and an external electrostatic belt generator. Fig. 1 is a photograph of these devices and related equipment at a time near the completion of the work. The tank had been made from a seamless drawn brass cylinder having an inside diameter of 17.5 in., a length of 5 ft, and a wall thickness of 0.25 in. One end of the tank was permanently closed with a 1-in. rolled brass plate, soldered in position. To the other end was attached a flange of 1-in. rolled brass, extending outward for a radial distance of 2.75 in. This assembly had been mounted on wheels so that it might be rolled back and forth along a straight steel track 10 ft in length, mounted 3 ft above the floor. At one end of this track, perpendicular to the axis of the cylindrical tank, a 2-ft square plate of 1-in.

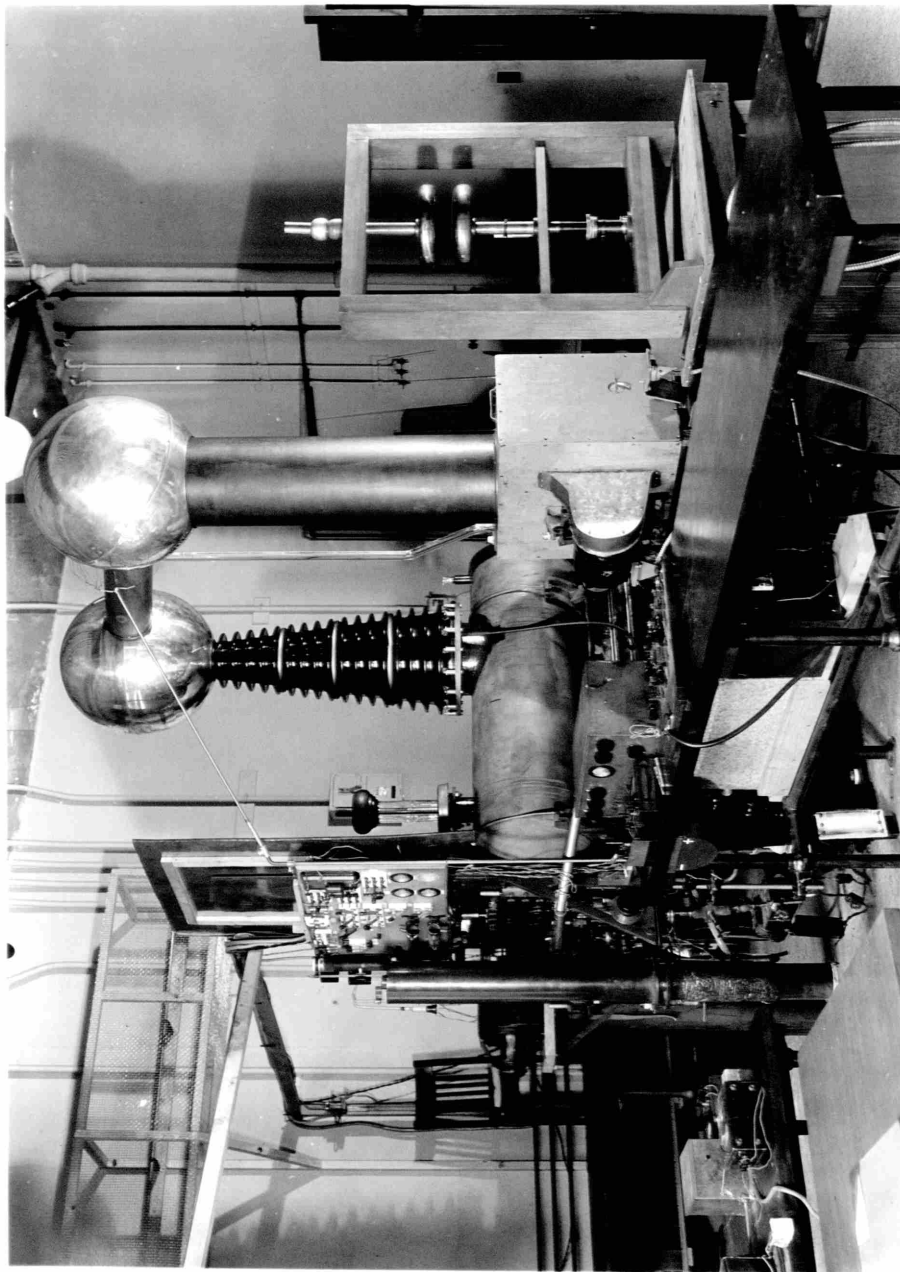

Fig. 1. General View of Apparatus

rolled brass was mounted to form an end plate against which the flanged end of the tank might be rolled and thus closed. For the vacuum seal between the end plate and flange, two concentric rubber gasket rings were used. During periods of operation of the tank, a forevacuum of 0.1 mm of mercury or less was maintained between these rings.

Pumping facilities of the above tank consisted of a 50-liter-per-second metal mercury diffusion pump, connected through a 5-in. valve in the stationary end plate. For backing this pump, a Cenco Hypervac was used until it was replaced by a glass pump containing a mercury diffusion and a jet stage. This was in turn backed by a Cenco Hyvac. For roughing out the vacuum tank, a Cenco Hypervac was used throughout the work.

Besides connections and valves for the pumps, the stationary end plate contained several other fittings. For transmission of motion into the vacuum, there were eight 5/16-in. steel shafts extending through the panel. These were sealed with a mixture of Apiezon grease and graphite, maintained by means of a plunger and weight arrangement under a pressure of about an atmosphere. For electrical connections, a variety of leads extended through the panel. These were sealed in glass which was in turn attached to the metal of the panel with Picein. They consisted of 7 10-mil leads, 2 75-mil, and 1 20-mil, the last having extra insulation for small-current measurements. For vacuum

measurements, there were connected through the panel a McLeod, an ionization, and a thermocouple gage. Besides these, a connection to the McLeod and an ionization gage were on the pump side of the large valve in the panel. Other thermocouple gages were connected between the diffusion pumps and at the outlet of the glass pump.

HIGH-VOLTAGE LEAD-IN INSULATORS

For bringing a high-voltage lead into the tank, a flange to which a section of 3-in. flanged Pyrex pipe could be clamped was installed. On this a 1-ft section of such pipe was first mounted, using a lead ring as a gasket between the glass and metal flanges. The upper end of the pipe was closed with a Picein-sealed metal disk, from which a 1-in. central metal tube extended into the tank to form the high-voltage connection. This arrangement performed satisfactorily up to the voltage of exterior breakdown which was only about 160 kv. In an attempt to increase this limiting voltage, a 2-ft section of Pyrex pipe was installed in place of the 1-ft piece. During the very first trial this was punctured at about 170 kv, indicating that a 2-ft length of this pipe is not self protecting by virtue of external flashover. After this experience, two 1-ft sections were placed together. As before, a 1-in. central core extended vertically through the assembly to form the high-voltage connection. From the junction of the glass cylinders, a concentrically arranged

2-in. thin metal cylinder extended downward to the interior of the top of the main vacuum tank. A thin flange at the top of this 2-in. metal cylinder rested on a ring of lead foil which extended through the vacuum seal to an exterior guard ring, thus connecting the cylinder and ring. This ring, which enclosed the necessary clamps for joining the Pyrex parts, would (at least in the case of a total voltage exceeding the external flashover value value of one pipe section) take an intermediate potential, which would also be the potential of the 2-in. cylindrical shield. Obviously this shield can not differ in potential from either the ground or the high-voltage part by more than the external breakdown voltage across either 1-ft pipe, which voltage was evidently insufficient to puncture the glass. (In no case did a 1-ft section fail.) Thus the compartment covered by either glass pipe was limited to a safe voltage for the glass. With this lead-in, however, the maximum attainable voltage was only slightly increased - the highest voltage ever recorded for it was 190 kv. This low limit was perhaps due to the proximity of other metal parts which could not have been readily moved. Nevertheless, neither glass section failed, and this was used until the installation of a much larger porcelain bushing.

The porcelain bushing had a height of 38 in. and a base diameter of 16.5 in. It was installed over a flange with a lead gasket as before. In this case three intermediate-

voltage shields were used, of which the external rings are evident in Fig. 1, page 10. The internal arrangement of concentric cylindrical shields and 2-in. central conductor may be seen in Fig. 8, page 40. As may be noted, a 2-ft sphere was placed at the top of this insulator. This assembly has been used successfully for voltages as high as 500 kv.

GENERATOR

One of the electrostatic belt generators constructed by Dr. E. H. Bramhall¹ was used as a source of d-c power throughout this work. This machine, of which the high-voltage portion was enclosed in a 2-ft sphere, was capable of attaining a potential of about 600 kv when running alone. Except for occasional periods of fluctuating output, it performed satisfactorily until late in the spring. At that time the former troubles recurred in a more serious way. Also it had an inherent tendency to run with its sphere positive regardless of excitation, and the opposite polarity was imperative for much of the work. To eliminate these difficulties, the cumulative belt-charging mechanism was removed from its base, and charging wires attached directly to the exciter were installed. Also numerous openings in its outer shell were closed and sealed with wax, and a shelf of drying agents was placed in its base. After these modifications

1. E.H.Bramhall, A Portable High-Voltage Generator of Practical Utility, R. S. I., 5, Jan., 1934, p.18.

it performed satisfactorily and with complete reliability through periods of very damp weather. Though the modification in charging wires had resulted in a reduction of current, it had also resulted in the machine's producing a remarkably steady current (and voltage).

The electrostatic generator operates by virtue of the belt-conveyance of charge between its base and high-voltage terminal. The charge placed on and removed from its belt is independent of the potential difference between its terminals. Therefore, except for the small leakage along its supporting column and belt, the machine is inherently a constant-current generator. Running alone, its sphere will rise in potential until the entire current delivered to it is lost, mostly through the agency of corona. In order to adjust the voltage to which the generator would rise, an adjustable corona leak was used. This consisted of a bundle of wires with separated ends, mounted on a long arm extending from a vertical shaft at one side of the vacuum-tank panel. Controlled from a lever near the voltmeter, the bundle of wires could be varied from a position in which the separated ends faced and made contact with the generator sphere, to a position in which the wire ends pointed away and were about 5 ft from the sphere. In the former position, this device is shown in Fig. 1, page 10. By adjusting the position of the lever, the voltage to which the generator would rise could be varied from the maximum value down to

about 15 kv. By connecting a smaller corona leak, using smaller wires moved by a screw mechanism, this range could be extended down to about 5 kv. For any one position of the corona leak, there would be but a small difference in voltage between the beginning of corona formation and the development of sufficient corona to take the generator's full current. Consequently the combination of generator and corona leak produced a unique voltage-current characteristic. Beginning at zero load current, the voltage would fall very slightly to the point corresponding to full current; beyond this the voltage would fall abruptly to zero. Thus, the characteristic resembles that of a shunt generator to a point where it suddenly changes to resemble that of a constant-current generator.

VOLTMETER

The first piece of apparatus constructed was a gap for voltage measurement. This was constructed in accordance with a design¹ intended to produce a nearly uniform field for gaps below a certain limiting value. Within this range it therefore had an essentially linear calibration; and it also had the advantage of greater compactness than a sphere gap of equivalent range. This gap may be seen in Fig. 1 of page 10 at the right of the generator. For calibration it

1. J.D. Stephenson, Corona and Spark Discharges in Gases, Jr. I. E. E. 73, July, 1933, p.69.

was taken to the research laboratory of the Simplex Wire and Cable Company.

Though the above gap was quite suitable as a secondary voltage standard, it could by no means serve as an indicating voltmeter. Consequently such an instrument had to be devised. For this there seemed to be two practical schemes from which to choose: a generating type, and a high-resistance type. To secure reasonable accuracy, the former would have to be constructed with considerable precision, and be rigidly (but adjustably) mounted with shielded connections. Also it should be used in a region in which the electrostatic field retained its shape, merely varying in magnitude in accordance with voltage. This would require that it be used with apparatus developing little or no corona, and having no insulating surfaces exposed to strong fields. These considerations, coupled with the fact that the construction of a generating voltmeter would have required considerable time, were the basis of choosing the high-resistance type of meter.

The high-resistance voltmeter differed from the generating type in one undesirable way - its operation required a definite part of the generator's output. Since under certain conditions of operation, the total current of the generator amounted to only about 80 μ amp, the voltmeter resistance had to be extremely high. Moreover it had to be physically such that it would not flash over or be the source of corona loss at the highest voltage. Such a resistance

was obtained with a mixture of technical meta xylene and chemically pure ethyl alcohol, the latter having a 5 percent water content. As finally arranged, this mixture was placed in a 34-mm Pyrex tube 135 cm long. An electrode consisting of a 3-cm nickel disk was used at each end of this tube; the lower electrode was attached to a tungsten seal, and the upper electrode was mounted on a nickel wire which extended through a rubber stopper. In Fig. 1 on page 10, this resistance can be seen extending from the bottom of the 7-in. cylinder between the 2-ft spheres to a bracket attached to the base of the generator. From the lower electrode, a connection was made through a lead-covered cable to a microammeter on the table at the left.

The mixture for the above voltmeter resistance was, after several preliminary experiments, made with 100 parts of xylene and 11 parts of alcohol. This at first resulted in a resistance of 8×10^9 ohms but in the course of a month dropped to about half of this value. A new mixture was then prepared. To 100 parts of xylene, 4 parts of alcohol were added. The resulting mixture had the milky appearance of an emulsion, and was allowed to stand in a closed bottle over night. Next day, drops (apparently of water from the alcohol) had settled on the bottom of the bottle leaving a very clear fluid above. Without disturbing the drops the fluid above was siphoned away for use. It, however, had too high a resistance for the microammeter chosen for this

purpose. The alcohol content was therefore increased (without again producing a milky appearance). By the time the alcohol content had been increased to 7 parts, the resistance had what was considered a suitable value, 1.6×10^{10} ohms. This value remained essentially unchanged through 2 months of intensive service. It was found to be independent of applied voltage at least to 150 kv. From day to day, however, its resistance fluctuated as much as 5 percent; which variations were at first attributed to temperature changes, but no consistent correlation was observed. Power dissipation in it was too small (2.5 watts at 200 kv) to produce appreciable heating. Throughout the work the practice was maintained of making very frequent checks on the voltmeter calibration. For this purpose, a connection of brass tubing was laid between a socket at the top of the spark gap and the generator sphere.

AMMETER

The instrument used for the measurement of leakage current between electrodes in vacuum was a type R (2500 f) Leeds and Northrup galvanometer, equipped with an Ayrton shunt. This apparatus and its connections were of course shielded. Since during much of the work sparking between electrodes was imminent, this instrument had to be protected against the surge which would accompany such an occurrence. This was accomplished by placing in series with the galva-

nometer circuit a suitable resistance ahead of which a protective spark gap was connected to ground. This gap was made with 0.5-in. steel spheres closely spaced to spark in the atmosphere at about 600 volts. Consequently the resistance in series with the galvanometer had to be such that this voltage drop would be produced at some chosen current slightly greater than the largest value to be measured. As actually carried out, three different resistances were used in this manner for different current ranges. The resistances were made with xylene-alcohol mixtures in glass tubes.

CHAPTER III

APPARATUS IN VACUUM

FIRST EXPERIMENTS

The first experimental work of the present investigation of vacuum insulation was the measurement of breakdown voltages between electrodes consisting of 0.5-in. steel balls. These balls, which were of the type intended for bearings, were each spot welded with an intermediate nickel member to a tungsten rod. By sealing the tungsten rods into Pyrex frames, sphere gaps were made for measurements in the vacuum tank. A gap so constructed, of course, provided but a single fixed electrode separation. In order to secure a variation of this parameter, several such gaps were prepared for simultaneous mounting in the vacuum tank and were connected by means of a multiple-point switch to the high-voltage terminal.

With the above procedure, numerous difficulties were encountered. Troubles with the drawn Pyrex parts are discussed under the heading of "Insulators in Vacuum" on page 33. The high-voltage switch proved to be an undesirable complication. The lack of control of electrode separation from the outside of the vacuum tank was very soon found to be a serious handicap. After being sparked a few times, these gaps would sometimes change to a condition which

would not permit further breakdown. Instead of rising to breakdown voltage, the generator and gap would come to equilibrium at a fraction of this voltage. Evidently the gap was permitting the flow of a relatively large leakage current. The equilibrium voltage was of course that voltage at which the current taken by the gap equaled the net current which the generator could supply. Whenever this condition developed, further measurements of breakdown voltage for that gap length could not be obtained; and in this manner some points on the range of interelectrode distance were lost. Other gaps, however, would continue to exhibit good insulating qualities, and their breakdown voltages would for a time rise with repeated sparking. As a consequence of this experience, it became apparent that, to determine characteristics as a function of distance between electrodes, measurements should not be made on a succession of different electrodes with different spacings but on the same pair of electrodes with spacing varied.

DISCUSSION OF ELECTRODE APPARATUS

On the basis of the above experience, the requirements which an electrode arrangement should meet may be outlined as follows:

- (1) On each electrode, there should be available several different points at which tests might be made; and it should be possible to align for test any combination of these points.

- (2) The distance between electrodes should be adjustable. When the electrodes are moved together and then separated for a test it should be possible to accurately determine their point of separation and measure distances therefrom.
- (3) It should be possible to sufficiently isolate the electrodes to subject either to an electron bombardment.
- (4) The electrode on the ground side should be insulated and connected with a shielded lead for current measurement. This arrangement would also be necessary for the application of voltage for electron bombardment.

Though spherical electrodes were used in the first experiments, an arrangement consisting of a sphere and plane would possess the following advantages:

- (1) In order to accurately measure the distance introduced by the movement of one sphere away from another, they would have to be mounted so that their motion of separation would take place along the line joining their centers. In the case of a sphere and plane, however, it would only be necessary to have the plane perpendicular to the line of motion.
- (2) A thin plate could be heated and would cool more readily than a sphere - the latter is in fact the least desirable of all shapes from the viewpoint of cooling by radiation.
- (3) An arrangement to experiment with pieces of flat stock would be of definite practical advantage, and tests would more closely simulate what would seem to be practical for the electrodes of a machine.

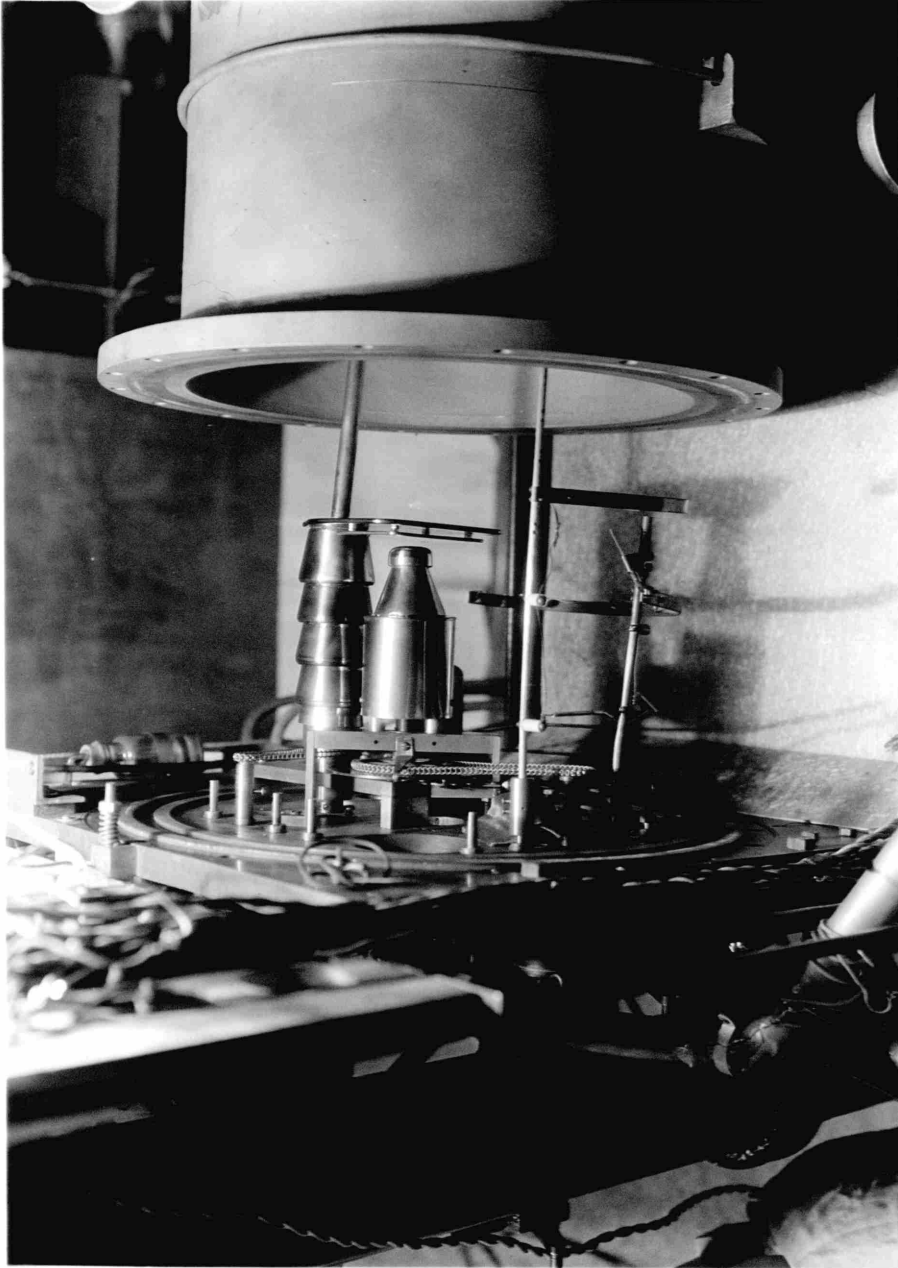

Fig. 2. Apparatus on Inside of Vacuum-Tank Panel

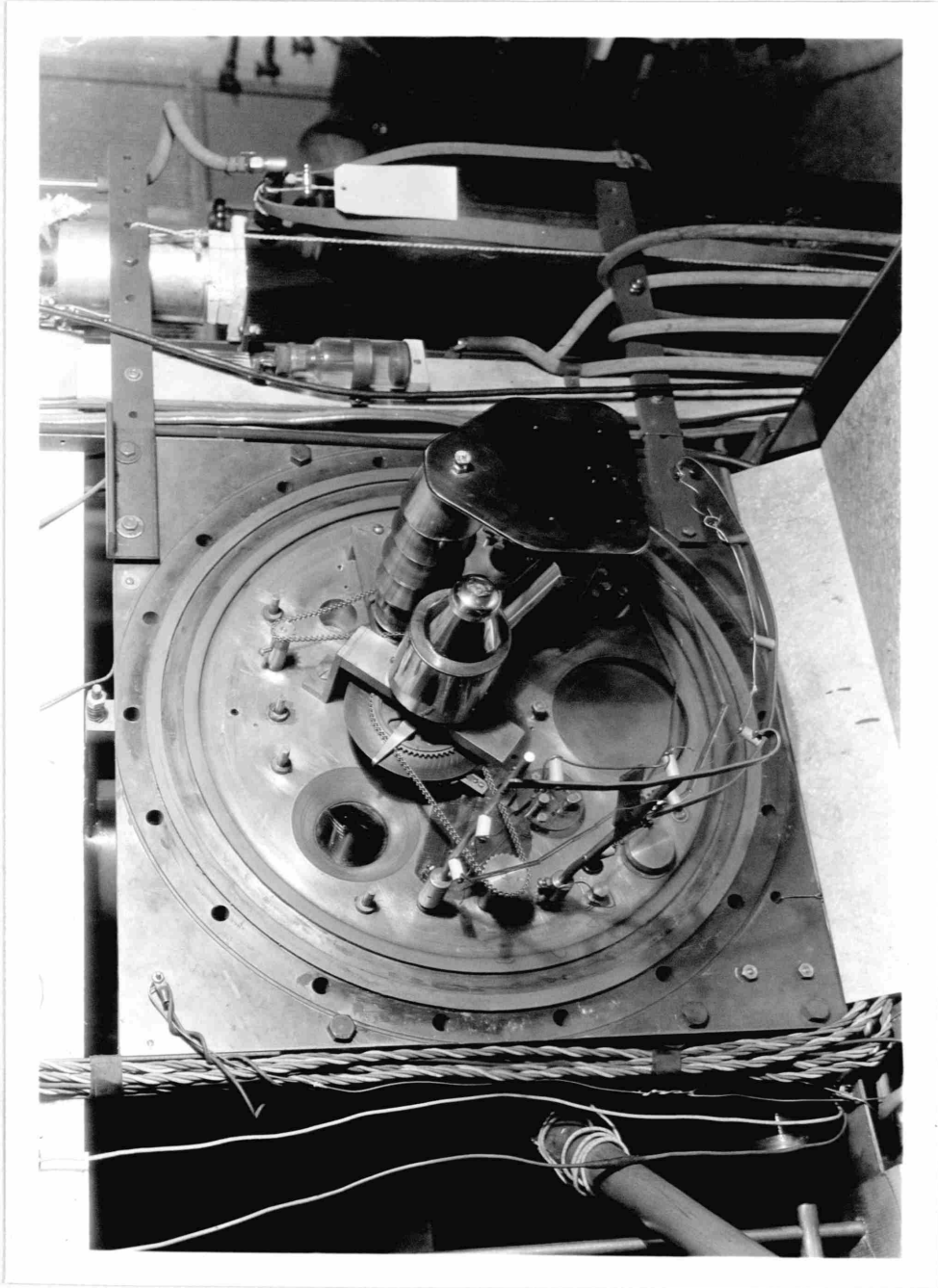

Fig. 3. Apparatus on Inside of Vacuum-Tank Panel

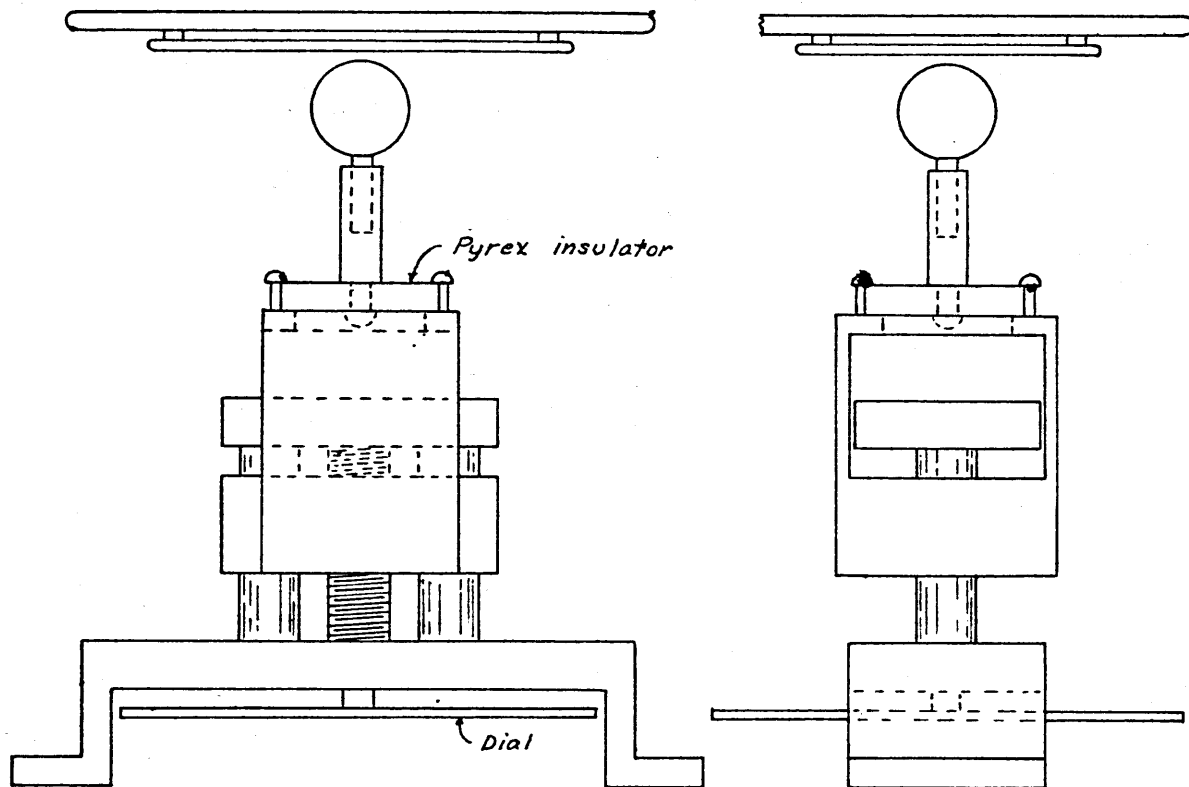

Fig. 4. Electrode mechanism with shielding removed

ELECTRODE APPARATUS CONSTRUCTED

The apparatus built for this work may be seen mounted on the panel of the vacuum tank in the photographs of Figs. 2 and 3. In these figures the spherical electrode has been replaced by a guard-ring anode which is to be mentioned later. The arrangement of the principal parts of this mechanism, some of which are concealed by shielding in Figs. 2 and 3, is indicated in Fig. 4. For the spherical electrodes, a diameter 1 in. was chosen for this work. After the attachment of 3/16-in. stems, these could be mounted for test in

a chuck as is indicated in Fig. 4. The chuck was supported, through an insulating slab of Pyrex, by the movable part of a screw mechanism by which means the sphere could be accurately moved in a direction perpendicular to the plane of the opposite flat electrode. The screw controlling this motion was fitted with ball bearings to reduce end play, and carried a dial for the measurement of distance. The part moved by this screw traveled upon accurately machined guides which were part of a rigid assembly built out from the panel of the tank. By means of a chain and sprockets, the screw shaft was connected to a shaft extending through the tank panel.

The plate to which the flat electrode is attached was clamped to the end of a shielded stand-off insulator, 2 in. in diameter and 7.25 in. long. Extending to the right from this plate is a tubular high-voltage lead, which has been removed in Fig. 3. At its left end, the stand-off insulator was fitted with a bearing so that it might be rotated about its axis, and was connected with a chain to a shaft extending through the panel. By means of the rotation of this insulator, the plane electrode could be moved to secure different test points lying along a circular arc. By this same movement the plane electrode could be turned downward as shown in Fig. 3. In this position it could be bombarded by electrons from a filament which could be moved in front of it by means of another of the controls extending through

the panel. Also this position of the plate exposed the sphere for bombardment from another filament which could be moved into a suitable position for that purpose.

It may be noted that the above apparatus provides for obtaining different test points on the flat electrode, but only a single point is available upon the sphere. The apparatus as built first did provide for obtaining different points on the sphere by means of its rotation about an oblique axis. This arrangement, however, introduced undesirable flexibility into the electrode support. Also, as later discussion will indicate, it was found unnecessary to obtain different points on this electrode. Consequently, the above described sphere mounting was chosen.

For determination of the point of separation as electrodes were moved apart, a lever system with a tilting mirror was first tried. Certain parts of this projected and exposed insufficiently rounded edges which were evidently sources of cold emission when the high-voltage parts were negative, as was manifest by blue spots on the tank wall. Since such trouble seemed difficult to avoid, this scheme of determining electrode contact was abandoned. In its place, an electrical test was used. For this purpose, the electrodes were connected through a 20,000-ohm resistor and a microammeter to a single dry cell.

ERROR DUE TO DEFLECTION OF PARTS

A possible source of error with the above electrode supports consists in the bending of the parts caused by electrostatic attraction between electrodes. The force between the sphere and the plane for a certain separation and potential difference would be the same as that between two spheres with twice the separation and twice the potential difference. Referring to a table given by Lord Kelvin¹, the second line from the top corresponds for a 2.54-cm sphere to a sphere-to-sphere spacing of 1.27 mm, or a sphere-to-plane spacing of 0.637 mm. Assuming an average gradient along the shortest distance of 10^6 volts per cm, the potential difference between spheres amounts to 1.27×10^5 volts, or 423 statvolts. With one sphere grounded and the other differing by this voltage, the force between them will be 2.04×10^6 dynes or 0.46 lb. From the results of measurements of the change in the point of contact with larger forces, this force would cause a deflection of the plate of about 0.002 mm. This corresponds to an error of about 1/3 percent. For a fixed spacing, the force varies as the square of gradient. If force remains unchanged, the error of course varies inversely with spacing. With the above force, the spherical electrode was not found to move appreciably. It may be noted that the above error is in such a

1. Reprint of Papers on Electrostatics and Magnetism, Macmillan, 1884, p.96, Table I, c = 2.1.

direction as to cause a conservative result, i.e., break-down voltage would be reduced ^{by the} _{springing together of the} electrodes.

ELIMINATION OF GASEOUS CONDUCTION

An important question in the present investigation concerns the margin of pressure by which the work is removed from gaseous conduction. To answer this question experimentally, the following observations were made during the process of pumping out the tank at a time when it contained the electrode apparatus arranged for a test. When the pressure had reached a few millimeters, at which value it was known a gas discharge could readily take place, the generator was started with its corona leak in a

remote position. At the first sign of a rise in voltage, simultaneous readings of pressure and voltage plotted in Fig. 5 were begun, and were continued as long as voltage

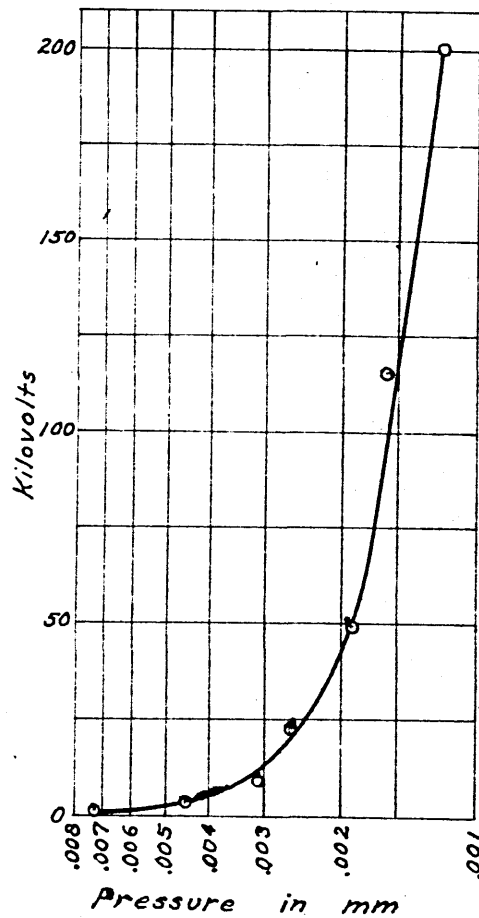

Fig. 5. Voltage vs pressure

increased. This curve represents voltage, as a function of pressure, for the current the generator could supply. Thus the gas discharge which occurred at low voltage carried a current of about 100 μ amp, but as voltage rose an increasing part of this current was diverted from the tank by the voltmeter and external leakage. When readings were started, i.e., when voltage was beginning to rise, the discharge in the tank was necessarily taking place in regions of long paths. Consequently the restricted movement which could be given the relatively closely spaced electrodes near the tank panel should not have influenced the discharge, and this was observed to be the case.

In preparation for the measurements of this investigation, the vacuum tank was regularly pumped down to a pressure in the range of 10^{-5} to 10^{-6} mm. Upon the first application of high voltage (with the generator's corona control in a remote position), pressure would usually rise to nearly 10^{-4} mm, but would in a few minutes fall to about 3×10^{-5} mm. Upon the removal of high voltage, the pressure would fall to a value slightly below that which had existed before the application of voltage. Unless the apparatus was allowed to stand for hours without voltage, its subsequent applications would seldom cause the pressure to rise as high as 3×10^{-5} mm. As this is less than 3 percent of the lowest pressure of the curve of Fig. 5, it can be seen that the work of this investigation was done at pressures well below

those at which gaseous conduction occurs. As a further experimental check, comparisons of measurements of breakdown voltage have shown no dependence upon pressure with values below about 10^{-4} mm.

The above conclusion may be substantiated from the viewpoint of the average distance between ionizing collisions of an electron. Data from Rutherford¹ indicate that a β particle will cause in the atmosphere up to 136 ionizing collisionizing per centimeter of travel, corresponding to a distance of about 7×10^{-3} cm between collisions. With a pressure of 10^{-3} mm, the average travel between ionizing collisions would become about 50 m. Since this is long compared to the dimensions of the apparatus, cumulative ionization could not occur at this pressure.

ELECTRODE SURFACE GRADIENTS

Between a spherical and a plane electrode, maximum electric field strength will exist along the perpendicular from the plane to the point of the sphere nearest the plane, which is the shortest distance between such electrodes. The average gradient along this line will of course equal the quotient of potential difference and distance. On smooth electrode surfaces at either end of this perpendicular, the gradients may be expressed in terms of this average value

1. E. Rutherford, Radioactive Substances and their Radiations, Cambridge University Press, 1913, p.250.

by factors which are functions of distance, and which approach the limit of unity as distance approaches zero. The ratio of gradient on the spherical surface to the average value may be computed with a formula given by Peek.¹ Using distances to an image sphere equal to twice those to the plane, values of this ratio for a 1-in. sphere were computed and plotted in Fig. 6. In this same figure are also plotted values of the corresponding ratio for the plane electrode, which were computed from another formula by Peek.²

INSULATORS IN VACUUM

During this investigation, many arrangements of apparatus were tried which involved supporting high-voltage parts in the vacuum tank. In the very first experiments, Pyrex rods were used to support parts of a multiple-point switch and for the frame work of test sphere gaps. When high voltage was applied to this assembly, sparking and glowing set in along the glass, and some parts actually fell into pieces. V-shaped grooves were frequently chipped out along the length of a rod. This sort of performance of the Pyrex was obviously due to the existence of slim elongated bubbles in the drawn rods. If the gas in these bubbles

1. F.W.Peek, Jr., Dielectric Phenomena in High-Voltage Engineering, ed.3, McGraw-Hill, 1929, p.69, formula for f.

2. Loc. cit., p.69, (26), quantity in brackets with a = X/2.

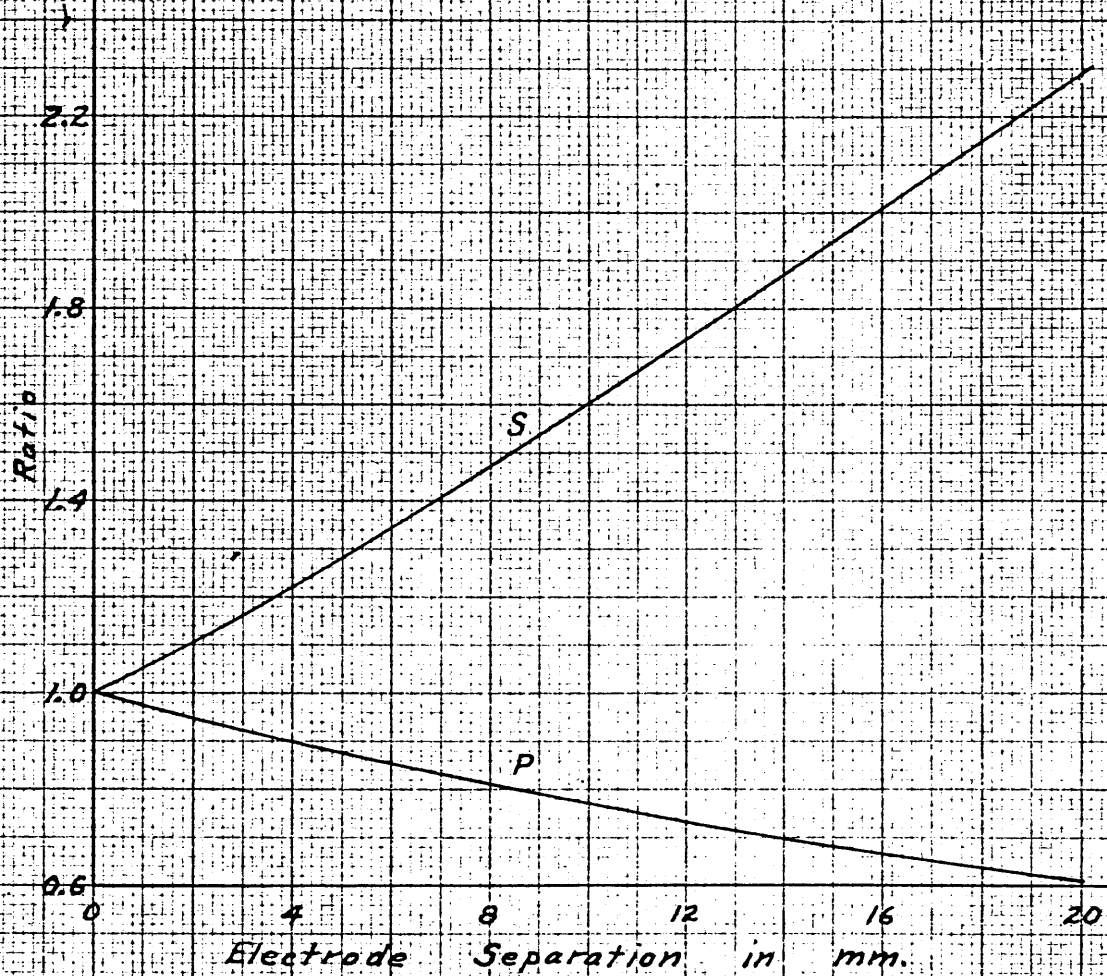

Fig. 6. Ratio of maximum surface gradient to average gradient on shortest connecting line, for electrodes consisting of a 1-in. sphere and plane, as a function of distance between electrodes

S, for spherical surface

P, for plane surface

had been at about atmospheric pressure during the drawing process, it would at room temperature have a pressure of about $1/7$ atmosphere. Thus the bubbles could not be expected to support a large difference in potential; and they might be likened to conducting fibers strewn longitudinally throughout a rod. This would result in large local stresses in the Pyrex, especially in regions from which bubbles extended in opposite directions. Puncturing between two such bubbles would result in a lengthened bubble and likely worse stresses at its ends. Thus the disintegration of the drawn Pyrex parts is not surprising. Incidentally, cast Pyrex with its separated spherical bubbles would seem to be free of this trouble; and this proved to be the case with a piece which was tested. The use of Pyrex castings, however, would bring up numerous problems in connection with the attaching of metal parts to them. The ordinary cementing methods would of course be open to serious question for vacuum practice because of the manner in which such materials would emit gas.

For the support of the high-voltage plate of the electrode apparatus, an Isolantite stand-off insulator was used. This porcelain-like substance, of which the manufacturers do not announce the composition, possessed certain basic advantages over glass. It had surprising strength, and it could be obtained with holes threaded for machine screws. (Such operations as the threading of holes were done while

the material was in a chalky condition, previous to firing.) A smooth cylinder of this material, 2 in. in diameter and $7 \frac{1}{8}$ in. long with ground surfaces and threaded holes at each end, was used in the present case.

When voltages much beyond 100 kv were applied across this insulator, its surface seemed to be the seat of irregular shifting streamers which seemed to increase with time. After the

heating of nearby metal parts this insulator would be coated with a (usually gray) film, and the above effects would set in at about 50 kv, often preventing an increase of voltage much beyond this value.

The most obvious means of contending with this difficulty was to provide shielding. Shields, as sketched in Fig. 7 and also shown in the photographs of Figs. 2 and 3 on pages 24 and 25, were spun from 18-mil sheet nickel. As may be noted, these presented the narrow sheet-metal edges toward each other, and a rounded surface toward external objects. Consequently it was expected that the

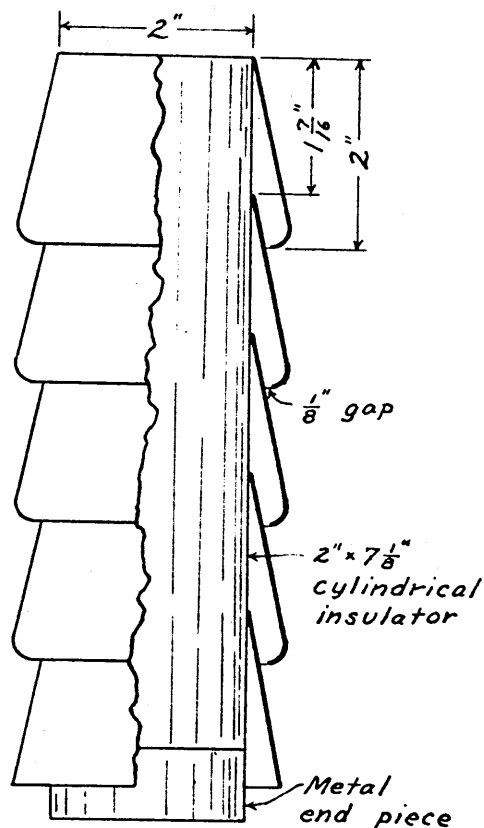

Fig. 7. Shielded Insulator

potential difference between shields would be limited (by cold emission from the edges), but any shield would not be so limited with respect to properly rounded external objects. When this assembly of insulator and shields was first tried, negative voltages in excess of 150 kv caused bright spots to appear on the surfaces of the shields opposite nearby edges, indicating the presence of electron beams. To eliminate this the shields were removed and polished on their lower edges with fine emery paper. The upper edges were left quite sharp because of the greater spacing to the next shield. After cleaning and reassembling, this insulator remained completely dark and gave no evidence of trouble with voltages up to about 200 kv, the highest voltage which was placed upon it. It served without further attention throughout the investigation.

In contrast to the above, another experience with an insulator will be described. A certain experiment required a second high-voltage in the tank. At the time of this work, a deeply corrugated type of Isolantite stand-off insulator was available in units 2 in. long. Four such units were placed together with intermediate steel disks, making an assembly about 8.5 in. long. The application of about 150 kv across this caused it to glow brightly. Presently the voltage began to be pulled down, and a red glow was noticed in parts of the spaces between fins of the insulator. As the voltage continued to fall, the work was

necessarily stopped. When the insulator was removed, it was found to have been punctured at the bases of its fins along its entire length.

The failures of the insulator fins must certainly have occurred successively, which conclusion would be checked by the gradual fall of voltage during a period of several minutes. This might be explained as the spreading of a crack originally present, but for the fact that the insulator was in 4 parts with steel separators between them. What seems to be a possible explanation follows. Cold emission from the edges of the fins near the negative (high-voltage) end probably prevented their taking a potential in proportion to their position along the insulator's length. This resulted in the stressing and puncturing of the material at the base of the top fin. The crack thus formed, having a low pumping speed, became conducting due to ionization of gas from the freshly exposed material. This caused an increased stress upon the next fin, and a repetition of the cycle until the insulator had been completely broken down.

It is believed that the experiments just described indicate the soundness of the principle of shielding insulators in a manner to control the subdivision of voltage along their length. The second case exemplifies the manner in which stresses may be concentrated in vacuum. In air, the above corrugated insulators were found to be self protecting by virtue of external flashover. In vacuum such

insulators should be so sectionalized with shielding that the voltage across any one section is definitely limited to a value less than the puncturing voltage at the base of one fin.

VAPOR SOURCES

The vacuum tank of this investigation contained two obvious sources of vapor. Rubber gaskets were used between the tank flange and the panel, and on the two valves in the panel. At each of these places, especially on the valve which stood open during operation, rubber was directly exposed to the vacuum. Grease seals were used on the various shafts for transmitting motion into the tank, thus exposing grease to the vacuum. Though the tank was equipped with a liquid-air trap having an average cold area of 150 sq cm, it became increasingly alluring during the work to make measurements in a region partitioned against the above vapor sources. With the electrode apparatus which was mounted upon the panel, there seemed to be no practical way of accomplishing this. It was finally decided, therefore, to move the test electrodes to a new position directly under the large porcelain lead-in bushing, where a compartment to provide a vapor-free region was built. The high-voltage electrode was directly attached to the bottom of the 2-in. steel core which extended down from the top of the insulator to form the high-voltage lead. Thus the high-voltage parts

were reduced to this single piece. The need for a supporting insulator in the vacuum was thereby eliminated, as may be seen in Fig. 8.

COMPARTMENT UNDER INSULATOR

The compartment to provide a vapor-free test region is shown in Fig. 8. It was formed by placing a pan-shaped partition under the large lead-in bushing. This was constructed of steel and sheet nickel with mechanically tight joints, formed either by the usual folding process for sheet metal or by clamping parts between heavy steel

pieces. At its top, the pan

was sealed with a lead-ring gasket to the upper surface of the tank flange, which also carried the bushing. For supporting and controlling the position of the movable electrode, a vertical shaft fitted with a long sleeve bearing extended into this compartment from the interior of the tank. Measured movement of this shaft was obtained by

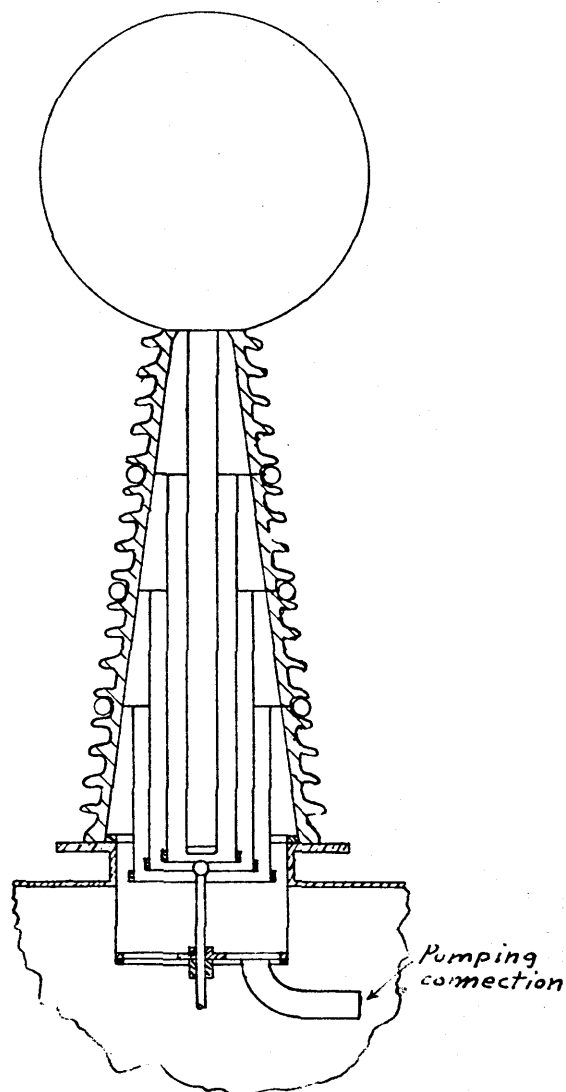

Fig. 8. Test compartment under lead-in insulator

means of a screw mechanism directly below the compartment. The control shaft of this mechanism continued downward, passing through the wall of the vacuum tank with a grease seal, and terminating in a dial and crank. The separation of the electrodes in this case could be varied from zero to several centimeters.

As already stated, the above enclosure was designed to prevent rapid diffusion from the tank to the inside of the compartment except by way of the liquid-air trap, which would condense vapors. The relatively small amount of condensable vapor which would diffuse past the joints and shaft of the compartment would be condensed by the part of the liquid-air trap facing into the pumping connection. Also, as an additional feature, it may be noted that the partitioning eliminated the brass wall of the main tank as a part of the interior of the high-voltage compartment.

CHAPTER IV

GENERAL EXPERIMENTS

Aside from various auxiliary work to which some reference has already been made, the main experimental procedure is divided among the following groups:

- (1) General experiments (this chapter),
- (2) Measurements of breakdown voltage,
- (3) Investigation of the total-voltage effect.

Under these chapter headings the experimental work and its interpretation are discussed.

OBSERVATIONS RELATING TO BREAKDOWN

The first experiments were made with a group of small sphere gaps of fixed spacing, mounted in the vacuum tank. Their electrodes consisted of 0.5-in. steel balls intended for bearings. The principal observations from this work follow:

- (1) When the voltage across one of the gaps was brought to a sufficiently high value, a clear spark would occur between the electrodes. Such sparking is to be designated by the usual term, "breakdown". When breakdown occurred, the accompanying surge due to the stored electrostatic energy generally produced inductive effects about the laboratory - extraneous sparking various metal objects with the charac-

teristic noise of sparks, and occasional power-circuit trouble. These inductive effects accompanying breakdown in vacuum usually seemed much more violent than those which accompanied sparking (at the same voltage) between electrodes of the voltage-measuring gap in the atmosphere. Evidently the gap in vacuum (which was of course much the shorter) allowed a considerably larger instantaneous current to flow.

(2) The voltage required for sparking between electrodes usually rises with successive breakdown when the electrodes are new or when they have been without voltage for a few hours. The final voltage obtained in this manner will sometimes amount to as much as 2 or 3 times that of the first spark.

(3) A gap may at the time of application of voltage or during sparking change to a condition that will allow the full current from the generator to pass between electrodes at a voltage which is only a fraction of that corresponding to breakdown. In this condition, the gap and generator will come to equilibrium without the occurrence of sparking.

(4) The gaps were found to be very changeable in their characteristics, likely due to the possibility of wide variation in surface conditions.

(5) After removal from the tank, the electrodes were found to have been considerably roughened. (This is to be described in more detail later.)

LOW-VOLTAGE EQUILIBRIUM

With the apparatus arranged to support a flat electrode opposite a sphere so that fresh surfaces could be obtained on either, further observations were made of the phenomenon of the generator and gap coming to equilibrium at a voltage too small for sparking:

(1) When the condition of low-voltage equilibrium had occurred, changing to a new region on the anode but retaining the old cathode region was never found to alter the condition.

(2) The opposite sort of electrode change - changing the cathode but retaining the anode surface seemed to have as good a chance of altering the condition and causing a rise to sparking voltage as a fresh gap had of rising to sparking voltage. In the case of a spherical anode and flat cathode, it was striking how little the cathode would have to be moved along its plane for a complete change of behavior in regard to sparking. A shift of 1 mm would often be as effective as several centimeters.

(3) With low-voltage equilibrium, a fairly stable condition would usually obtain. During a half hour of continuous operation, voltage has been observed to change less than 10 percent from the average value.

(4) When sparking voltage could not be reached on account of the above condition, a reversal of polarity would often result in the necessary rise in voltage. If it did, the gap would quite likely also spark when returned to the original

polarity. In any case, if the resumption of sparking could be brought about, the gap would usually build up to a condition of high breakdown voltage.

On the basis of the above experiments, low-voltage equilibrium is evidently due entirely to a condition of the cathode - which of course suggests cold emission of electrons from a point. The susceptibility of the phenomenon to small shifts of the cathode, showing a high sensitivity to gradient, are indicative of this. Once formed, a point would likely continue as a copious emitter until destroyed by sparking.

ELECTRODE ROUGHENING

As a consequence of breakdown, some marking would be found upon both anode and cathode. The resulting rough areas, when viewed with a binocular microscope, presented appearances characteristic of polarity. The anode markings had a comparatively smooth and less jagged appearance than those of the cathode. The former might be described as a region of rounded hills gradually reducing in height toward the edge of the area. Beyond the region of perceptible marking, a border of intense metallic luster would often be seen. With nickel this border has been seen in widths up to about 3 mm, but with steel it was seldom wider than about 0.5 mm. Though the roughened areas thus appeared to be surrounded by a band of exceedingly clean metal, it seems likely

that the central area was equally clean but unable to appear so lustrous on account of its roughness. The cathode markings appeared as craters of varying size and shape but surrounded by jagged edges. The rough border surrounding a crater or cluster of craters would terminate abruptly in unroughened portions of the cathode surface.

Large readily visible scratches on either electrode often seemed to have little effect upon the voltage at which sparking would occur. In cases where scratches had extended through the areas roughened by sparking, the scratches were often seen to have been nearly obliterated. This would obviously explain their small effect after the occurrence of some sparking.

As later observations will indicate, sparking causes a greater increase in breakdown voltage than has been secured in any other way. This increase is accompanied by rather severe roughening of the electrodes, which would seem extremely likely to cause intensified surface gradients. Since breakdown voltage rises in spite of roughening, the actual surface improvement must be in greater proportion than is indicated by the ratio of breakdown voltages.

PRELIMINARY CURRENT PULSES

Early in the investigation, measurements were made of leakage current between the electrodes then in use - a sphere opposite a plane. When voltage is applied to the electrodes,

the galvanometer will almost invariably make a few sudden but not violent swings at voltages small compared to that which will eventually produce even the smallest current that could be detected by the galvanometer. Having once passed through this region of current pulses, the removal and prompt reapplication of voltage will not again produce them. If, however, voltage is not applied for about an hour or more, these preliminary pulses will again accompany its application in much the same manner as they originally occurred. Though one observer can not look into the vacuum tank while watching the galvanometer, at least during the times when a second observer was available, these current pulses were never found to be accompanied by visible sparks between electrodes. Also they were never accompanied by the pronounced outside inductive effects which accompanied regular breakdown - various sparking and noise.

The above pulses were not eliminated by any sort of electrode cleaning before installation in the tank, or by any sort of conditioning in the vacuum. In fact, a hydrogen discharge (to be mentioned later) seemed to increase rather than reduce them. After continuous pumping for as much as a week, they still occurred in the same manner as at the beginning of the period. Hence, it may be concluded that these preliminary current pulses which can be temporarily eliminated but constantly recur in the absence of voltage, must be due to something that gradually collects upon the

electrode surfaces, either contamination in the vacuum system, or material which slowly comes to the surfaces from within the electrodes.

After cessation of the preliminary pulses of current, the voltage across a gap could be raised to a point at which a much steadier current would flow. When attempts were made to determine the relation between this current, voltage, and distance, the apparent resistance of the gap would often abruptly change. Sometimes this would be accompanied by the galvanometer's suddenly dropping to a lower reading, as if a source of conduction had been destroyed or exhausted. At other times the change would be accompanied by the opposite sort of occurrence, a violent swing of the galvanometer and the characteristic noise of breakdown. A third type of change occurred when the galvanometer would start up scale but slowly enough to enable the operator to reduce the voltage before a large current had been reached. This type of change always ended with what has been designated as low-voltage equilibrium.

Following the above experience an attempt was made to determine the current of power at which cathode roughening set in, with a 1-mm gap. At carefully designated spots on a steel plate, current was caused to flow but (with the exception of the unavoidable preliminary pulses) not exceed chosen small values. The smallest of these was 2×10^{-10} amp, at 56 kv. When examined with a 500-power microscope,

all of the test points were found to exhibit the characteristic roughening in at least small areas. Consequently, cathode roughening for steel was either produced by the preliminary pulses or by a steady current as small as 2×10^{-10} amp in the case of a 1-mm gap.

To separate these two effects, experiments were made with the plan of determining through galvanometer readings the range of current or power within which a gap would remain unchanged in characteristics. This work indicated that after allowing some sparking between electrodes there would be a chance of maintaining repetitive conditions with steel for gap lengths up to 15 mm if current was not allowed to exceed 10^{-7} amp. If current can be repeatedly increased to the above limit and then reduced to check previous measurements of voltage and current down to 10^{-10} amp, it would surely seem that cathode contour is not changed by the presence of a current up to 10^{-7} amp. Therefore, the above-mentioned roughening must have been due to the preliminary current pulses.

Measurements of current to the spherical electrodes of this work have been productive of information such as that just given. For quantitative relations, however, such an electrode arrangement is unsuitable. Between a sphere and plane there would be (on the basis of electrode geometry) a single point of maximum gradient where maximum current density would be expected to exist. Outward from this,

current density would decrease in an unknown manner, and total current would thus consist of a summation of edge effect. (For the determination of interelectrode current under more uniform conditions, a guard-ring anode, described on page 138, was later used.)

EFFECT OF ELECTRODE CONDITIONING ON BREAKDOWN VOLTAGE

Along with this work, measurements were taken of breakdown voltages. Since certain of these data were the criteria for the procedure to be followed in more extensive measurements, and show certain sequences not followed in the later work, they are tabulated below. Apparent omissions in these tables, such as the absence of values for untreated stainless steel, are due to the sequences which were considered essential at the time. In this case, fresh cathode regions could not be obtained on one electrode and breakdown was therefore delayed until after the hydrogen discharge in order that current measurements might be made with both electrodes free from the roughening caused by sparking. Such omissions are not present in the work given later in this report.

In order to determine the effect of the individual treatment of the electrodes, data such as that of Table I were taken.

Table I. Breakdown Gradients in Kv per Cm between Nickel Plate and Steel Sphere

	Electrode Separation	
	$\frac{1}{4}$ mm	1 mm
Electrodes untreated	1250	910
Anode conditioned with electron bombardment	1290	860
Cathode conditioned with electron bombardment	980	680
Hydrogen discharge from cathode to shield below anode, with anode disconnected	1960	1280
Hydrogen discharge between electrodes	1980	1250

During electron bombardment, the electrode was brought to and maintained at red heat until the vacuum gages indicated a considerable decrease in the rate of evolution of gas. With the first hydrogen discharge, some parts of the shield became slightly red. With the second discharge, the sphere reached a bright red, and the plate a faint red. Pressure was so adjusted in the neighborhood of a few millimeters to keep the discharge within desired bounds. When the pumping-out process was started, the power source (an 1100-volt transformer with suitable ballast resistance) was left connected to the electrodes. Consequently, during the pumping, the discharge traveled and finally spread throughout the tank before the voltage became insufficient to maintain it. This process of spreading the discharge beyond the electrodes was later discontinued as a preliminary to tests

with the electrodes as it was considered undesirable to dislodge material from the tank walls at such a time. Table I exemplifies what was frequently found to be the case - an electron bombardment of the cathode was detrimental to breakdown voltage. The persistence of the high temperature reached during the bombardment was first suspected, but soon found not to be the cause of this. In fact, the necessary modification in connections was never completed in time to notice a temperature effect. This is in accordance with the work of investigators¹ of field currents, who have found no dependence upon temperature up to 900°K.

In order to study variations of hydrogen-discharge conditioning, data such as that of Table II were taken.

Table II. Breakdown Gradients in Kv per Cm between Nickel Plate and 1-in. Steel Sphere

	Electrode Separation	
	$\frac{1}{4}$ mm	1 mm
Electrodes untreated	1470	1080
Light hydrogen discharge between electrodes	1920	1180
Heavy hydrogen discharge	2000	1110
Prolonged heavy hydrogen discharge	1870	1260
Electron bombardment of both electrodes	2030	1140
After considerable period of breakdown and exposure to high voltage of each polarity		1400

1. Millikan and Eyring, Laws Governing the Pulling of Electrons out of Metals by Intense Fields, Phys. Rev. 27, 1926, p.51.

For the light hydrogen discharge of Table II a current of 0.5 amp (effective value) was used, and the pressure was such that the glow practically covered the flat plate which had an area of 30 sq cm, corresponding to an average density of 0.017 amp per sq cm. This discharge was continued for 3 minutes. For the heavy discharge, a current of 3 amp was used at a pressure which restricted the glow on the flat plate to a 4-cm circle, corresponding to an average density of 0.24 amp per sq cm. Run for 3 minutes, this resulted in the red heat of both electrodes. These adjustments were also used for the prolonged heavy discharge. In this case the discharge was run until the sphere had reached a bright red, and then was discontinued until the sphere had cooled to a dull red. Such a cycle was maintained for a 20-minute period. Besides showing the results of the discharges and electron bombardment, Table II shows the desirable effect of high-voltage breakdown. As will be seen later, however, this often has an adverse effect for closer spacing, probably due to electrode roughening.

Other tables follow, each illustrating some feature which had a bearing on the procedure finally chosen for breakdown tests. The hydrogen discharges below were with conditions similar to those for the above heavy discharge. Also, electron bombarding was in each case continued until red heat had been produced.

Table III. Breakdown Gradients in Kv per Cm between Steel Plate and 1-in. Steel Sphere

	Electrode Separation		
	$\frac{1}{4}$ mm	$\frac{1}{2}$ mm	1 mm
Electrodes untreated	1340	1150	1120
After hydrogen discharge	1780	1660	1250
After electron bombardment of cathode and hydrogen discharge	2600	1950	1280
11 hours later		1810	
After hydrogen discharge		1950	

Table IV. Breakdown Gradients in Kv per Cm between 18-8 Stainless Steel Plate and 1-in. Steel Sphere

	Electrode Separation			
	$\frac{1}{8}$ mm	$\frac{1}{4}$ mm	$\frac{1}{2}$ mm	1 mm
After hydrogen discharge, flat electrode kept negative throughout,				
ascending in gap length	1930	1690	1680	1320
descending in gap length	2290	1920	1540	1250
Ascending, readings with flat electrode negative, but preceded with sparking of each polarity	2510	2210	1840	1410
After electron bombardment of plate	2430	2210	1860	1340
After hydrogen discharge	2530	2100	1650	1350

Table V. Breakdown Gradients in Kv per Cm between 18-8 Stainless Steel Plate and 1-in. Steel Sphere

	Electrode Separation			
	$\frac{1}{8}$ mm	$\frac{1}{4}$ mm	$\frac{1}{2}$ mm	1 mm
After electron bombardment and hydrogen discharge	2520	2200	1670	1270
14 hours later, new spot on cathode	2350	1970	1890	1250

As indicated in Table I, electron bombardment of the anode has little effect on breakdown. That is, breakdown voltage will build up (with sparking) to essentially the same value regardless of whether the anode has been so treated. This would seem to indicate that the processes which precede or accompany breakdown are so effective in cleaning the anode that the effect of heating is submerged. As an example of the effectiveness of this type of cleaning, its removal of films may be cited. Both electron bombardment and the hydrogen discharges have at time been observed to cause the deposition of a colored film upon the electrodes. (This phenomenon has been noted and studied by another investigator.¹) Subsequent breakdown has, especially in the case of the anode, caused this film to be cleared away from the region where sparking occurred.

In the work of Table I, the electron bombardment of the cathode proved detrimental to breakdown voltage, which is a frequent but not universal occurrence (as later data will show). This would suggest that during the bombarding process the cathode became coated with a material which enhanced electron emission.

Table I indicates further that a hydrogen discharge applied only to the cathode will produce practically as

1. R.L.Stewart, Insulating Films Formed Under Electron and Ion Bombardment, Phys. Rev. 45, Apr., 1934, p.488. (Such films were punctured with voltages between 4 and 14 volts.)

great an increase in breakdown voltage as a discharge between electrodes. In this case, however, the discharge surrounded the anode so that, even disconnected, it by no means completely escaped bombardment.

As a consequence of Table II and similar data, a 3-amp discharge over a limited area during a 3-minute period was generally used as the procedure for hydrogen-discharge treatment. After such treatment sparking usually takes place with marked readiness, i.e., there seems to be little tendency for low-voltage equilibrium with the generator. Table II indicates the beneficial result of such sparking and exposure to high voltage (up to 140 kv).

Tables III and V indicate that an electron bombardment of the cathode is a helpful preliminary to a hydrogen discharge. Though the improvement in the former was more than usual, this nevertheless generally seemed to be a desirable sequence. Table III also shows the decrease in breakdown voltage which may occur during a period when the electrodes stand without voltage. The repetition of the hydrogen discharge, however, restored the breakdown voltage to its previous value.

During the first experiments, new surface regions were generally used for each gap length. Later it was found that equivalent results could be obtained if all gaps were taken with the same surfaces, provided variation of gap length was always in the direction of an increase. Since

the reverse variation was found to produce different results, it seemed that measurements should be taken with both ascending and descending directions of gap variation. The difference in the ascending and descending¹ measurements was of course due to the intervening effect of long-gap (high-voltage) breakdown. Another feature, exemplified in Table IV, is the beneficial effect of breakdown with each polarity. This table also indicates that electron bombardment after a hydrogen discharge has little effect.

SPACE-CHARGE EFFECTS

Measurements of leakage current in this investigation were of course limited in value to the current which the generator could produce - about 10^{-4} amp. With the exception of cases of low-voltage equilibrium, however, only a small fraction of this current was measured between electrodes (the bulk of the generator's current was usually taken by the corona leak). As breakdown voltage was approached, the steady current could be increased until the extremely rapid rise of current, representing breakdown, would take place. Of the steady current preceding break-

1. Though the curves of these measurements are designated "ascending and descending" to indicate the direction of variation of gap length, it should not be assumed that they can be repeated in a cyclic manner, as in the case of a hysteresis loop. As the electrode surfaces are undergoing continual changes during breakdown tests, each successive run would in general be expected to differ somewhat from preceding runs.

down, one of the largest observed values was about 10^{-5} amp. For a computation to follow, this current will be assumed; also a gap length of 1 mm and a voltage of 100 kv (which was exceeded for this gap with steel) will be assumed. Further, conduction will be considered to be due entirely to electrons. The velocity which an electron will acquire in falling through this voltage may be computed with the formula¹

$$v = c \sqrt{1 - \left(\frac{1}{\frac{Ve}{mc^2} + 1} \right)^2}$$

in which v = electron velocity in cm/sec,
 c = velocity of light in cm/sec,
 V = potential difference between electrodes
in e.s.u.
 e/m = electron ratio of charge to stationary mass
in e.s.u.

$$v = 3 \times 10^{10} \sqrt{1 - \left(\frac{1}{\frac{10^5 \times 5.3 \times 10^{17}}{300 \times 9 \times 10^{20}} + 1} \right)^2} = 1.64 \times 10^{10} \text{ cm/sec.}$$

If an electron were accelerated between electrodes at a uniform rate, the time required to pass between electrodes would equal distance divided by average velocity, or $t = 2d/v$, in which d and v are respectively distance and final velocity. Since, however, the electron accelerates at a decreasing rate on account of its increase of mass with velocity, the time for it to pass between electrodes will be less than twice interelectrode distance divided

1. Timbie, W. H. and Bush, V., Principles of Electrical Engineering, John Wiley and Sons, 1930, p. 482.

by final velocity, or

$$t < 2 \times 0.1 / 1.64 \times 10^{10} = 1.2 \times 10^{-11} \text{ sec.}$$

A current of 10^{-5} amp corresponds to

$$10^{-5} / 1.6 \times 10^{-19} = 6 \times 10^{13} \text{ electrons per second.}$$

The number of electrons en route between electrodes is less than the product of the above values or less than

$$6 \times 10^{13} \times 1.2 \times 10^{-11} = 720 \text{ electrons.}$$

Thus the total space charge is less than

$$720 \times 4.77 \times 10^{-10} = 3.5 \times 10^{-7} \text{ statcoulomb.}$$

The charge per sq mm on the electrode surfaces is

$$E / 400\pi = 10^6 / 300 \times 400\pi = 2.7 \text{ statcoulombs/mm}^2,$$

in which E is the gradient in statvolts/cm.

Thus the charge on even a square millimeter of electrode surface is about 10^7 times the total space charge. Consequently, the effect of space charge must be very small.

CHAPTER V
BREAKDOWN MEASUREMENTS

PROCEDURE

As a part of this investigation, breakdown measurements were made for a group of metals, following an experimental procedure based upon the preceding experiments. For cathodes, flat pieces of stock were used as before. These were in most cases tested in an unpolished condition, as obtained; and also after commercial polishing and buffing. For anodes, 1-in. spheres of the same material were used whenever practicable, otherwise steel spheres were used. With each pair of electrodes, both ascending and descending¹ tests were made as follows: (1) with no vacuum conditioning, (2) after an electron bombardment of the cathode, and (3) after a hydrogen discharge between electrodes. The results of these measurements are shown in Figs. 9 to 49.

Besides the above work upon different materials, breakdown tests were made with steel electrodes mounted in the compartment directly under the lead-in bushing. The high-voltage electrode used in this case consisted of a steel disk 2 in. in diameter. This covered the lower end of the 2-in. cylindrical high-voltage lead extending down the center of the bushing. Below the center of the disk, the ground electrode, consisting of a 1-in. sphere, was mounted

1. See footnote on page 57.

in a vertically adjustable position. The results of the measurements with these electrodes are shown in Figs. 50 to 58.

The curves of Figs. 9 to 58 are drawn from measurements of voltage applied between electrodes. Points corresponding to voltages which actually produced sparking are indicated with unfilled circles. Points corresponding to the condition which has been designated "low-voltage equilibrium" are indicated with circles filled in solidly. Some points of the latter condition represent voltages which may be somewhat lower than those of the former, parts of the curves connecting opposite types of points were drawn as straight dotted lines unless smooth curves seemed appropriate.

The measurements for Figs. 9 to 58 were taken, unless otherwise indicated, with the high-voltage parts negative, thus making the flat electrode cathode. Also, unless otherwise indicated, measurements were taken after exposure of the electrodes to both polarities in order to secure any improvement thus produced. In cases of repeated sparking, considerable improvement would usually be obtained.

Though the curves in general include the effect of sparking (when it could be produced), some measurements were taken otherwise. For instance, Fig. 16 shows, for polished steel conditioned with a hydrogen discharge, curves of first breakdown values as well as curves after the improvement due to subsequent sparking. Each point of this

figure was of course taken with a fresh cathode spot. On certain of the curve sheets, measurements of first breakdown voltage with a 1-mm spacing are shown with triangular symbols. Since such data require a new cathode region for each point, they are obviously limited in number.

As stated in Chapter IV, breakdown voltages for a range of gap lengths at a single electrode region often depend upon the direction of variation of gap length. To show this effect, both ascending and descending (with respect to gap length) curves have been taken. The direction of variation is indicated with arrow heads on the curves.

The curves of Figs. 9 to 58, labeled V and E, represent respectively voltage and the quotient of voltage and distance. The latter is the average gradient along the shortest line between electrodes. These two quantities are plotted against electrode separation.

CATHODE GRADIENTS

As stated above, the gradient curves of Figs. 9 to 58 represent average values. If surface irregularities are neglected, the plane cathode opposite the spherical anode will have a value of maximum gradient (at the point nearest the sphere) which is related to the plotted value by the lower curve of Fig. 6, page 34. For gaps not exceeding 2 mm, as is the case in Figs. 9 to 16 and some others, this factor does not differ from unity by more than about 5 percent.

For longer gaps, however, this factor becomes appreciably different from unity (as may be seen in Fig. 6), and smooth-surface cathode gradient becomes appreciably lower than the plotted curves of average gradient.

MEASUREMENTS AND DISCUSSION

The results of measurements between cold-rolled strip steel and 1-in. chrome-steel spheres are shown in Figs. 9 to 16, pages 69 to 76. A comparison of Figs. 9 and 12 indicates that, after sparking with long gaps, the effect of polishing and buffing is lost - a result that would be expected after seeing the manner in which the plates had been roughened by sparking.

Figs. 10 and 13 on pages 70 and 73 indicate that the combination of polishing and buffing and an electron bombardment is detrimental - due likely to imbedded material which heating may have brought to the surface. Figs. 11 and 14, pages 71 and 74, indicate that a similar statement may be made for tests following a hydrogen discharge. Also in this case the polished plate was much more injured by high-voltage sparking. The unpolished plate, incidentally, reached one of the highest gradients of this investigation, 2500 kv per cm.

Fig. 15 on page 75 shows the results of an a-c flash-over, using equipment described in connection with Fig. 54. The results of subsequent d-c measurements are also plotted,

and indicate an unusual occurrence. Higher voltages were obtained with the sphere as cathode, in which case it would have at the same voltage and especially with the longer gaps an appreciably higher gradient than the plane, on the assumption of smooth surfaces. (See Fig. 6, page 34.) As a possible explanation, this may be attributed to the greater concentration on the sphere of the a-c flashover. After this test the sphere was found to have been flattened by actual removal of material so that through the center of the test region the diameter had been reduced 3.8 mils.

In order to show the voltages and gradients at which breakdown starts, a polished and buffed steel plate was conditioned with a hydrogen discharge. Using a new cathode point for each test, such values were determined. The measurements were in each case followed by sparking until improvement ceased, when values were again read. These results are plotted in Fig. 16, page 76.

The curves for stainless steel (18 percent chromium and 8 percent nickel), shown in Figs. 17 to 22 on pages 77 to 82, differ but little from the preceding steel. Before conditioning those of the stainless steel were somewhat lower at long gaps; for which reason these curves were carried beyond 2 mm. After the hydrogen discharge, however, the difference had practically disappeared except for the shortest gaps, where stainless steel remained lower.

The curves of Figs. 23 to 25, pages 83 to 85, for a

chromium-plated steel plate and a steel sphere are definitely below those of either steel. They are characterized by a wide divergence between ascending and descending curves; and by a number of filled points (indicating low-voltage equilibrium) on the latter, which is consistently the lower curve in this case. This would indicate that sparking caused the chromium surfaces to deteriorate as insulating electrodes.

The results for nickel, in Figs. 26 to 31 on pages 86 to 91, are similar but slightly inferior to those for chromium. The electron bombardment of polished nickel seemed especially disastrous, limiting gradients to 450 kv per cm even with a 0.25-mm gap. This necessitated changing plates, after which data were taken for the curves of Fig. 30, page 90, representing values for the first and second sparks on a succession of new cathode regions. After a hydrogen discharge, data were taken for first-breakdown voltages, and voltages after improvement had ceased.

In the order of inferiority, the next results were for a molybdenum plate and a steel sphere, for which curves are shown in Figs. 32 to 34, pages 92 to 94.

The next curves are for a group of metals, monel, copper, and aluminum, which were found to be the poorest of the electrode materials tested from the viewpoint of this work. With monel, Figs. 35 to 40, pages 95 to 100, it was difficult to produce sparking, and sparking was found to have little effect on subsequent measurements, to cause almost

no external inductive effects, and to produce very little marking of the electrodes. Also, especially with unpolished monel, neither an electron bombardment nor a hydrogen discharge had much effect. For the short gaps, polishing proved to be quite beneficial.

The results for copper, in Figs. 41 to 45, pages 101 to 105, were similar in character but slightly poorer in magnitude than those of monel. The electron bombardment of copper was productive of unusual quantities of gas, and was followed by very low gradients which, however, improved with exposure to high voltage.

The lowest voltages and gradients of this series were, on the whole, obtained with aluminum for which curves are shown in Figs. 46 to 49, pages 106 to 109. Though a single point of 1200 kv per cm was observed at the very short gap of 0.125 mm, such a value was not again obtained. After polishing, the gradients remained curiously constant in a range a little above 200 kv per cm. The aluminum electrodes would spark only at the longer gap lengths, and sparking seemed to have little effect on subsequent measurements.

Measurements were made with a cathode consisting of a steel plate covered with baked enamel and an anode consisting of an unenameled steel sphere. The thickness of the layer of enamel on the cathode was about 10 mils; and separation measurements for the tests were made from the outside of the enamel surface. A different cathode region

was of course used for each test. At each test position, the enamel was punctured badly enough to expose to view a small spot of the underlying metal. Table VI gives the voltages and average gradients at which this occurred.

Table VI. Breakdown Voltages and Gradients versus Electrode Separation, for Cathode Consisting of Steel Plate Covered with Baked Enamel and Anode Consisting of 1-in. Unenameled Steel Sphere

Mn	Kv	Kv/Cm
0.25	22.7	910
0.5	30.7	615
1.0	65	650
2.0	110	550

The results of tests made with steel electrodes mounted under the porcelain lead-in bushing are shown in Figs. 50 to 58, pages 110 to 118. Before the installation of the compartment to provide a vapor-free region about these electrodes, a descending test was run after a hydrogen discharge and considerable high-voltage sparking. The results of this are plotted in Fig. 50, page 110. The actual rise of voltage with a decrease of gap length was at first attributed to a shrinking of the region of strong field away from the edge of the disk-shaped cathode as the gap was decreased from 3 to 2 cm. The fact, however, that this phenomenon disappeared with continued use of the electrodes (as can be seen by referring to succeeding curves) would suggest that

shrinking of strong field was not from the edge of the cathode but from outer rings of the test region which had during sparking been less thoroughly conditioned than the central portion.

All of the remaining tests with electrodes under the lead-in bushing were made with the compartment for the screening-out of vapors. (See Fig. 8, page 40.) Fig. 51, page 111, is for new steel electrodes and represents the effect of sparking with the plate as cathode throughout. Fig. 52 is an ascending curve taken after those of Fig. 51, and rises to a considerably higher voltage. For Fig. 53 the electrodes were still not conditioned (except by sparking); but in this case sparking was allowed with each polarity before taking readings (with the plate negative). Except for long gaps, ascending and descending curves closely coincided. In the long-gap range, these curves excel their predecessors, but below 2.15 cm the opposite relation exists.

The next experiments with these electrodes involved breakdown with a-c power from a 50-kv, 15-kva transformer, with a 2.5-megohm resistance in its high-voltage lead. Voltage control was by means of an induction regulator, and voltage measurements were obtained from a voltmeter coil. The 60-cycle impedance angle of the series circuit, formed by the 2.5-megohm resistance and the 110- μ f capacitance of the parts beyond, was 84 deg. On the assumption sinusoidal values (before breakdown), voltage across the

electrodes was therefore within about 0.5 percent of the secondary terminal voltage.

The most striking feature of the a-c work was the evidence of much more powerful breakdown than that produced by the belt generator. The extraneous sparking caused by induction was more extensive and noisier. Power arcs were regularly started between the base of the metal diffusion pump and its heater element, a place where this had not previously occurred (and which necessitated a temporary change to gas heat). Factors on which the strength of a breakdown surge must depend are the amount of stored potential energy and the manner in which the apparent resistance of the test gap varies with time. The capacitance (beyond the 2.5-megohm resistance) with the a-c tests was more than that with the accompanying d-c tests; but it was not more than had been tried with the latter, without producing evidence of such powerful breakdown. Consequently, during the a-c tests, the apparent resistance of the test gap must have more rapidly decreased during breakdown.

To account for a difference in gap behavior in the a-c and d-c tests, two points of contrast may be considered.

NOTE CONCERNING PAGING

In order that they may be more readily compared with each other, Figs. 9 to 58 are grouped together on the following pages, 69 to 118.

The above discussion continues on page 119.

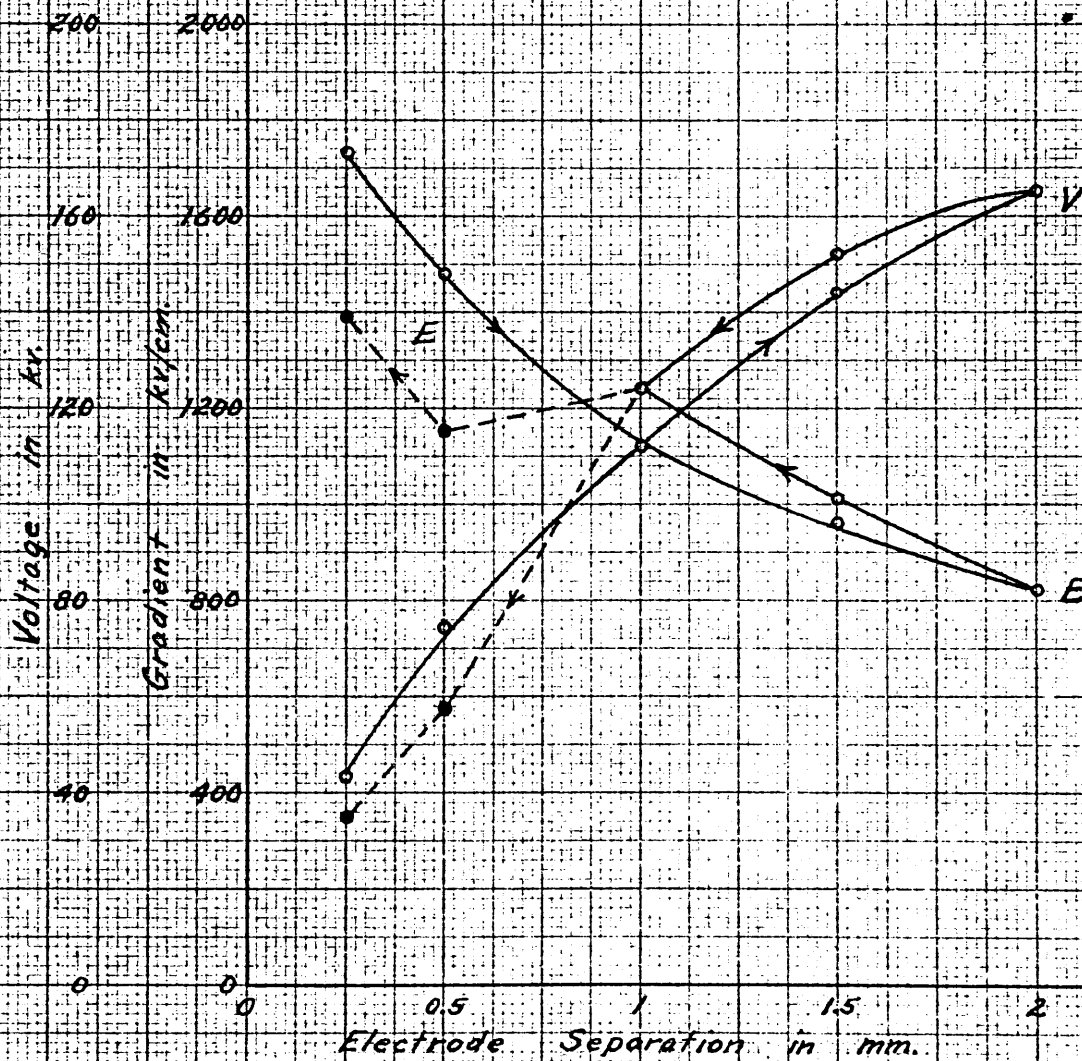

Fig. 9. Voltage and gradient after initial sparking versus electrode separation

Steel electrodes

Cathode, 42-mil plate, unpolished
Anode, 1-in. sphere

Electrodes not conditioned

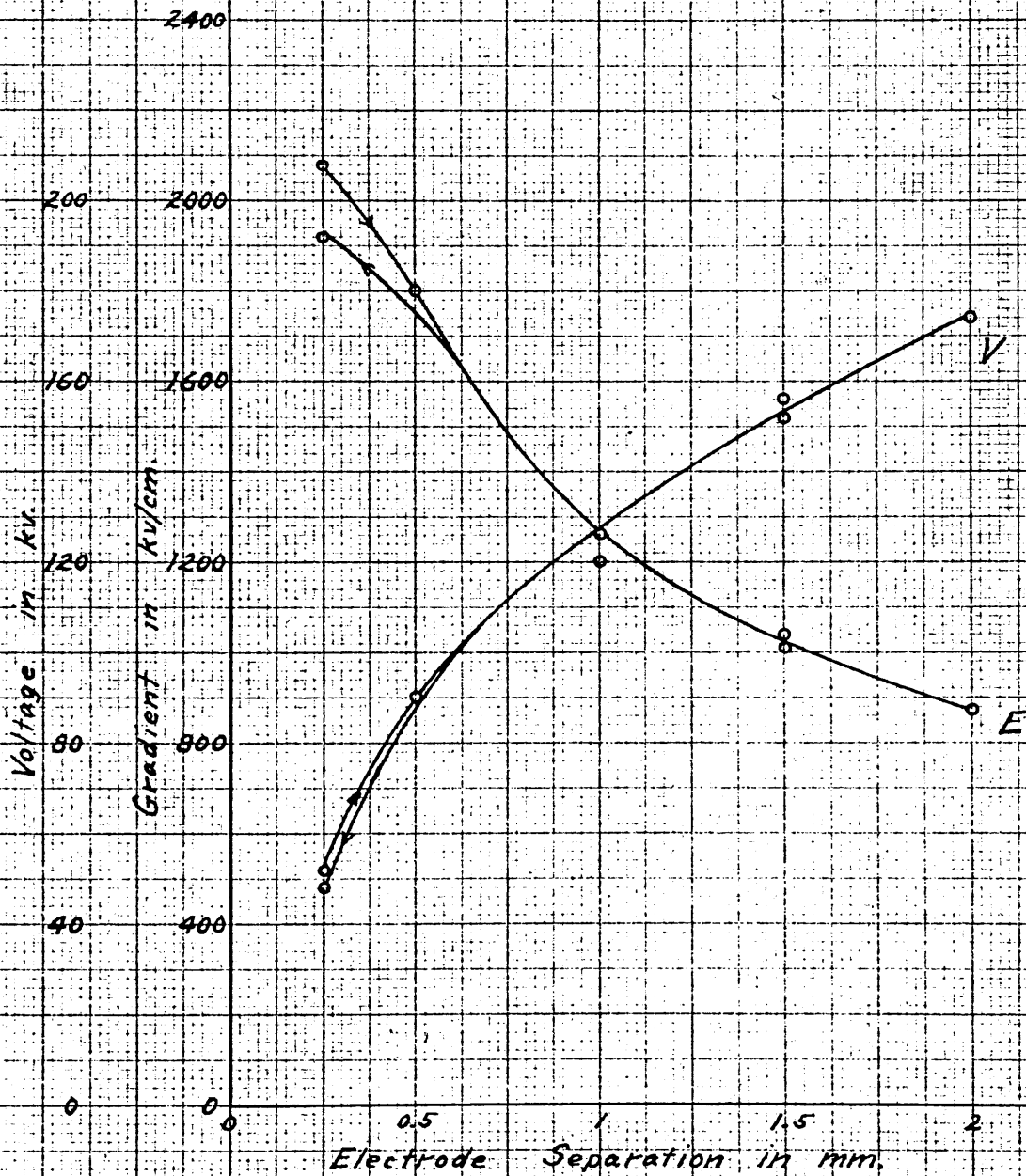

Fig. 10. Voltage and gradient after initial sparking
versus electrode separation

Steel electrodes

Cathode, 42 mil plate, unpolished

Anode, 1-in. sphere

Cathode conditioned with electron bombardment

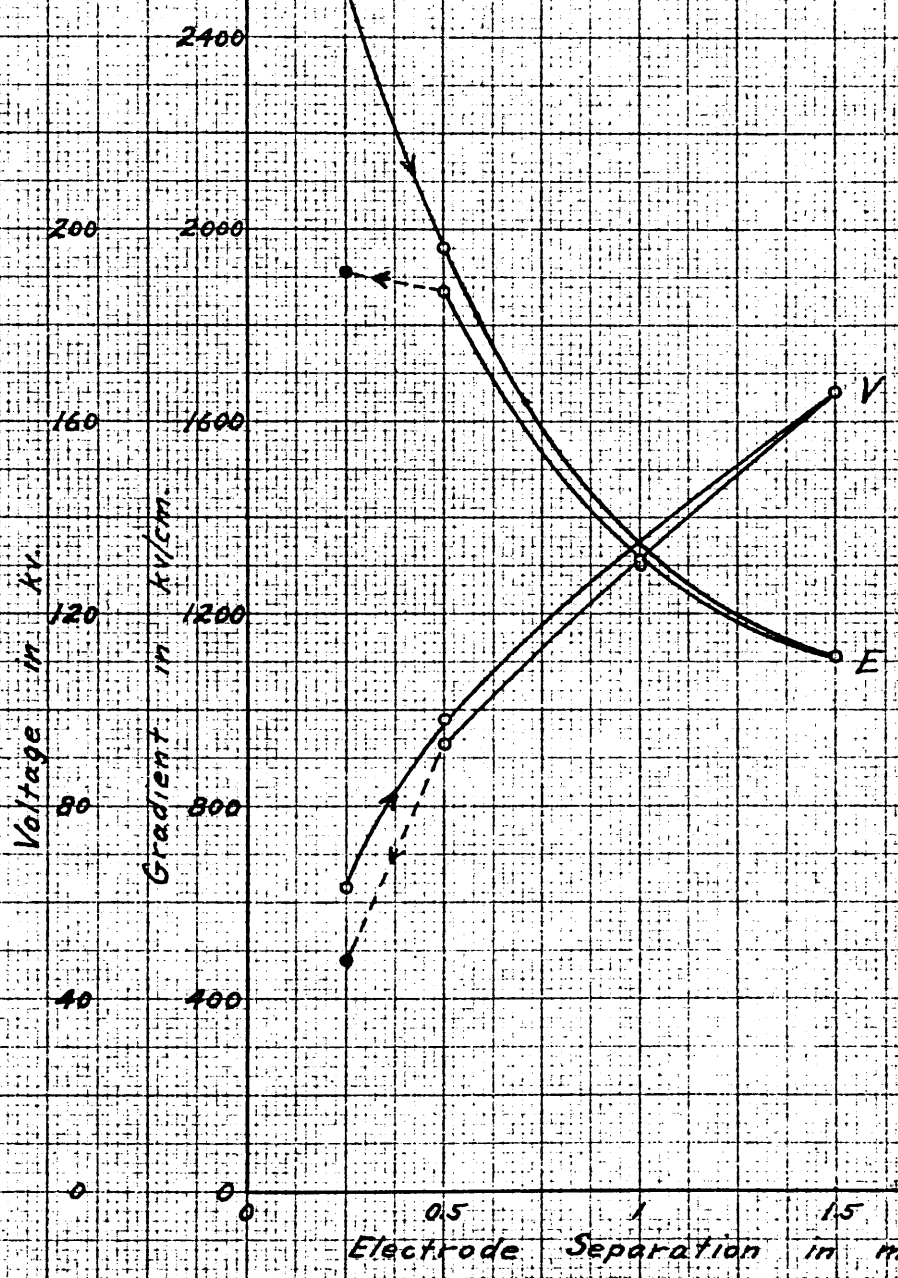

Fig. 11. Voltage and gradient after initial sparking versus electrode separation

Steel electrodes

Cathode, 42-mil plate, unpolished
 Anode, 1-in. sphere

Electrodes conditioned with hydrogen discharge

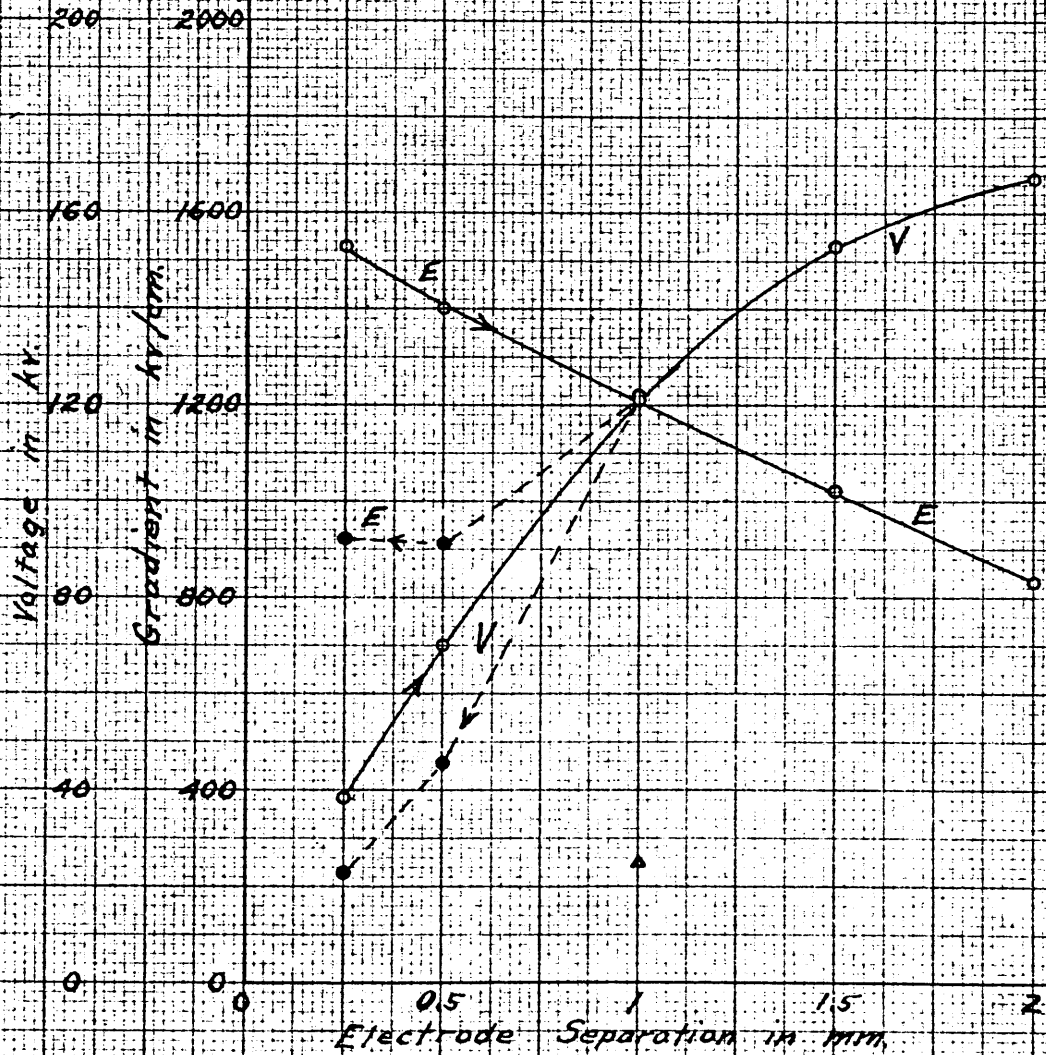

Fig. 12. Voltage and gradient after initial sparking versus electrode separation

Steel electrodes

Cathode, 42-mil plate, polished and buffed
Anode, 1-in. sphere

Electrodes not conditioned

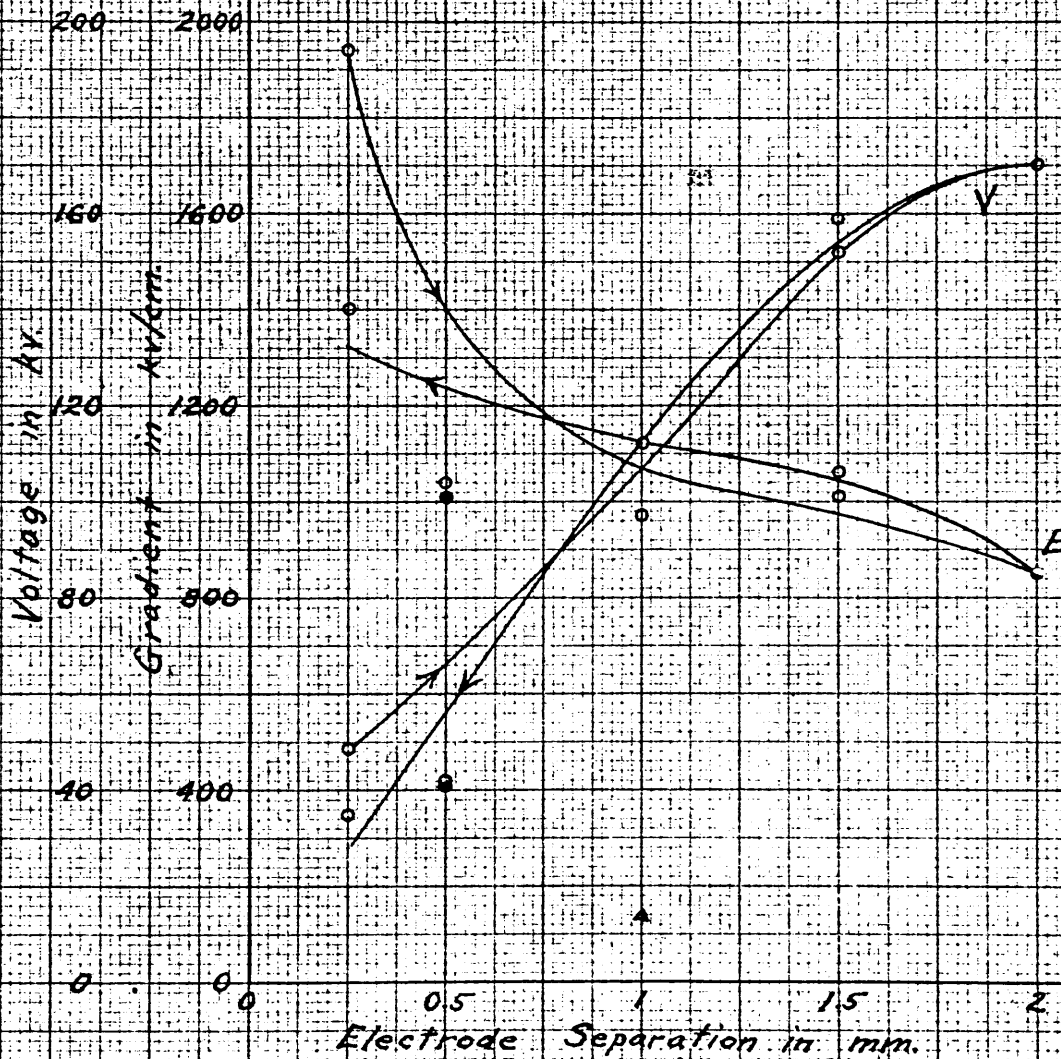

Fig. 13. Voltage and gradient after initial sparking versus electrode separation

Steel electrodes

Cathode, 42-mil plate, polished and buffed

Anode, 1-in. sphere

Cathode conditioned with electron bombardment

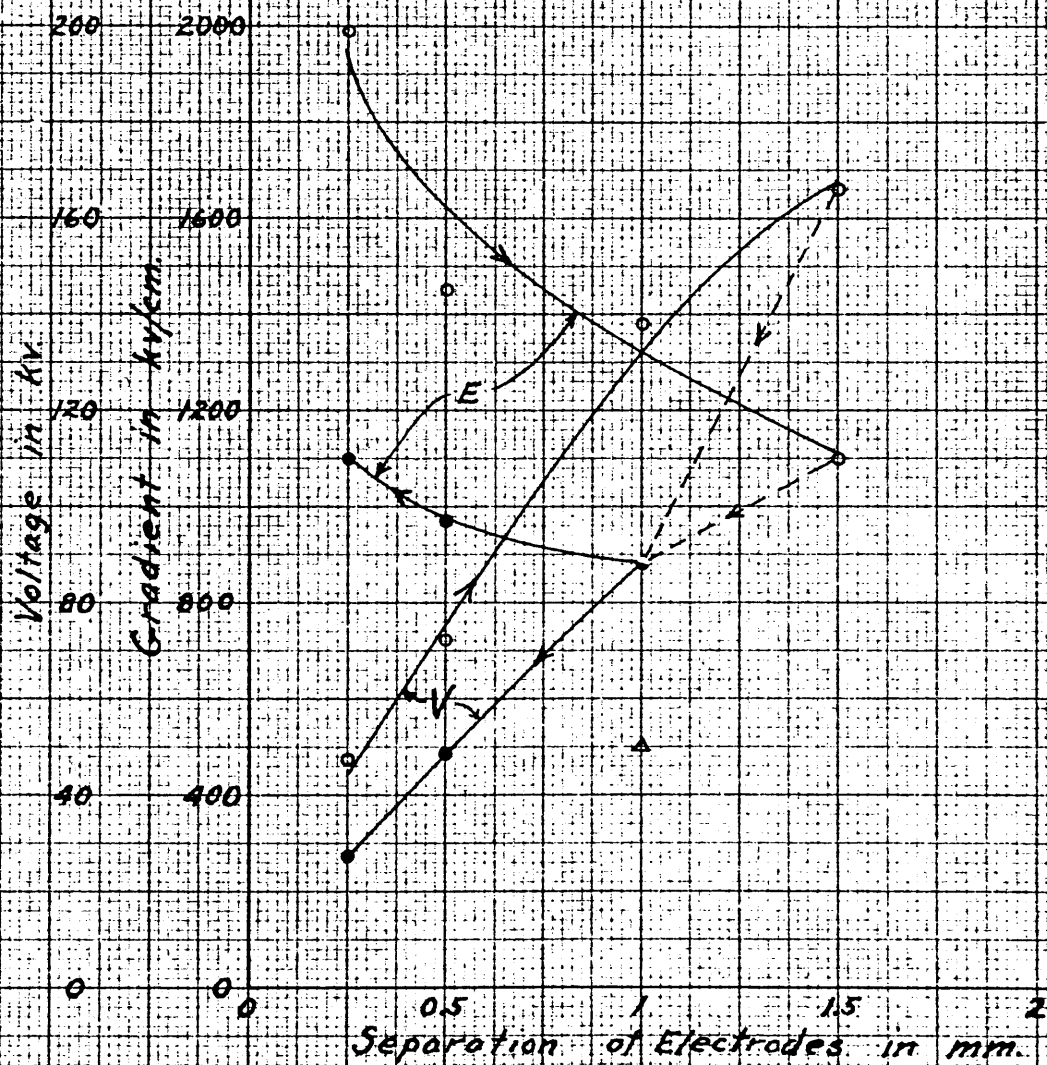

Fig. 14. Voltage and gradient after initial sparking
versus electrode separation

Steel electrodes

Cathode, 42-mil plate, polished and buffed

Anode, 1-in. sphere

Electrodes conditioned with hydrogen discharge

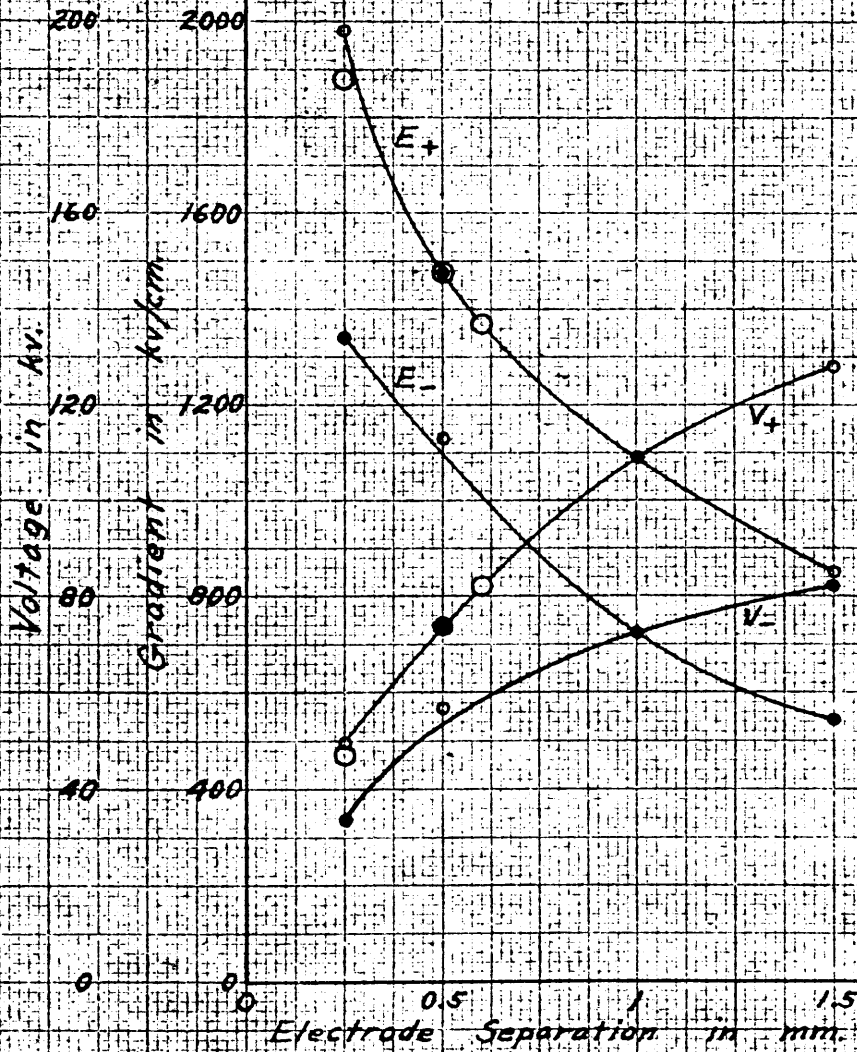

Fig. 15. Voltage and gradient after initial sparking versus electrode separation

Large circles, a-c points

Subscripts indicate polarity of plate

Steel electrodes; 42-mil plate, unpolished
1-in. sphere

Electrodes not conditioned

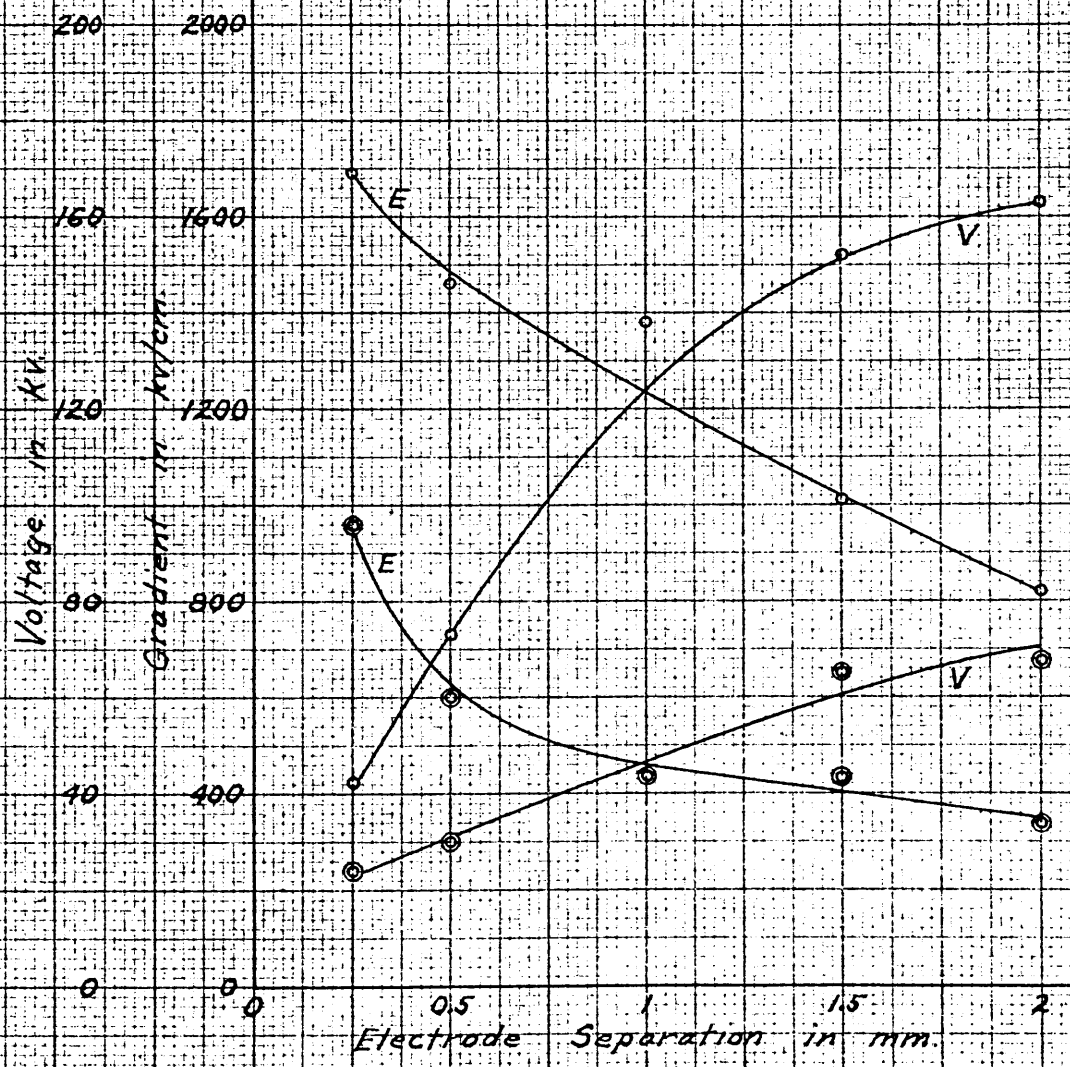

Fig. 16. Voltage and gradient vs electrode separation

Double circles, first breakdown
 Single circles, after improvement due to sparking

Steel electrodes: 42-mil plate, polished and buffed
 1-in. sphere

Electrodes conditioned with hydrogen discharge

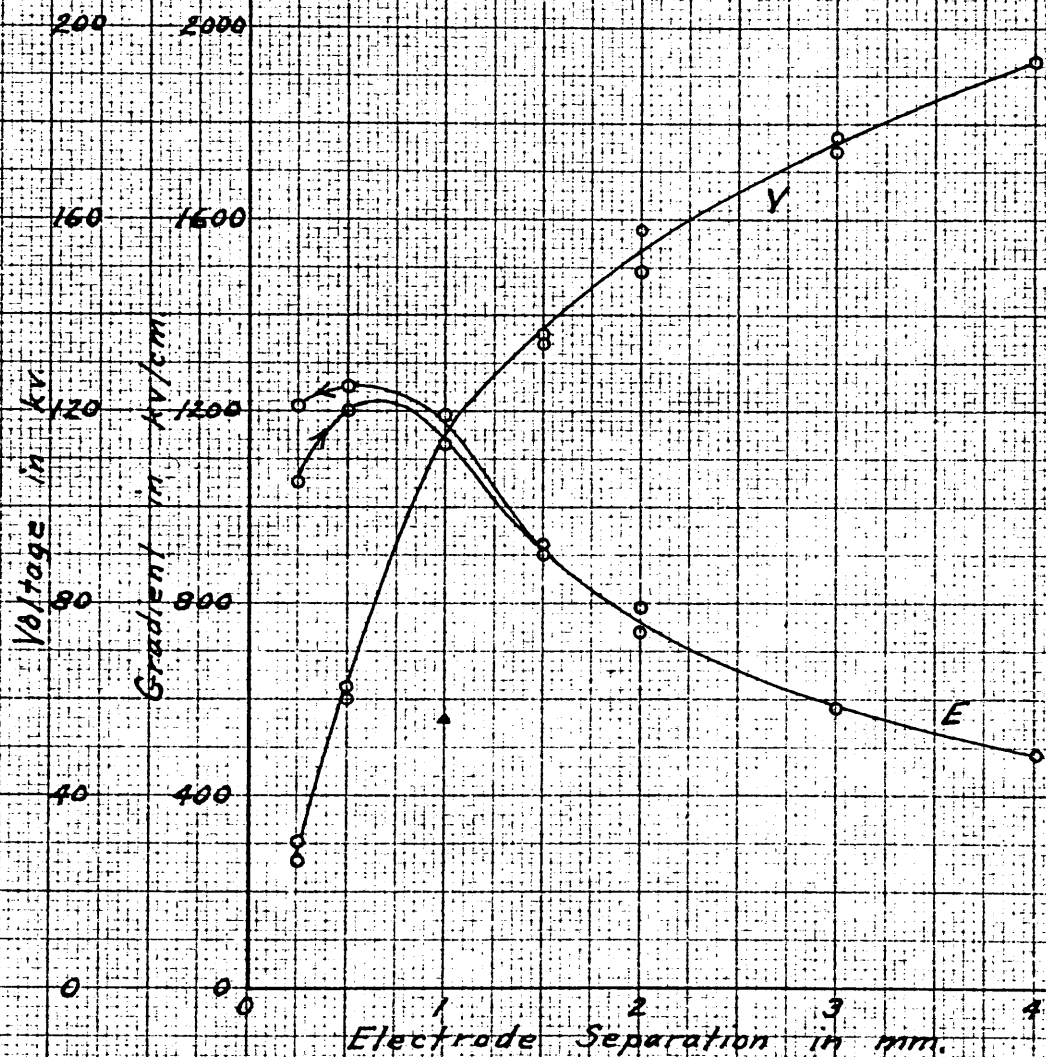

Fig. 17. Voltage and gradient after initial sparking versus electrode separation

Stainless steel electrodes

Cathode, 45-mil plate, unpolished
Anode, 1-in. sphere

Electrodes not conditioned

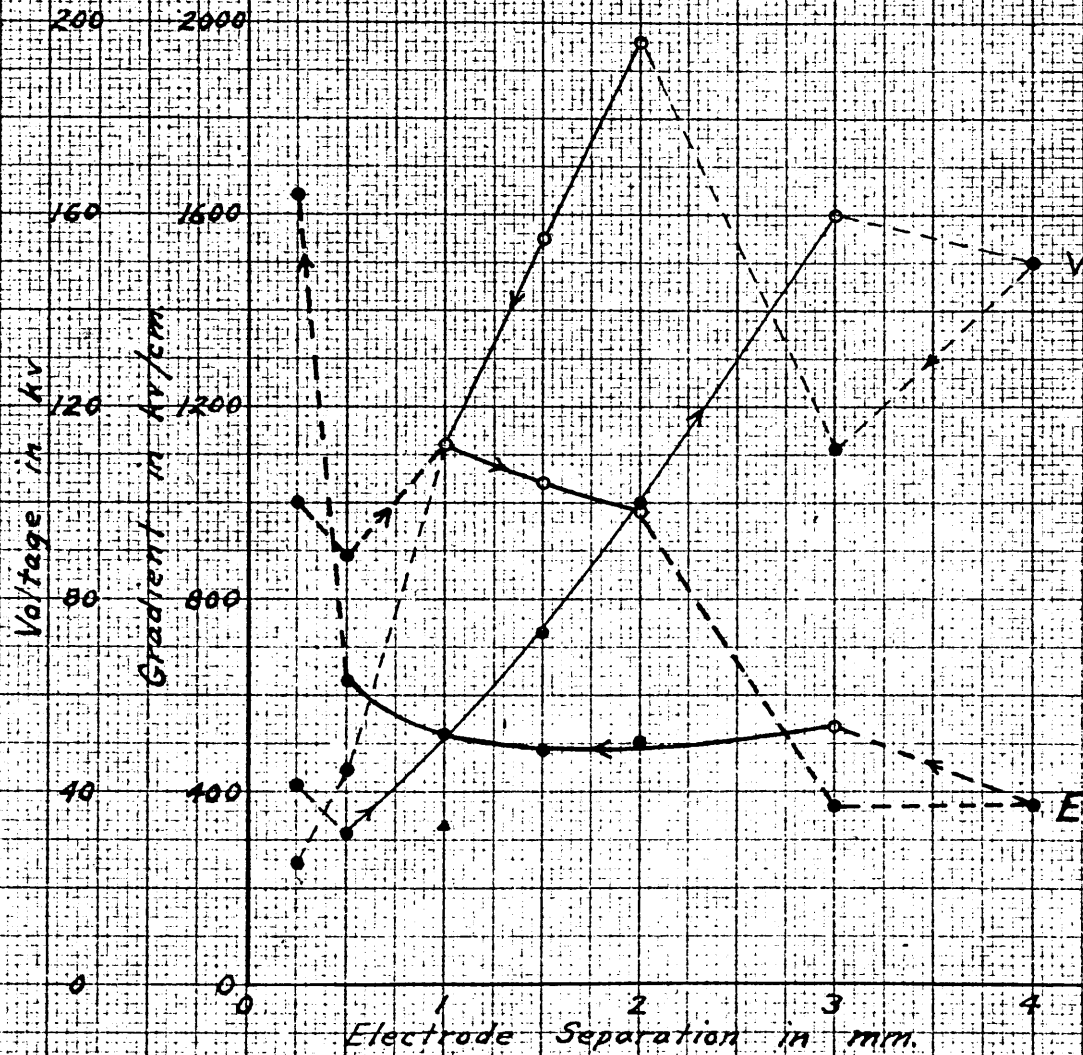

Fig. 18. Voltage and gradient after initial sparking versus electrode separation

Stainless steel electrodes

Cathode, 45-mil plate, unpolished
Anode, 1-in. ball

Cathode conditioned with electron bombardment

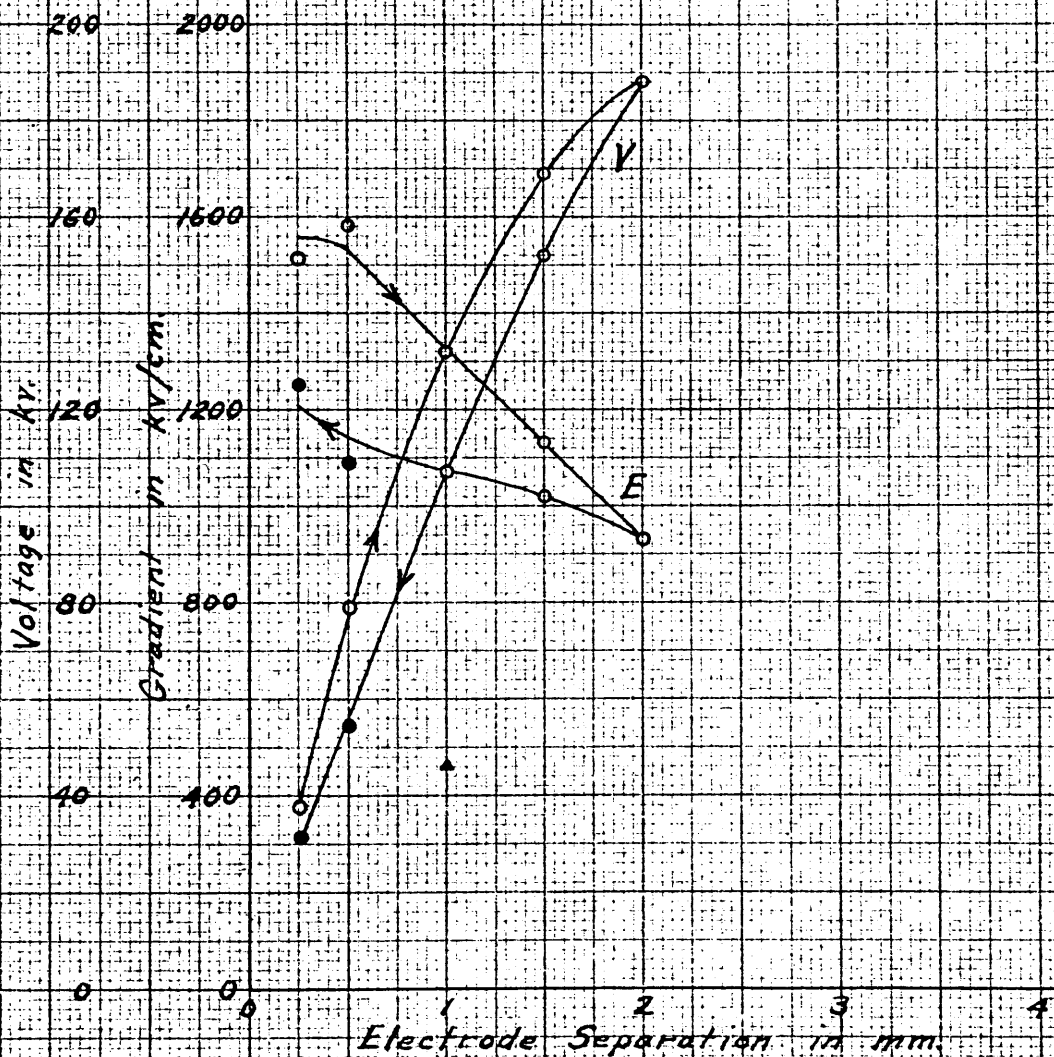

Fig. 19. Voltage and gradient after initial sparking versus electrode separation

Stainless steel electrodes

Cathode, 45-mil. plate, unpolished

Anode, 1-in. sphere

Electrodes conditioned with hydrogen discharge

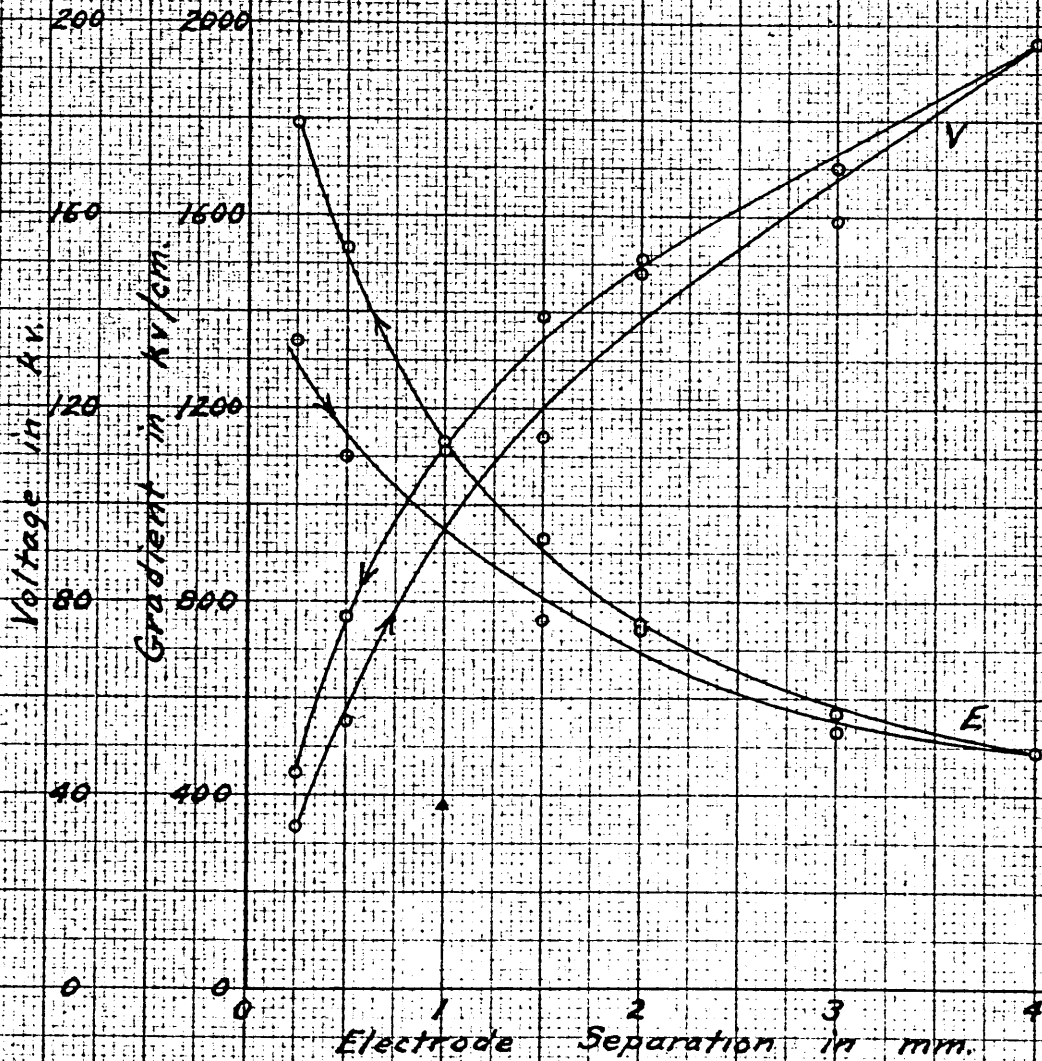

Fig. 20. Voltage and gradient after initial sparking versus electrode separation

Stainless steel electrodes

Cathode, 45-mil plate, polished and buffed
Anode, 1-in. sphere

Electrodes not conditioned

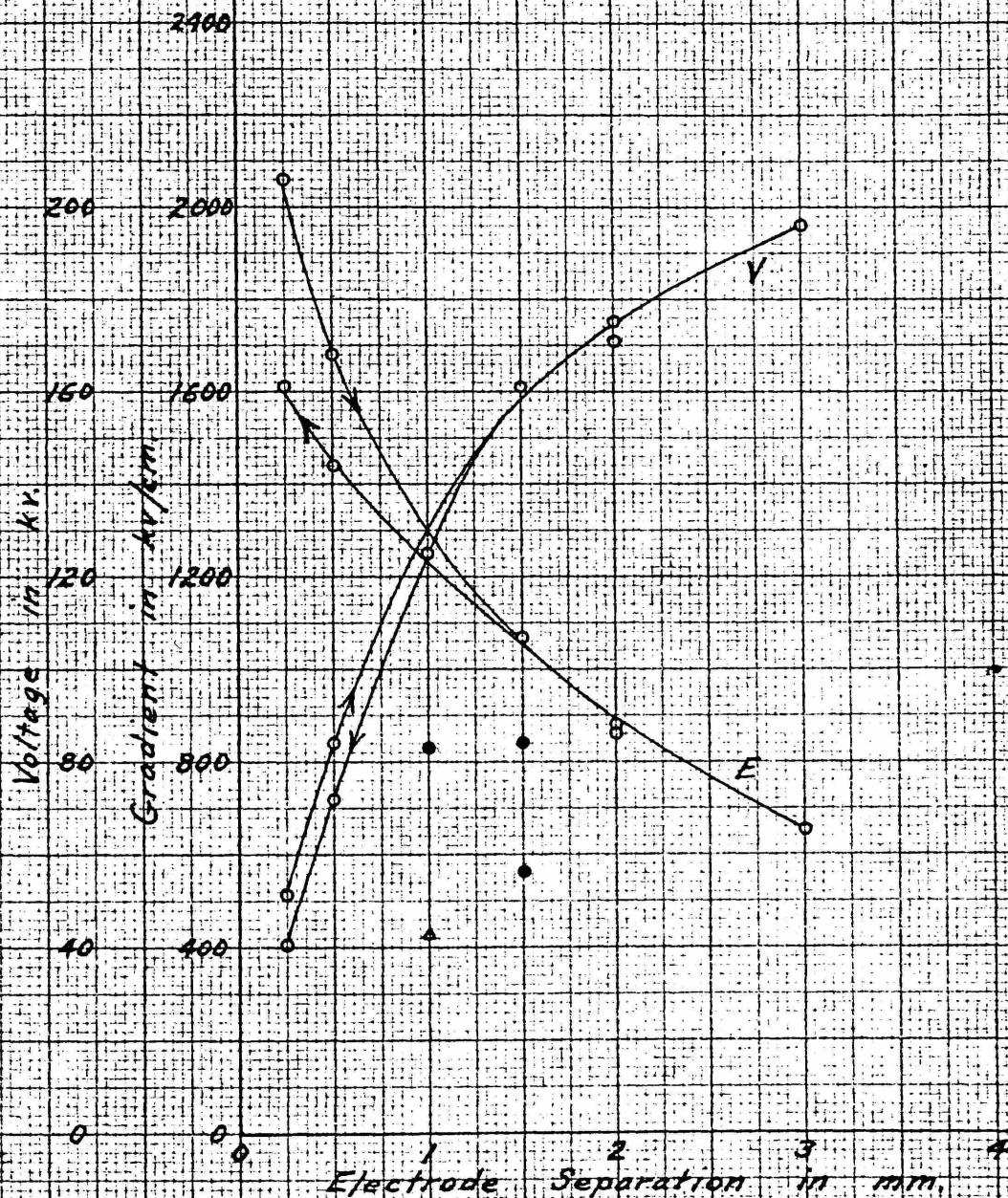

Fig. 21. Voltage and gradient after initial sparking versus electrode separation

Stainless steel electrodes

Cathode, 45-mil plate, polished and buffed

Anode, 1-in. sphere

Cathode conditioned with electron bombardment

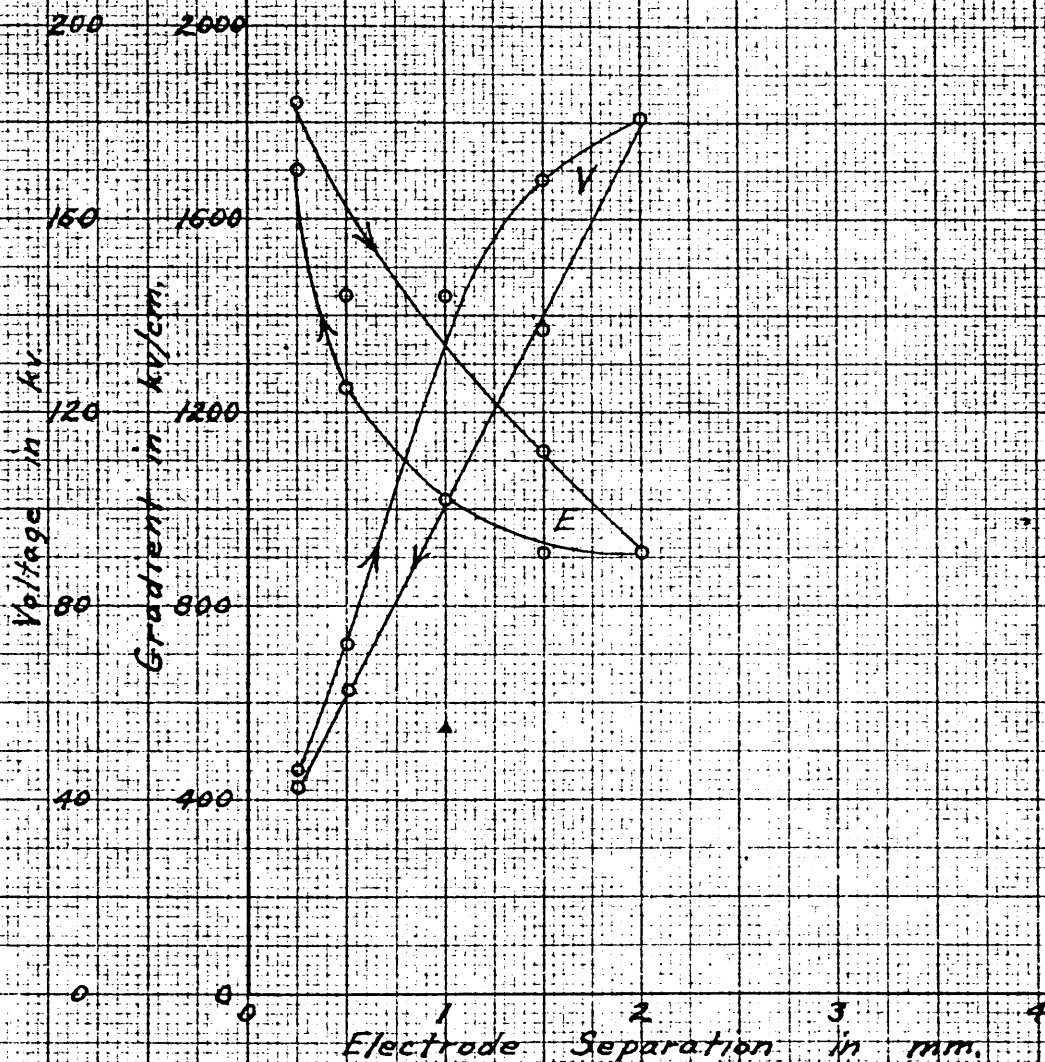

Fig. 22. Voltage and gradient after initial sparking
versus electrode separation

Stainless steel electrodes

Cathode, 45-mil plate, polished and buffed
Anode, 1-in. sphere

Electrodes conditioned with hydrogen discharge

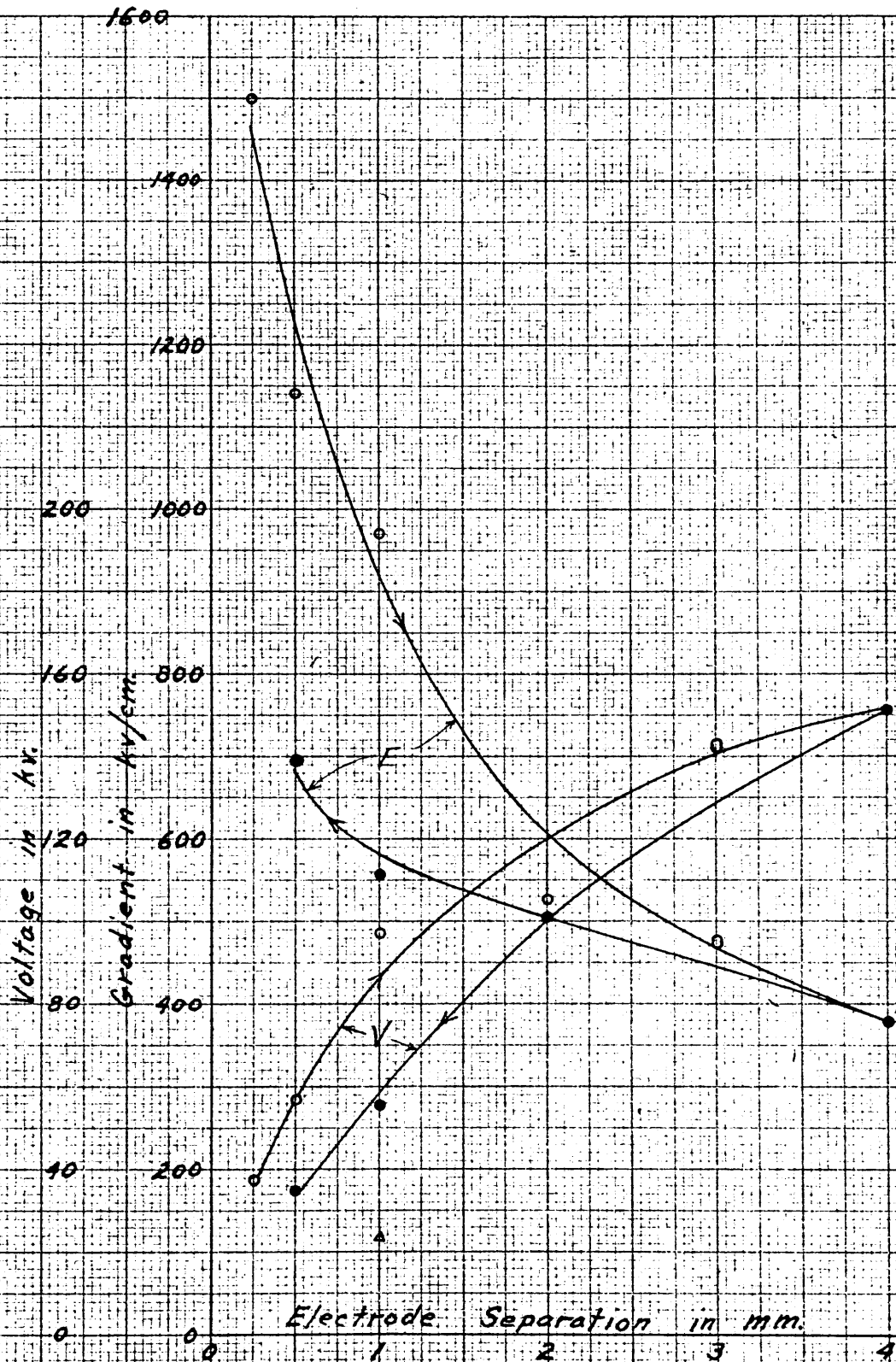

Fig. 25. Voltage and gradient after initial sparking versus electrode separation

Cathode, chromium-plated steel, polished and buffed.
Anode, 1-in. steel sphere

Electrodes not conditioned

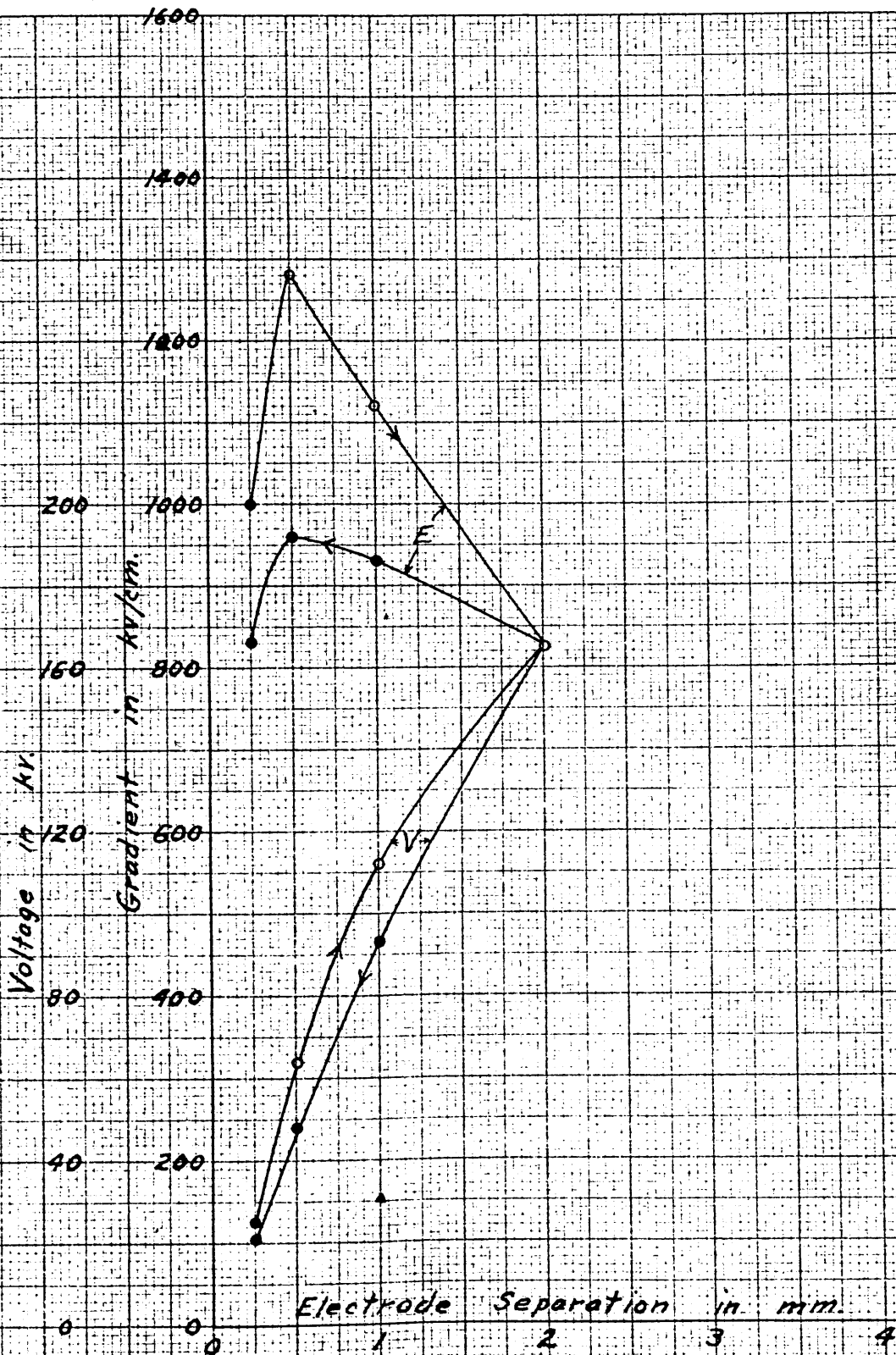

Fig. 24. Voltage and gradient after initial sparking versus electrode separation

Cathode, chromium-plated steel, polished and buffed
 Anode, 1-in. steel sphere

Cathode conditioned with electron bombardment

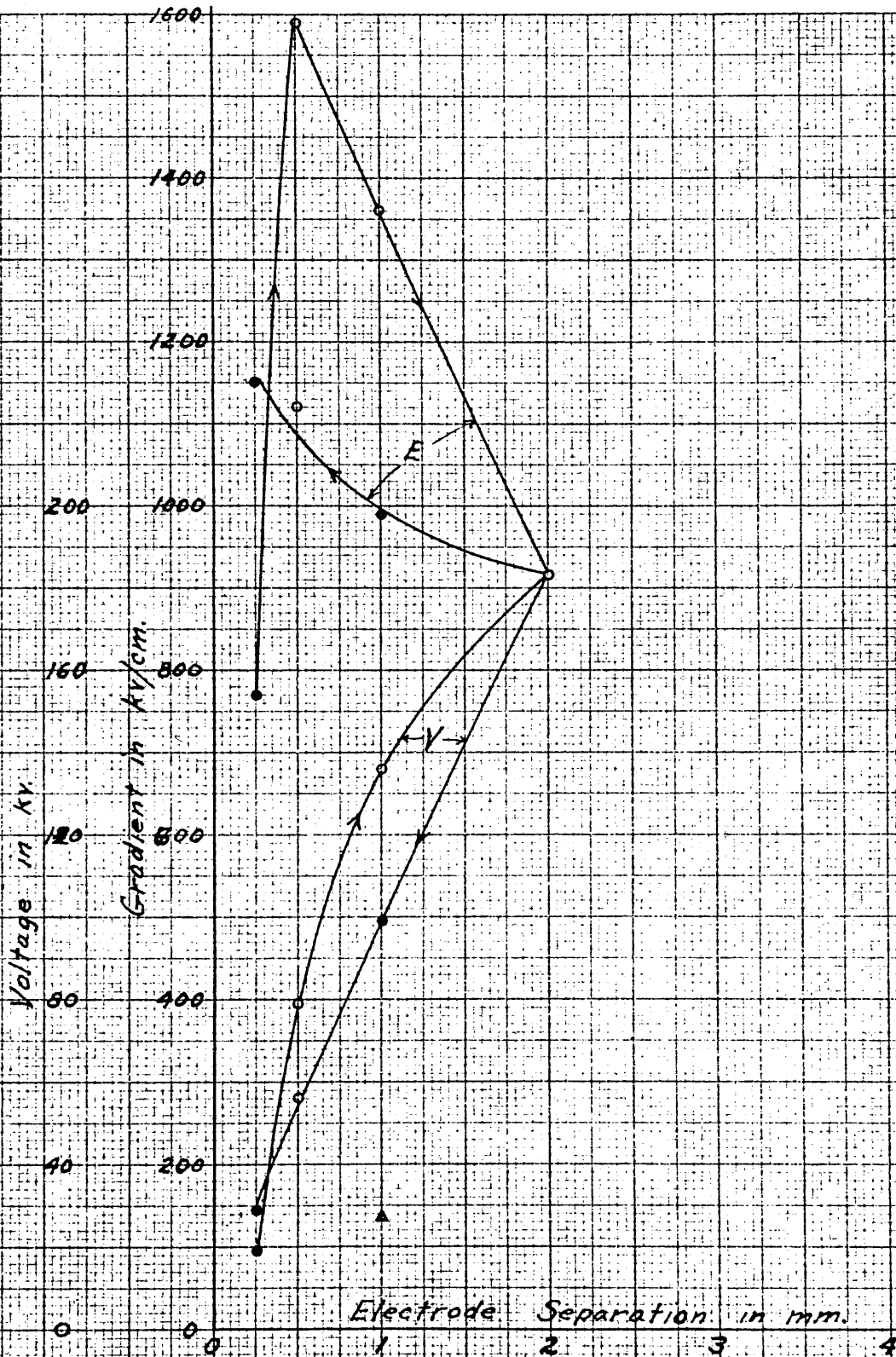

Fig. 25. Voltage and gradient after initial sparking versus electrode separation

Cathode, chromium-plated steel, polished and buffed
Anode, 1-in. steel sphere

Electrodes conditioned with hydrogen discharge

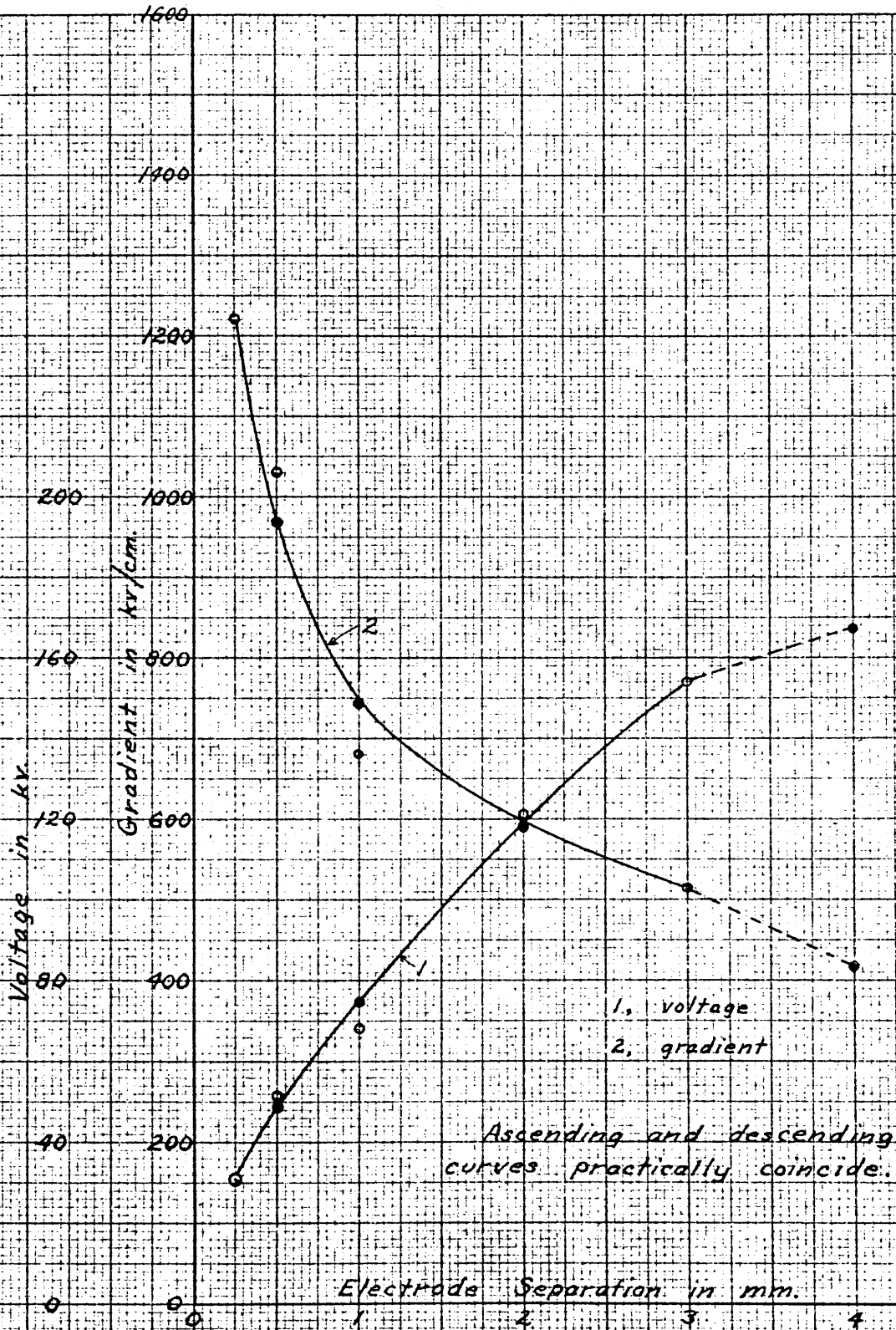

Fig. 26. Voltage and gradient after initial sparking versus electrode separation

Cathode, nickel, 31-mil plate, unpolished

Anode, nickel, 1-in. rod with hemispherical end

Electrodes not conditioned

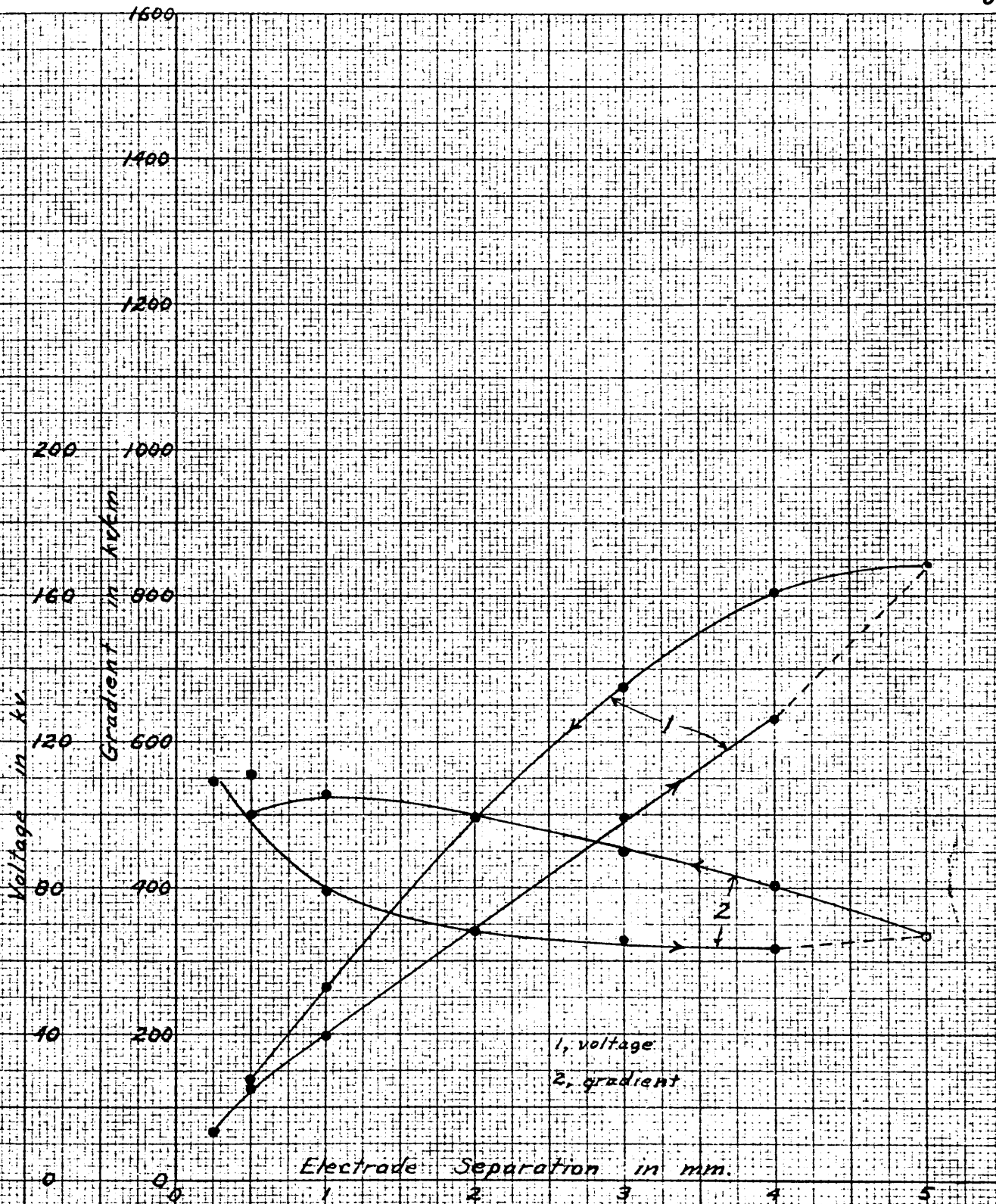

Fig. 27. Voltage and gradient after initial sparking versus electrode separation

Cathode, nickel, 31-mil plate, unpolished
 Anode, nickel, 1-in. rod with hemispherical end
 Cathode conditioned with electron bombardment

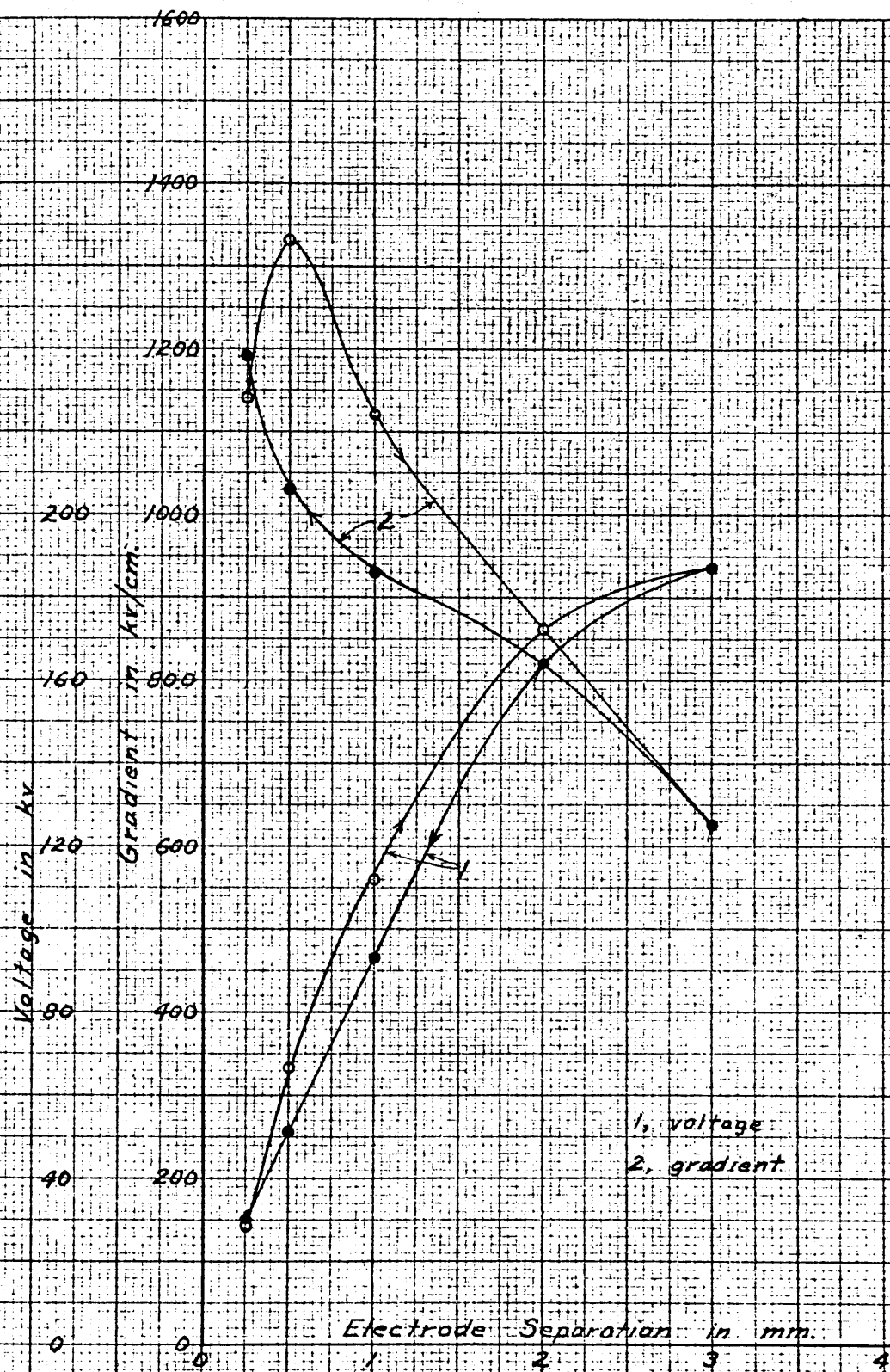

Fig. 28. Voltage and gradient after initial sparking versus electrode separation

Cathode, nickel, 31-mil plate, unpolished
 Anode, nickel, 1-in. rod with hemispherical end

Electrodes conditioned with hydrogen discharge

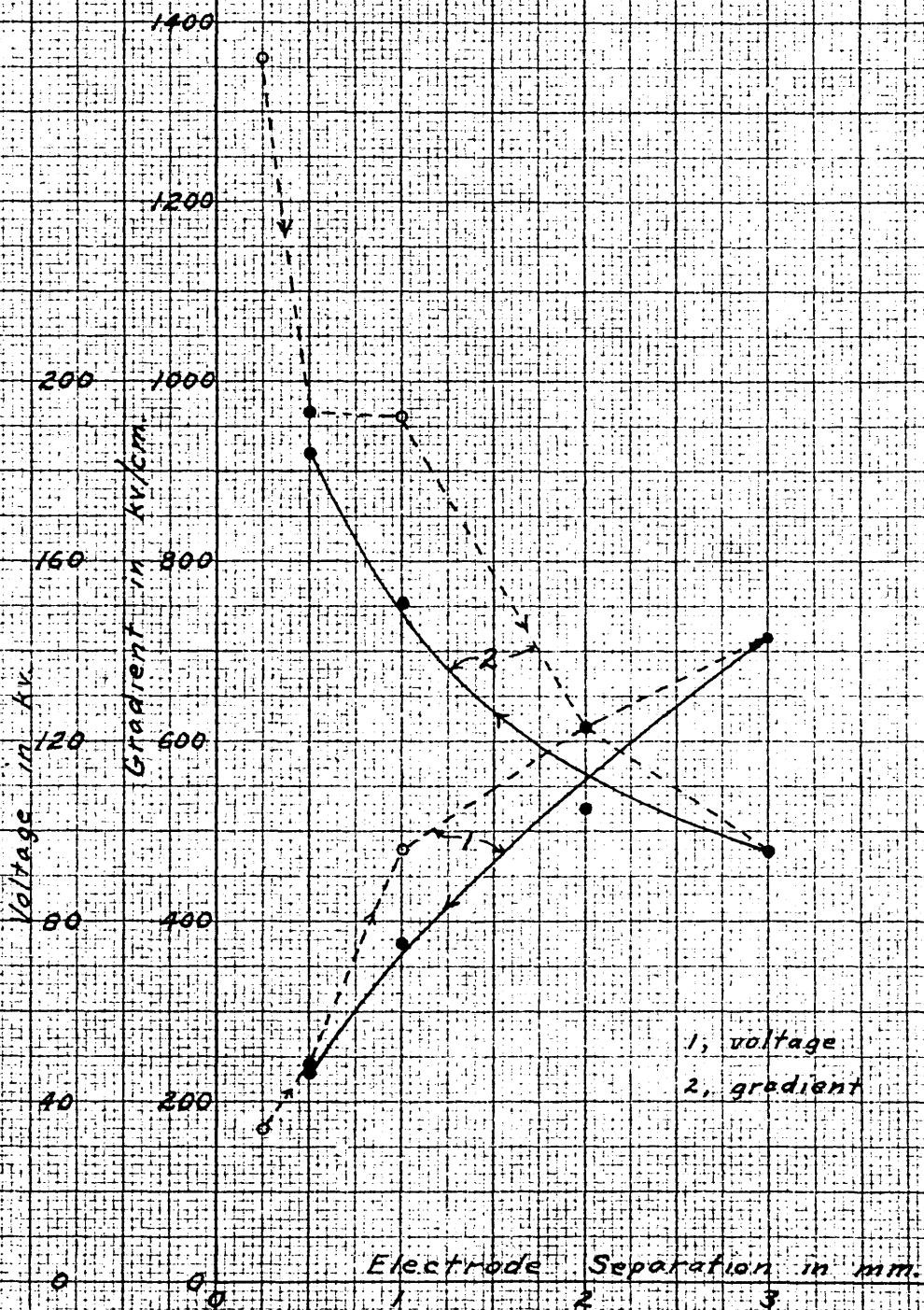

Fig 29. Voltage and gradient after initial sparking versus electrode separation.

Cathode, nickel, 5l-ml plate, polished and buffed
 Anode, nickel, 1-in. rod with hemispherical end

Electrodes not conditioned

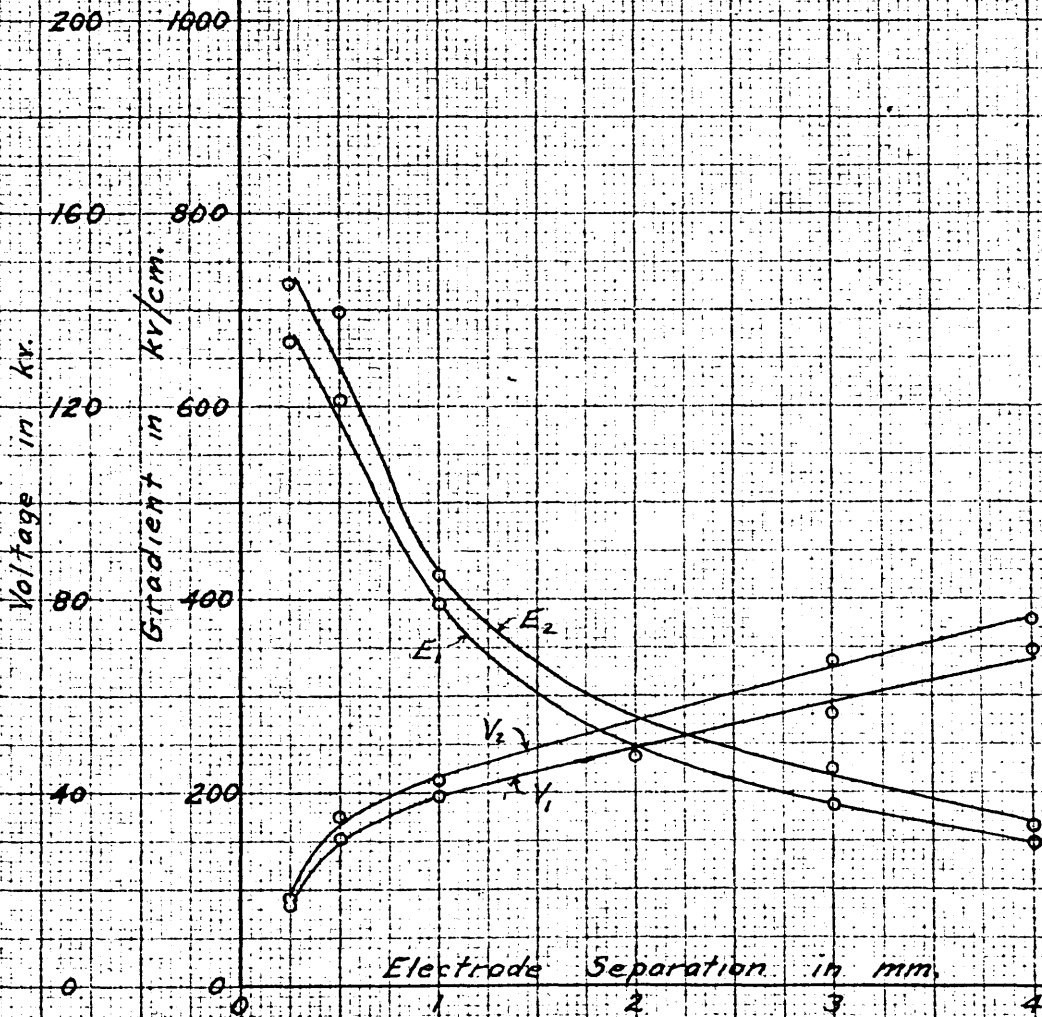

Fig. 30. Voltage and gradient vs electrode separation

Subscript 1, first breakdown
 Subscript 2, second breakdown

Cathode, nickel, 31-mil plate, polished and buffed
 Anode, nickel, 1-in. rod with hemispherical end

Electrodes not conditioned

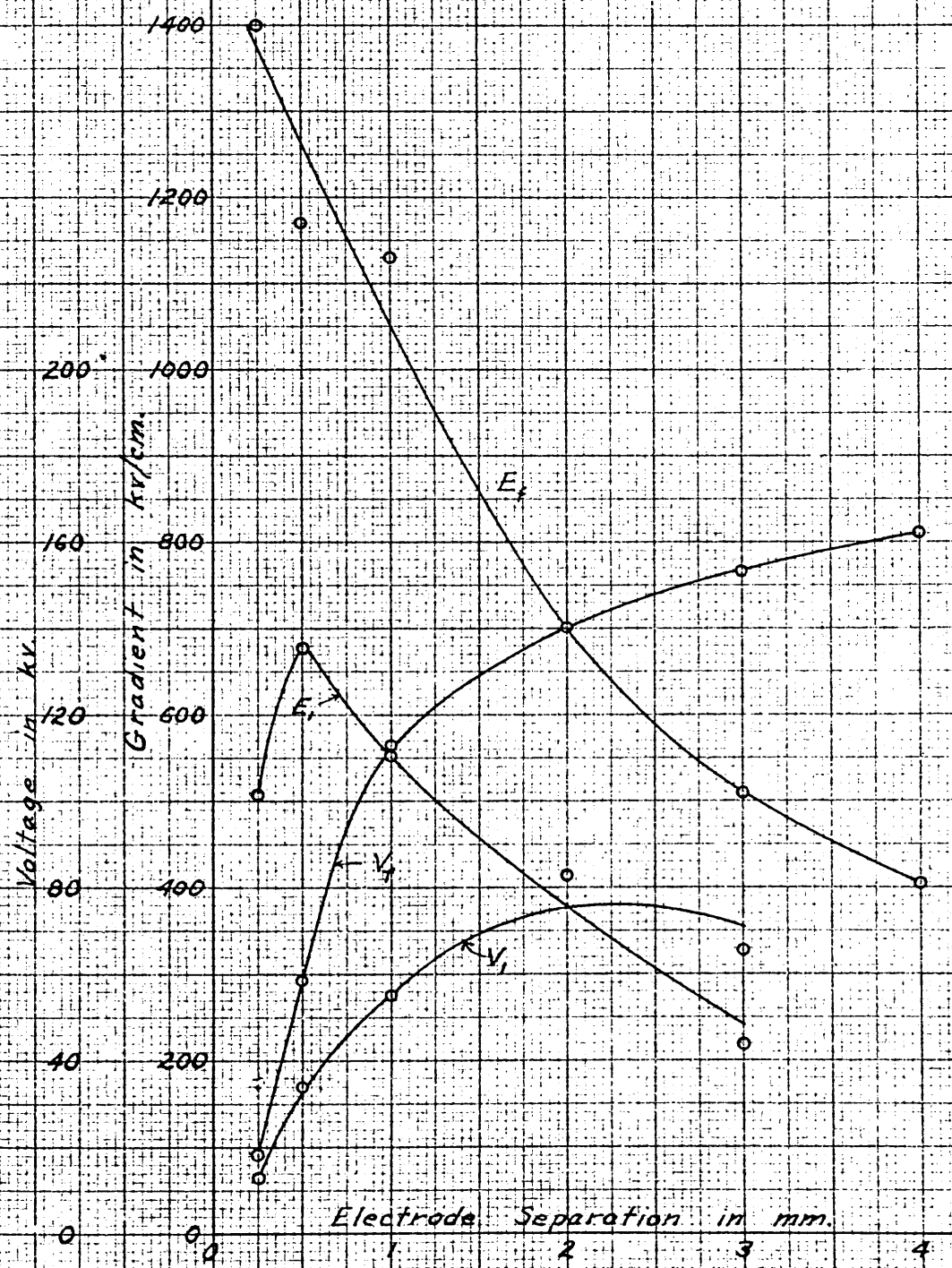

Fig. 31. Voltage and gradient vs electrode separation

Subscript 1, first breakdown

Subscript f, after improvement due to sparking

Cathode, nickel, 31-mil plate, polished and buffed

Anode, nickel, 1-in. rod with hemispherical end

Electrodes conditioned with hydrogen discharge

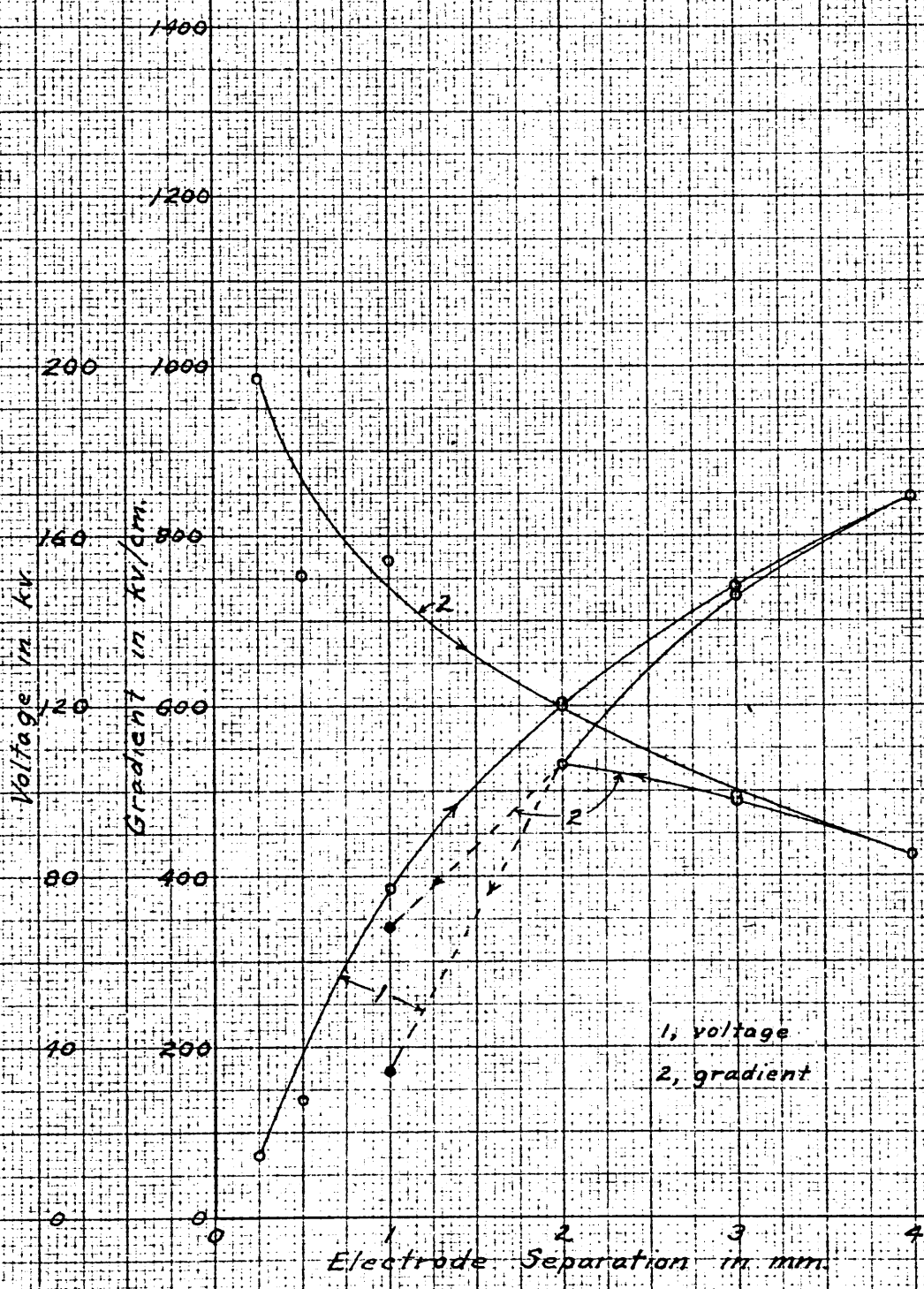

Fig. 32. Voltage and gradient after initial sparking versus electrode separation
 Cathode, molybdenum, 30-mil plate, unpolished
 Anode, 1-in. steel sphere
 Electrodes not conditioned

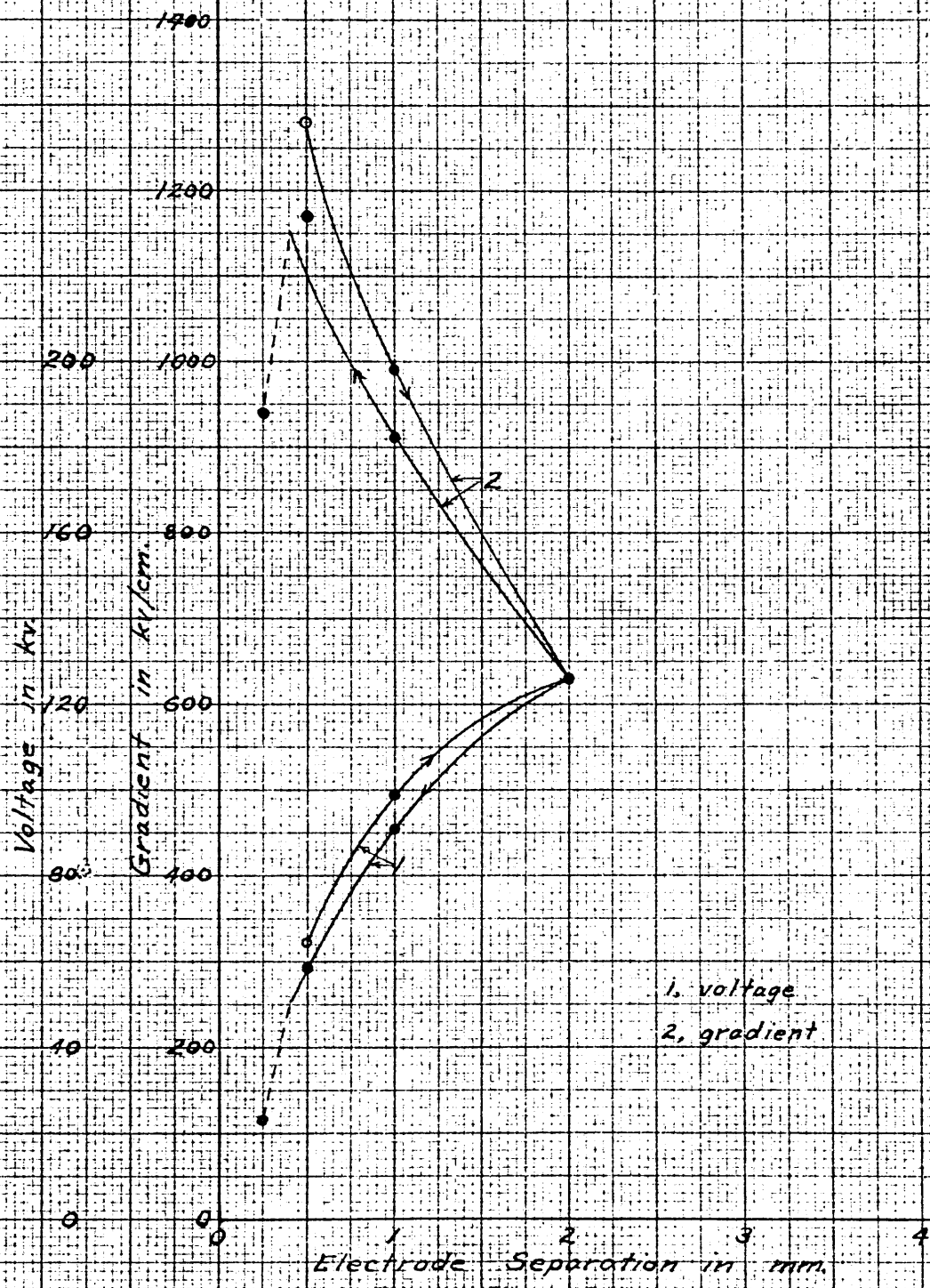

Fig. 35. Voltage and gradient after initial sparking versus electrode separation:

Cathode, molybdenum, 30-mil plate, unpolished
Anode, 1-in. steel sphere

Cathode conditioned with electron bombardment

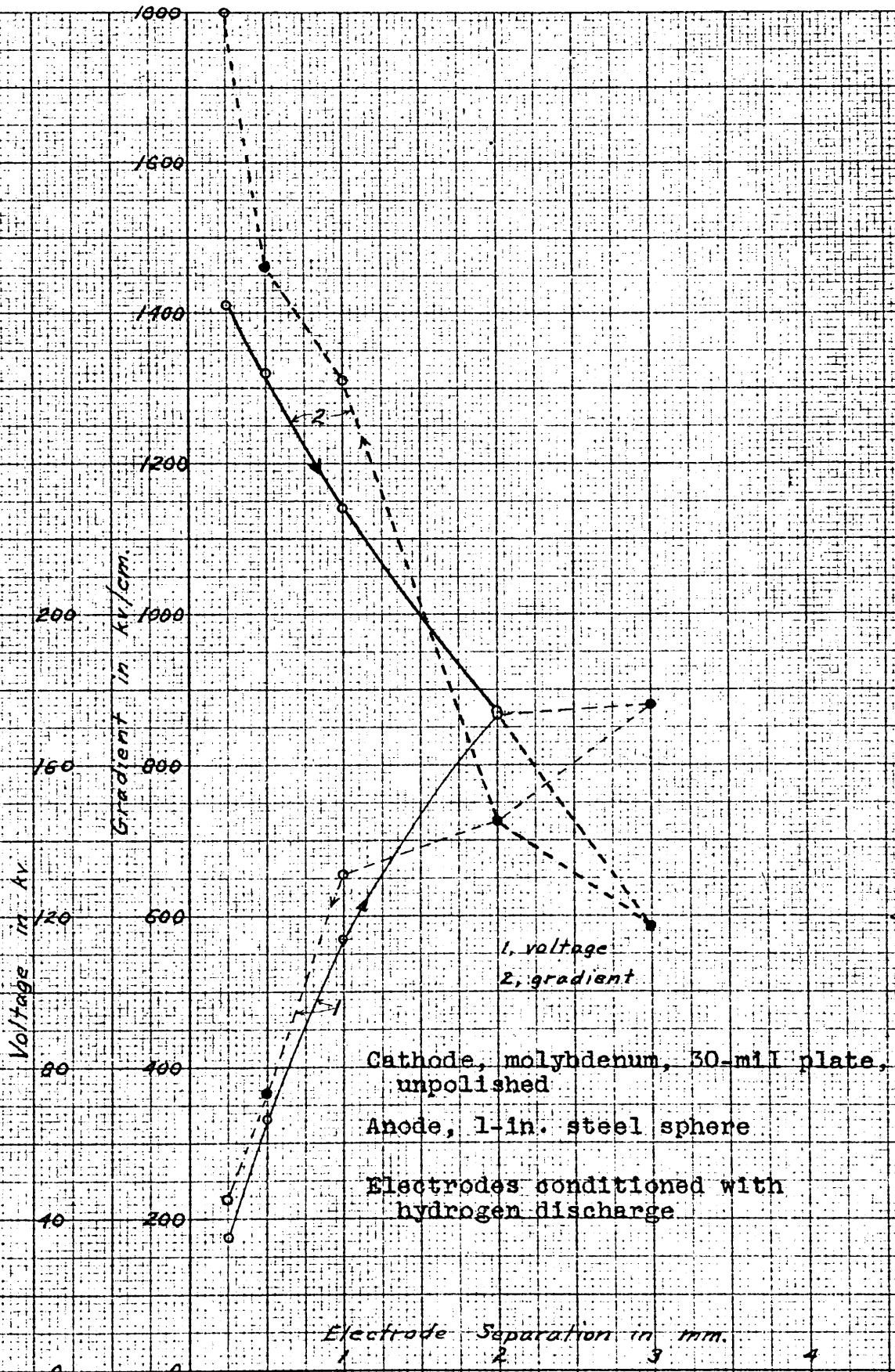

Fig. 34. Voltage and gradient after initial sparking versus electrode separation

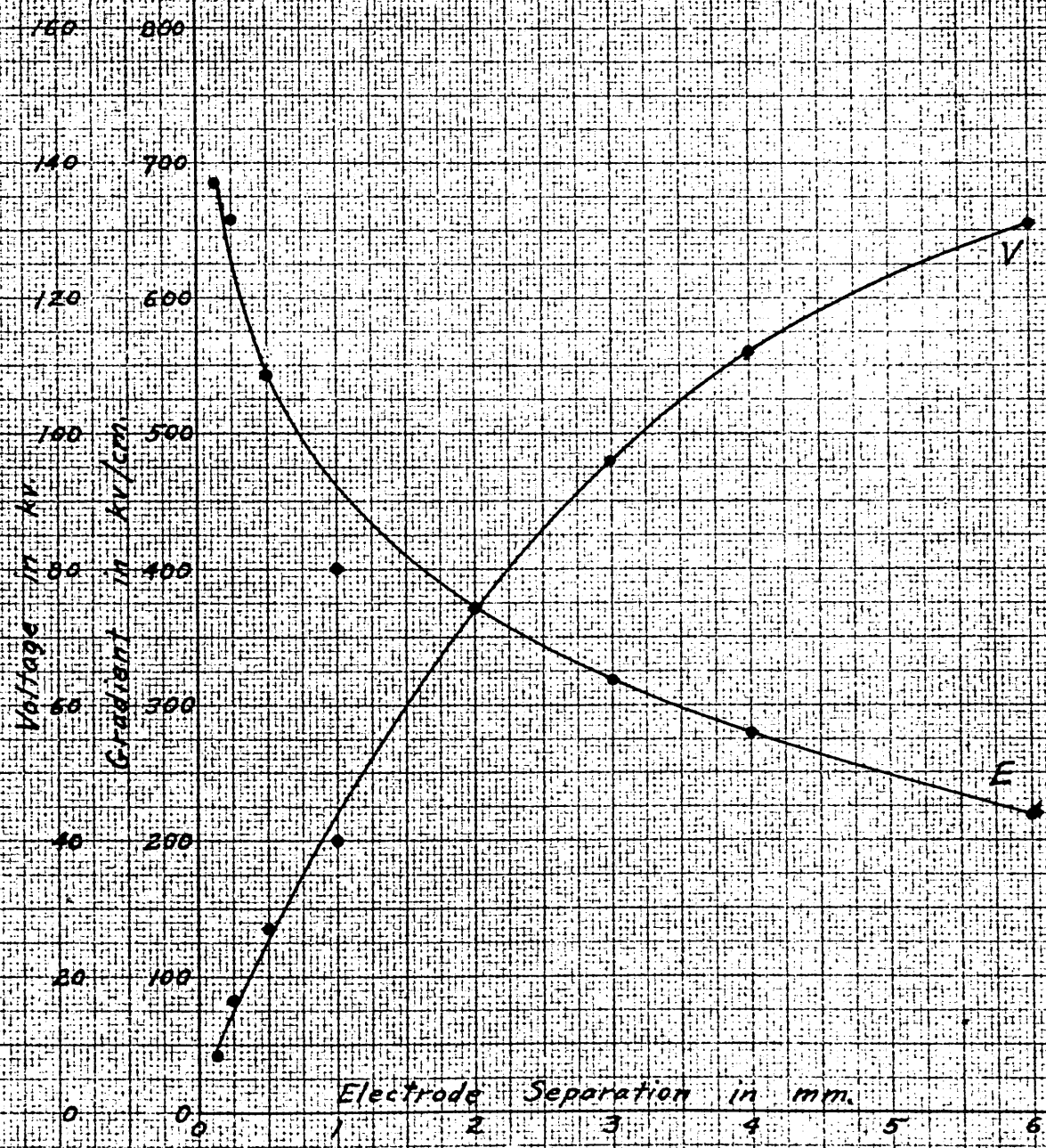

Fig. 35. Voltage and gradient vs electrode separation
 Monel electrodes
 Cathode, 40-mil plate, unpolished
 Anode, 1-in. sphere
 Electrodes not conditioned

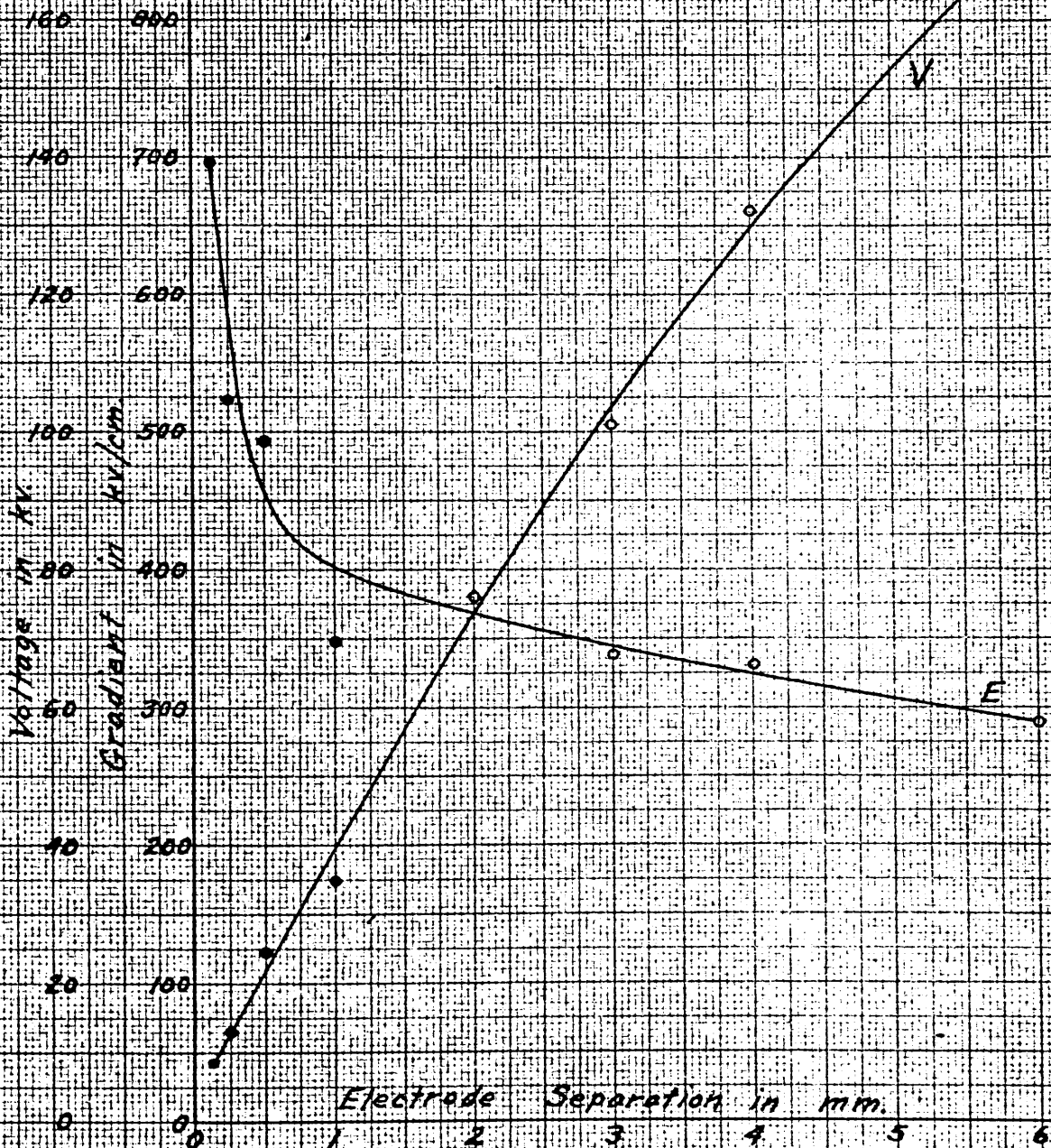

Fig. 36. Voltage and gradient vs electrode separation

Monel electrodes

Cathode, 40-mil plate, unpolished

Anode, 1-in. sphere

Cathode conditioned with electron bombardment

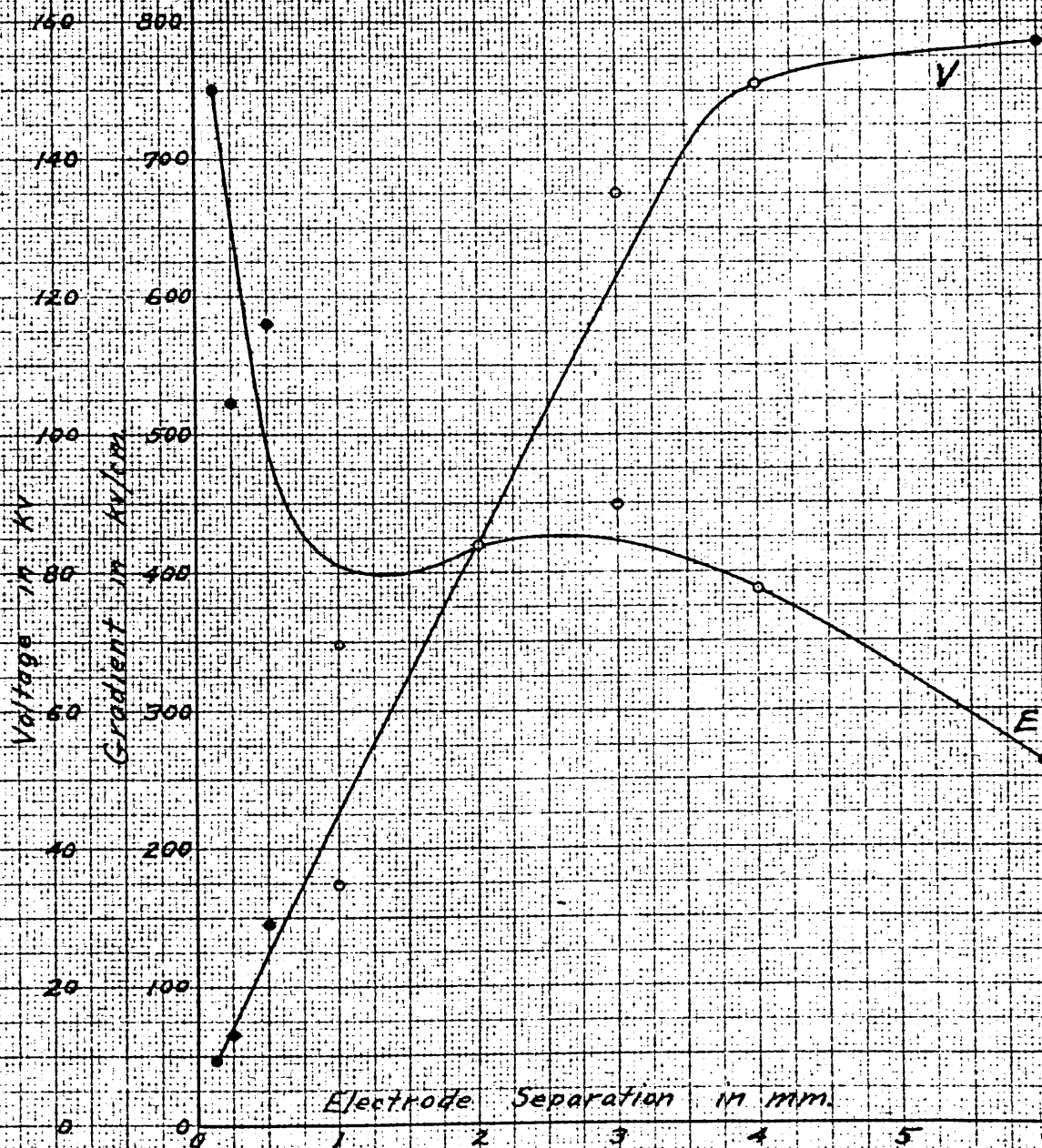

Fig. 37. Voltage and gradient vs electrode separation

Monel electrodes

Cathode, 40-mil plate, unpolished

Anode, 1-in. sphere

Electrodes conditioned with hydrogen discharge

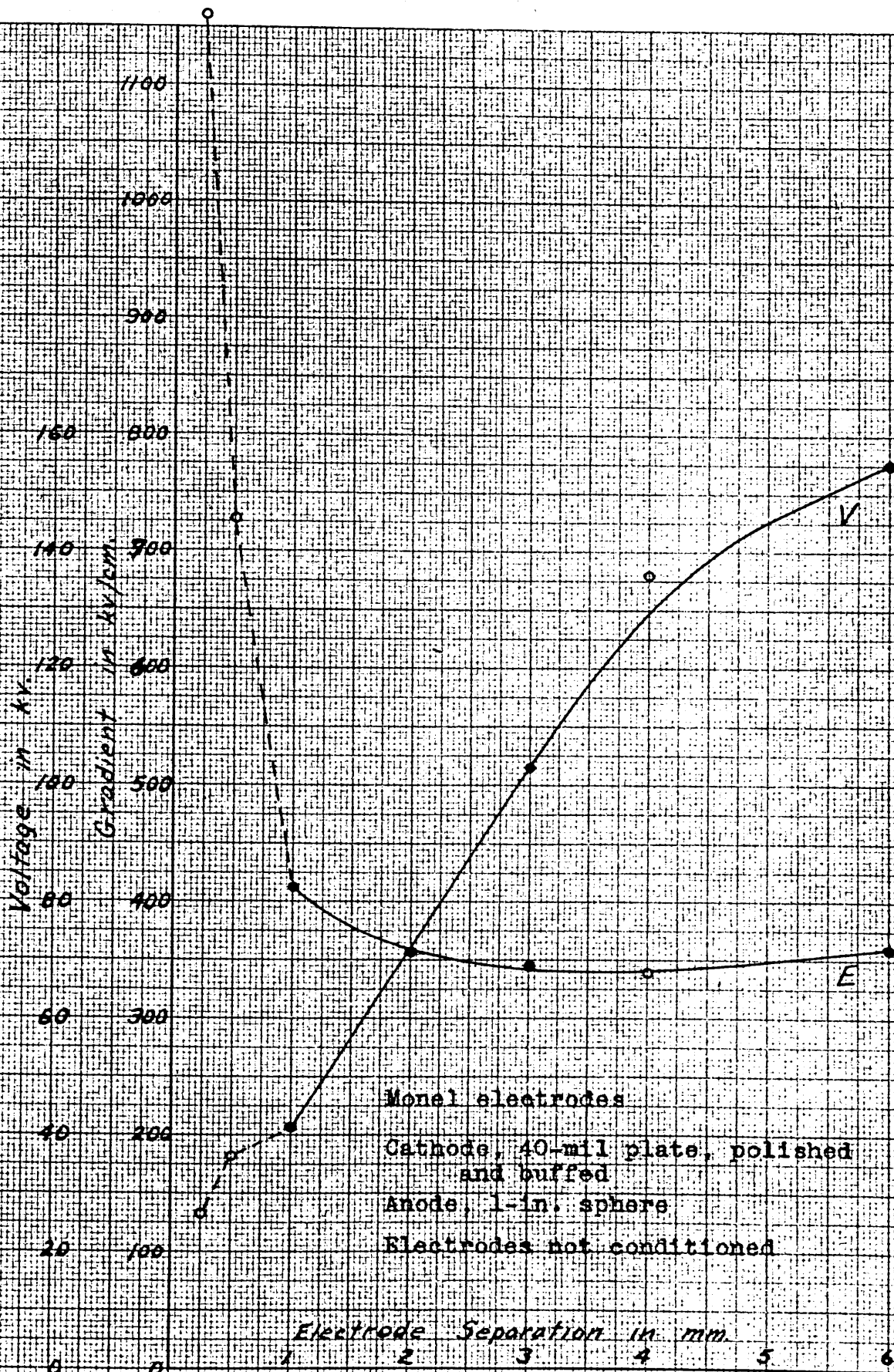

Fig. 3B. Voltage and gradient vs. electrode separation

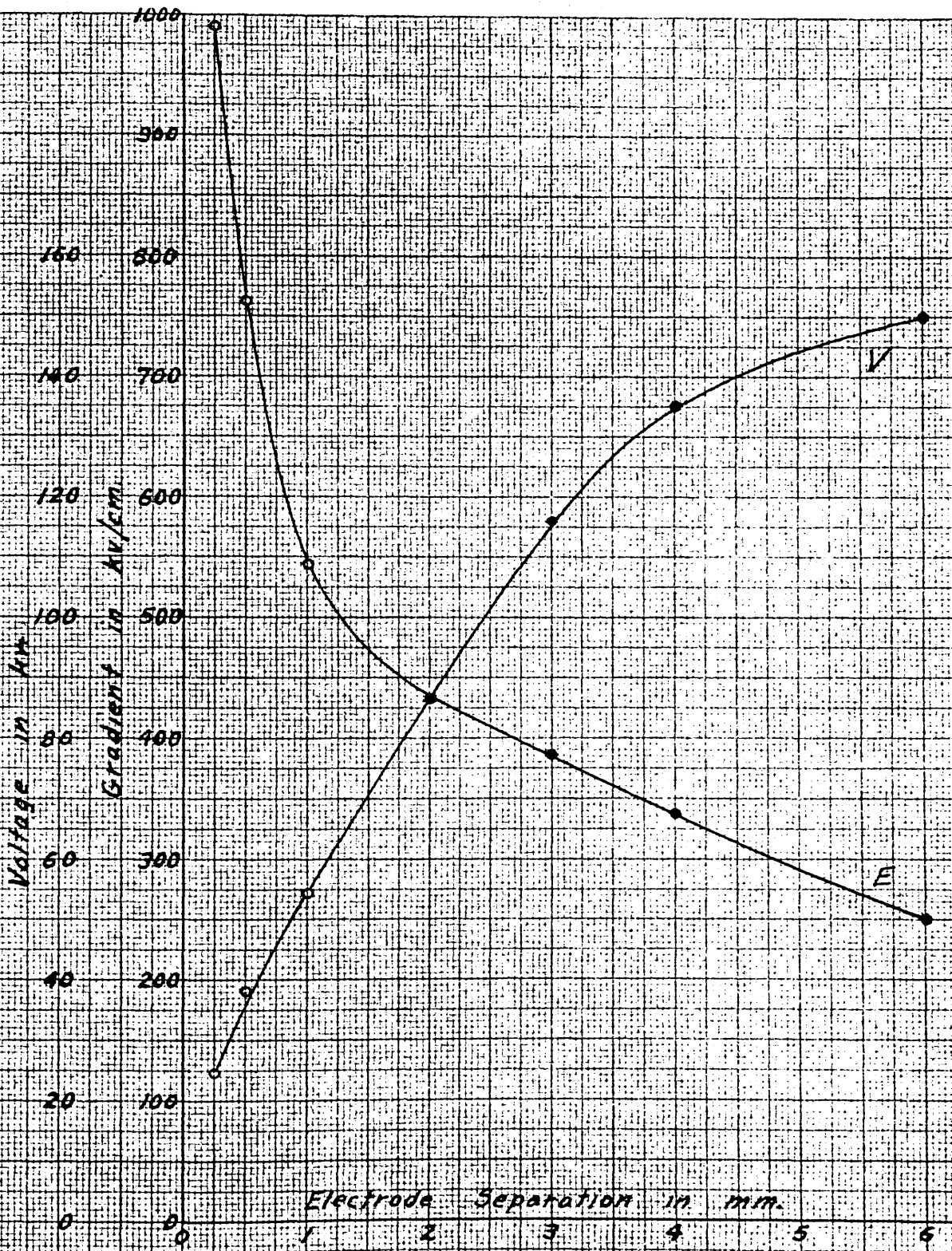

Fig. 39. Voltage and gradient vs electrode separation

Monel electrodes

Cathode, 40-mil plate, polished and buffed

Anode, 1-in. sphere

Cathode conditioned with electron bombardment

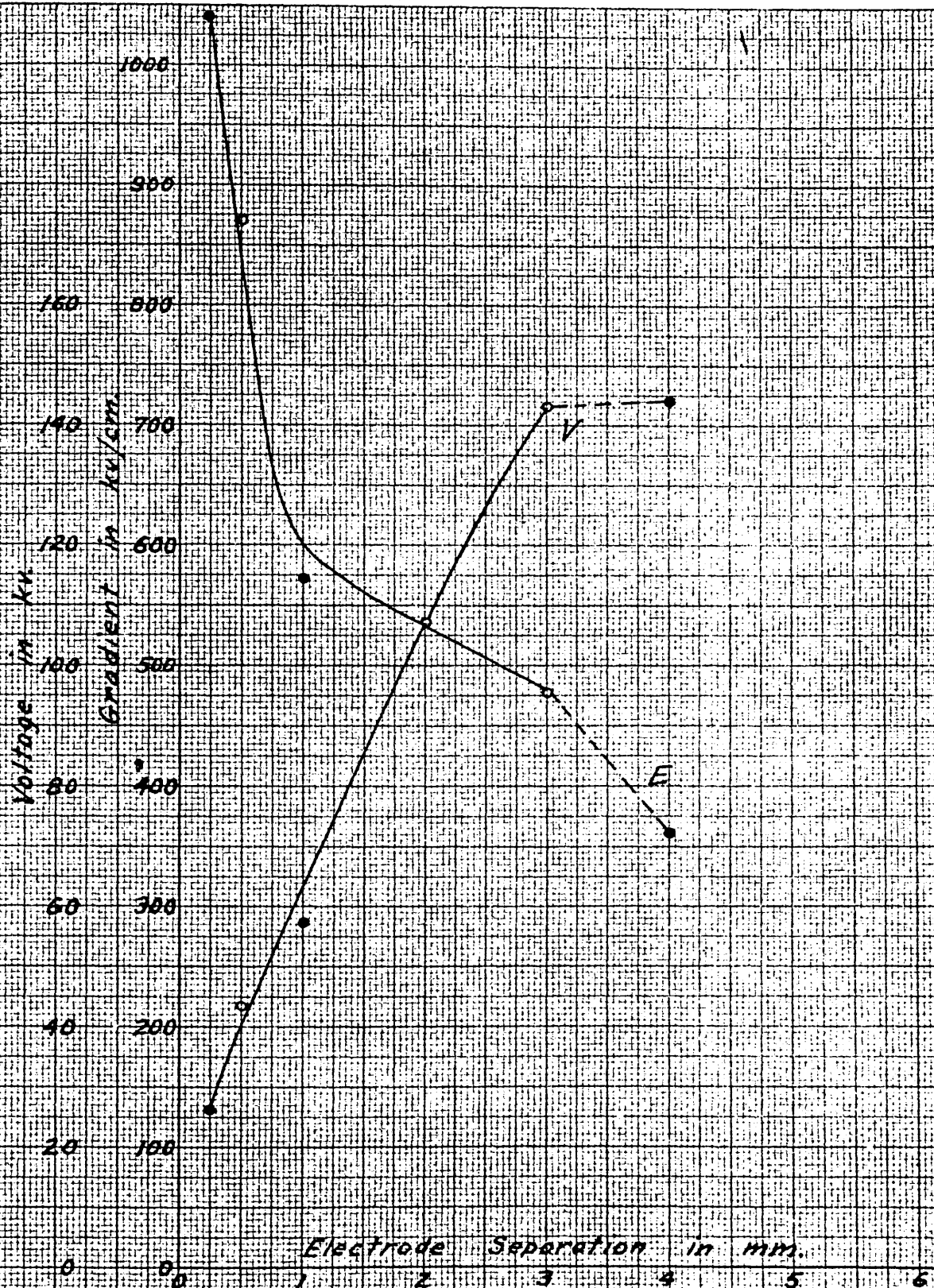

Fig. 40. Voltage and gradient vs electrode separation

Monel electrodes

Cathode, 40-mil plate, polished and buffed
 Anode, 1-in. sphere

Electrodes conditioned with hydrogen discharge

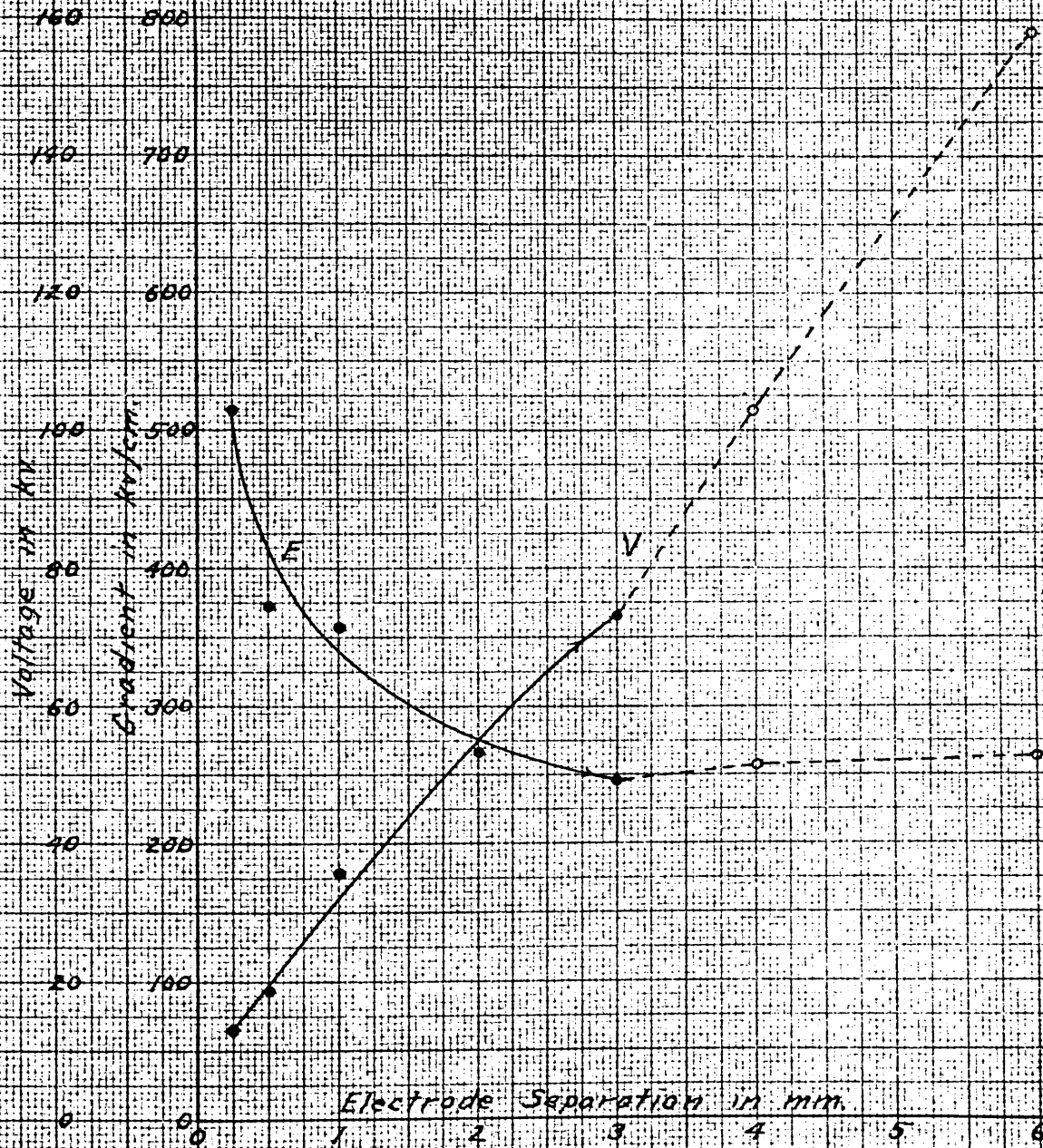

Fig. 41. Voltage and gradient vs electrode separation

Cathode, 62-mil plate, copper
Anode, 1-in. ball, copper

Electrodes not conditioned

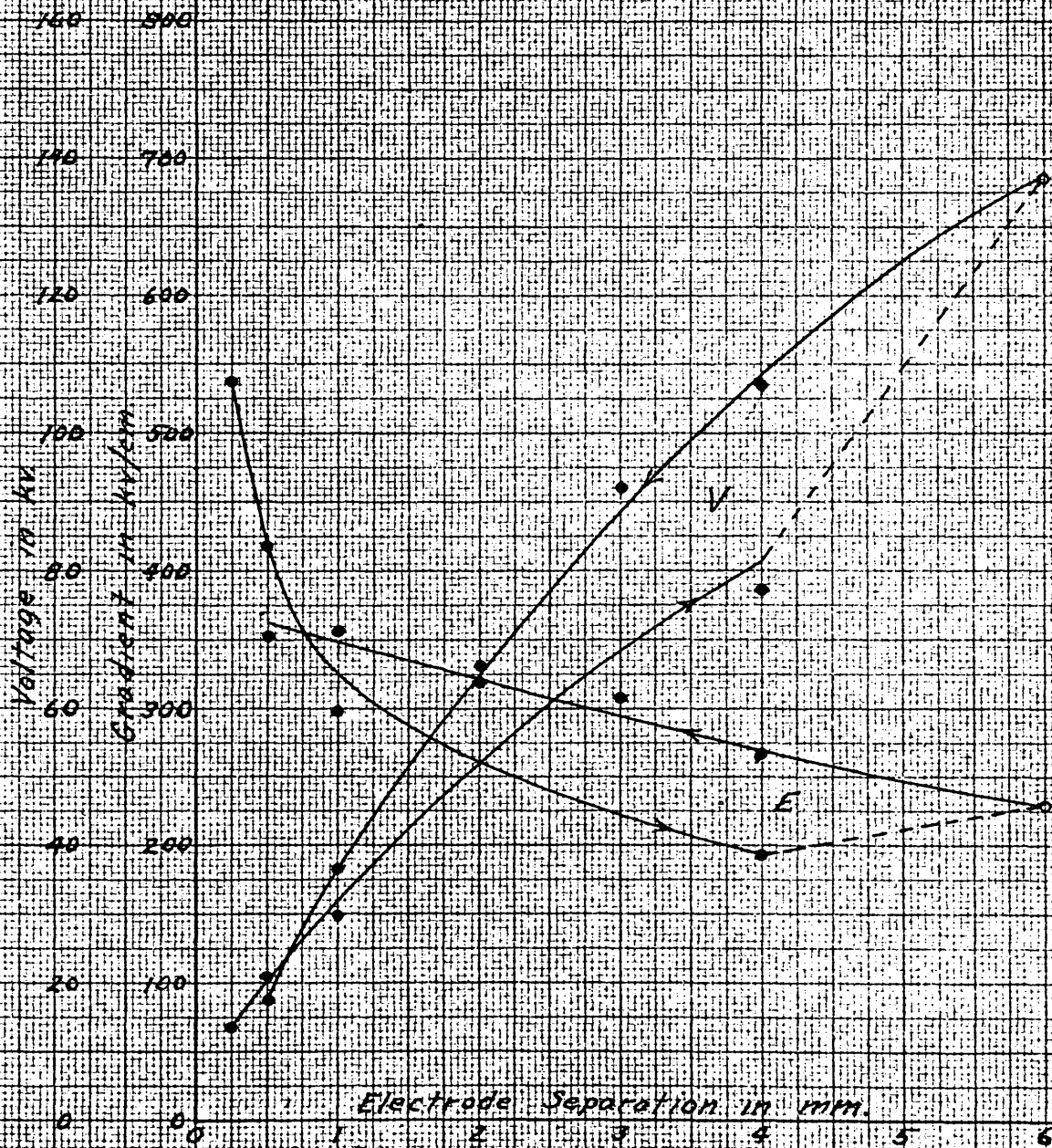

Fig. 42. Voltage and gradient vs electrode separation

Cathode, copper, 62-mil plate

Anode, copper, 1-in. ball

Cathode conditioned with electron bombardment

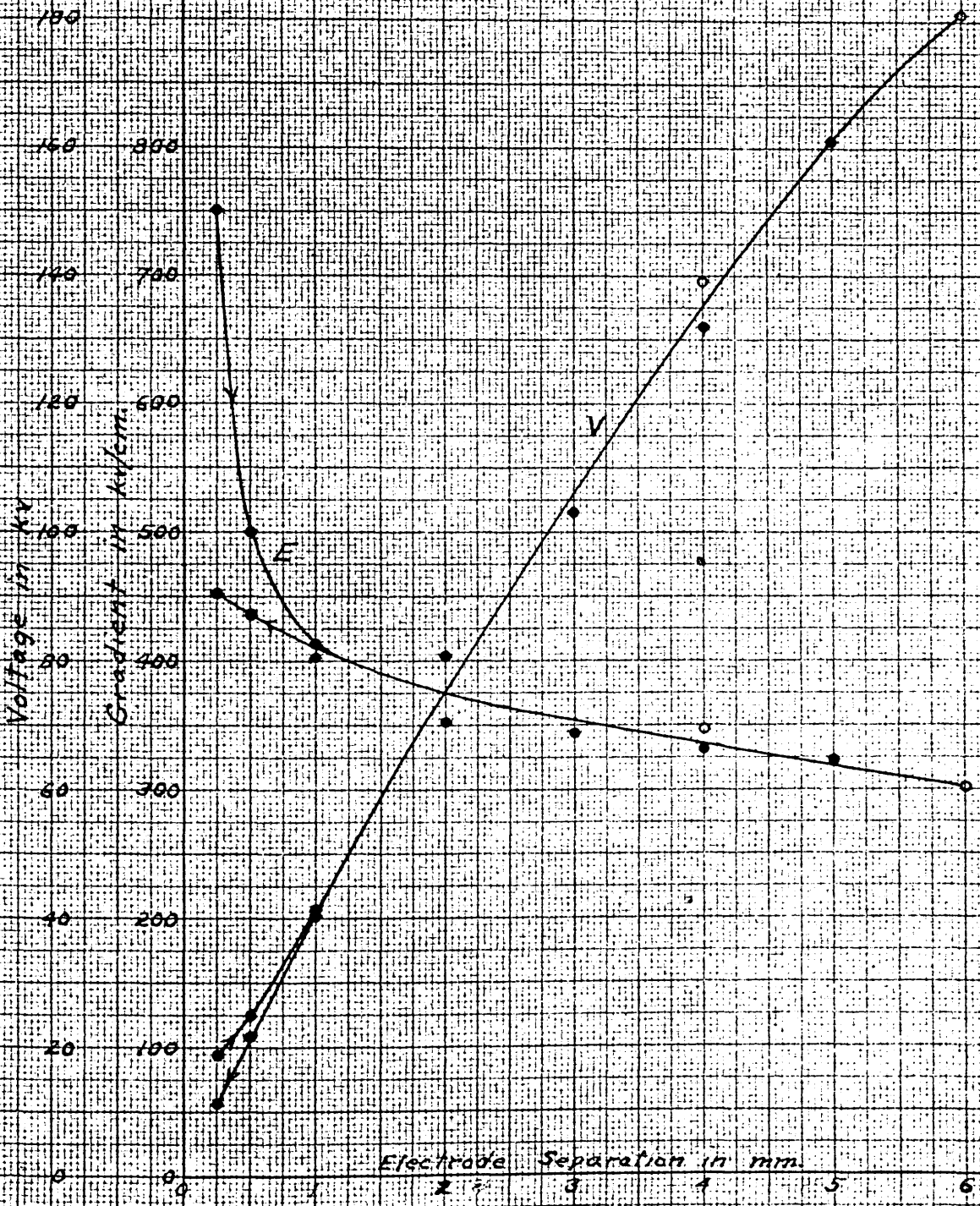

Fig. 43. Voltage and gradient vs electrode separation
 Cathode, copper, 82-mil plate
 Anode, copper, 1-in. ball
 Electrodes conditioned with hydrogen discharge

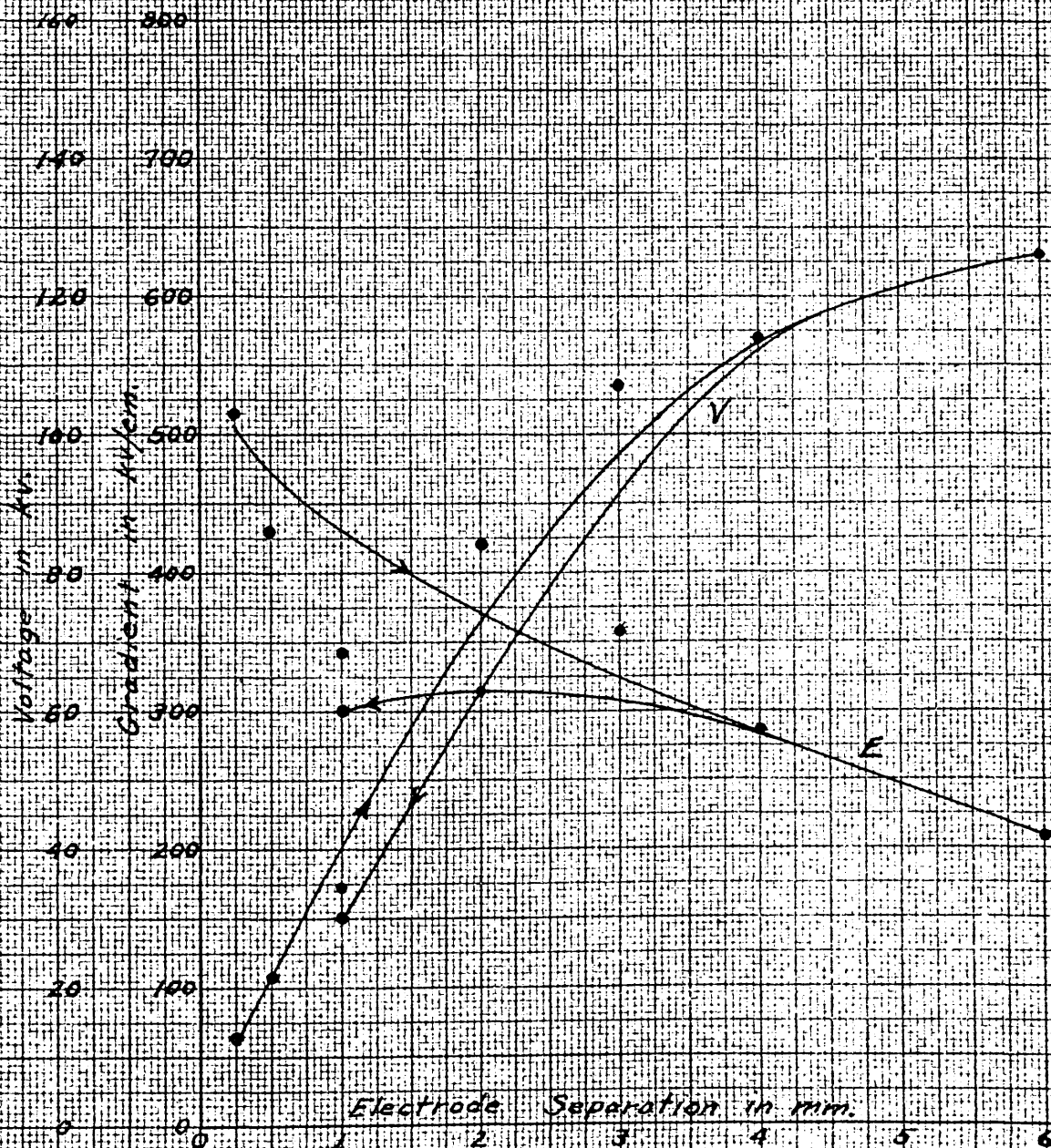

Fig. 44. Voltage and gradient vs electrode separation

Cathode, copper, 62-mil plate, polished and buffed
Anode, copper, 1-in. ball

Electrodes not conditioned

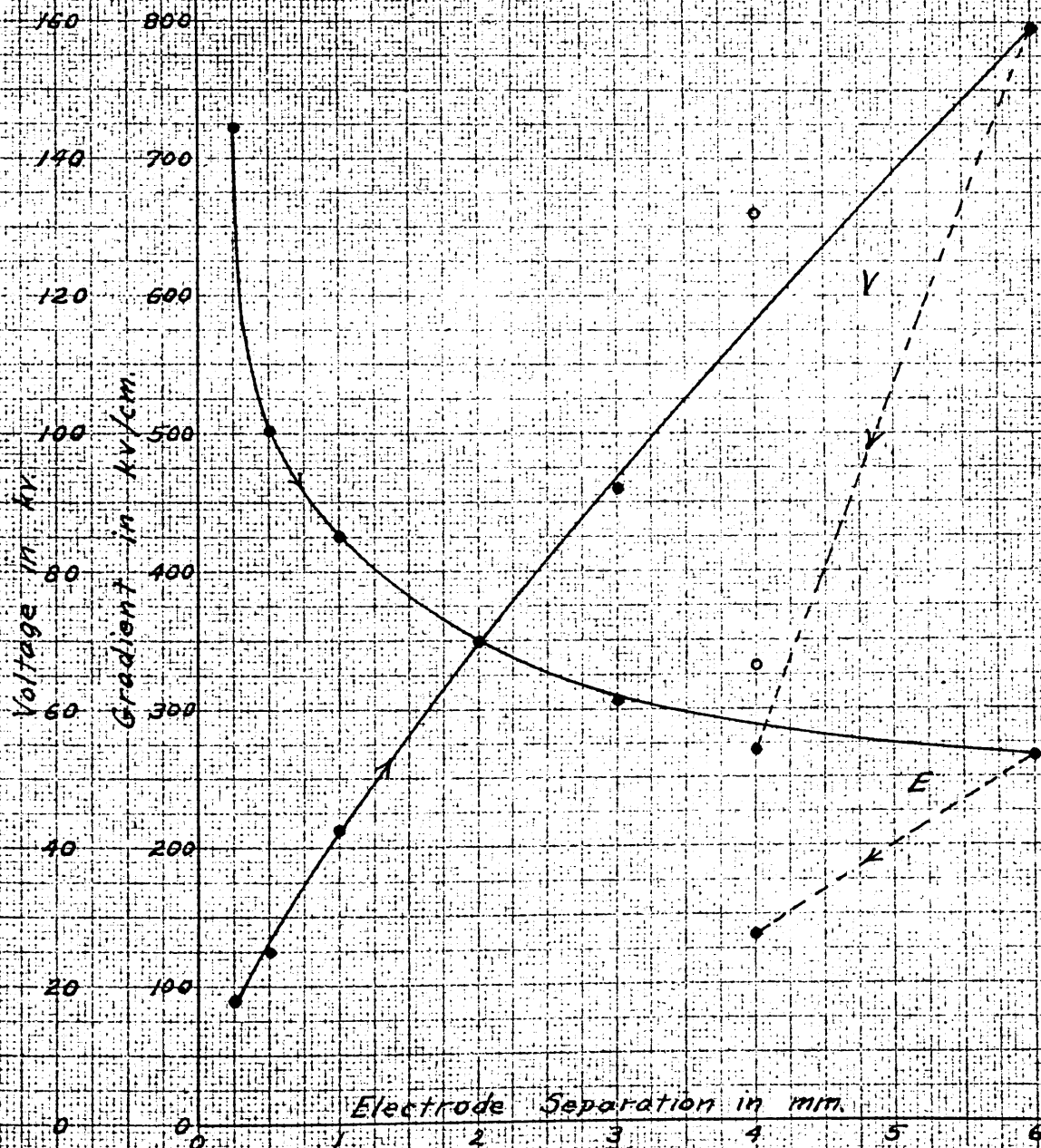

Fig. 45. Voltage and gradient vs electrode separation

Cathode, copper, 62-mil plate, polished and buffed
 Anode, copper, 1-in. ball

Electrodes conditioned with hydrogen discharge

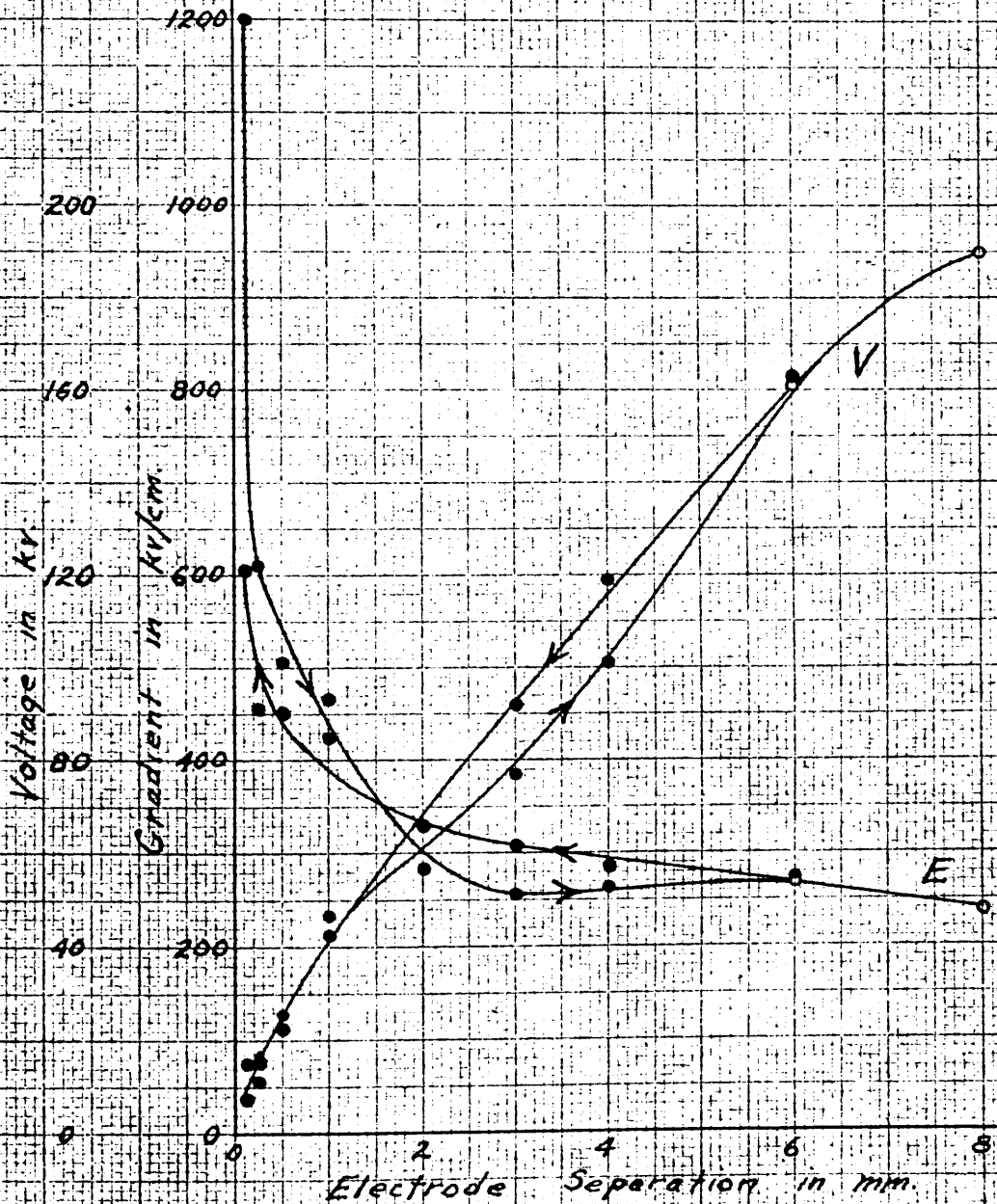

Fig. 46. Voltage and gradient vs electrode separation

Plate maintained negative throughout

Aluminum electrodes

Cathode, 62-mil plate, unpolished
Anode, 1-in. sphere

Electrodes not conditioned

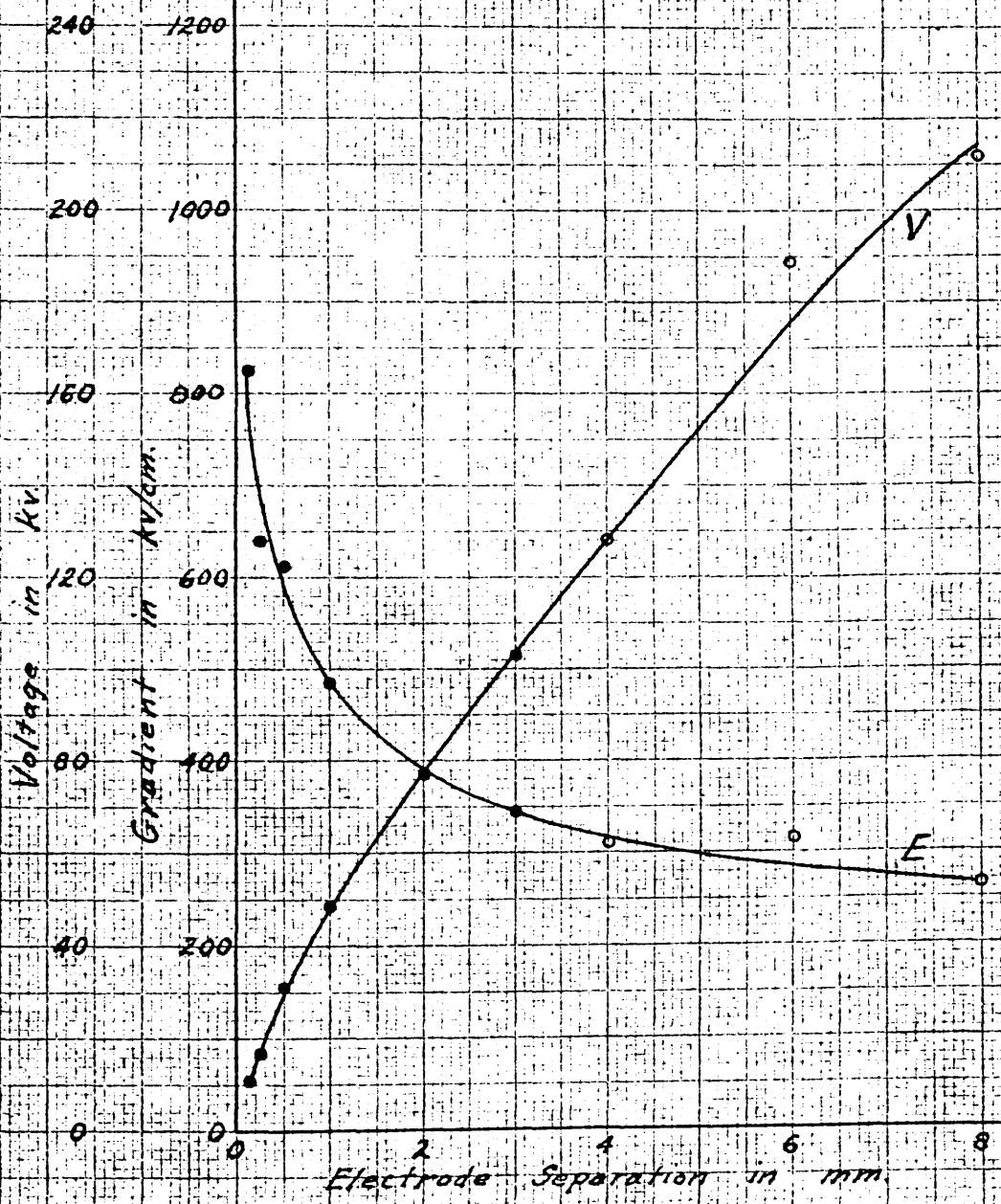

Fig. 47. Voltage and gradient vs electrode separation

Aluminum electrodes

Cathode, 62-mil plate, unpolished
 Anode, 1-in. sphere

Electrodes not conditioned

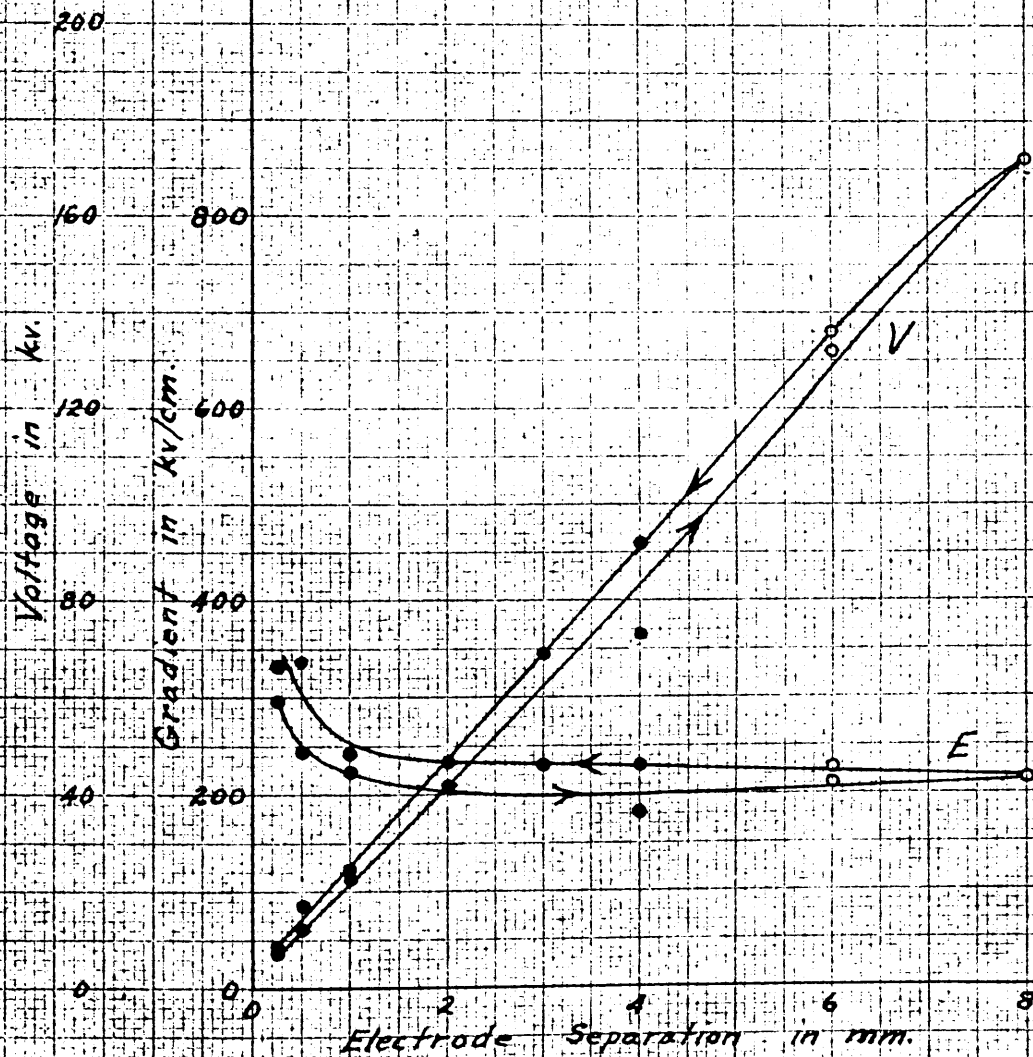

Fig. 48. Voltage and gradient vs electrode separation

Aluminum electrodes

Cathode, 62-mil plate, polished and buffed

Anode, 1-in. sphere

Electrodes not conditioned

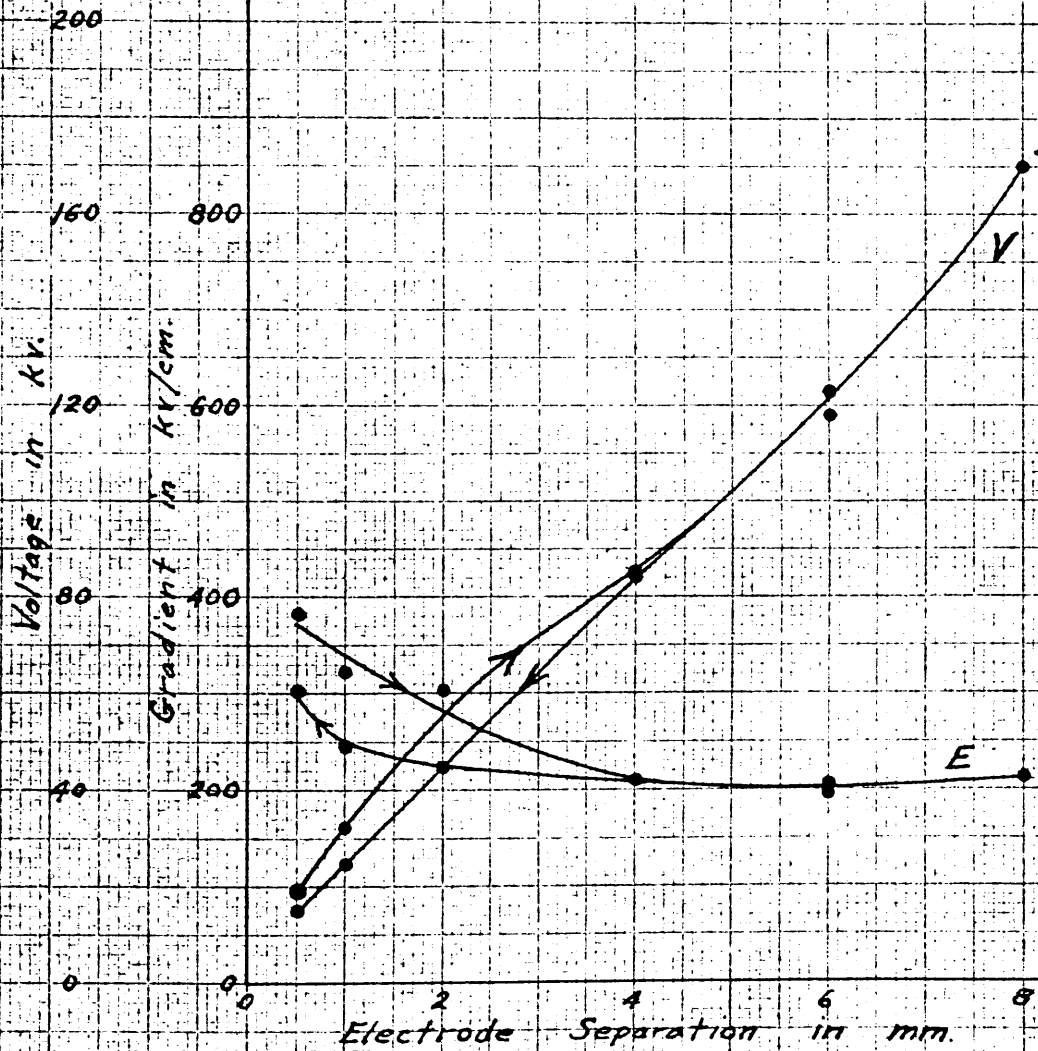

Fig. 49. Voltage and gradient vs electrode separation

Aluminum electrodes

Cathode, 62-mil plate, polished and buffed

Anode, 1-in. sphere

Electrodes conditioned with light hydrogen discharge

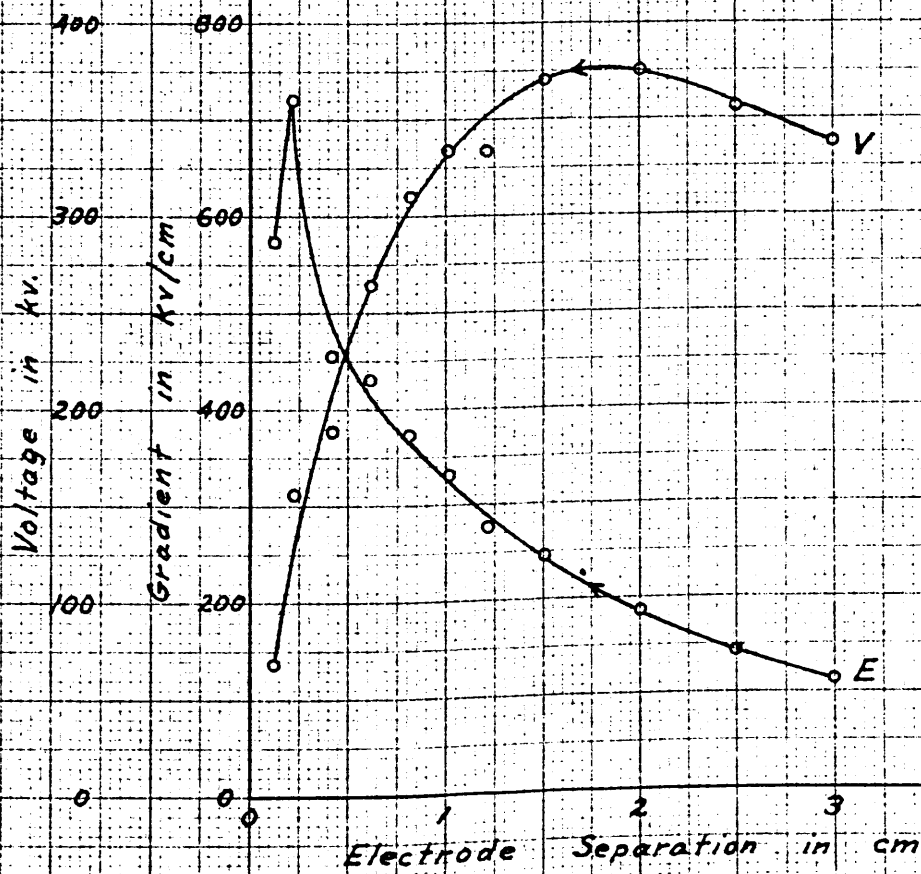

Fig. 50. Voltage and gradient after initial sparking versus electrode separation

Steel electrodes: 2-in. disk and 1-in. sphere

Electrodes conditioned with hydrogen discharge

Vapor-screening compartment not in place

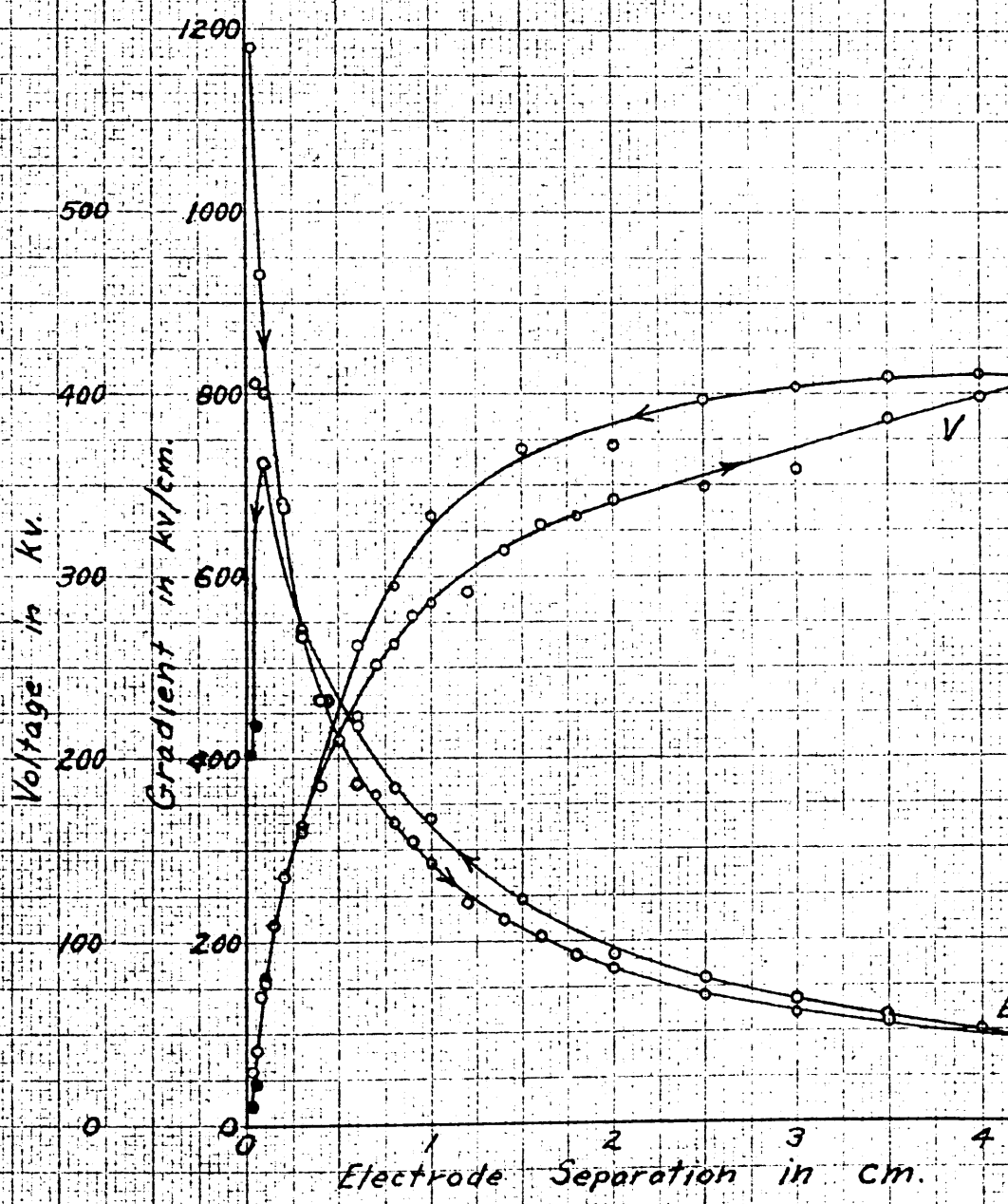

Fig. 51. Voltage and gradient after initial sparking versus electrode separation

Flat electrode negative throughout

Steel electrodes: 2-in. disk and 1-in. sphere

Electrodes not conditioned

Vapor-screening compartment in place

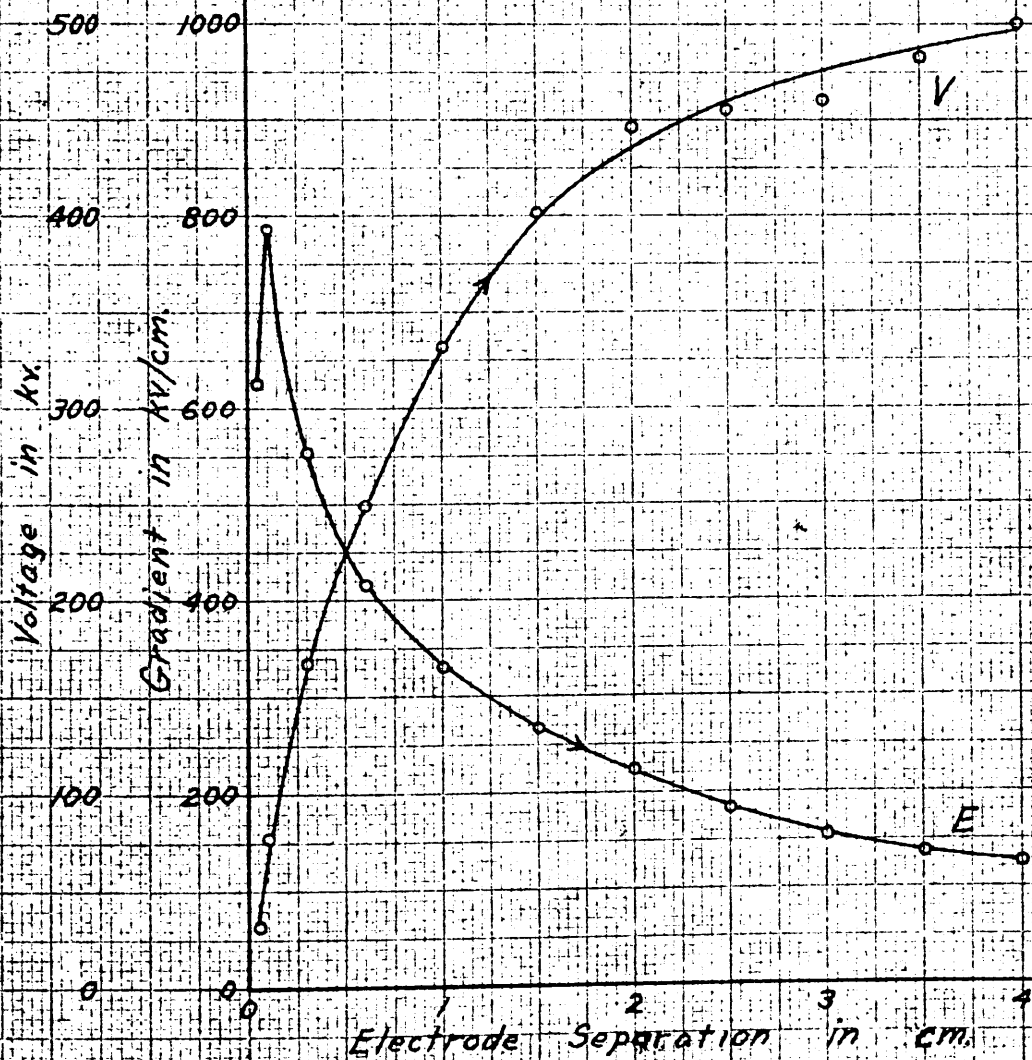

Fig. 52. Voltage and gradient after initial sparking versus electrode separation

Flat electrode negative throughout

Steel electrodes: 2-in. disk and 1-in. sphere

This is a continuation of the run of Fig. 51.

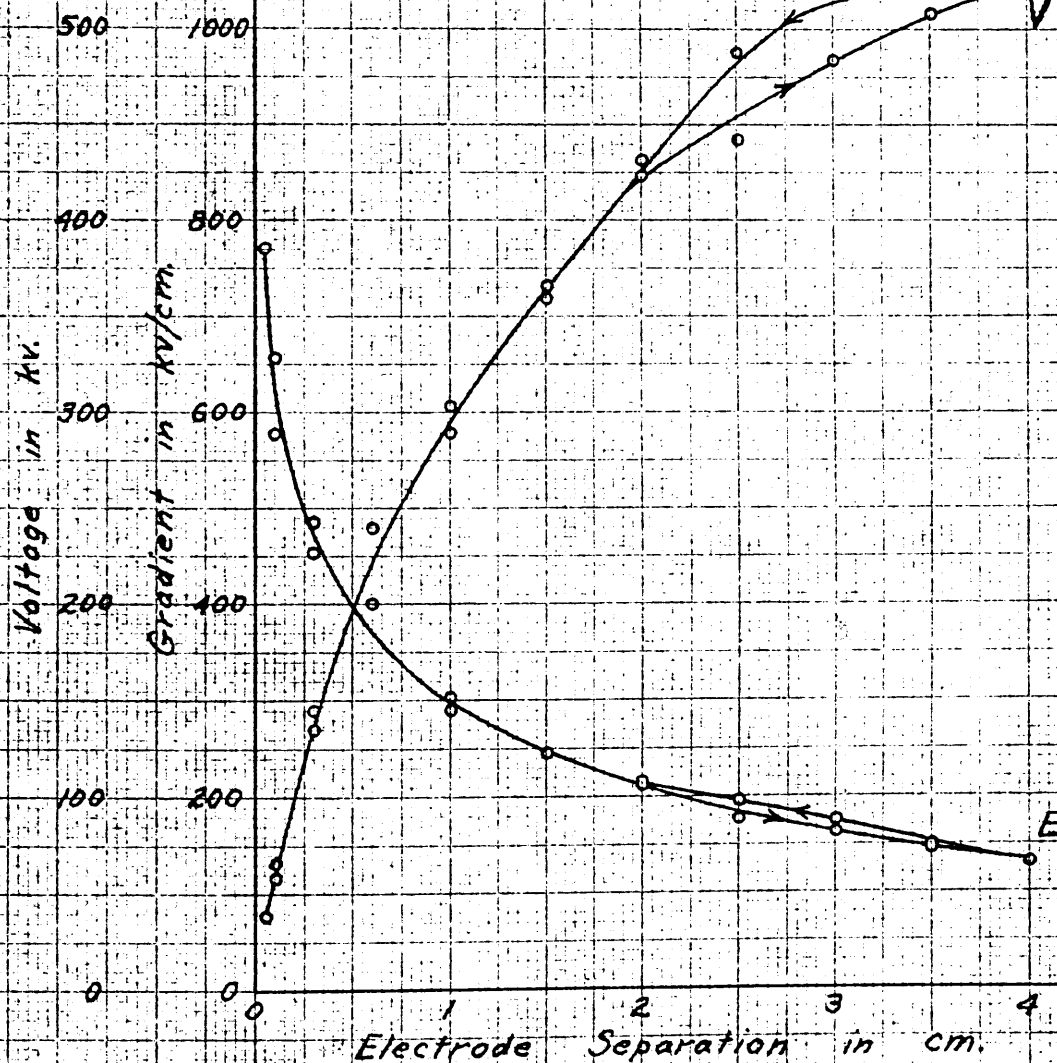

Fig. 53. Voltage and gradient vs electrode separation

Readings taken with flat electrode negative,
after sparking with each polarity

Steel electrodes: 2-in. disk and 1-in. sphere

This is one of a succession of runs on a single pair
of electrodes, beginning with the run plotted in Fig. 51.

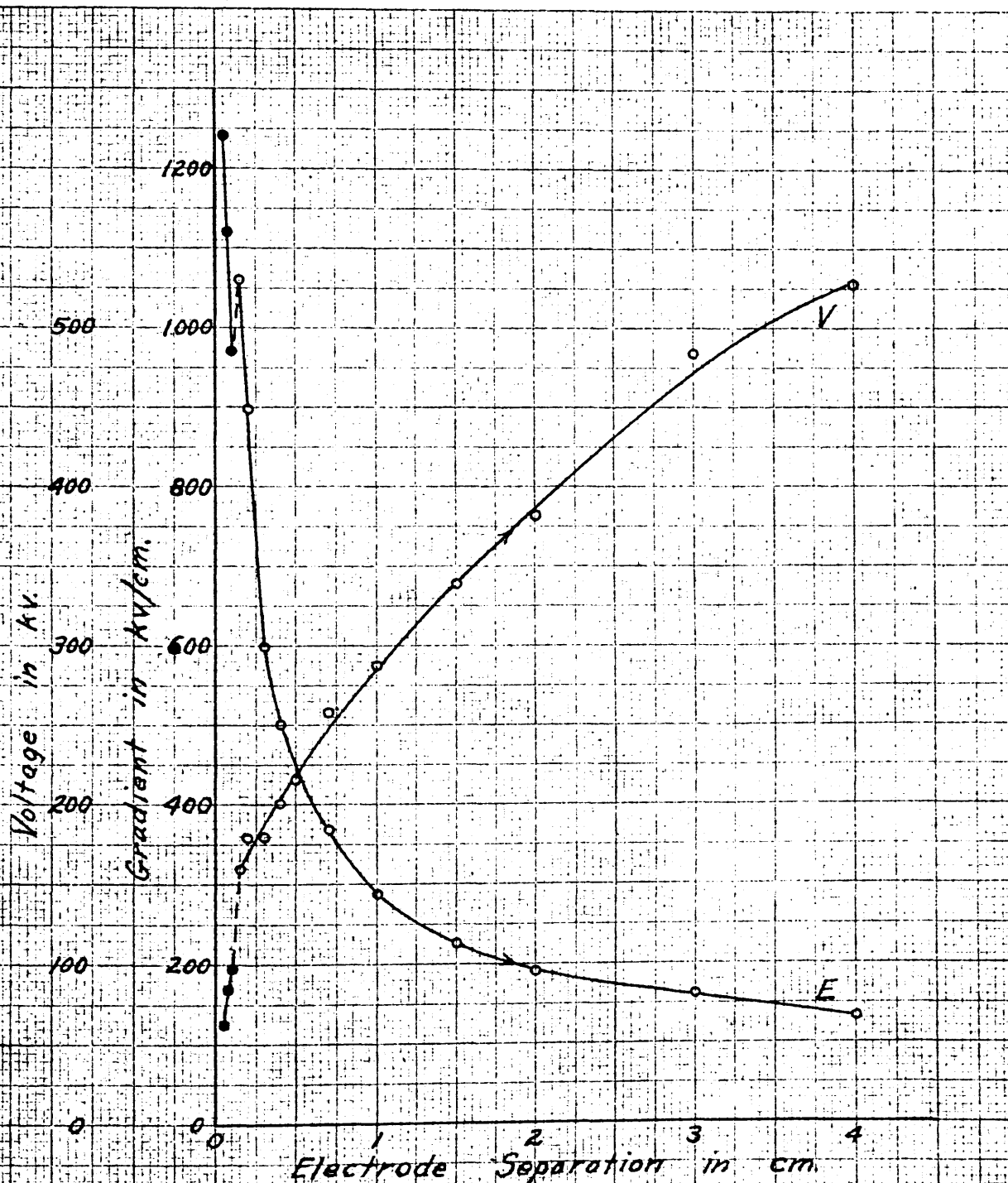

Fig. 54. Voltage and gradient vs electrode separation

Run preceded by a-c breakdown with 0.5-mm gap

Readings taken with flat electrode negative,
after sparking with each polarity

Steel electrodes: 2-in. disk and 1-in. sphere

This is one of a succession of runs on a single pair of electrodes, beginning with the run plotted in Fig. 51.

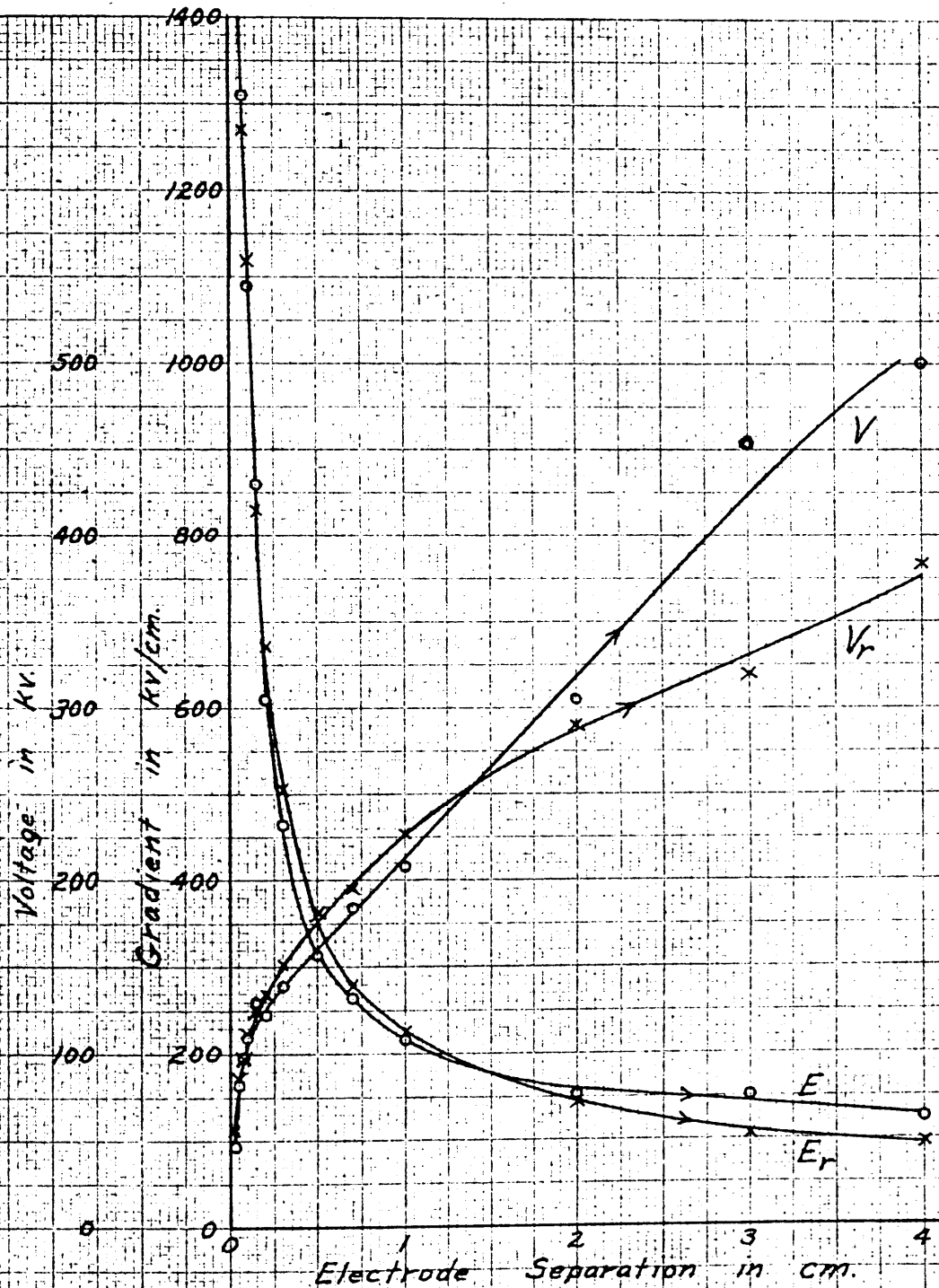

Fig. 55. Voltage and gradient after initial sparking versus electrode separation

Run preceded by a-c breakdown at points shown in Fig. 56

Small circles, flat electrode negative
 Crosses, spherical electrode negative

Steel electrodes: 2-in. disk and 1-in. sphere

This is one of a succession of runs on a single pair of electrodes, beginning with the run plotted in Fig. 51.

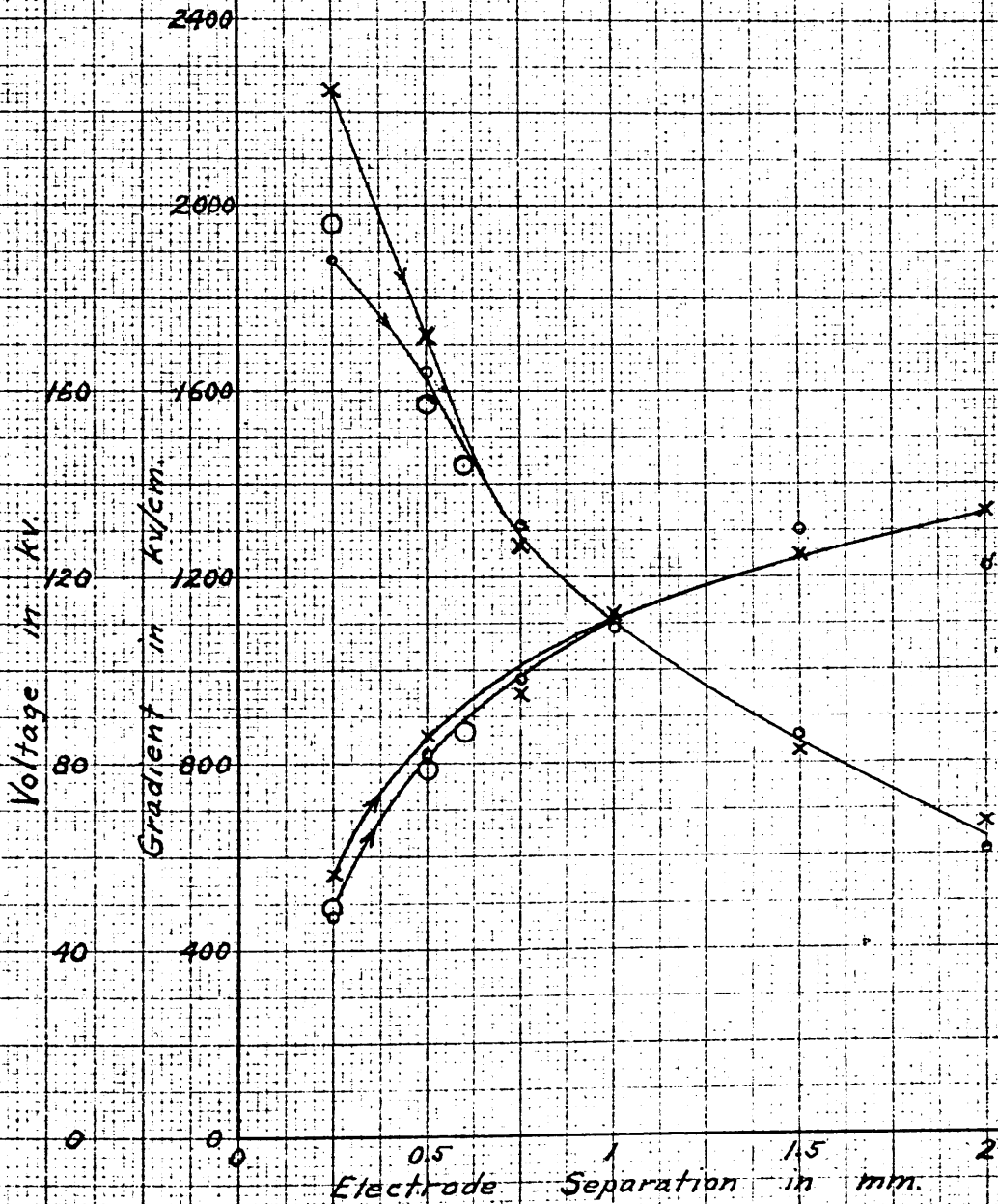

Fig. 56. Enlargement of short-gap portion of curves of Fig. 55

Large circles, a-c points
 Small circles, flat electrode negative
 Crosses, spherical electrode negative

Steel electrodes: 2-in. disk and 1-in. sphere

This is one of a succession of runs on a single pair of electrodes, beginning with the run plotted in Fig. 51.

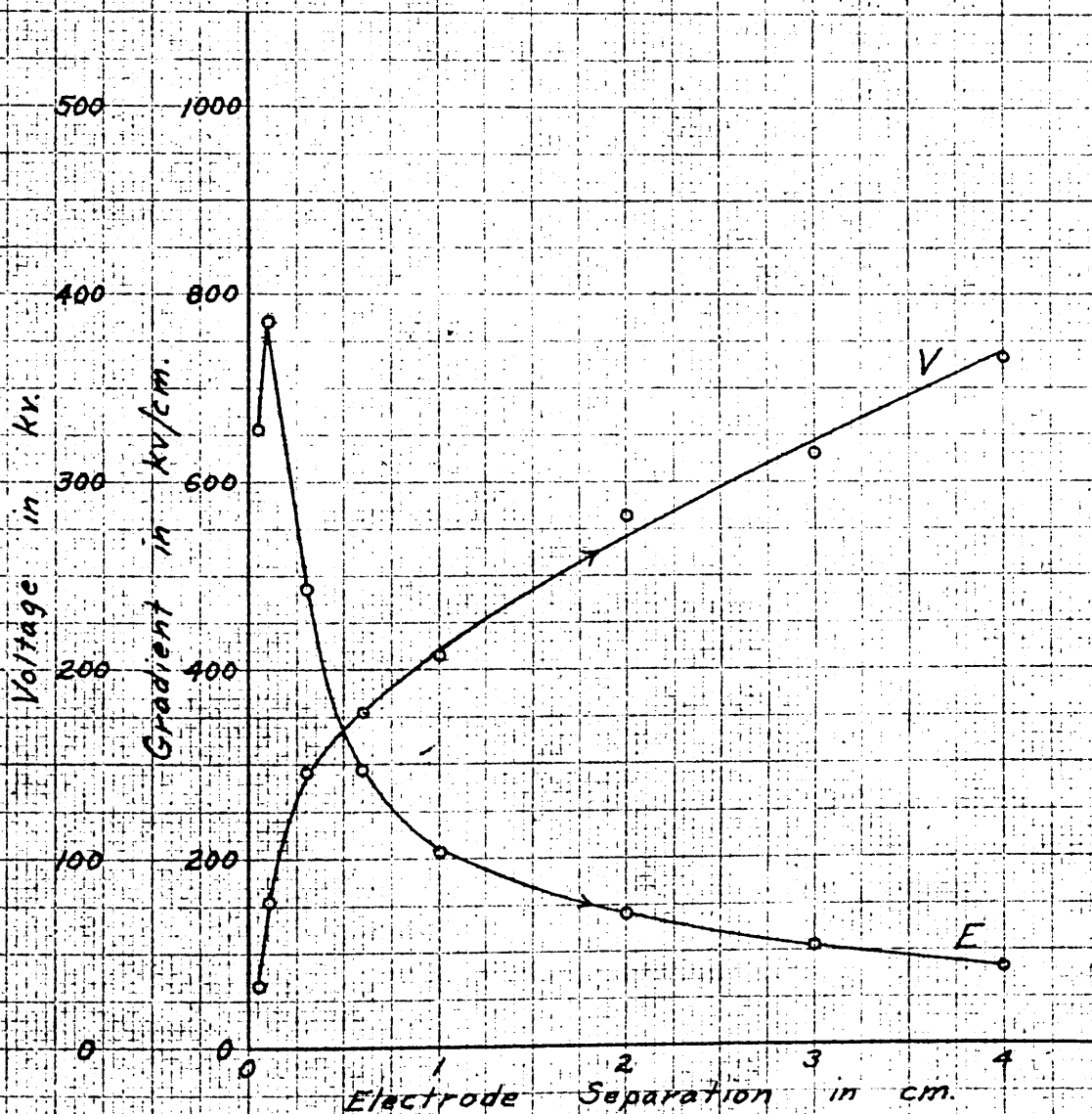

Fig. 57. Voltage and gradient vs electrode separation

Run preceded by hydrogen discharge between electrodes

Readings taken with flat electrode negative,
after sparking with each polarity

Steel electrodes: 2-in. disk and 1-in. sphere

This is one of a succession of runs on a single pair of electrodes, beginning with the run plotted in Fig. 51/

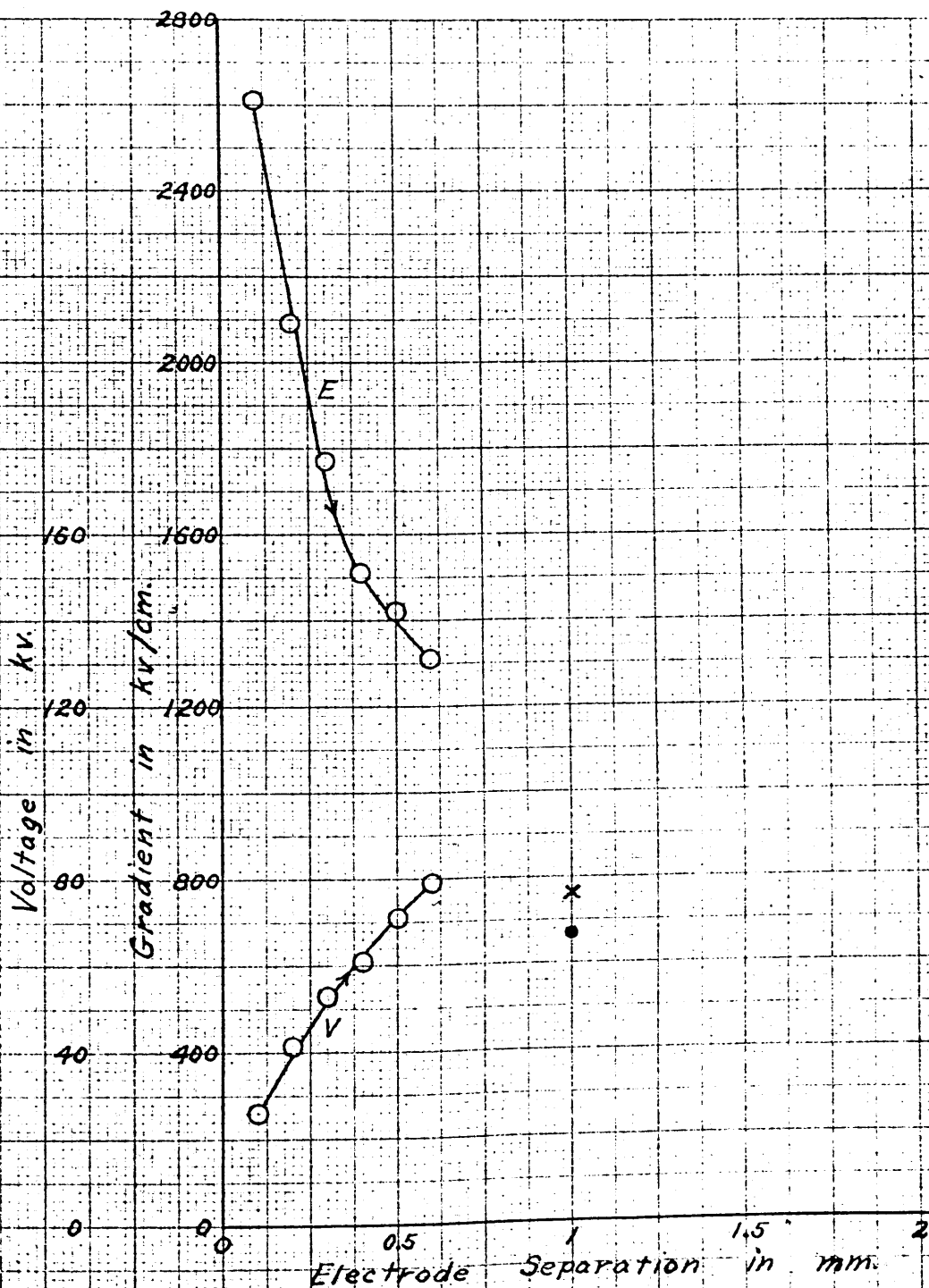

Fig. 58. Run with a-c power. Voltage and gradient after initial sparking versus electrode separation

Large circles, a-c points
 Small circle, flat electrode negative
 Cross, spherical electrode negative
 (D-c tests followed a-c run)

Steel electrodes: 2-in. disk and 1-in. sphere

This is the last of a succession of runs on a single pair of electrodes, beginning with the run plotted in Fig. 51.

(Continued from page 68)

Though the a-c and d-c power sources have widely different characteristics, the following comparison is made. The time constant of the resistance-capacitance circuit connected to the transformer was about 3×10^{-4} sec. Consequently, at rated crest voltage the transformer would bring the test gap from zero to 0.63×71 or 45 kv in the above time. To charge its capacitance to the same voltage, the d-c generator would require 2.2×10^{-2} sec. Thus the a-c breakdown would be followed by a much more rapid restoration of voltage than the d-c. Or, the a-c supply could (as a consequence of its greater power) produce a much more rapid succession of sparks. The other point of contrast between the a-c and d-c tests is that of polarity. As has been stated on page 57, frequent reversals of generator polarity were found to increase the breakdown voltage of a gap. In this manner, therefore, the a-c tests seem to possess an inherent advantage in conditioning electrodes.

At the end of this series when the electrodes were inspected, a third point of contrast between the a-c and d-c tests was found. A flat spot had been produced on the 1-in. sphere such that its diameter at the center of the spot had been reduced by 9 mils. Such an occurrence in comparable magnitude was never observed in any case of purely d-c tests.

For the next experiment after that of Fig. 53, the gap was subjected to a-c breakdown with a spacing of 0.5 mm.

Crest values of voltage and gradient for this were at first 69.3 kv and 1380 kv per cm, and improved with sparking to 80.6 kv and 1610 kv per cm. D-c measurements taken after this test are plotted in Fig. 54, page 114. Compared to the preceding d-c curve, this has higher values up to 0.8 cm, then falls below until the curves come together at 4 cm. Evidently the a-c breakdown had improved the short gaps, but the longer gaps, excepting the very longest, were made worse.

The results of a second a-c and subsequent d-c test are shown in Figs. 55 and 56, pages 115 and 116. The latter is an enlargement of the curves up to a 2-mm spacing; and also shows with large circles the crest values of the a-c measurements, after improvement due to sparking. D-c measurements with the usual polarity, plate as cathode, are indicated with the usual small circles. Measurements with the opposite polarity are indicated with crosses. As was the case in Fig. 15, page 75, measurements with the sphere as cathode were higher than those of the usual polarity, for gaps up to 1.4 cm. Except for the very shortest gap lengths, the curves of Fig. 55 are below those of the preceding test.

The electrodes were next subjected to a hydrogen discharge, and the results of a subsequent d-c test are plotted in Fig. 57, page 117. Except for a slight improvement between 0.25 and 0.9 cm, the results of this test are below those of Fig. 55. With the exception of the work with

aluminum electrodes, this is the only record of the failure of a hydrogen discharge to make a considerable improvement.

The results of a third a-c run up to 0.6 mm, the longest gap which could be broken down with the available a-c power, are shown in Fig. 58, page 118. This and Fig. 56, page 116, have the same scales as the earlier curves for steel, Figs. 9 to 16 on pages 69 to 76, so that comparisons may be readily made. A comparison of Figs. 58 and 56 indicates that the third a-c test made the gap worse except possibly for the smallest spacings. The d-c points at 1 mm in Fig. 58 show a considerable deterioration. The series of a-c tests seem to have been most beneficial only at the short gap lengths.

A review of the work with steel electrodes under the porcelain bushing suggests the following conclusions in regard to conditioning by breakdown. Referring to Figs. 51 to 53, pages 111 to 113, the effect of continued sparking with cyclic gap-length variation, essentially between the limits of 0.5 and 40 mm, was to raise the long-gap end of the curve at the expense of the remainder of it. Apparently continued sparking causes continued surface cleaning, spreading to the outer regions of the test spot to cause improvement to be shown each time the long-gap end is reached. The fact that continued sparking with this cyclic gap-length variation caused deterioration of the short gaps indicates the development of excessive cathode roughening.

The first a-c sparking at 0.5 mm caused a reversal of the above trend. As may be seen by comparison of Figs. 53 and 54, pages 113 and 114, the short gaps were now improved at the expense of longer ones. For the short gaps, values slightly higher than any preceding ones of this group of tests signifies a somewhat better electrode surface condition than in the preceding tests. For the long gaps, however, some deterioration is evident. In this case, the region of strong field likely spreads beyond the region in which the a-c discharge occurred. The fact that this is accompanied by values lower than the preceding may be due to material deposited on the regions surrounding the a-c discharge.

Figs. 55 and 56 on pages 115 and 116 show that a second a-c discharge (of longer duration) causes a general deterioration of gap characteristics except for the short range of distance in which the a-c breakdown had occurred. The change in this case is similar in direction to that of the case just reviewed.

Fig. 57 on page 117 represents the results of a hydrogen discharge applied to electrodes roughened by a-c breakdown. Since these curves are lower than those of Fig. 55, it may be concluded that the a-c sparking left the surfaces in a cleaner condition than the hydrogen discharge. (In spite of this, better d-c results have been obtained after a hydrogen discharge had been applied to a surface which

had not been roughened by a-c sparking. That is, the additional roughness occurring with the relatively powerful a-c breakdown more than offsets its resulting cleaner surface.)

The similarity of the a-c points in Figs. 15, 56, and 58, pages 75, 116, and 118, leads to the conclusion that the more powerful a-c breakdown is little affected by previous electrode conditioning - which might be expected in the case of a test that actually causes the removal of appreciable material. A comparison of these figures with Fig. 11, page 71, checks the conclusion in the preceding paragraph, that, as may be judged by the d-c tests of this investigation, the hydrogen discharge excels the a-c breakdown as a means of electrode conditioning.

The shape of many of the voltage-distance curves in Figs. 9 to 58 suggests an empirical equation similar to that of Froelich, or

$$v = \frac{Ad}{B + d},$$

in which A and B are constants. Since the relation may be written as

$$\frac{d}{v} = \frac{B}{A} + \frac{d}{A},$$

data corresponding to it should produce a linear plot of the reciprocal of gradient versus spacing. Fig. 59, page 124, shows such a plot for the data of Fig. 52, page 112.

The constants corresponding to the straight line are:

A = 590 kv and B = 0.77 cm. Since, as d is increased indefinitely, the above expression for v approaches the limit A,

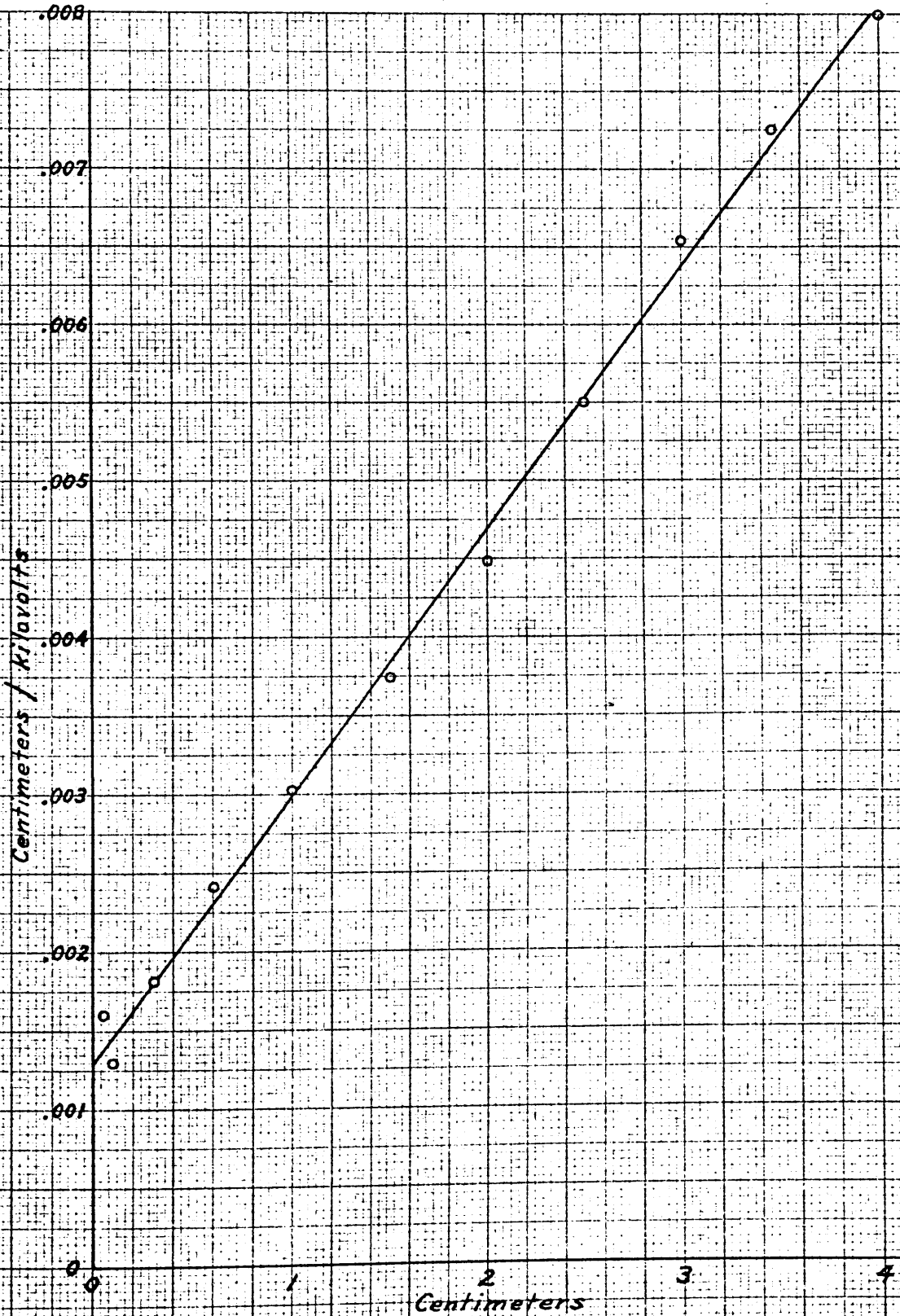

Fig. 59. Reciprocal of gradient versus gap length.
from data of Fig. 52

the equation would correspond to the condition that there is a ceiling of voltage which can not be exceeded between the electrodes. From the expression for v ,

$$\frac{v}{d} = \frac{A}{B + d} .$$

This would correspond to the condition that gradient decreases continuously from a fixed value at zero gap length.

BREAKDOWN VOLTAGES COMPARED WITH WORK FUNCTIONS

A correlation might be expected between the breakdown results of this investigation and the work functions of the materials tested. Those materials for which the latter data were available are tabulated in Table VII with cold-rolled steel classed as iron. The first column of numbers gives

Table VII. Comparison of Breakdown Voltages, for 1-Mm Gap, with Work Functions

Metal	Breakdown Voltage in Kv	Thermionic Work Function in Volts	Photo-Electric Work Function in Volts
Iron	122	3.2*	
Nickel	96	2.75 [†]	
Molybdenum	92	4.31*	
Copper	37		4.1*
Aluminum	41		2.8*

* Smithsonian Physical Tables (1933), p.549.

[†] International Critical Tables (1929), v.6, p.53.

the average breakdown voltage with a 1-mm gap, as determined from representative data of this investigation. The second and third columns of numbers give values of work functions. For the first three metals, only thermionic work functions could be found; and for the last two metals, only photoelectric work functions were available. Apparently there is no correlation between breakdown voltages and work functions.

SUMMARY

The following is a summary of important observations from the breakdown measurements:

Of the materials tested, the best results were obtained with cold-rolled machinery steel and 18-8 (respective percentages of chromium and nickel) stainless steel.

As a part of electrode conditioning, sparking is essential, but may advantageously be preceded by a hydrogen discharge between electrodes. The advantage of the hydrogen discharge is that better insulating properties may be obtained with less severe sparking. Sparking has the disadvantage of causing roughening, but some roughening is produced by discharges even at voltages below that at which breakdown starts. Consequently sparking might as well be allowed. It has the advantage of producing a considerable improvement in insulation - both from the viewpoint of reducing leakage current and raising breakdown voltage. Sparking should take place with each polarity in order that

the cleaning which is characteristic of the anode may be given each electrode.

A high polish is not essential, and may likely be detrimental on account of imbedded abrasive. The smoothing of a machined piece may best be accomplished with fine emery paper rather than loose abrasive material.

As electrode separation is increased, voltage can not be increased at a rate to maintain constant gradient. This is dealt with in greater detail in the following chapter.

CHAPTER VI
THE TOTAL-VOLTAGE EFFECT

CATHODE GRADIENTS

Discussion preparatory to the consideration of observed relations between breakdown voltage and gap length follows. As electrode separation is varied, constant average gradient along the shortest line between the electrodes is maintained if voltage is varied in direct proportion to distance, or

$$v_1 = K d. \quad (1)$$

On the basis of smooth geometric surfaces, maximum gradient on the plane cathode opposite the spherical anode is related to the average gradient by a factor f_1 , which decreases from unity as distance is increased from zero, as shown in Fig. 6, page 34. Considering this factor, the maintenance of constant maximum cathode gradient during the increase of distance would require that voltage be increased somewhat more than in direct proportion to distance. Voltage given by (1) would have to be divided by the value of f_1 at each distance, or

$$v_2 = K \frac{d}{f_1}. \quad (2)$$

To determine the manner in which the above should be modified in order to take into account the effect of a surface irregularity, reference is first made to Bateman.¹

1. H. Bateman, Partial Differential Equations of Mathematical Physics, Cambridge University Press, 1932, p.436.

By representation of a surface peak as an ellipsoidal column projecting above a plane, it is shown in the case of a mathematically infinite separation from another plane that there will be a definite ratio of concentration of gradient on the peak of this projection. That is, the maximum gradient on the projection will equal that which would exist on a smooth plane multiplied by the ratio of concentration, which will be designated f_2 .

Obviously if the plane with the projection and the opposite smooth plane are moved toward each other, the above ratio of concentration will continuously increase, becoming very large as separation becomes comparable to the height of the projection. Thus f_2 is an inverse function of distance.

In the above case the projection is located in a region where the electrostatic field would have been uniform in its absence. In the case of plane and spherical electrodes, an essentially similar condition is obtained if such a hypothetical peak, small compared to the sphere, is mounted on the plane at the base of the shortest line between the plane and sphere; and the gradient at the peak of the projection becomes equal to the gradient which would exist in its absence multiplied by the ratio of concentration, f_2 . Therefore, if the gradient at the peak of such a projection is to be held constant while electrode separation is varied, voltage v_3 would have to be adjusted so as to equal v_2

divided by f_2 , or

$$v_3 = K \frac{d}{f_1 f_2} . \quad (3)$$

Since f_1 and f_2 are inverse functions of distance, the voltage to maintain a constant maximum gradient on the assumed irregularity would vary in more than direct proportion to distance.

If voltage is increased in direct proportion to distance while the above electrodes are being separated, obviously maximum cathode gradient can not increase. For the actual case of a cluster of different types of peaks on both the plane cathode and spherical anode, there occurs to the writer only one way in which a similar statement regarding maximum cathode gradient might be vitiated. As the distance between the plane and spherical electrodes is increased, a larger area of the cathode comes under the influence of a relatively strong field. If the newly exposed region contains a peak sufficiently sharper than any at the center, it might seem possible for an increase of distance to be accompanied with an increase of cathode gradient. However, if maximum cathode gradient is related to breakdown voltage, to account for the smooth experimental curves of breakdown voltage versus distance it would be necessary for the cathode to have surface irregularities graded in sharpness as a function of distance from the center of the test spot. Therefore, with the electrodes of the breakdown tests, an increase of electrode separation accompanied with a pro-

portionate increase of voltage could not produce an increase of cathode gradient, unless there exists during the tests a very special type of distribution of cathode irregularities.

The experimental curves of breakdown voltage have been (with the exception of Figs. 48 and 49, pages 108 and 109, for aluminum, to be discussed below) curves of continuously decreasing slope. Therefore, either

- (1) breakdown occurs at a continuously lower maximum cathode gradient as electrode separation and voltage are increased,
- or,
- (2) there exists during the tests the above-mentioned distribution of cathode irregularities.

POSSIBLE ROLE OF POSITIVE IONS

If the above condition 1 is valid, the current which leads to breakdown must be due to more than the cold emission of electrons, because, as gap length and voltage are increased, breakdown occurs at continuously lower cathode gradient. This could be explained on the basis that, as gap length and voltage are increased, the higher-voltage electron bombardment causes positive-ion emission from the anode. The latter could by bombarding the cathode cause further electron emission.¹ In this manner, high-voltage breakdown at lower cathode gradients could be explained.

1. L.H.Linford, The Emission of Secondary Electrons from Various Metal Targets, Bul. Am. Phys. Soc., v.9, n.3, p.8.

As a check upon the validity of the above explanation, two experiments were made:

(1) Electrodes of different materials were used to determine whether anode material is actually deposited on the cathode, which would result if positive ions play the role stated above.

(2) Apparatus was constructed for the measurement of interelectrode current, as a function of voltage and electrode separation, in a region of uniform field and constant known electrode area.

These experiments and their results are described below.

ELECTRODES OF DIFFERENT MATERIALS

For an experiment with electrodes of different materials, tests were made with a steel plate and a copper sphere, with polarity such that the copper was at all times the anode. At the first test point on the steel plate, with a 3-mm gap, voltage was applied by the belt generator with its corona leak in a remote position. After about 20 minutes, a light brown spot could be seen on the steel plate, tapering in density at its edges but quite distinct within about a 5-mm circle. Since a single spot of this sort might be attributed to the pulling off of loose anode material by electrostatic attraction, the above procedure was repeated at a second point on the steel plate; and produced the same result. At a third point, a voltage-distance run was made, for which results are plotted in Fig. 60, on the next page.

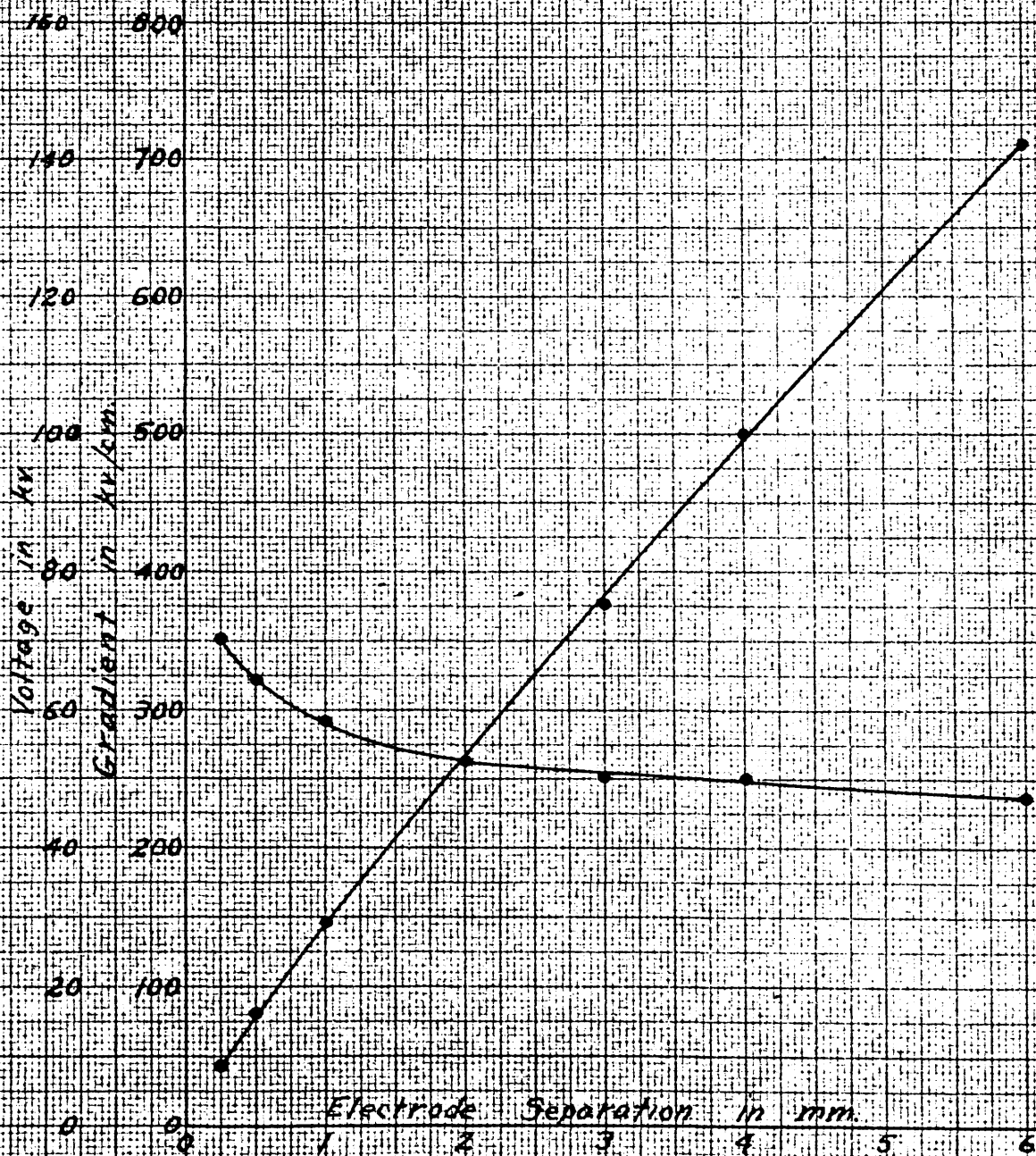

Fig. 60. Voltage and gradient vs electrode separation
Plate maintained negative throughout

Steel vs copper

Cathode, steel, 42-mil plate, unpolished

Anode, copper, 1-in. sphere

Electrodes not conditioned

An interesting feature of these curves is that they closely agree with those for copper electrodes, Figs. 41 to 45, pages 101 to 105; and distinctly differ from those for steel, Figs. 9 to 16, pages 69 to 76. Since interelectrode current was initiated by cathode emission, the fact that these electrodes display the characteristics of the anode material is alone an indication that this material is carried to the cathode. As a further check, however, the brown spots on the steel plate were spectroscopically analysed, and gave strong copper lines, which were entirely missing from other portions of the steel plate.

The results of the tests with polished aluminum electrodes gave nearly linear voltage-distance curves, as shown in Figs. 48 and 49, pages 108 and 109. This corresponds to an unusually slow decrease of cathode gradient with voltage, and suggests that interelectrode current in this case might be mostly due to cathode emission. This material seemed therefore an interesting one to try with a steel cathode, to see if aluminum would be carried across to the cathode; and a test was run following essentially the same procedure as that for the test with copper and steel. Three faint spots were formed upon the steel plate, and measurements gave the curves shown in Fig. 61, page 135, which obviously agree with those for aluminum electrodes, Figs. 46 to 49, pages 106 and 109. Spectroscopic analysis, however, revealed an interesting fact. This steel, with which some

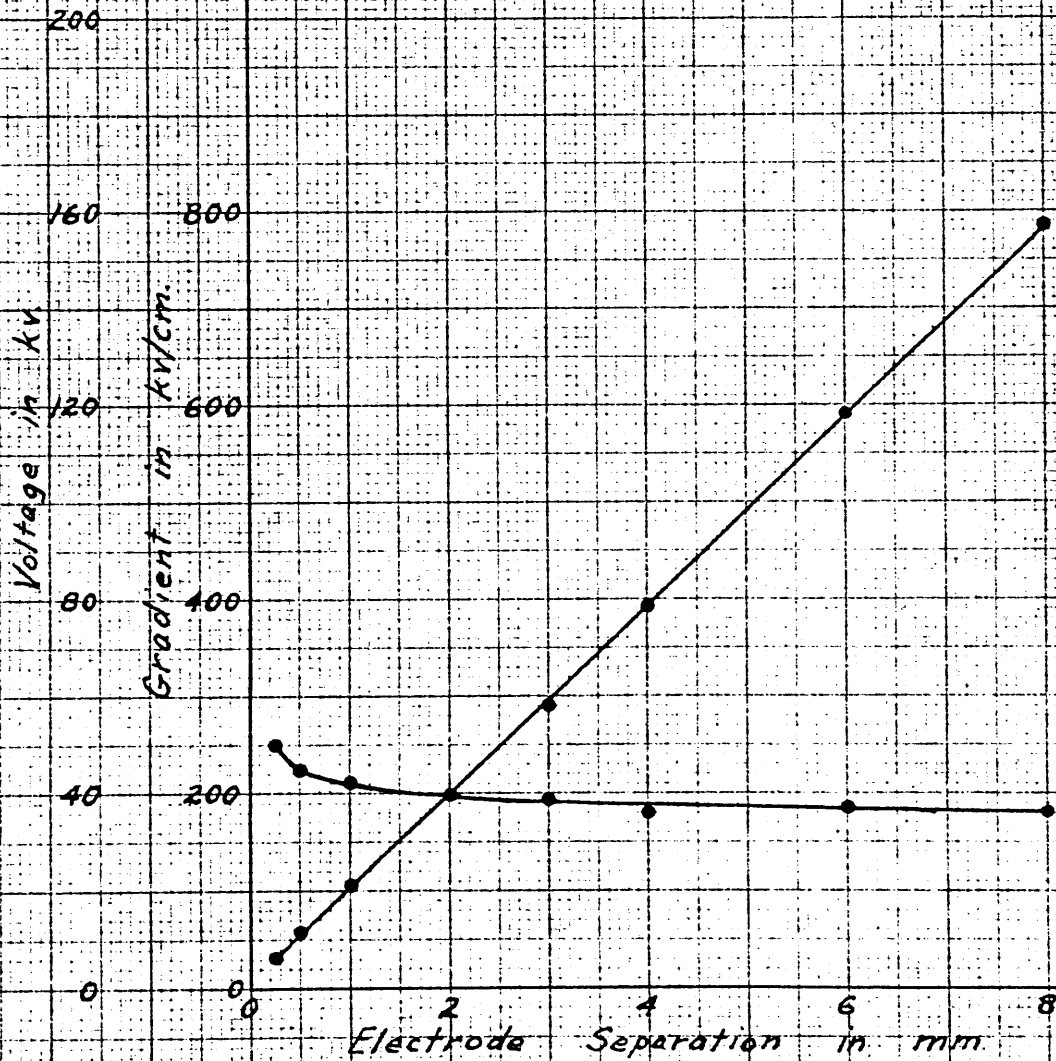

Fig. 61. Voltage and gradient vs electrode separation

Plate maintained negative throughout

Steel vs aluminum

Cathode, steel, 42-mil plate, unpolished
Anode, aluminum, 1-in. sphere

Electrodes not conditioned

of the best results of this work have been obtained, showed a trace of aluminum, with which the poorest results have been obtained. This presence of aluminum prevented positive identification of the spots on the steel plate.

ELECTRODES FOR CURRENT MEASUREMENTS

A description of the apparatus for the measurement of interelectrode current in a region of uniform field and known electrode area follows. The conditions to be secured for this work suggest the use of flat circular electrodes with guard rings; but guard rings, however well fitted, would produce some edge effect. Since cold emission is a function of cathode gradient, any arrangement of cathode guard rings is open to serious question. For the anode, however, the edge effects of a guard ring would be much less serious. (An anode gradient of 35×10^6 volts per cm has been shown to produce no detectable current.¹) In view of these considerations it was decided to use a guard ring on the positive side of the gap.

In the first part of this work a voltage-measuring gap was constructed² in accordance with a design³ which was intended to produce a uniform field and therefore a linear

1. Eyring, Mackeown, and Millikan, Field Currents from Points, Phys. Rev. 31, May, 1928, p. 909.

2. See page 16.

3. J.D. Stephenson, Corona and Spark Discharges in Gases, Jr. I.E.E. 73, July, 1933, p. 69.

scale of calibration. Its electrode arrangement is sketched in Fig. 62. It has been noted that, within the range of gap length for which this design was intended, breakdown of this gap occurred at random points on the flat surfaces where the field should be uniform. Also its calibration curve was practically linear within the prescribed limits

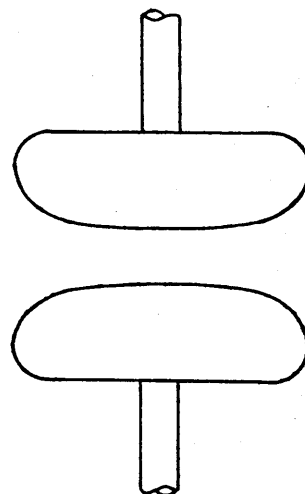

Fig. 62. Electrodes of voltage-measuring gap

of gap length. Therefore it was concluded that this type of electrode really produces a substantially uniform field, and it was planned to adopt it for the present work.

If both electrodes were of the above type, two conditions of alignment would have to be fulfilled: (1) paralleling of the flat surfaces, and (2) adjusting the electrodes to a common center line. In order to avoid condition 2, it was decided to use an anode of the above type with a plane cathode. This had the further advantage that it avoided a convex cathode surface at points near the anode, where there might be some question of slight inaccuracies of curvature and the possibility of regions of slightly increased cathode gradient. Data for this modified plan were of course readily deduced from that of Fig. 62 by considering the plane surface to be midway between the electrodes.

The anode for this work was constructed of rolled nickel having less than 1 percent of impurity. It may be seen in the photographs of Figs. 2 and 3, pages 24 and 25, and is shown in full-scale section in Fig. 63.

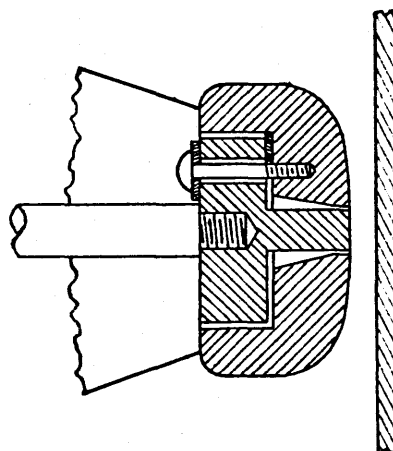

Fig. 63. Guard-ring anode and flat cathode

In the diagram, one of 3 equally spaced screws is shown, with an insulating mica washer under its head. Also one of 3 equally spaced mica separators is shown between the inner and outer sections of the anode and adjacent to the screw. On the face of the anode and for a short distance inward, radial clearance between the inner and outer parts was 3 mils. The edges, formed by this circular groove of clearance, were very slightly rounded. The diameter of the central core was 0.244 in. Within a 0.3-in. circle at its center, the face of the anode was ground flat. At the edge of this circle, the surface ran tangentially into a curve having a 3.1-in. radius, which continued outward to a radial distance of 0.45 in. Beyond this point the radius was shortened to bring the curve tangentially into an element of the outside cylindrical surface, of which the diameter was 1.5 in.

As may be judged by the performance of the voltage-measuring gap, and the paper describing it, the above electrode should with an opposite plane provide a substantially uniform field within a 0.3-in. circle for spacings up to 0.16 in. or about 4 mm. Slightly beyond this spacing the region of most intense field will move outward to a ring at the edge of the 0.3-in. circle, as may be seen by observing the position of breakdown on the voltage-measuring gap. If the gap length is carried still further, the ring of most intense field will expand toward the edge of the guard ring.

As shown in Fig. 63, a central rod extended back from the anode. This was carried to the center of the Pyrex insulator of Fig. 4, page 26, from which point a shielded lead was brought out of the vacuum tank. As may be seen in Fig. 63 and Fig. 3, page 25, a piece of conical shielding was placed between the outer part of the anode and the shielding of the electrode mechanism.

With this guard-ring anode, various flat cathodes were used: electrolytic nickel and steel accurately ground to flat surfaces, and unground rolled nickel and steel. The latter were tried as a check against the possible influence of imbedded grinding material. The cathode plates were adjustable in position by means of small screws with lock nuts, as may be seen in Fig. 2, page 24. In each case the cathode was accurately paralleled with the flat portion of the anode. The condition of parallelism was determined by

sighting toward a lamp placed on the opposite side of the electrodes from the observer.

CURRENT MEASUREMENTS

The object of constructing this guard-ring anode was to determine whether interelectrode current is a function of cathode gradient alone, or whether it may also depend upon voltage. In order to make the most direct experimental approach to this determination, two types of procedure were followed:

(1) With a succession of gap lengths, the voltages required to produce a given single value of current were determined. From such data, gradient, as a function voltage or distance, can be determined for the value of current used.

(2) With each of a succession of gap lengths, a voltage in proportion to gap length was applied. Thus, current values were obtained as a function of voltage with constant gradient.

Curves of gradient to maintain a given current may be plotted as functions of either voltage or distance. Such a curve is shown plotted both ways in Fig. 64, page 141. In each case, it will be noted that the current was maintained with continuously less gradient as separation and voltage were increased.

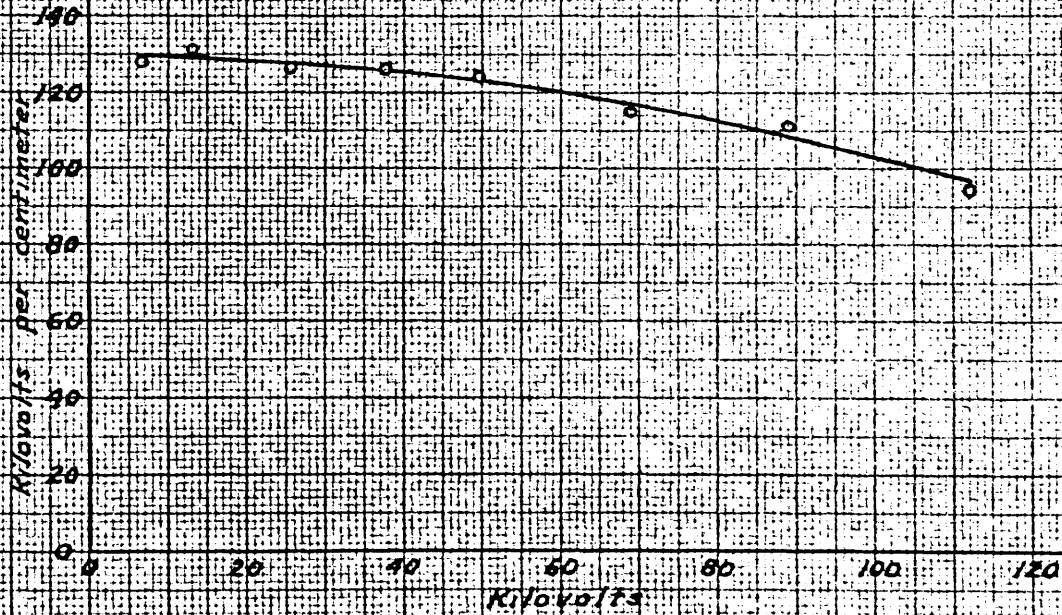
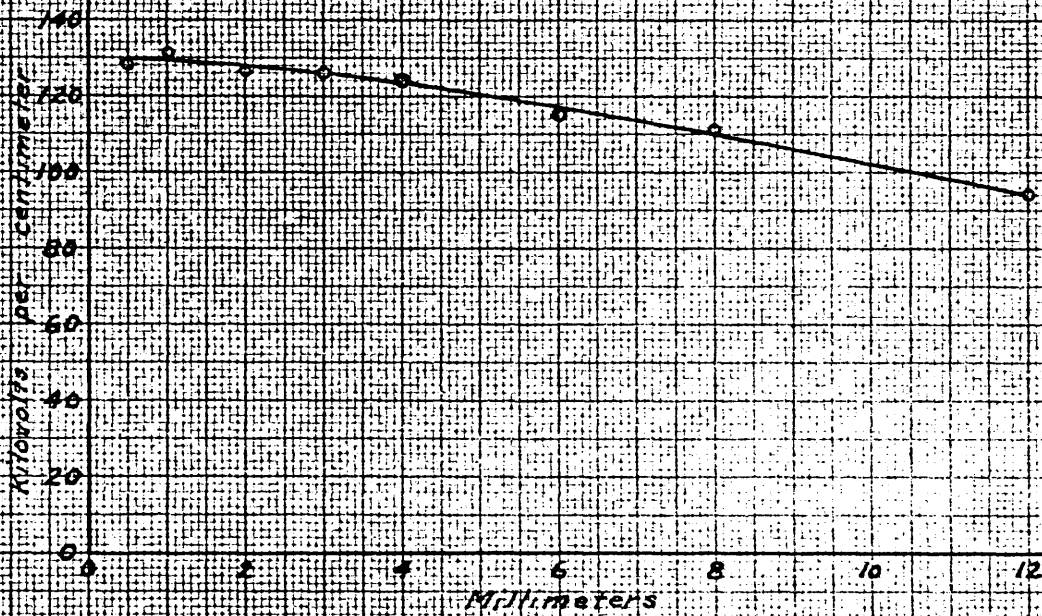

Fig. 64. Gradient to maintain a current of 1.5×10^{-9} amp versus gap length and voltage, from measurements with guard-ring anode

Nickel electrodes
Cathode conditioned with electron bombardment

Results of individual runs at constant gradient are shown in Fig. 65, page 143, and a family of curves for three different gradients is shown in Fig. 66, page 144. These curves show the converse relation of the previous group. As constant gradient is maintained during an increase of distance and voltage, larger currents are produced. Since an increase of voltage can, without increasing gradient, increase interelectrode current, current is found to be a function of voltage as well as cathode gradient.

SUMMARY OF POSITIVE-ION INDICATIONS

As previously stated, this dependence of current upon voltage as well as cathode gradient involves the condition that positive ions play a part in high-voltage conduction between electrodes in high vacuum. The various observations of this investigation which have pointed to such a conclusion are here summarized:

- (1) During breakdown, the cathode as well as the anode becomes roughened.
- (2) Curves of breakdown voltage versus electrode separation continuously decrease in slope.
- (3) Curves of breakdown voltage versus electrode separation depend in a marked degree upon anode material, and it has been definitely shown that anode material is deposited upon the cathode.
- (4) Interelectrode current at constant gradient

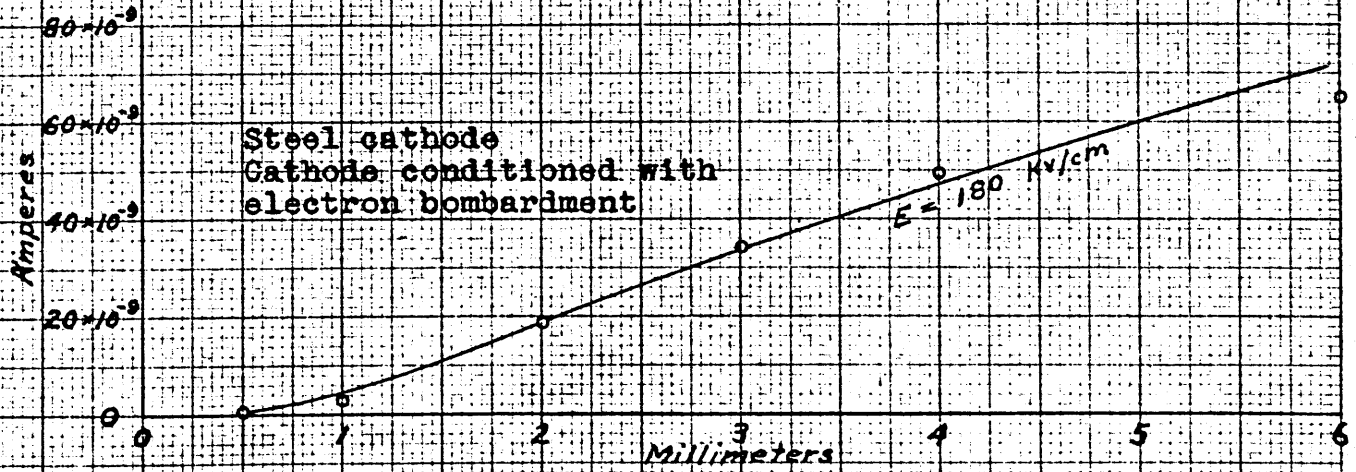
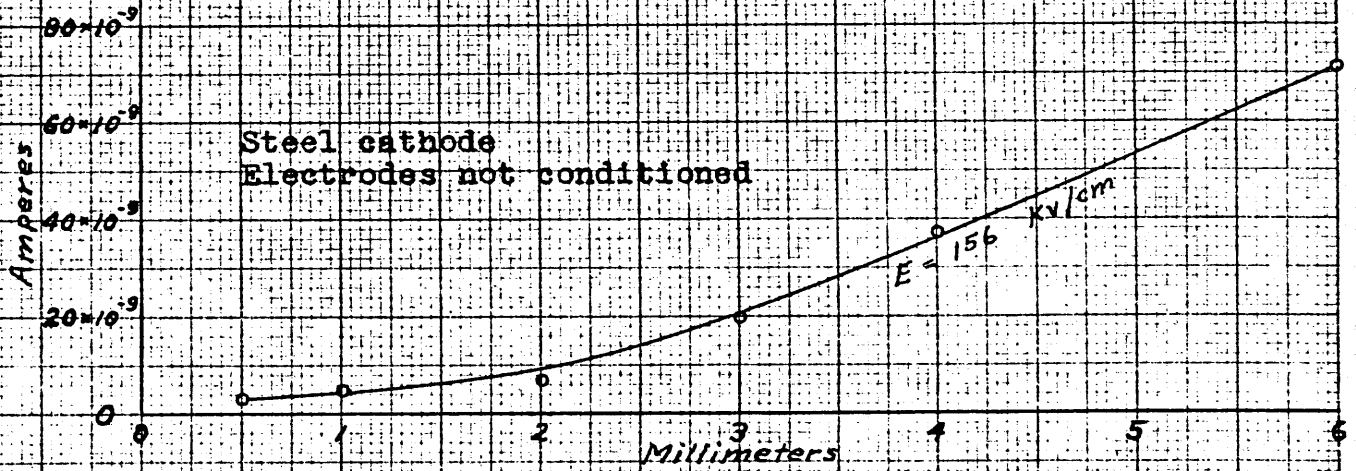
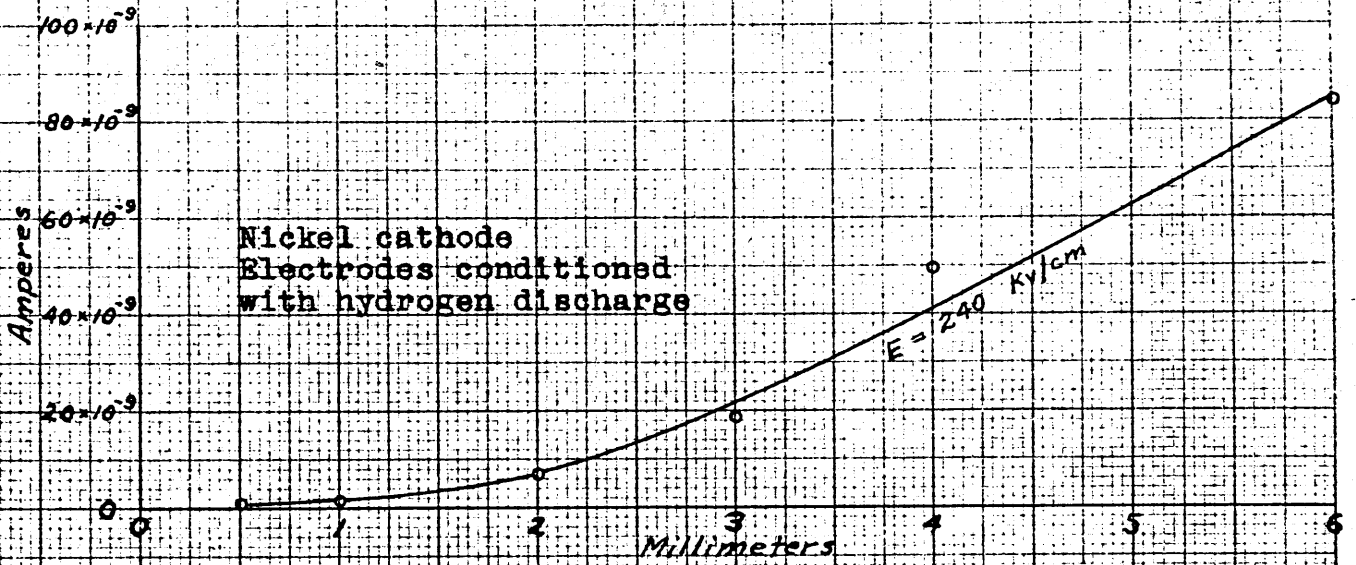

Fig. 65. Current at constant cathode gradient vs gap length, from measurements with nickel guard-ring anode

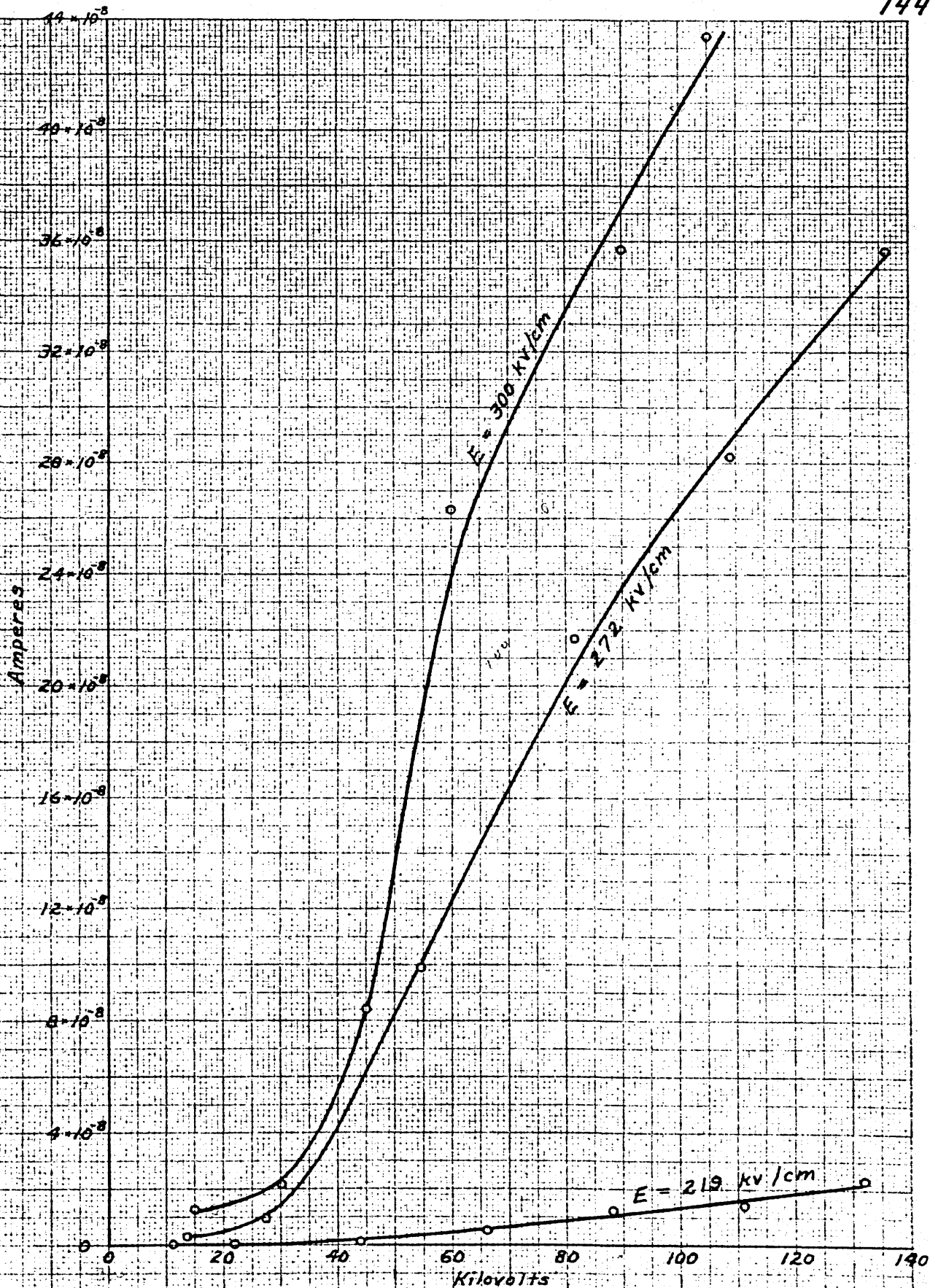

Fig. 66. Current at constant cathode gradient vs voltage, from measurements with guard-ring anode

Nickel electrodes conditioned with hydrogen discharge

(and constant electrode area) varies by a large factor with voltage between electrodes.

AMOUNT OF CONDUCTION BY POSITIVE IONS

To determine the fraction of interelectrode conduction which is due to positive ions, a test was made with steel electrodes consisting of a 1-in. sphere and a hemispherical shell of approximately the same radius. The latter was supported by small nickel wires (which are poor conductors of heat), and was fitted with a thermocouple that had been welded to its inside surface, and was on the ground side of the system. With this arrangement, one electrode had a relatively small thermal capacity and was supported by poor conductors of heat; and its temperature could be measured. The other electrode had a relatively large thermal capacity and was in contact with other heavy metal parts. Thus, in case it should receive the greater proportion of total power, its temperature would be prevented from rapidly rising above the other electrode to a point at which appreciable heat transfer by radiation would take place. With the apparatus in thermal equilibrium, runs were made with each polarity, and with a gap length of 2.9 mm, a voltage of 120 kv, and a current of 4×10^{-5} amp. The rate of temperature rise of the hemispherical shell as anode was 290 times its rate as cathode. Consequently, under the above conditions, positive-ion conduction amounted to 0.35 percent of electron conduction.

THE TOTAL-VOLTAGE EFFECT

As a designation for the dependence of interelectrode current upon voltage (in addition to gradient), the term "total-voltage effect" has been suggested by Dr. R. J. Van de Graaff, who predicted its existence.¹ This effect represents a factor which, besides cold emission, must be dealt with in high-voltage vacuum insulation.

1. Van Atta, Van de Graaff, and Barton, A New Design for a High-Voltage Discharge Tube, Phys. Rev. 43, Feb., 1933, p. 158.

CHAPTER VII

CONCLUSION

From the separate conclusions reached at various points during the work, important items and suggested future research are summarized below.

ELECTRODES

The best electrode materials found in this investigation are cold-rolled machinery steel and 18-8 stainless steel. Of the materials tested, these are outstanding. Surfaces of electrodes should, if machined, be fairly free of tool marks and smoothed with fine emery paper. Surfaces of cold-rolled stock often could not be improved by any sort of smoothing process tried. The process of polishing and buffing is not essential and may prove detrimental. Cleaning surfaces with carbon tetrachloride and alcohol proved to be as satisfactory as any method tried.

In the vacuum tank, desirable conditioning can be obtained by running a hydrogen discharge between electrodes. For this purpose, a current density on the electrodes of 0.25 amp per sq cm during a 3-minute period has been found satisfactory. After a high vacuum has been produced, a period of sparking between electrodes is a beneficial sequel to the hydrogen discharge. If d-c power is used for this

sparking, polarity should occasionally be reversed. The power supply should in any case have a current-limiting characteristic in order to prevent the formation of power arcs. If electrode spacing can be varied, it may advantageously be increased to as much as double normal value during sparking.

The above process of conditioning in the vacuum tank should precede the actual application of operating voltage by the shortest practicable time, and should be repeated if the electrodes have been without voltage for many hours. (The latter provision may be unnecessary in a very clean and thoroughly outgassed system.)

In future research, a substitute for sparking as a means of conditioning may well be sought. Sparking often causes severe electrode roughening, and in cases of greater power causes the removal of appreciable electrode material.

The coating of the cathode with an insulating film should be studied, but may possess inherent difficulties. Anode material coming toward the cathode would be expected to puncture such a film. Even if immediate puncturing should not result, anode material might be deposited upon the film and cause local emission, with resulting electrostatic stresses in the film. Gas from the underlying metal and obvious mechanical difficulties would also seem to be causes of trouble.

The present investigation has indicated that a cathode

material differing from that of the anode can not be maintained, on account of the deposition of the latter upon the cathode.

CEILING OF VOLTAGE

As a consequence of the total-voltage effect, a ceiling of voltage, which can not be exceeded between electrodes, might be expected to exist. The part of this investigation, for which the apparatus of Figs. 2, 3, and 4 was used, indicated the existence of such a ceiling at about 400 kv with the best electrodes found. That is, the extrapolation of the steepest curves of breakdown voltage versus spacing appeared to become horizontal at about this voltage. (Such extrapolation must of course be recognized as an inherently vague process. More definite information about the higher-voltage ranges would have to be obtained with actual tests at the higher voltages.) Later measurements of breakdown voltage were made with the same materials, but in the compartment under the lead-in bushing shown in Fig. 8. In this case a smaller cathode plate was used, which was less favorable from the viewpoint of cathode gradient at its edges. But in this case, considerably higher voltage could be put upon the electrodes on account of the increased distance for external flashover and a more favorable arrangement of internal high-voltage parts. The result of the one different factor made possible by this new arrangement of appa-

ratus - higher voltage sparking - caused the apparent ceiling of voltage to be changed from 400 to 700 kv. In the runs which indicated the higher ceiling of voltage (Figs. 50 to 58), the large lead-in bushing frequently flashed over externally. Consequently, if runs were made with a still larger bushing and a different generator capable of producing higher voltages than the one used in this investigation, it seems very probable that a still higher ceiling of voltage would be found as a result of conditioning by sparking at higher voltages. In future research, this should be investigated.

For a vacuum-insulated transmission line, a cylinder with a concentric central conductor has been proposed. For 1000 kv service, an outer cylinder with a 10-in. inside diameter and a 1.5-in. central core have been suggested.¹ This arrangement of conductors differs from any electrode arrangement of the present investigation in two important ways: (1) the electrodes are concentric cylinders instead of a sphere and plane, and (2) the spacing is 2.5 times the greatest for which any sort of data have been obtained. As a result of condition 1, the line (with its outer cylinder as cathode) would be expected to have relatively small cold-cathode emission, but there would be a strong gradient at the anode, and electron bombardment would be concentrated

1. J. G. Trump, Vacuum Electrostatic Engineering, M.I.T., Sc.D. Thesis, 1933, p. 114.

upon it. In spite of condition 2, the present investigation has not shown that a voltage greater than 700 kv can be supported by the line. Allowing a factor of safety of 4, the corresponding operating voltage would be 175 kv. At this voltage, smooth-surface cathode gradient on the inside surface of the outer cylinder would be 7.3 kv per cm. This gradient is but a small fraction of that at which any leakage current was detected in this entire investigation. Consequently the loss of the line due to leakage current in the vacuum would likely be very small.

Future research might well include an investigation of concentric conductors as electrodes in vacuum.

SAFE OPERATING GRADIENTS FOR MACHINERY

From the maximum breakdown of this investigation, it may be possible to make an estimate of the safe operating values of gradients which may be used between electrodes of an electrostatic machine. For this purpose, the experimental values of breakdown voltage have been divided by 6. The basis of this is to allow a factor of 1.5 for edge effects, a factor of 2 for transients, and an additional general safety factor of 2. The results thus obtained for the best material, steel, are given in Table VIII. They have been computed from average instead of cathode gradients, on the following basis. Up to 2 mm the plane-and-sphere correction (Fig. 6) is not appreciable. Above 2 mm the

work was done with a cathode consisting of a 2-in. disk, and it was considered that its edge effects compensate for the above correction.

Table VIII. Safe Operating Gradients for Machines with Steel Electrodes as a Function of Electrode Separation

Electrode Separation in Cm	Average Gradient in Kv/Cm
0.1	225
0.2	155
0.5	78
1.0	55
2.0	37
3.0	29

An estimate of power concentration in an electrostatic generator has been based upon an ultimate operating gradient of 2000 kv per cm with a 0.5-cm electrode separation.¹ At the present stage of the work on vacuum insulation, 78 kv per cm would have to be considered the operating gradient for this spacing. Consequently, for the same power, the volume of dielectric of the above machine would have to be multiplied by a factor of $(2000/78)^2$ or about 660.

It should be borne in mind that the above data concerning operating gradients are based upon evidence available at present. It is quite possible that further research may

1. J. G. Trump, loc. cit., p. 73.

produce means of materially increasing these gradients by virtue of better electrode materials or methods of conditioning.

THE TOTAL-VOLTAGE EFFECT

The total-voltage effect, illustrated by the above reduction of gradient with distance, may well be investigated further. Since this effect was most definitely established with the guard-ring anode, its further use is recommended. In order that a uniform field may be obtained with greater spacings, the writer would suggest that the dimensions given in the discussion of Fig. 63 be multiplied by 3. Also he would suggest that the anode be made of steel, which is superior to nickel with respect to breakdown voltage, and for which such information should be obtained. A power supply to be used with this device should have a larger current capacity than the present generator at least by the ratio of electrode areas. Consequently, a generator should be constructed with at least 9 times the current capacity of the present one. With this larger electrode and a more powerful (with respect to voltage as well as current) generator, valuable additional quantitative information could be obtained concerning leakage current between steel electrodes at high voltages.

BIBLIOGRAPHY

1. R.W.Wood, A New Form of Cathode Discharge and the Production of X-Rays, together with Some Notes on Diffraction, Phys. Rev. 5, July, 1897, p.1.
2. R.A.Millikan and R.A.Sawyer, Extreme Ultra-Violet Spectra of Hot Sparks in High Vacuum, Phys. Rev. 12, 1918, p.167.
3. R.A.Millikan and Shackelford, On the Possibility of Pulling Electrons from Metals by Powerful Fields, Phys. Rev. 15, 1920, p.239.
4. W.Schottky, Über Kalte und warme Elektronenentladungen, Zeit. f. Phys. 14, 1923, s.63.
5. R.A.Millikan and C.F.Eyring, Laws Governing the Pulling of Electrons Out of Metals by Intense Fields, Phys. Rev. 27, Jan. 1926, p.51.
6. Research Staff of the G. E. Co., London, The Emission of Electrons under the Influence of Intense Electric Fields, Phil. Mag. 1, Mar., 1926, p.609.
7. C.F.Eyring, S.S.Mackeown, and R.A.Millikan, Field Currents from Points, Phys. Rev. 31, May 1928, p.900.
8. R.A.Millikan and C.C.Lauritsen, Relations of Field Currents to Thermionic Currents, Proc. Nat. Acad. 14, 1928, p.45.
9. C.C.Lauritsen and R.A.Millikan, Different Types of Field Currents, Their Laws and the Conditions under Which They Arise, Phys. Rev. 31, May, 1928, 914.
10. Stern, Gossling, and Fowler, Further Studies in the Emission of Electrons from Cold Metals, Proc. Roy. Soc. 124, 1929, p.699.
11. K.T.Compton and I.Langmuir, Electrical Discharges in Gases, Part I, Rev. Mod. Phys. 2, Apr., 1930, p.123.
Part II, Rev. Mod. Phys. 3, Apr., 1931, p.191.
12. W.H.Bennett, Cold Emission from Unconditioned Surfaces, Phys. Rev. 37, Mar.1931, p.582.
13. W.H.Bennett, Effect of Target on Breakdown in Cold Emission, Phys. Rev. 40, May, 1932, p.416.

14. C.C.Lauritsen and R.D.Bennett, A New High Potential X-Ray Tube, Dec., 1928, p.850.
15. M.A.Tuve, G.Breit, and L.R.Hafstad, Application of High Potentials to Vacuum Tubes, Phys. Rev. 35, Jan.,1930, p.51.
16. C.C.Lauritsen and B.Cassen, High Potential X-Ray Tube, Phys. Rev. 36, Sept., 1930, p.988.
17. G.Breit, M.A.Tuve, and O.Dahl, Laboratory Method of Producing High Potentials, Phys. Rev. 35, Jan., 1930, p.51.
18. R.Crane and C.C.Lauritsen, A High Potential Porcelain X-Ray Tube, R. S. I., 4, Mar., 1933, p.118.
19. J.D.Stephenson, Corona and Spark Discharges in Gases, Jr. I.E.E. 73, July, 1933, p.69.
20. Lord Kelvin, Reprint of Papers on Electrostatics and Magnetism, Macmillan, 1884,
21. F.W.Peek, Jr., Dielectric Phenomena in High-Voltage Engineering, McGraw-Hill, 1929.
22. R.L.Stewart, Insulating Films Formed under Electron and Ion Bombardment, Phys. Rev. 45, Apr., 1934, p.488.
23. S.Dushman, Electron Emission, Elec. Engr. 53, July, 1934, p.1054.
24. Van Atta, Van de Graaff, and Barton, A New Design for a High-Voltage Discharge Tube, Phys. Rev. 43, Feb., 1933, p.158.