

LN-3 IDLE MIND SOLUTIONS

1. Let us first look in most general terms at the optical properties of solids with band gaps (E_g) of less than 4 eV, semiconductors by definition.

The band gap energy (E_g) can also be depicted as an “optical band edge”, as a barrier beyond which photons will excite electrons from the valence to the conduction band.

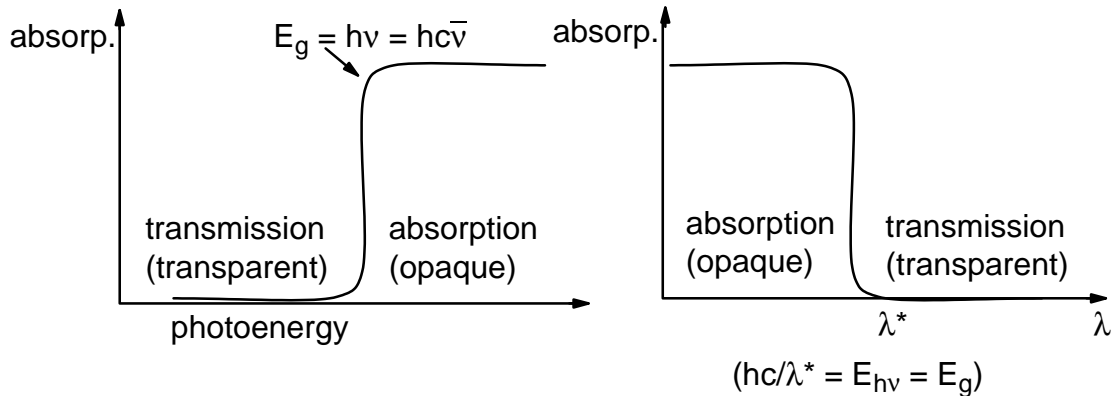

In the present case:

$$E_g = 3 \text{ eV} \times \frac{1.6 \times 10^{-19} \text{ J}}{\text{eV}} = 4.8 \times 10^{-19} \text{ J} = \frac{hc}{\lambda^*}$$

$$\lambda^* = \frac{hc}{4.8 \times 10^{-19}} = \boxed{4.14 \times 10^{-7} \text{ m}}$$

The optical band edge is at 4140Å, which means that from the daylight spectrum (sunlight) all λ 's less than 4140Å will be absorbed, all λ 's larger than 4140Å will be transmitted. The visible spectrum is normally given as ranging from 4000 to about 8000Å (in some texts from 4200Å to 7200Å). According to either definition, a λ of 4140Å is on the far end of the **violet**, bordering on the UV. This suggests that the solid is essentially transparent to the visible radiation and in transmission may have a slight orange tinge, provided there are no impurities or other defects in the material which provide for electronic transitions other than the v.b. to c.b. transitions.

2. The answer to this question is subject to the same restrictions as above. “Assuming” a defect-free and pure solid, then the color will be controlled by c.b. to v.b. transitions. A solid that appears green in transmitted light will absorb in the red (leaving yellow — green — blue → green). The amount of blue tinge in the green will be determined by the red cut-off location. Taking the optical band edge in the middle of the red, $\lambda^* \pm 6500\text{Å}$, we obtain for a band gap (E_g):

2. Continued.

$$E_g = E_{hv} = \frac{hc}{\lambda^*} = \frac{6.63 \times 10^{-34} \times 3 \times 10^8}{6.5 \times 10^{-7}}$$

$$= 3.06 \times 10^{-19} \text{ J} \times \frac{1 \text{ eV}}{1.6 \times 10^{-19} \text{ J}} = \boxed{1.9 \text{ eV}}$$

3. Both compounds are of the III–V family, which hybridize and form “adamantine” (diamond–like) structures which places them into the category of semiconductor.

AlN $\Delta EN = 1.43$. The covalent radii of the constituents are small and, combined with the large ΔEN , the bonds (polar covalencies) are very strong – the semiconductor is expected to **exhibit a large band gap** (likely transparent).

GaSb $\Delta EN = 0.24$. The covalent radii of both constituents are significantly larger (than those of AlN), the ionic contribution to bonding is small – the semiconductor is expected to **exhibit a much smaller band gap than AlN**.

(AlN, $E_g = 3.8 \text{ eV}$, GaSb, $E_g = 0.8 \text{ eV}$)

4. (a) Na 3s valence band is half–filled. Electrons may acquire additional incremental energy and move about (conduct).

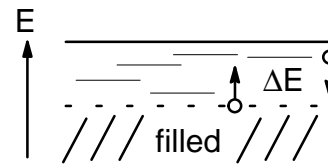

(b) Mg 3s valence band is completely filled; however, the 3p band, which is empty, partly overlaps the filled valence band and provides for electrical conductivity.

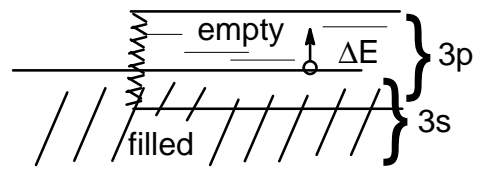

5. Considering electronic transitions only, the answer in principle is the same for all three materials: there is no limit. But rephrased ($\lambda = hc/E$) – which is the lowest energy radiation still capable of being transmitted through a material? – the question makes sense; we are concerned about a cut-off wavelength beyond which the radiation is being absorbed. Absorption means the energy is being transferred to an electron. Such a transfer can only take place if E (photon) $\geq \Delta E$. The critical energy ($E = hv = hc/\lambda$) is presently given by the value of the energy gap (E_g).

(a) Si: $E_g = 1.1\text{eV} = 1.1 \times 1.6 \times 10^{-19} \text{ J} = 1.76 \times 10^{-19} \text{ J} = hc/\lambda$

$$\lambda_{\text{crit}} = \frac{hc}{1.76 \times 10^{-19}} = 1.13 \times 10^{-6} \text{ m} = 1.13 \mu\text{m}$$

(b) Ge: $E_g = 0.7\text{eV} = 1.12 \times 10^{-19} \text{ J}$

$$\lambda_{\text{crit}} = 1.77 \times 10^{-6} \text{ m} = 1.8 \mu\text{m}$$

(c) GaAs: $E_g = 1.43\text{eV} = 2.29 \times 10^{-19} \text{ J}$

$$\lambda_{\text{crit}} = 0.87 \times 10^{-6} \text{ m} = 0.87 \mu\text{m}$$

6. An extrinsic semiconductor is a semiconductor which contains foreign elements capable of contributing mobile charge carriers, electrons, to the conduction band (n-type) or holes to the valence band (p-type). An intrinsic semiconductor contains no foreign elements.
7. The question is answered by determining (a) the volume of 50g Si and (b) the number of P atoms in 3 mg = 3×10^{-3} g P.

$$\rho_{\text{Si}} = 2.33 \text{ g/cm}^3; \quad \frac{50 \text{ g}}{2.33 \text{ g/cm}^3} = 21.46 \text{ cm}^3$$

$$30.97 \text{ g P} = 6.02 \times 10^{23} \text{ atoms} \quad \text{atomic weight of P} = 30.79 \text{ g}$$

$$3 \text{ mg} = 3 \times 10^{-3} \text{ g} = \frac{6.02 \times 10^{23} \times 3 \times 10^{-3}}{30.97} = 5.83 \times 10^{19} \text{ atoms}$$

$$\text{Number P atoms/cm}^3 \text{ silicon} = \frac{5.83 \times 10^{19}}{21.46} = 2.7 \times 10^{18}/\text{cm}^3$$

8.

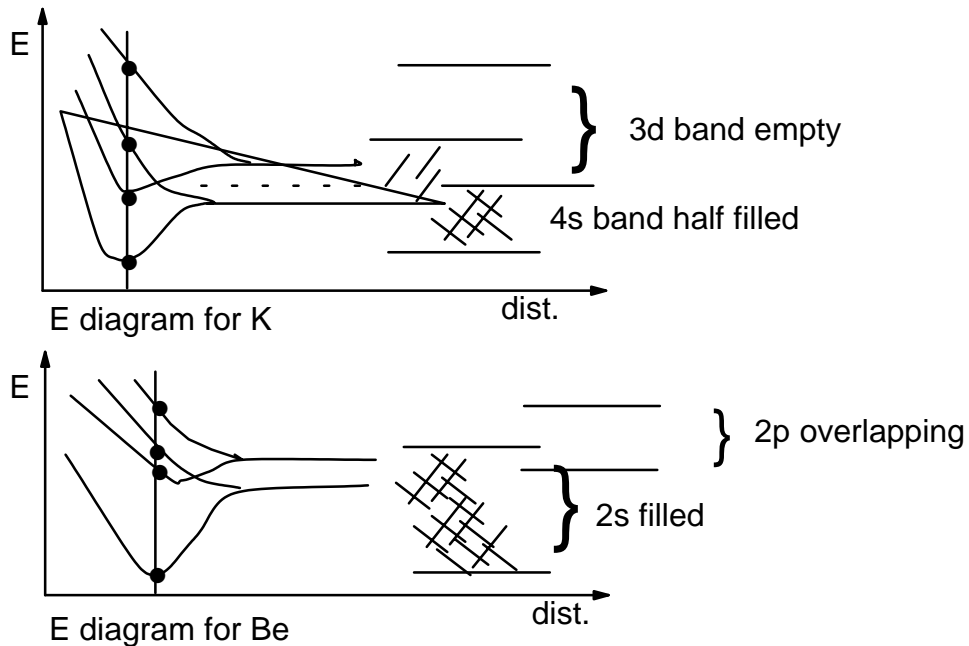

In K, each atom contributes one electron and one orbital to the conduction band (4s band). According to the Pauli exclusion principle, each “molecular orbital” formed in the band (energy state) can accommodate two electrons. As a consequence, the conduction band is only half-filled with electrons – which provides for electrical conduction.

In Be, each atom contributes two electrons and one orbital to the conduction band (2s band). With two electrons per orbital (from each atom) the 2s conduction band is filled. The observed electrical conductivity is due to the overlapping 2p band, which is empty and thus provides empty energy states required for electronic conduction.

9. (a) $E_g = 3.2\text{eV} = 3.2 \times 1.6 \times 10^{-19} \text{ J} = 5.12 \times 10^{-19} \text{ J}$

The full band gap (energy) corresponds to $5.12 \times 10^{-19} \text{ J}$. If we look for the corresponding wavelength of radiation, we have:

$$E = h\nu = \frac{hc}{\lambda} \quad \text{and} \quad \lambda = \frac{hc}{E} = \frac{6.6 \times 10^{-34} \times 3 \times 10^8}{5.12 \times 10^{-19}}$$

$$\lambda = 3.879 \times 10^{-7} \text{ m} = \boxed{3880\text{\AA}}$$

The visible spectrum ranges from 4000–7500Å. Since only radiation with $E \geq E_g$ will be absorbed ($\lambda < 3880\text{\AA}$), the material is transparent to visible light.

9. (b) Most oxide semiconductors are either doped to create extrinsic defects or are annealed under conditions in which they become nonstoichiometric. When ZnO becomes nonstoichiometric, it is commonly because of an excess metal content, for example, $Zn_{1+x}O$. This $Zn_{1+x}O$ is a negative carrier (n-type) oxide conductor and is sometimes called an “excess” semiconductor.
10. (a) [T in thermally activated processes is the absolute temperature – $T^{\circ}K = (273.16 + t^{\circ}C)$; Boltzmann’s constant = $k = 1.38 \times 10^{-23} \text{ J/}^{\circ}K$]

$$T = 293.16K:$$

$$n_i = 9.7 \times 10^{15} \times 293.16^{\frac{3}{2}} \times e^{-\frac{0.72 \times 1.6 \times 10^{-19}}{2 \times 1.38 \times 10^{-23} \times 293.16}}$$

$$= 9.7 \times 10^{15} \times 5019 \times 6.6 \times 10^{-7}$$

$$n_i = 3.21 \times 10^{13}/\text{cm}^3$$

(b) $200^{\circ}C = 473.16K$

$$n_i = 9.7 \times 10^{15} \times 473.16^{\frac{2}{3}} \times e^{-\frac{0.72 \times 1.6 \times 10^{-19}}{2 \times 1.38 \times 10^{-23} \times 473.16}}$$

$$n_i (200K) = 9.7 \times 10^{15} \times 1.03 \times 10^4 \times 1.47 \times 10^{-4}$$

$$n_i = 1.47 \times 10^{16}/\text{cm}^3$$

The number of conducting electrons (in the conduction band) at $200^{\circ}C$ is by about five orders of magnitude less than that of a good conductor. The material will not be a good conductor. (There are additional factors which contribute to the “relatively poor conductivity” of Ge at this temperature.)

11. $E_{th} = \frac{3kT}{2}$ $E_g = 0.72 \times 1.6 \times 10^{-19} \text{ J}$

$$T = \frac{0.72 \times 1.6 \times 10^{-19} \times 2}{3 \times 1.38 \times 10^{-23}} = 5565K = 5.3 \times 10^3 \text{ }^{\circ}C$$

The temperature would have to be $5.3 \times 10^3 \text{ }^{\circ}C$ (about $4400^{\circ}C$ above the melting point).

12. (a) From our limited knowledge of the conduction behavior, we must assume that in semiconductors the conductivity will increase with T since the number of electrons in the conduction band increases.

12. (b) As a first approximation, we can say that the number of free electrons is independent of T ; that, however, the atoms in the lattice will, with increasing temperature, be subject to increased oscillations about their (relatively) fixed position. These oscillations provide greater opportunity for “scattering” of conducting electrons and thus will “reduce” the mobility of the electrons. We can expect the electrical conductivity of metals to decrease with increasing temperature.
13. (a) The optical properties of ZnSe can be explained when comparing the “energy band” of the visible spectrum with the energy band diagram of ZnSe.

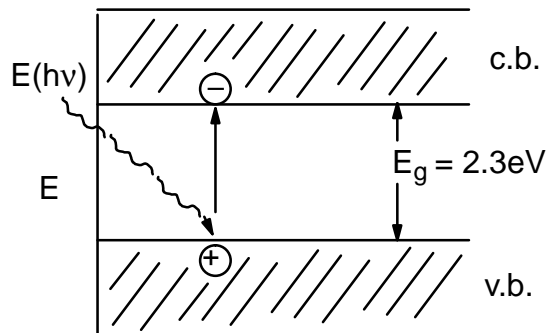

absorption takes place (photo-excitation) for all radiation with $E_{(hv)} \geq 2.3 \text{ eV}$.

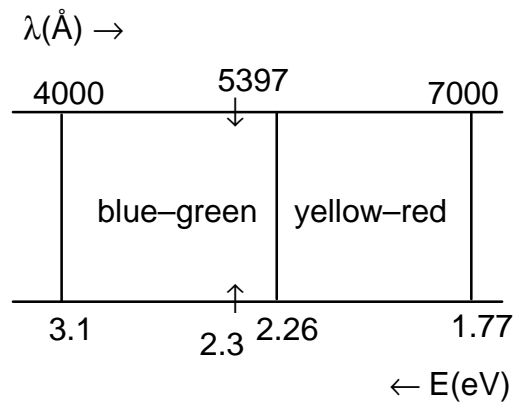

13. (a) Continued.

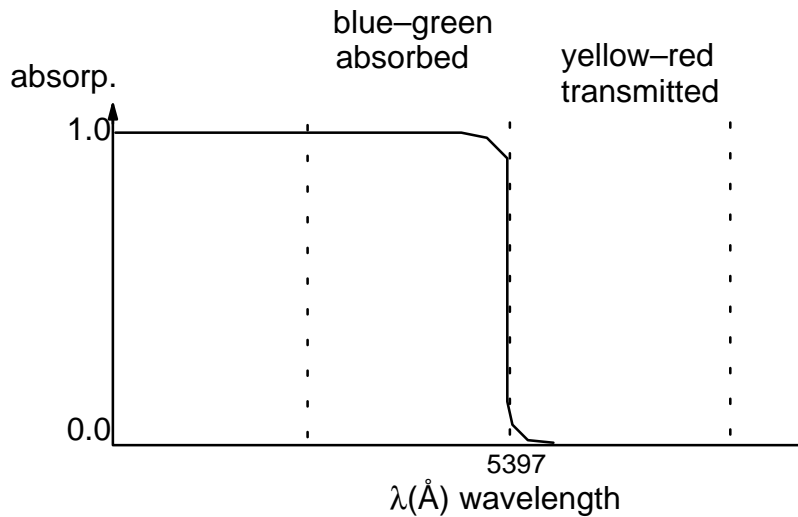

From the energy distribution of the visible spectrum we recognize that the blue-green portion has photon energies in excess of the band gap ($E_g = 2.3\text{eV}$) and thus will be absorbed. The yellow-red portion, on the other hand, has photon energies less than the band gap – it will be transmitted. ZnSe, therefore, is expected to exhibit a yellowish-red color.

(b) In principle there are two ways to increase the electrical conductivity of ZnSe:

- (1) A temperature rise. Any rise in temperature will increase the number of “thermally activated” charge carriers in the conduction band (electrons) and in the valence band (holes) and, thus, the electronic conductivity.

[The electrical conductivity of solids, demonstrated by the flow of electronic charge carriers under an applied electric field (E), can be formulated through Ohm’s law, $J = \sigma E$, which states that the current density (J = number of charges transported through a unit area in a unit time) is proportional (σ = conductivity) to the applied electric field. Accordingly:

$$J = N e \bar{v}_d$$

where N = number of charge carriers/unit volume, e = electronic charge and \bar{v}_d = average drift velocity of charge carriers in an applied electric field. We thus obtain:

$$\sigma = (N e \bar{v}_d)/E$$

13. (b) Continued.

(1) continued –

and if we define $(\bar{v}_d/E) = \mu$, the charge carrier mobility, we have:

$$\sigma = N e \mu$$

In intrinsic semiconductors we have both electrons and holes contributing to conduction:

$$\sigma = N_e e \mu_e + N_h e \mu_h = Ne(\mu_e + \mu_h)$$

since $N_e = N_h$. Taking the number of thermally generated charge carriers, the relationship

$$N = AT^{3/2} \exp^{-E_g/2kT}$$

we obtain the temperature dependence of the conductivity as:

$$\sigma = AT^{3/2} \exp^{-E_g/2kT} \times e(\mu_e + \mu_h)$$

To assess the temperature dependence of electrical conductivity we must take into consideration that, because of increased vibration of the atoms about their lattice positions, the charge carrier mobility will decrease (increased scattering of charge carriers) with increasing temperature. This effect explains why the electronic conductivity in metals, where N is constant, will decrease with increasing temperature. In semiconductors, where N increases with temperature, the accompanying mobility effect is not apparent at low temperatures (conductivity increases), but becomes pronounced at high temperatures (conductivity decreases).]

- (2) Introduction of shallow impurity (or defect) states close to the conduction or valence band. This is accomplished by the incorporation of appropriate dopant elements into the crystal matrix. If these impurities are shallow (~ 0.01 eV from the conduction or valence band), they will be totally ionized at room temperature and each will contribute an electron (donor dopant: K, Na) or holes (acceptor dopant: G, Br), thus increasing the electrical conductivity without the necessity of a temperature rise. (Be aware that certain defects in the crystal lattice may also increase the electronic conductivity.)

14. (a) This crystal is extrinsic of p-type conductivity – i.e. holes in the valence band (majority charge carriers) are primarily responsible for electronic conduction. p-type conductivity results from the fact that the substitutional doping element, boron, has only three valence electrons. Upon incorporation, boron has a tendency to attract an additional electron from the matrix (valence band) to satisfy the bonding requirements (formation of four covalent bonds). In doing so, each boron atom assumes a negative charge (which is not mobile) and simultaneously creates a mobile hole.
- (b) Approach: determine the number of atoms in 28 mg boron and the volume of 100 g silicon.

$$\begin{aligned} \rho \text{ Si} &= 2.33 \text{ g/cm}^3 \\ \text{At.Wt. B} &= 10.81 \text{ g/mole} \\ \text{Volume of 100 g Si} &= (100/2.33) = 42.9 \text{ cm}^3 \end{aligned}$$

$$\# \text{ atoms per 28mg B} = \frac{6.02 \times 10^{23}}{10.81} \times 28 \times 10^{-3} = \boxed{1.56 \times 10^{21}}$$

When incorporated uniformly into a volume of 42.9 cm³ of silicon, the number of boron atoms per cm³ (the number of extrinsic charge carriers – i.e. the number of holes generated) is:

$$\frac{1.56 \times 10^{21}}{42.9} = \boxed{3.6 \times 10^{19}}$$

[It should be specified that this number applies to silicon at room temperature. Assume the temperature were approaching 0 K; then the number of extrinsic charge carriers would approach “zero” since the impurity levels are, by a finite amount (~0.01 eV), above the top of the valence band and the acquired charges will drop back to the lowest possible energy state.]

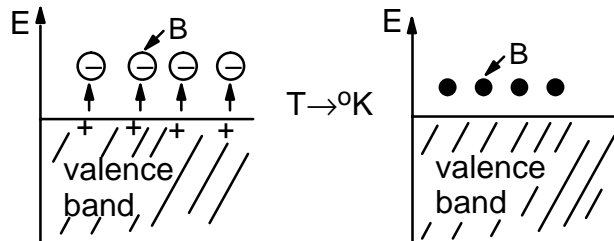

15. "White light" contains radiation in wavelength ranging from about 4000Å (violet) to 7000Å (deep red). A material appearing red in transmission has the following absorption characteristics:

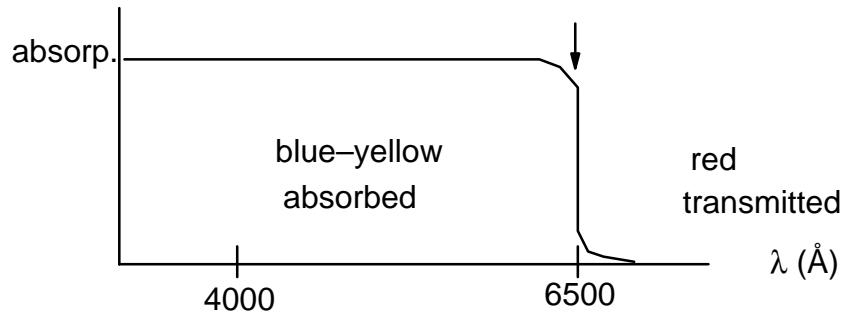

- (a) If the material is pure (no impurity states present), then it must be classified as a semiconductor since it exhibits a finite "band gap" – i.e. to activate charge carriers, photons with energies in excess of "red" radiation are required.
- (b) Taking $\lambda = 6500\text{Å}$ as the optical absorption edge for this material, we have:

$$E_{hv} = \frac{hc}{\lambda} = 3.05 \times 10^{-29} \text{ J} \times \frac{1 \text{ eV}}{1.6 \times 10^{-19} \text{ J}} = \boxed{1.9 \text{ eV}}$$

Accordingly, the band gap for the material is $E_g = 1.9 \text{ eV}$.

16. (a) The antimony-doped Ge is n-type because Sb (with electronic configuration $[\text{Kr}]4d^{10}5s^25p^3$) has five valence electrons, and, therefore, donates one to the Ge ($[\text{Ar}]3d^{10}4s^24p^2$).
- (b) Assume uniform doping of Ge with Sb. Each Sb atom contributes one electron to germanium's conduction band.

$$27 \text{ mg} = \frac{2.7(10^{-2}) \text{ g}}{121.75 \text{ g/mole}} = 2.2(10^{-4}) \text{ mole Sb}$$

So the antimony addition contributes

$$2.2(10^{-4}) \times 6.02(10^{23}) = 1.32(10^{20}) \text{ electrons}$$

16. (b) Continued.

The volume of germanium is:

$$\frac{110 \text{ g}}{5.32 \text{ g/cm}^3} = 20.7 \text{ cm}^3$$

$$n_e = \frac{1.32(10^{20})}{20.7 \text{ cm}^3} = 6.4(10^{18}) \text{ cm}^{-3}$$

17. Need to find E_g :

$$\bar{\nu} = 5.631 \times 10^5 \text{ m}^{-1}$$

$$\lambda = 1/\bar{\nu} = 1.776 \times 10^{-6} \text{ m}$$

$$E_g = (hc)/\lambda = (hc)\bar{\nu} = 0.698 \text{ eV}$$

[Looks like Ge.]

$$T = 250^\circ\text{C} = 523\text{K}$$

$$n_i = AT^{3/2} e^{-E_g/2kT} \text{ cm}^{-3}$$

$$= (5 \times 10^{15}) (523)^{3/2} \exp\left[-\frac{0.698}{2 \times (8.63 \times 10^{-5}) (523)}\right]$$

$$= [5 \times 10^{15}] [1.196 \times 10^4] \exp[-7.688]$$

$$= 2.74 \times 10^{16} \text{ cm}^{-3}$$

18. (a) From the lecture notes you know that a group III element, substitutionally incorporated into silicon, acts as an “acceptor” dopant, and by acquiring electrons from the lattice (valence band) will generate “positive holes” – the crystal will have an excess of (positive) holes – and **it will be p-type**.

18. (b) First we determine the volume of 100g Si, then the number of Al atoms per 33 mg Al and divide this number by the volume of silicon. This gives us the number of Al atoms per cm^3 Si – which is the same as the number of extrinsic charge carriers, since each Al generates one carrier.

$$\text{Vol. Si} = \frac{100 \text{ g}}{2.33 \text{ g/cm}^3} = \boxed{42.9 \text{ cm}^3/100 \text{ g}}$$

33 mg Al contain:

$$\frac{6.02 \times 10^{23} \text{ atoms}}{26.98 \text{ g}} \times 33 \times 10^{-3} \text{ g} = \boxed{7.36 \times 10^{20} \text{ atoms}}$$

$$\begin{aligned} \# \text{ Al atoms per cm}^3 &= \# \text{ charge carriers per cm}^3 \\ &= \frac{7.36 \times 10^{20}}{42.9} = 1.72 \times 10^{19} \text{ Al/cm}^3 \text{ Si} \end{aligned}$$

$$\boxed{= 1.72 \times 10^{19} \text{ extrinsic holes per cm}^3 \text{ Si}}$$

19. Since $E = h\nu$, we find the material to be transparent to photons with energies less than:

$$(6.63 \times 10^{-34} \text{ Js}) \times (1.3 \times 10^{14} \text{ s}^{-1}) \times \frac{1 \text{ eV}}{1.6 \times 10^{-19} \text{ J}} = \boxed{0.54 \text{ eV}}$$

which constitutes the absorption edge, ie the energy band gap.

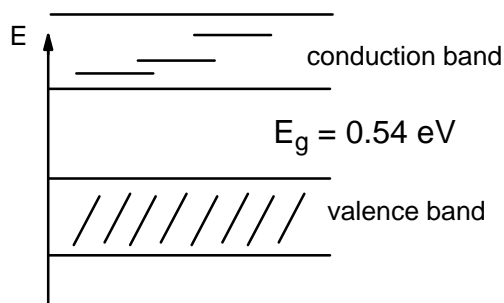

20. (An inadvertent error occurred in the relationship for thermally activated charge carriers. It should be:

$$n_e = AT^{3/2} e^{-E_g/2kT} / \text{cm}^3$$

Also, the dimension of A should be [$\text{cm}^{-3} \times (\text{°K})^{-3/2}$].)

This trivia question therefore has the answer:

$$n_e = 5 \times 10^{15} \times (500 + 273.15)^{3/2} \times e^{-\frac{1.1 \times 1.6 \times 10^{-19}}{2 \times 1.38 \times 10^{-23} \times 773.15}}$$

$$n_e = 5 \times 10^{15} \times 773.15^{3/2} \times e^{-8.25} \text{ cm}^{-3}$$

$$n_e = 2.8 \times 10^{16} \text{ cm}^{-3}$$

21. (a)

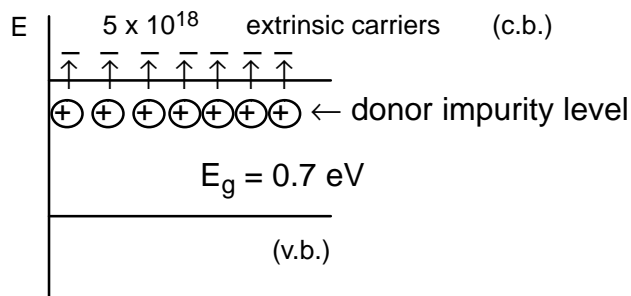

- (b) The band gap of $E_g = 0.7 \text{ eV} \times 1.6 \times 10^{-19} \text{ J} = 1.1 \times 10^{-19} \text{ J}$ corresponds to a cut-off frequency ($E_g = h\nu$):

$$\nu = \frac{1.1 \times 10^{-19}}{6.63 \times 10^{-34}} = 1.66 \times 10^{14} \text{ s}^{-1}$$

The indicated frequency ($1 \times 10^{15} \text{ s}^{-1}$) is higher – the photon energy is larger than E_g . The radiation will be absorbed by germanium and the crystal is opaque to this radiation.

22.

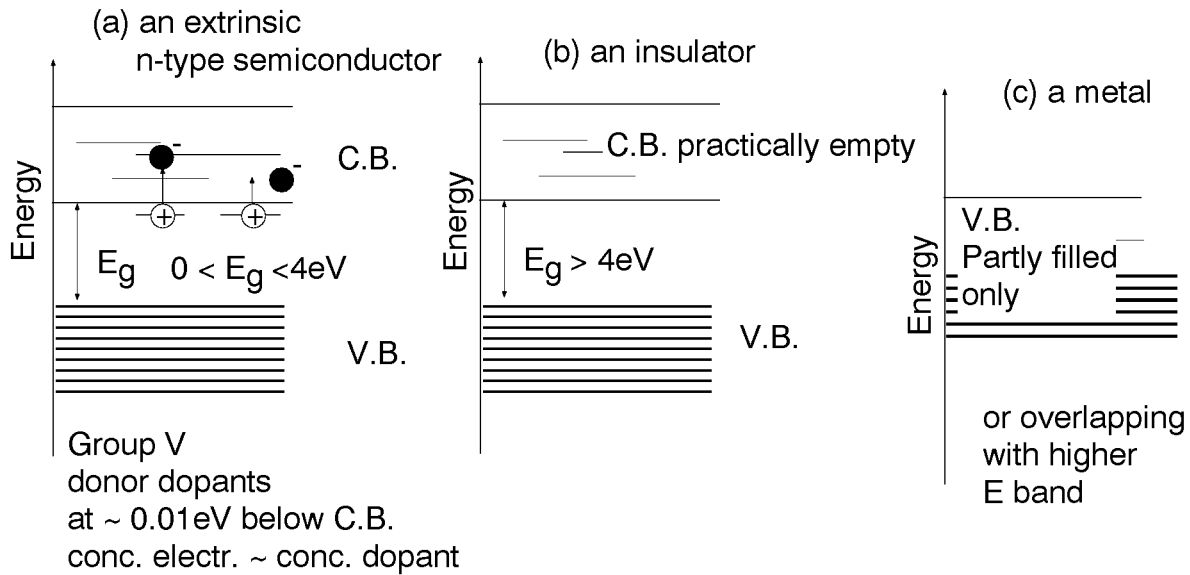

23.

$$E_{\text{photon}} = \frac{hc}{\lambda} = \frac{6.63 \times 10^{-34} \text{Js} \times 3 \times 10^8 \text{m/s}}{300 \text{m}} = 6.63 \times 10^{-38} \text{ J/photon}$$

$$\begin{aligned} \text{The energy of the radio transmitter} &= \text{Power} \times \text{time} \\ &= 50 \times 10^3 \text{ J/s} \times 60 \text{ s} = 3 \times 10^6 \text{ J} \end{aligned}$$

$$\text{Number of photons} = \frac{3 \times 10^6 \text{ J}}{6.63 \times 10^{-28} \text{ J/photon}} = 4.52 \times 10^{33} \text{ photons}$$

$$24. \quad (a) \quad \lambda = \frac{c}{\nu} = \frac{3 \times 10^8 \text{m/s}}{5 \times 10^{14} / \text{s}} = 6 \times 10^{-7} \text{m} = 600 \text{nm}$$

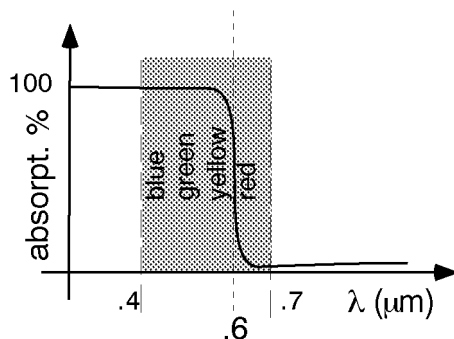

(b) The color will be orange or "reddish".

24. (c) The band gap energy $E_g = E_{\text{photon}} = h\nu$

$$= 6.63 \times 10^{-34} \text{Js} \times 5 \times 10^{14} / \text{s}$$

$$= 3.315 \times 10^{-19} \text{J} \times 1 \text{eV} / 1.6 \times 10^{-19} \text{J}$$

$$= \boxed{2.07 \text{ eV}}$$

25. (Determine the volume of 30g Ge – from that determine the mg of As/cm³ and convert that quantity into # of As atoms (carriers)/cm³.)

$$30 \text{gGe} \times \frac{1 \text{cm}^3}{5.32 \text{g}} = 5.64 \text{cm}^3 ; \frac{5.4 \times 10^{-2} \text{gAs}}{5.64 \text{cm}^3} = \frac{9.57 \times 10^{-3} \text{gAs}}{\text{cm}^3}$$

$$9.57 \times 10^{-3} \text{gAs} \times \frac{6.02 \times 10^{23} \text{atoms}}{74.92 \text{g}} = \boxed{7.69 \times 10^{19} \text{ carriers/cm}^3}$$

26.

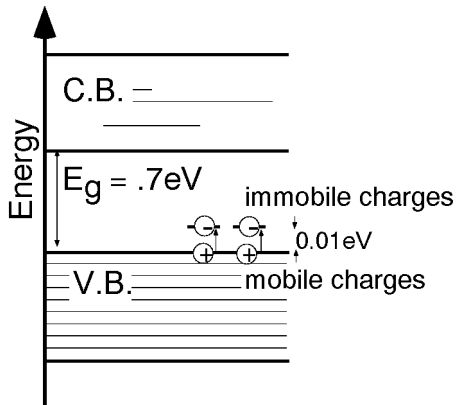

27. (a) $\lambda = \frac{1}{\nu} = \frac{1}{1.613 \times 10^6} \text{m}$
 $= \underline{\underline{0.62 \mu\text{m}}}$

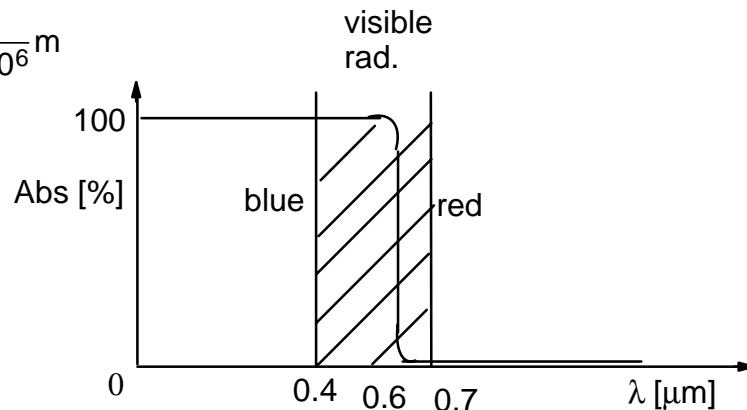

(b) The color will be reddish–orange.

