

DESIGN OF A PROGRAMMABLE OPTICAL SCANNER

by

ANDREW C. FRECHTLING

Submitted in Partial Fulfillment of the
Requirements for the Degree of Bachelor
of Science in Mechanical Engineering

at the

MASSACHUSETTS INSTITUTE OF TECHNOLOGY

June 28, 1976

Signature redacted

Signature of Author.....
Department of Mechanical Engineering, June 28, 1976

Signature redacted

Certified by.....
Thesis Supervisor

Signature redacted

Accepted by.....
Chairman, Departmental Committee on Theses



DESIGN OF A PROGRAMMABLE OPTICAL SCANNER

by

ANDREW C. FRECHTLING

Submitted to the Department of Mechanical Engineering on June 28, 1976, in partial fulfillment of the requirements for the Degree of Bachelor of Science in Mechanical Engineering.

ABSTRACT

To photograph three-dimensional fluid flow, a laser scanning device capable of scanning through 60 points per second is required. A General Scanning G-300PD galvanometer-type scanner, operated under closed-loop control, can achieve the necessary speed of response. The desired scan points are to be pre-programmed as a series of DC voltage inputs, using a step function generator built up of analog and digital elements. The closed-loop controller to be used is the A-603 amplifier, also designed by General Scanning. The complete scanner system will consist of the step function generator, used as a reference signal, and the control circuit, which will drive the scanner.

Thesis Supervisor: C. Forbes Dewey, Jr.

Title: Professor of Mechanical Engineering

ACKNOWLEDGEMENTS

I would like to extend special thanks to Prof. C. Forbes Dewey, who provided the initial idea for this thesis and who has been immensely helpful ever since.

Acknowledgements are also due Dick Fenner and Lon Hocker, who have given me invaluable aid and advice around and about the Fluids Lab.

I would like to thank Ken Yeager, of the Joint Computer Facility, for his guidance through the field of digital electronics.

Prof. Bell, Prof. Wormley, and Prof. Sidall have all been very helpful in discussing problems of control design with me.

To all of the above, I am very grateful ; this thesis truly couldn't have been done without their help.

TABLE OF CONTENTS

Title page.....	1
Abstract.....	2
Acknowledgements.....	3
Table of Contents.....	4
List of Figures.....	5
I. INTRODUCTION.....	6
II. CONTROL STRATEGY.....	7
III. MODEL OF THE SCANNER.....	10
IV. STEP FUNCTION GENERATOR.....	15
V. CONTROL SYSTEM.....	18
VI. RECOMMENDATIONS FOR FURTHER DESIGN.....	19
REFERENCES.....	20
APPENDIX: OPERATION OF THE STEP FUNCTION GENERATOR.....	21
BIBLIOGRAPHY.....	22
FIGURES.....	23

LIST OF FIGURES

Figure # :

- 1) Using a scanning laser to obtain a 3-dimensional image of flow
- 2) Galvanometer scanner set up to scan in the vertical plane.
- 3) Development of a flying scan.
- 4) Open-loop controller.
- 5) Programming via series of step inputs.
- 6) Closed-loop controller.
- 7) Linear graph of a galvanometer model.
- 8) Time response as predicted by ACCESS II.
- 9) Rotating mirror arrangement for observing step response.
- 10) Predicted gain vs, frequency characteristics.
- 11) Observed gain vs. Frequency characteristics.
- 12) Analog section of the step function generator.
- 13) Digital section of the step function generator.
- 14) Step function generator controls.

I. INTRODUCTION

A technique for obtaining photographic images of turbulent flow is available. A stream of water carrying fluorescent dye flows through a transparent tube in the field of a television camera. A longitudinal section of the flow is illuminated by pulsed laser light spread out parallel to the flow direction by a beam spreader. The dye within this illuminated region fluoresces, producing an image of the flow pattern in that particular plane.

With a stationary optical path between the laser and the tube, only one plane in the flow can be imaged. But by moving the beam to points at different levels, a three-dimensional image of the flow pattern can be constructed. If it were possible to scan quickly enough, transient behavior in three dimensions could be seen. The basic idea is shown in Figure 1.

In the stationary, non-scanning, system currently used, the pulse laser strobos at 60 Hz. Therefore, a scanning laser system must move the beam to its next programmed position at sixtieth of a second intervals. This requires a fairly fast scanner.

There are several types of laser scanners available but the galvanometer type was used in this design. Essentially, such a scanner is a galvanometer that rotates a mirror instead of an instrument indicator needle. The changing angle between the stationary incident beam (from the laser) and the rotating

mirror changes the direction of the reflected beam which is sent to the target. See Figure 2. The problem becomes one of obtaining the desired dynamic response of θ , the angle of mirror deflection, so as to have the laser beam at the proper place when the pulse occurs.

II. CONTROL STRATEGY

There are two methods for obtaining the desired scan pattern. One is the flying scan, where the beam is never stationary in space but moves in a continuous motion which passes through the desired scan points at the proper time, i.e. when the laser strobescopes. Figure 3 shows the development of a flying scan pattern. The scanner operates in an open-loop control configuration (Figure 4), which appears to be a simple design in having few elements in the block diagram. There is of course no feedback transducer required in this design. By carefully tailoring the scanner output waveform, it may be possible to get acceptably fast times point-to-point with a low power input. However, there are offsetting disadvantages to this scheme. For every new scan pattern, a new input waveform must be synthesized and this may be difficult to do. The open-loop control system requires some kind of filter or compensator in the forward signal path if the input waveform has Fourier components outside the scanner's own characteristic bandwidth. Finally, and most important, open-loop control is susceptible

to variations with time of the galvanometer's dynamic characteristics. The most noticeable variation is due to magnetic hysteresis induced in the rotating core of the galvanometer (1).

The second approach to system design involves a closed-loop feedback control circuit following step inputs, each of which is a pre-set DC voltage corresponding to the desired value of θ at the steady state. (The steady-state values of θ and the input voltage are related by the steady-state transfer function characteristic of the complete system.) Figure 5 outlines this method of control. The control system may need compensation in the forward path, in the feedback path, or in both; more than one variable may be required for feedback. These elements are shown in Figure 6. The feedback system is optimized for fast response and tries to drive the scanner as quickly as possible to each new position in the programmed series of desired scan points.

There are several advantages to this approach. The input signal is straightforward to generate ; each desired scan point corresponds to one DC voltage. The effects of hysteresis and other unpredictable disturbing and modifying inputs are reduced by feedback.

Generally, a feedback control system will require more power for a given output level than would an open-loop system (2). Another way of looking at this problem is to realize that speeding up the scanner's step response will require increased

power because the acceleration of the moving shaft will be greater. So the input power needed to run the closed-loop system will be greater than that required to run the flying scan system. Another disadvantage of using feedback control is the increased complexity due to the addition of detecting and processing circuitry for obtaining variables to be fed back.

In spite of these two disadvantages, a feedback control system is more versatile and dependable than any open-loop system and thus is recommended for this design. The scanner specified is the General Scanning G-300PD, which incorporates a built-in capacitive position transducer. Theta is therefore available for feedback with this device. (The transducer is excited by a RF voltage from an oscillator, which is also built into the scanner. Thus, the transducer can put out a signal for a steady-state condition, as well as for motion of the galvanometer shaft.) The G-300PD, carrying a 26x26 mm mirror, has been tested by the manufacturer's under closed-loop control and has achieved a response time of less than 5 milliseconds to a fifteen degree step input (3). Output range of the scanner is twenty-five degrees shaft rotation, which gives fifty degrees of optical scanning.

Three developments are necessary for the completion of this programmable scanning system. First, a model of the scanner as a dynamic system in itself is needed for use in control system design. This requires accurate knowledge of the scanner's

dynamic characteristics. Second, a programmable source of step input signals must be designed and tested. Finally, a scanner control circuit, optimized for fast response, is required. These three topics are discussed further in the next sections.

III. MODEL OF THE SCANNER

This model of a galvanometer is based on that presented in Shearer, Murphy and Richardson's text (4). The model consists of a number of discrete ideal linear elements. Its linear graph is presented in Figure 7. Although a galvanometer is a current-to-torque transformer, the model input is a voltage V_s , as it is most convenient to use voltage levels as signals in the control system. There are three energy storage elements present: the coil inductance L ; the inertia of the rotating shaft and mirror, J ; and the elastic spring K . Corresponding state variables are, I , the current through the coil; the rotational velocity of the shaft, ω ; and the torque T_K in the spring. The transducer constant n is defined by Shearer et al.

as:

$$n = - \frac{I}{T} ,$$

but this report uses General Scanning's definition:

$$n = - \frac{T}{I} .$$

The mechanical damping in the system is assumed to be negligibly small.

The system equations in standard matrix form become:

$$(Eqn. 1) \quad \frac{d}{dt} \begin{bmatrix} I_L \\ \omega_J \\ T_K \end{bmatrix} = \begin{bmatrix} -R/L & -n/L & 0 \\ n/J & 0 & -1/J \\ 0 & K & 0 \end{bmatrix} \begin{bmatrix} I_L \\ \omega_J \\ T_K \end{bmatrix} + \begin{bmatrix} 1/L \\ 0 \\ 0 \end{bmatrix} \text{ Vs}$$

In transfer function form the scanner becomes:

$$(Eqn.2) \quad \frac{\theta}{Vs} = \frac{n}{LJs^3 + RJs^2 + (KL+n^2)s + RK}$$

General Scanning provides numerical values for the system parameters seen as constant coefficients in the equations above (5). These are presented below along with the same values expressed in a system of mutually compatible electrical units based on the "practical" (volts-coulombs-joules) system of units.

$$n = 1.4 \times 10^6 \frac{\text{dyne-cm}}{\text{amp}} = .14 \text{ volt-sec}$$

$$(Eqn.3) \quad K = 10^6 \frac{\text{dyne-cm}}{\text{rad}} = .1 \frac{\text{coul-volt}}{\text{rad}}$$

$$R = 10 \text{ ohm}$$

$$J = 7.02 \text{ gm-cm} = 7.02 \times 10^{-7} \text{ coul-volt-sec}^2$$

$$L = .02 \text{ Henry} = .02 \frac{\text{volt-sec}^2}{\text{coul.}}$$

Substitution into Equation 2 gives a numerical expression for the transfer function:

$$(Eqn.4) \quad \frac{\theta}{Vs} = \frac{.14}{1.4 \times 10^{-8} s^3 + 7.02 \times 10^{-6} s^2 + 2.16 \times 10^{-2} s + 1}$$

The characteristic equation of the model scanner is:

$$(Eqn.5) \quad 0 = s^3 + 501.4 s^2 + 1.542 \times 10^6 s + 7.143 \times 10^7 \\ = (s + 46.9)(s^2 + 454.4 s + 1.52 \times 10^6) \\ = (s + 46.9)(s + 227.2 - j1212)(s + 227.2 + j1212)$$

Because the first and zero-order terms are very much larger than the second and third, time response should be similar to that of a first-order system.

To establish the accuracy of the model and that of the numerical values for the system coefficients, both frequency and time response tests are used.

The transient (time response) tests started with an ACCESS II (6) simulation of the response of the scanner model to a 1 volt step input. Results taken from a computer-generated plot of the state variables versus time are shown in Figure 8. As expected from examination of Equation 4, the response looks very similar to that of a first-order system with time constant τ equal to .02 seconds. Steady-state values of the state variables and of θ are:

$$\begin{aligned}
 I_L(\text{steady-state}) &= .1 \text{ amp} \\
 T_K(\text{steady-state}) &= 1.4 \times 10^5 \text{ dyne-cm} \\
 \omega_J(\text{steady-state}) &= 0 \text{ rads/sec.} \\
 \theta(\text{steady-state}) &= .14 \text{ rad}
 \end{aligned}$$

(Eqn.6)

Higher-order effects are seen to disappear from the response curves after one time constant, an effect due to the dominance of the first-order factor in the characteristic equation.

Further transient response tests on the scanner required some means of displaying θ against a time scale. Prof. Dewey suggested the use of a rotating mirror system as shown in Figure 9. Turning at 20 rpm, the mirror "draws" a horizontal time

axis with laser light from a non-pulsed laser. As the scanner deflects in response to an input, the time history of θ is displayed against a screen as in a plot of θ versus time.

Also used in this experiment are a step input source (described in the next section) and a power amplifier with unity voltage gain. A KEPCO ABC 30-.3 power supply running in the voltage programmed mode was used as an amplifier. Frequency response tests on this power supply reveal a roll-off frequency of only 20 Hz., indicative of a first-order system with a time constant of about .008 seconds. This is just about one-third the time constant expected for the scanner itself, so the KEPCO power supply is really too slow to pass "sharp" step inputs to the scanner. A faster DC amplifier should have been used for this step response test, but one was not available.

Photographs of the response trace were not taken. Visual examination of the path of the laser beam across the screen determined the time to reach steady state after a 1 volt step input to be about .12 seconds. This corresponds to the response of a first-order system, of time constant equal to .03-.04 seconds. The increase in time constant over that predicted by the characteristic equation - .02 seconds - may be due mostly to the effect of the slow power amplifier on overall system transfer function.

The frequency response of the G -300PD was also examined. The system transfer function can be re-written in the form:

$$(Eqn.7) \quad \frac{\theta}{V_s} (j\omega) = \frac{K}{(\tau j\omega + 1) \left[\left(\frac{j\omega}{\omega_n} \right)^2 + \left(\frac{2\zeta}{\omega_n} \right) j\omega + 1 \right]}$$

where ζ is a damping ratio and ω_n is a natural frequency.

From the numerical transfer function developed from the manufacturer's data, the roll-off frequency for the first-order term is expected to occur at 46.9 rads/sec (7.4 Hz.). The roll-off for the second-order term is expected at ω_n equal to 1233 rads/sec (196 Hz.). ζ , the damping ratio, can be calculated to be .185. K, the steady-state gain, is .14 rads/volt. Figure 10 shows the predicted frequency response for this transfer function as a Bode plot of gain versus frequency.

Figure 11 shows the observed gain response with changing frequency. (Phase measurements require use of a signal processing circuit for the capacitive position transducer. This circuit has not been built as of this writing.) The experimentally determined values for the coefficient terms in Equation 7 can be found from this Bode plot to be :

$$(Eqn.8) \quad \begin{aligned} K &= .11 \\ \tau &= (37.7 \text{ rads/sec})^{-1} = .026 \text{ sec} \\ \omega_n &= 785 \text{ rads/sec} = 125 \text{ Hz.} \\ \zeta &= .3 \end{aligned}$$

This makes the experimentally determined value of the transfer function :

$$(Eqn.9) \quad \frac{\theta}{V_s} = \frac{.11}{(.026j\omega) \left[\left(\frac{j\omega}{785} \right)^2 + (7.64 \times 10^{-4})j\omega + 1 \right]}$$

It may prove desirable to use this experimentally determined transfer function in control system design, instead of the physical parameters given by the manufacturer's literature. (Equation 3)

IV. STEP FUNCTION GENERATOR

As discussed in Section II, the desired values of θ are to be programmed as a series of DC voltage levels. The change from one level to the next is to be triggered by the flash of light from a pulse laser. This change must occur sufficiently quickly to look like a step input to the control system. The step function generator designed to meet these requirements is a combined analog and digital circuit, shown in Figures 12 and 13.

Figure 12 shows the analog output section of the circuit. Only one of the three variable inputs (0, 1, and 2) is fed into the summing op-amp at any one time. Each input voltage V_{in} is set by a pot (250 ohm) operating between +5V and ground. The fixed -15V input to the op-amp provides a bias so positive output voltages can be produced. As V_{in} goes from +5V to zero, V_{out} goes from its maximum negative value (-4.8V) to its maximum positive value (+4.6V).

The three variable inputs are each enabled in turn through a connection to an open-collector TTL output, labeled "OC" in

Figure 12. Open-collector TTL conducts to ground at logical low (state 0), and does not conduct at all at logical high (state 1). Unlike regular TTL, the output does not pull up towards +5V at the state 1. If only one of the three OC points in Figure 12 is high, only the input signal V_{in} controlled by that particular OC output will be seen by the op-amp's inverting input. Thus, by putting the OC points high sequentially and one at a time, the op-amp's output will be a series of different DC levels, each corresponding to one of the input signals V_{in} .

The rest of the signal generator is designed to control the state of the three OC points. It consists of a positive-logic digital system triggered by either a mechanical switch or a flash of laser light on a photodiode. The MC 1458 type 741 op-amp on the left of Figure 13 produces a positive output when the photodiode is exposed to light and begins conducting. The 100 kilohm pot in the feedback path adjusts the op-amp circuit's sensitivity (ratio of output voltage to light intensity) and the Zener diode limits the output voltage to 4.6V, which is within the TTL high range.

B_1 through B_4 are a 74132 quad Schmitt trigger NAND gate. Gates B_1 and B_2 are in set-reset configuration and serve to debounce the signal from the mechanical SET-RESET switch. B_4 cleans up and inverts the op-amp output, so as the op-amp output rises past the threshold voltage of B_4 , the gate's output goes from high to low. B_3 sends a low state signal to the sequence

counter (C_1 and C_2) when 1) the SET-RESET switch is in set position and the photodiode goes from illuminated to dark, or 2) the laser is off and the SET-RESET switch is cycled from set to reset and back. Note that the counter will advance on the end of the pulse of light from the laser.

The low state signal from B_3 goes to the clock inputs of C_1 and C_2 , which are the two halves of a dual JK flip-flop (74107) that have been connected together to form a modulo 3 counter. This counter has three states:

<u>Counter state</u>	<u>Q1 state</u>	<u>Q2 state</u>
0	low	low
1	high	low
2	low	high

After counting 0-1-2, the counter returns to 0 on the next clock trigger.

Gates D_1 through D_4 make up a 7409 quad open-collector AND gate. When the counter is in state 0, with Q_1 and Q_2 low, D_1 goes high and connects the programmed input $V_{in 0}$ to the summing op-amp in the analog output section. Counter states 1 and 2 cause D_3 and D_2 to go high, respectively. Only one of these three gates is at logical high at any one time, the other two staying low. This insures sequential output of the pre-programmed voltages used as input to the scanner controller. These open-collector gates also drive LED indicators that show the counter state. (D_4 is needed to decode the 0 state and turn on LED 0.)

The step function generator has been built and tested. Output range is +4V to -4V. Slewing time from 0V to 4V is 8 microseconds; that from +4V to -4V is 12 microseconds.

V. CONTROL SYSTEM

The time response tests reveal that the scanner needs a closed loop controller to speed up its response. With a rise time of about .12 seconds, the scanner is limited to only 8 steps/second in open loop operation. Considerable increase in speed of response is necessary to meet the requirement for 60 steps/second operation.

Fortunately, a circuit for closed loop control and power amplification is available from General Scanning as the A-603 type amplifier. This circuit consists of several op-amps (308's and 741's) and a transistorized power amplifier. The output signal from the capacitive position transducer is processed by one op-amp circuit, while the time derivative of this signal is synthesized by another. This means that θ and ω_J are both fed back to the reference point in the loop, because ω_J is simply the derivative of θ . As T_K is related to θ by a constant K, this circuit is seen to involve feedback of two of the three state variables; ω_J and T_K . The input signal range is +10V to -10V with an input impedance of 60 kilohms. A DC power supply of $\pm 12V$ to $\pm 15V$ capable of supplying 1.2 amps is required. The steady-state signal coefficient, or transfer

function, is approximately $.16\text{V/degree}$.

The circuit diagram for the A-603 is available from General Scanning. The same controller, completely assembled with DC power supply, is available in the CCX-100 series, also available from General Scanning.

As mentioned earlier, the manufacturers have used this controller to speed up the response of the scanner to the point where response time is less than 5 milliseconds for a 15 degree step input. This implies a capability for scanning at rates of 200 steps/second.

VI. RECOMMENDATIONS FOR FURTHER DESIGN

To complete the scanning system, the closed-loop controller designed by General Scanning (the A-603) must be built. The output voltage range of the step function generator should be sufficient to obtain the full ± 12.5 degree range of scanner shaft rotation. Once the controller is built, the extent of time response improvement of the controlled scanner can be determined, using the rotating mirror arrangement described in Section III for testing.

If more than three scanning points in the cycle are required a medium-scale integration (MSI) type of digital counter should be used. Such chips as the 7490 (modulo 10) or the 7493 (modulo 16) can be operated so as to count repeatedly any number of steps up to their modulo number.

REFERENCES

- 1) Edward Grenda and Pierre Brosens, "Closing the Loop on Galvo Scanners", Electro-Optical Systems Design, April 1974, pgs. 32-34.
- 2) Chi-Tsong Chen, Analysis and Synthesis of Linear Control Systems : Holt, Rinehart, and Winston Inc., New York, 1975, Chapter 7.
- 3) Brochure on the G-300PD scanner, from General Scanning, 150 Coolidge Ave., Watertown, MA 02172.
- 4) Shearer, Murphy, and Richardson, Introduction to System Dynamics : Addison-Wesley Publishing Co., Reading, Mass., 1967, pgs. 180-186.
- 5) General Scanning, G-300PD brochure.
- 6) ACCESS II computer program is available at the Joint Computer Facility, Rm. 1-111, M.I.T.

APPENDIX : OPERATION OF THE STEP FUNCTION GENERATOR (Figure 14)

1. Connect power supplies (see Figure 14 for diagram) :
 - a) +5V supply : red to +5V, black to ground.
 - b) $\pm 15V$ supply : red to +15V, yellow to ground, black to -15V.
2. Turn on the power supplies. Cycle the SET-RESET switch a couple of times. One and only one LED indicator should be on now.
3. Test the counter by cycling the SET-RESET switch a few more times and watching the sequence of lit LEDs.
4. Hooking up an oscilloscope to the signal output and adjusting the vertical sensitivity to 2V/cm, adjust the three pots in turn to program the desired series of signal voltage levels. Ensure that the LED corresponding to the pot being adjusted is on, indicating that the voltage being adjusted is controlling the generator output.
5. Use the SET-RESET switch to run through a cycle (0-1-2) to confirm that the desired output sequence has been achieved.
6. Adjust the photodiode sensitivity to give reliable triggering of the counter in response to a pulse of laser light. The SET-RESET switch must be in set position for the laser to trigger the counter.

BIBLIOGRAPHY

- 1) C. Alley and K. Atwood, Electronic Engineering, Third Edition : John Wiley and Sons, Inc., New York, 1973.
- 2) Chi-Tsong Chen, Analysis and Synthesis of Linear Control Systems : Holt, Rinehart, and Winston, Inc., New York, 1975.
- 3) Ernest Doebelin, Measurement Systems : McGraw-Hill Book Co., New York, 1975.
- 4) Jerald Graeme, Applications of Operational Amplifiers - Third-Generation Techniques : Burr-Brown Research Corp., McGraw Hill Book Co., New York, 1973.
- 5) Walter Jung, IC Op-amp Cookbook, : Howard W. Sams & Co., Inc., Indianapolis, Ind., 1974.
- 6) Don Lancaster, TTL Cookbook : Howard W. Sams & Co., Inc., Indianapolis, Ind., 1974.
- 7) Katsuhiko Ogata, Modern Control Engineering : Prentice-Hall, Inc., Englewood Cliffs, NJ, 1970.
- 8) Shearer, Murphy and Richardson, Introduction to System Dynamics : Addison-Wesley Publishing Co., Reading, Mass., 1971.
- 9) Brochures on the CCX-100 series and A-603 amplifier, and on the G-300PD scanner, were obtained from General Scanning, 150 Coolidge Ave., Watertown, MA 02172.

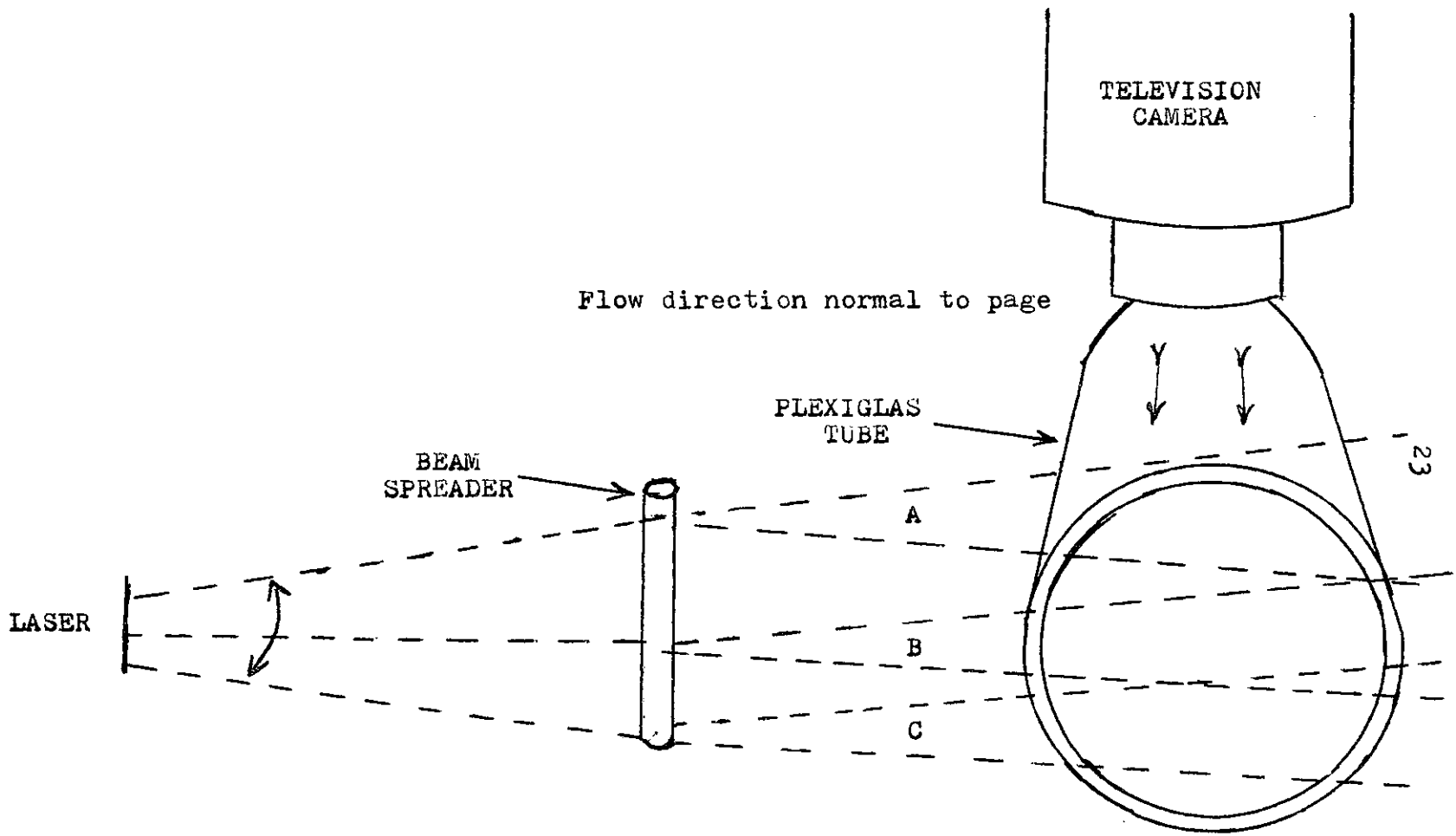

Figure 1: A 3-dimensional image of the flow can be obtained by examining the flow patterns in planes A,B,C, as photographed by the TV camera. The laser beam is scanned between A,B, and C through a beam spreader to produce three planes of illuminated fluid.

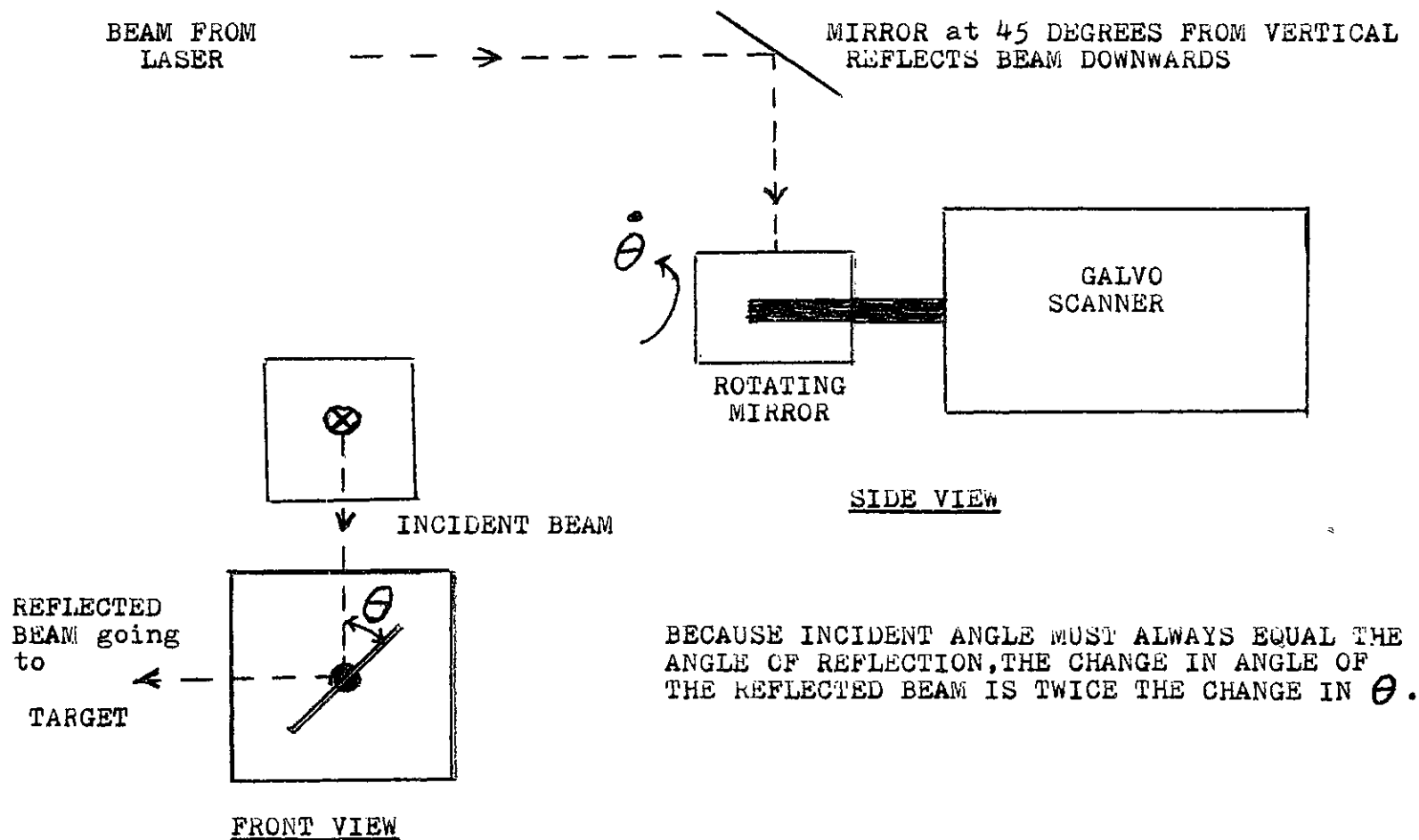

Figure 2: Galvanometer scanner set up to scan in the vertical plane with a horizontal beam coming from a laser.

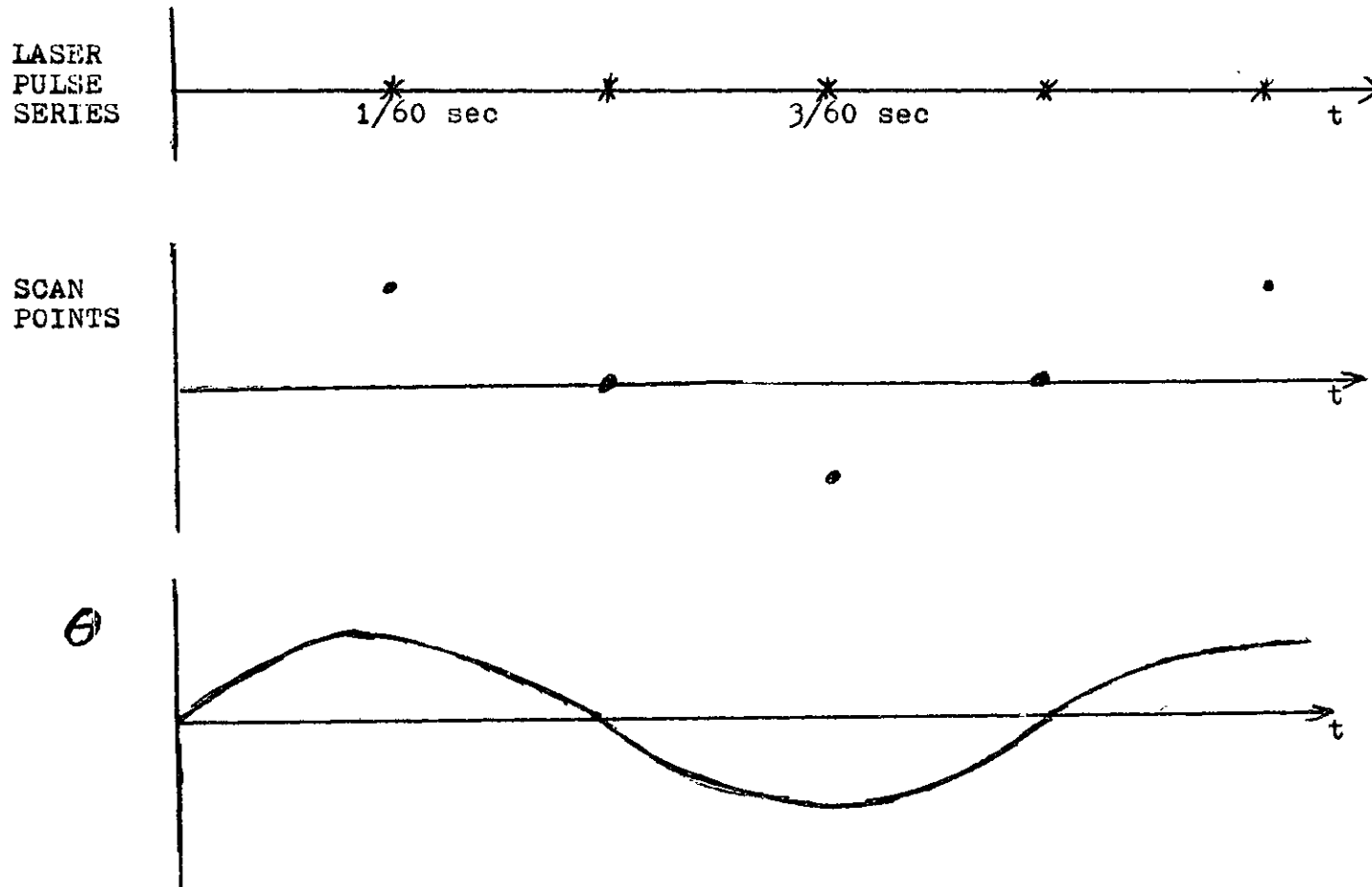
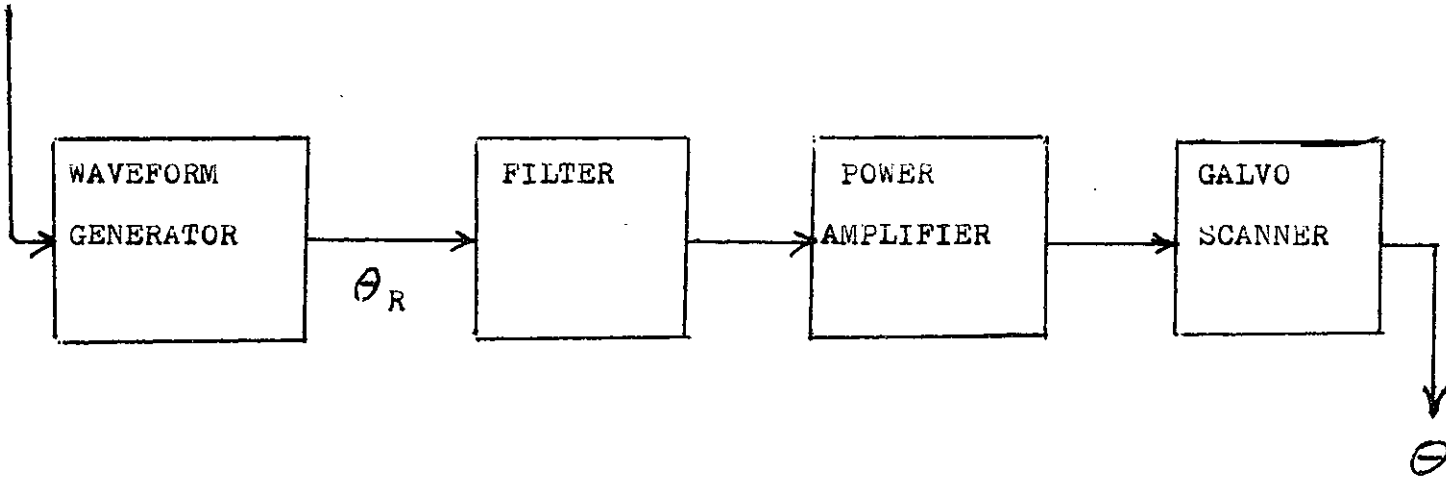

Figure 3 : A flying scan waveform for θ is developed by knowing the time and displacement values of the desired scan points, then getting a smooth waveform to fit.

DESIRED θ vs. TIME SEQUENCE



26

Figure 4 : An open-loop control system tries to follow reference signal θ_R without using feedback.

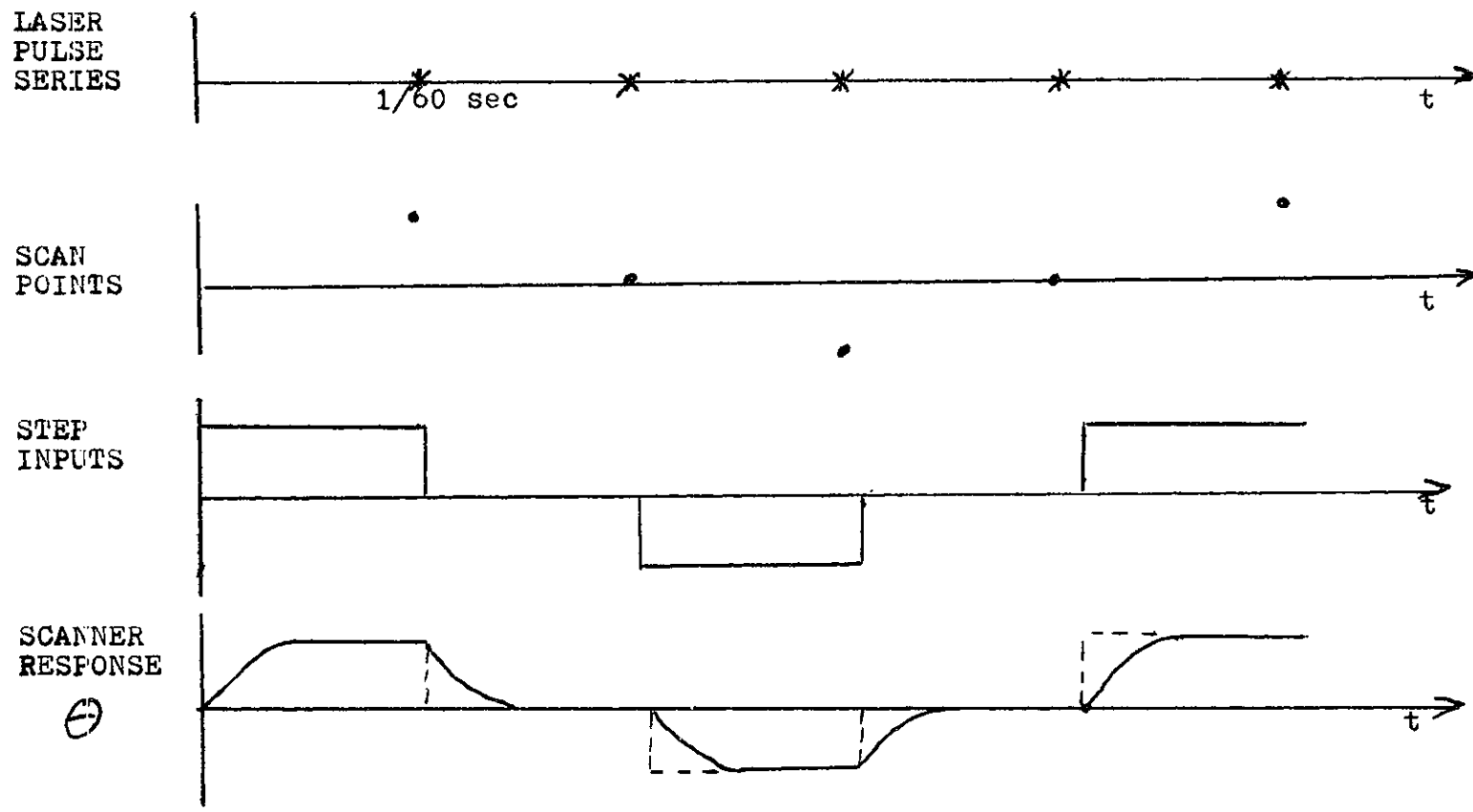

Figure 5 : Use of a series of step functions can give acceptable programming if the scanner can follow to steady-state within 1/60 second.

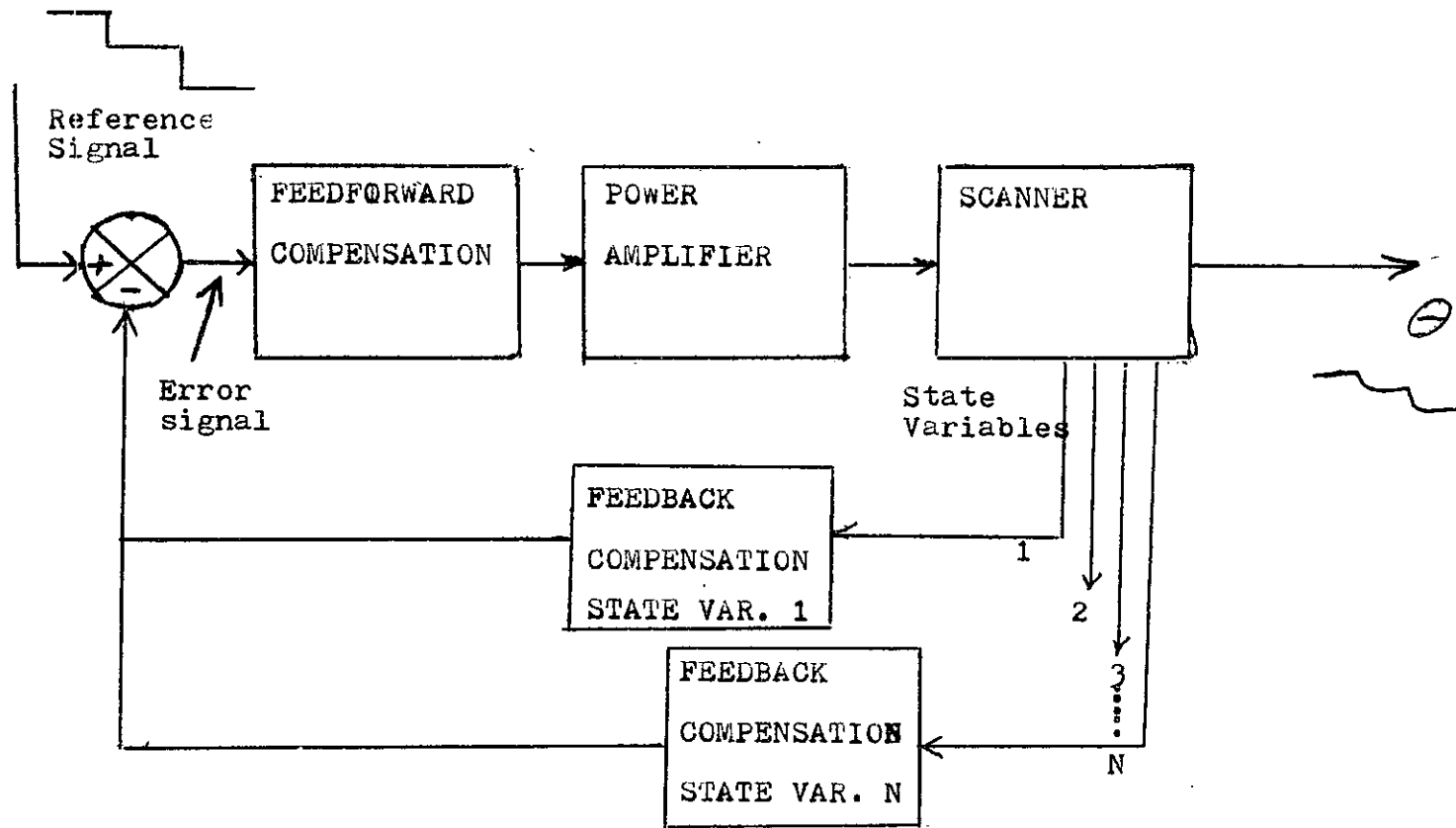

Figure 6 : Several elements are required for closed-loop control, depending on final design, Control is always based on the generation of an error signal between the fed-back state variables and the reference signal.

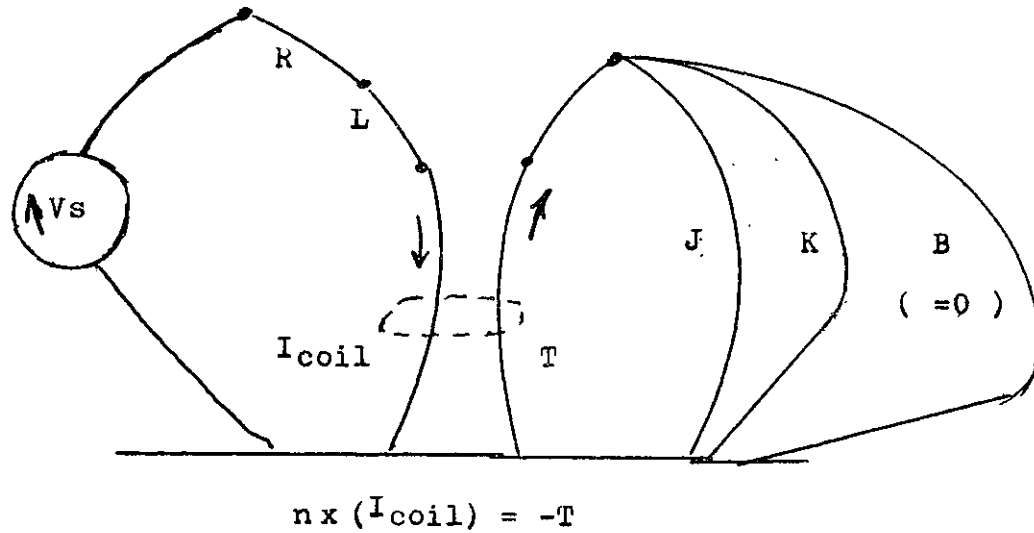

Figure 7 : Linear graph of a galvanometer, based on Reference (4).
 The mechanical damping B is assumed to be negligibly small.

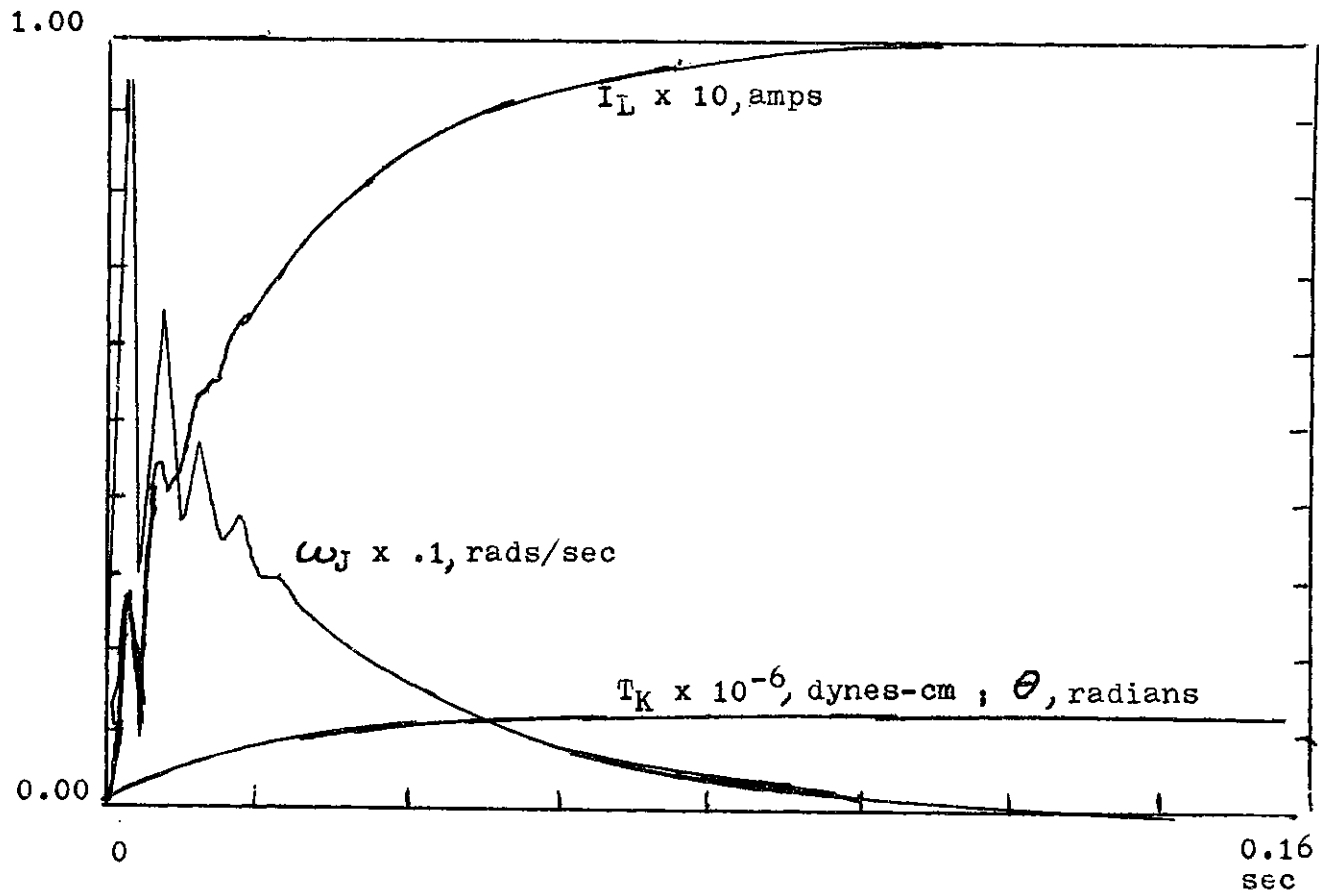

Figure 8 : ACCESS II -generated plot of the response of system described by Eqn. 1 ,with a 1 volt step input. Note that T_K and θ are related by a constant($K= 10^6$ dyne-cm/radian),so they share a response curve.

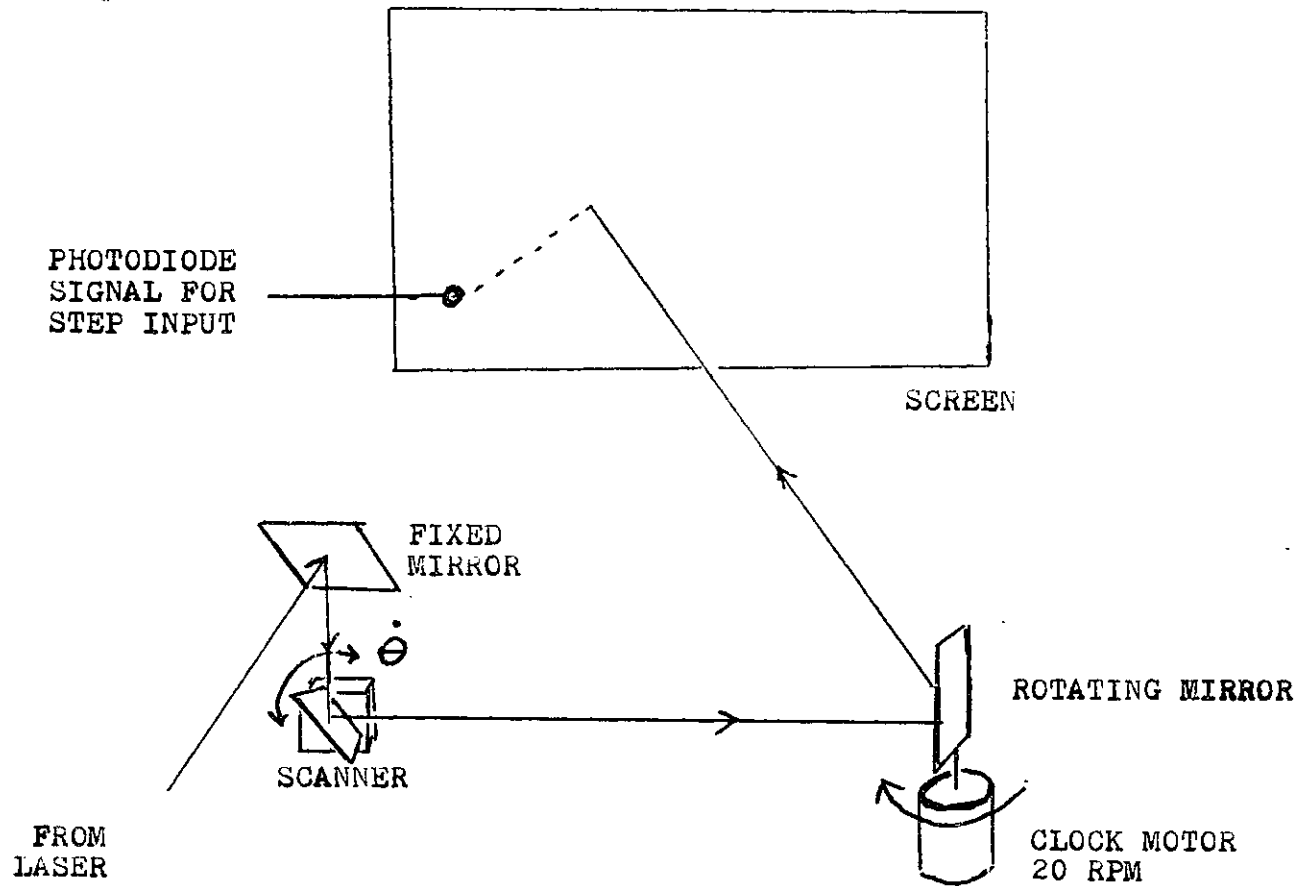

Figure 9 : Use of a rotating mirror arrangement to observe scanner step response. With a constant rate of rotation, the time scale at the screen (number of seconds/inch) is just a function of the distance from the mirror to the screen. A step voltage input to the scanner is triggered by the photodiode at the edge of the screen.

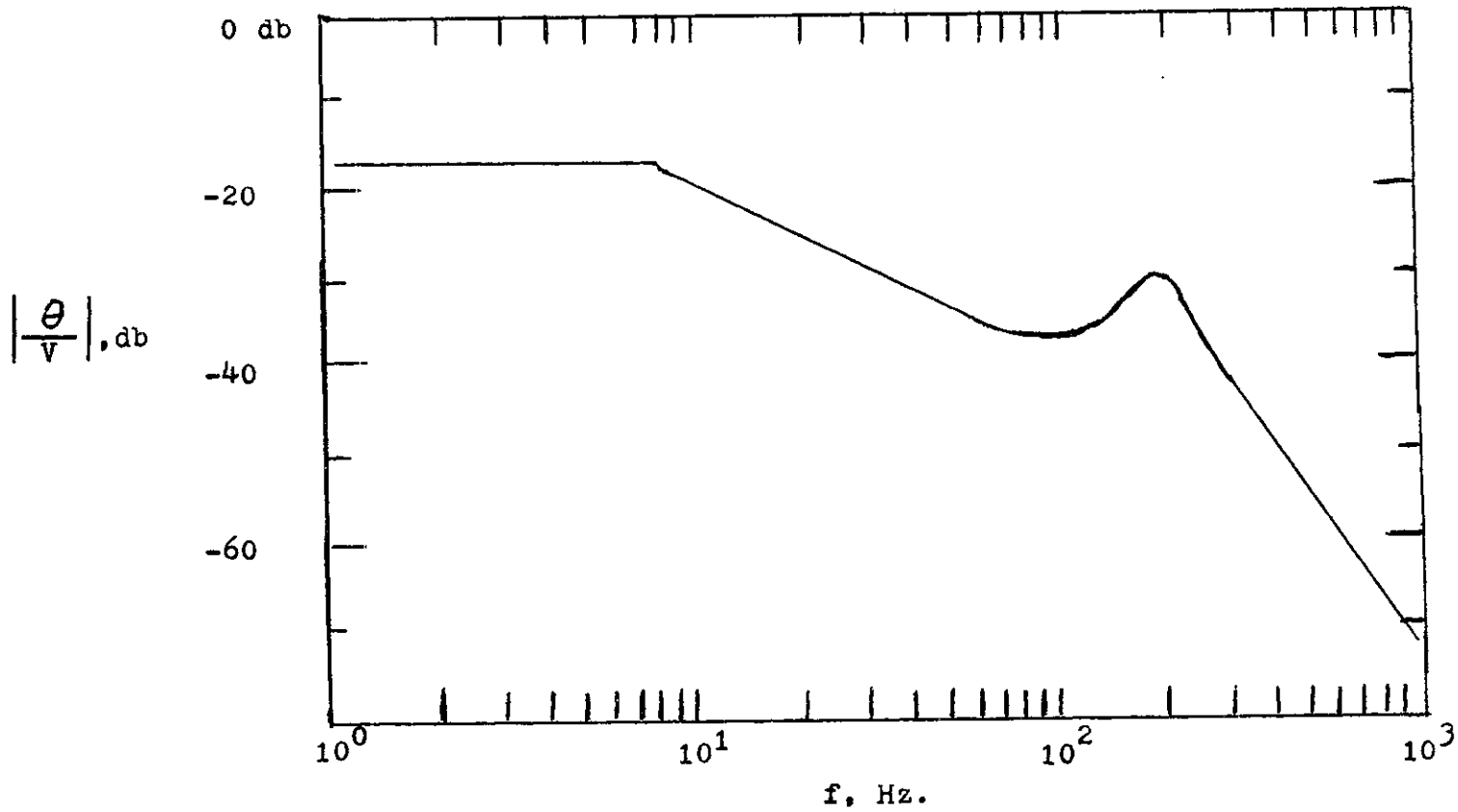

Figure 10 : Gain vs. frequency curve for the transfer function of Eqn.7, the predicted transfer function for the G-300PD scanner based on manufacturer's data.

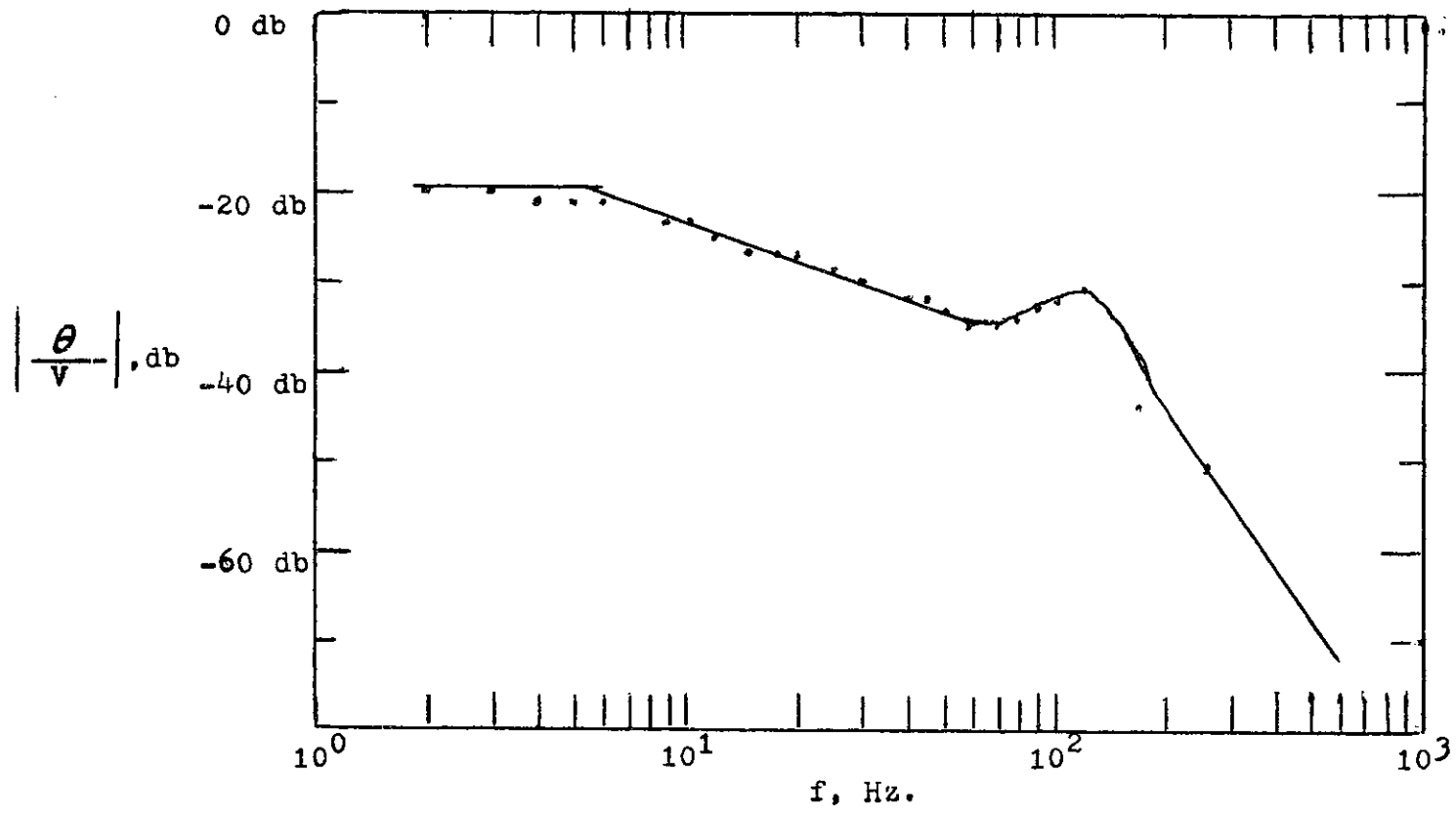
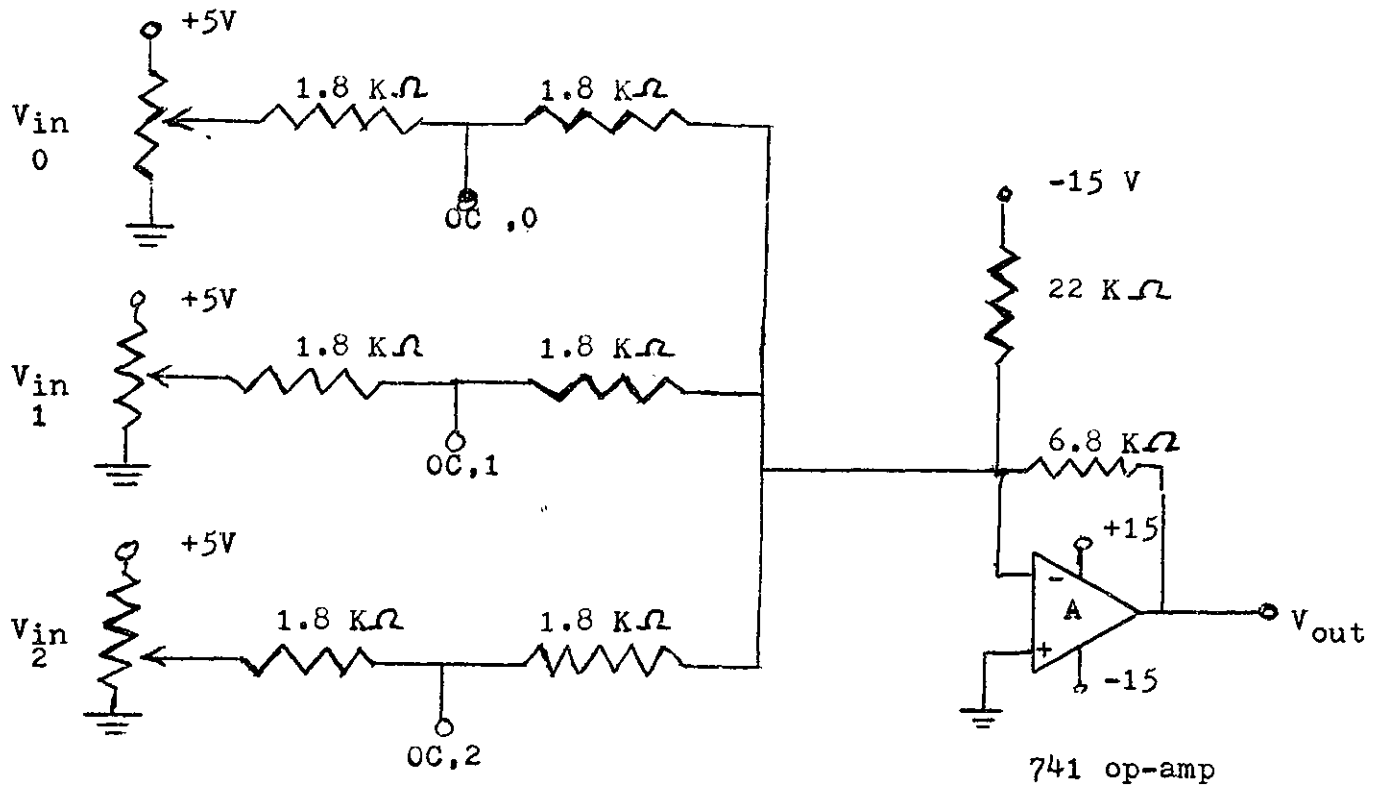

Figure 11 : Observed gain vs. frequency response for the G-300PD scanner.



34

Figure 12 : Analog output section of the step function generator. V_{in} 's are programmed voltage levels, The logical state of the points labelled "OC" controls which V_{in} is enabled to send its signal to the summing point.

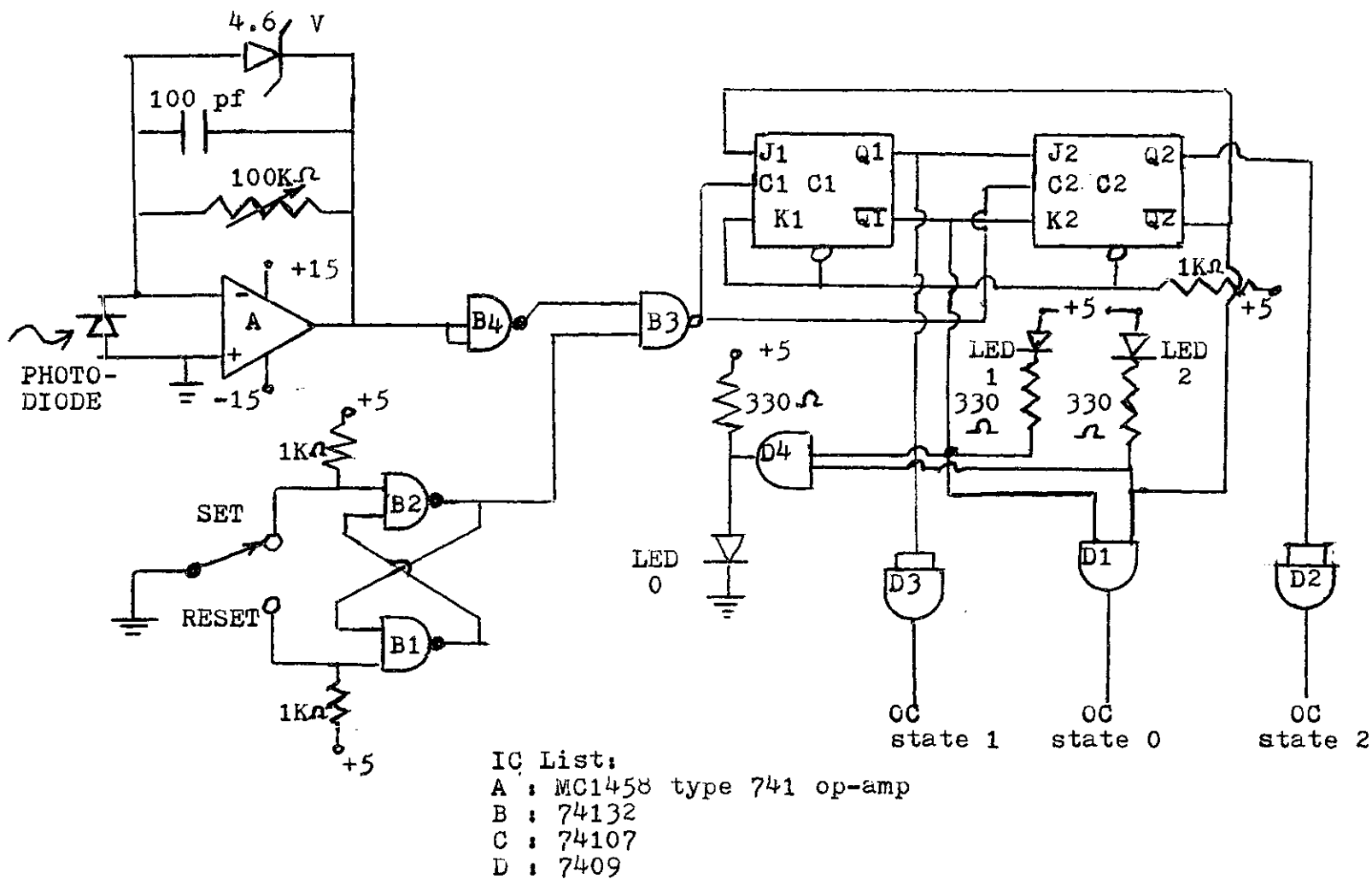

Figure 13 : The digital section of the step function generator. The circuit connects with that part shown in Fig. 12 at points labelled "OC state ___".

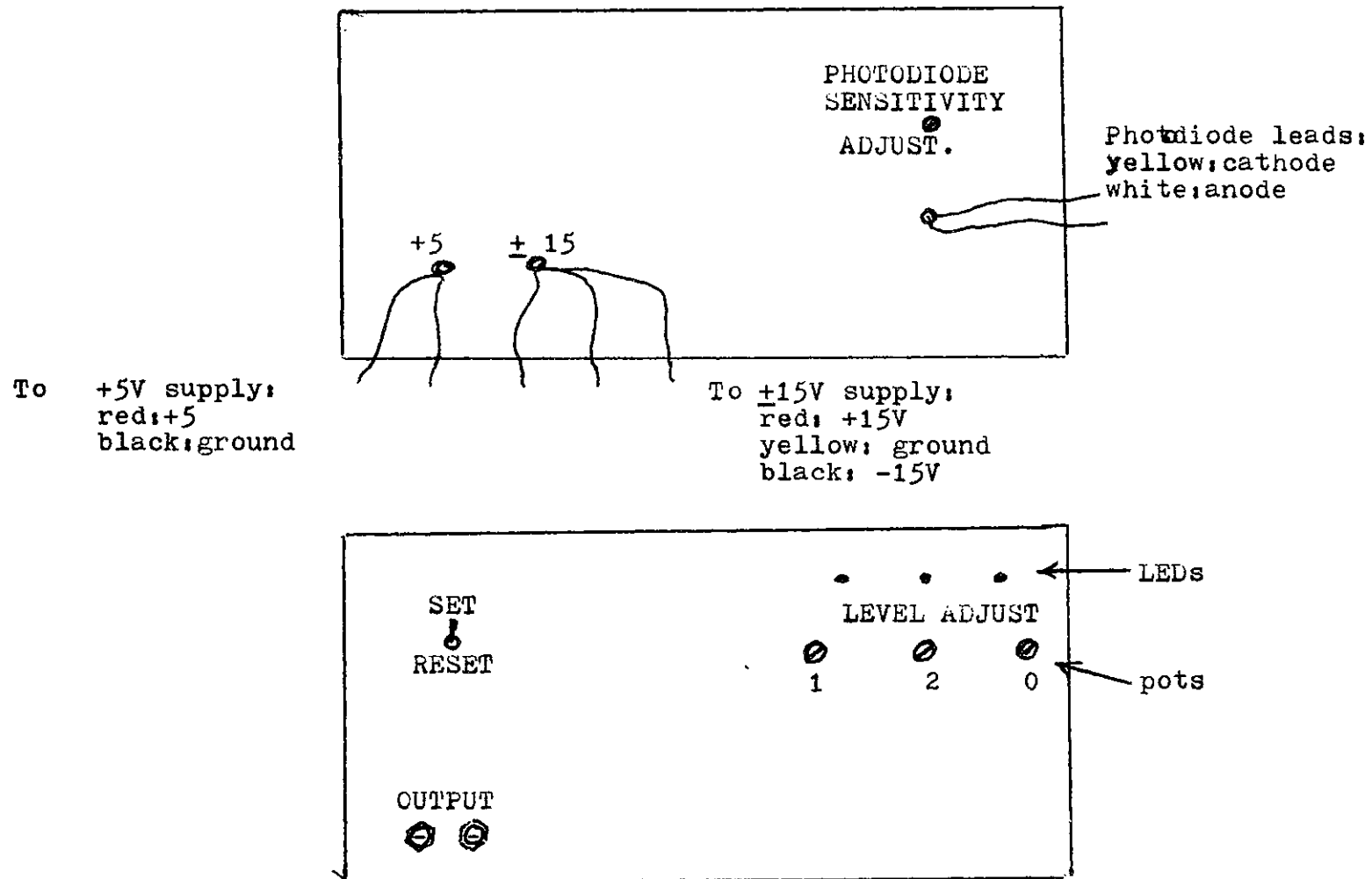

Figure 14 : Controls for the step function generator.