

R90-14

TC171
.M41
.H99
no. 331



CHEMICALLY ENHANCED WASTEWATER TREATMENT



by
SHAWN P. MORRISSEY
and
DONALD R. F. HARLEMAN

RALPH M. PARSONS LABORATORY
AQUATIC SCIENCE AND ENVIRONMENTAL ENGINEERING

Report Number 331

Prepared under the support of
MIT's School of Engineering and Department of Civil Engineering

The Ralph M. Parsons Laboratory Technical Report Series
is supported in part by a grant from the Ralph M. Parsons Foundation

September, 1990

BARKER ENGINEERING LIBRARY

MIT

DEPARTMENT
OF
CIVIL
ENGINEERING

SCHOOL OF ENGINEERING
MASSACHUSETTS INSTITUTE OF TECHNOLOGY
Cambridge, Massachusetts 02139

R90-14

CHEMICALLY-ENHANCED WASTEWATER TREATMENT

by

Shawn P. Morrissey - Research Assistant
Donald R.F. Harleman - Ford Professor of Engineering

RALPH M. PARSONS LABORATORY
AQUATIC SCIENCE AND ENVIRONMENTAL ENGINEERING

Report Number 331

Prepared under the support of
MIT's School of Engineering and Department of Civil Engineering

September 1990

CHEMICALLY-ENHANCED WASTEWATER TREATMENT

ABSTRACT

Many municipalities are currently under court order to provide secondary-level treatment to their wastewater. Since federal funding is no longer available to build the necessary facilities, the burden of paying for secondary treatment is on the rate-payers. Traditionally, conventional primary treatment followed by a biological process has been used to obtain secondary levels of treatment; however, the capital and operations and maintenance costs for this type of treatment are high. Chemically-enhanced wastewater treatment is a lower-cost alternative.

Both jar and full-scale tests using chemicals and polymers have been conducted at South Essex Sewerage District (SESD) to determine the effects of chemically-enhanced wastewater treatment. SESD's plant is unique in that it can be run as two distinct, parallel, and simultaneous processes. This allowed a direct comparison between chemical treatment and conventional primary treatment.

The test results indicate a significant improvement in the removal of total suspended solids, biochemical oxygen demand, phosphorus, and fats, oils, and greases without a large accumulation of sludge. The chemically-enhanced wastewater treatment process is extremely promising in terms of reducing the size of any additional treatment facilities needed to meet secondary levels, increasing the performance of overloaded clarifiers, and as a viable alternative to biological secondary treatment especially in environments where nutrient removal is more of a concern than BOD effluent concentrations (such as in the ocean).

ACKNOWLEDGEMENTS

The author would like to thank the following people for their assistance in compiling information on existing treatment facilities using chemicals to treat wastewater: Y.J. Shao at the Hyperion plant in the City of Los Angeles; Blair Hanson and Jim Stahl at the JWPCP plant in Los Angeles County; Greg Pamson and Blake Anderson at the Orange County Sanitation District; Walter Konopka, Alan Langworthy, Eric Meische, and Susan Hamilton of the Clean Water Program in San Diego; Pierre Purenne at the Montreal Urban Communities Treatment Plant; Jack Burns of the City of Sarnia Treatment Plant; Paul Sagberg of the VEAS treatment plant in Norway.

Thanks go to Jerry Hinson and Pete Bixler of Delta Chemicals Inc for sharing their knowledge and resources; Bill Liss of SESD for the chemical analyses; Andy Sims, Hal Newhall, Randy Briggs, and the rest of the SESD staff for their cooperation in providing data and technical assistance throughout the full-scale testing.

Thanks also go to Professor Donald R.F. Harleman for his support and willingness to share of himself and his knowledge.

Special thanks go to Maria, my wife, for her help with this document and her undaunted support throughout our life together. Without her this would not have been possible.

Funding for this research has been provided by MIT's School of Engineering and the Department of Civil Engineering.

TABLE OF CONTENTS

Abstract		2
Acknowledgements		3
Table of Contents		4
List of Figures		7
List of Tables		10
Chapter 1	Introduction to Chemically-Enhanced Wastewater Treatment	12
	1.1 Introduction	12
	1.2 History	16
	1.3 Comparison of Treatment Processes	18
	1.4 Coagulation and Flocculation	18
	1.4.1 Coagulation (Particle Destabilization)	22
	1.4.2 Flocculation (Particle Transport)	24
	1.5 Chemicals	27
	1.5.1 Natural Organic Compounds	27
	1.5.1.1 Alum	28
	1.5.1.2 Lime	28
	1.5.1.3 Ferric Chloride	29
	1.5.1.4 Seawater	29
	1.5.2 Synthetic Organic Polyelectrolytes (Polymers)	31
Chapter 2	Review of Existing Chemically-Enhanced Treatment Plants	34
	2.1 Introduction	34
	2.2 United States and Canadian Plants	34
	2.2.1 Point Loma - The City of San Diego, California	35
	2.2.2 County Sanitation District - Orange County, California	39
	2.2.3 JWPCP - Los Angeles County, California	43
	2.2.4 Hyperion - The City of Los Angeles, California	46
	2.2.5 North End Plant - Tacoma, Washington	50
	2.2.6 Sarnia Treatment Plant - Sarnia, Ontario Canada	50
	2.2.6 Montreal Urban Community Wastewater Treatment Plant - Montreal, Quebec Canada	55
	2.3 Scandinavian Plants	58

Chapter 3	Chemical Addition at South Essex Sewerage District (SESD) Primary Treatment Plant: A Case Study	64
	3.1 Introduction	64
	3.1.1 Description of SESD's Primary Treatment Plant	65
	3.1.2 Tests Conducted at SESD	73
	3.2 Jar Test Studies	73
	3.2.1 Jar Testing by Delta Chemical, Inc.	74
	3.2.2 Jar Testing by Tighe & Bond, Inc.	80
	3.2.3 Discussion of Jar Testing at SESD	85
	3.3 Full Scale Tests	85
	3.3.1 Full Scale Test #1 (December 18-19, 1989)	87
	3.3.2 Full Scale Test #2 (January 3-4, 1989)	89
	3.3.3 Full Scale Test #3 (January 22-26, 1990)	92
	3.3.3.1 Conclusions From Full Scale Test #3	94
	3.3.4 Full Scale Test #4 (March 25 - April 15, 1990)	95
	3.3.4.1 Conclusions From Full Scale Test #4	99
	3.3.4.2 Discussion of Full Scale Test #4	100
	3.3.5 Discussion of Full Scale Testing at SESD	104
	3.3.5.1 Hydrodynamics	104
	3.3.5.2 Chemical Mixing, Contact Time, and Location	105
	3.3.5.3 Electrical Charge	106
	3.3.6 Recommendations For Future Chemically-Enhanced Testing at SESD	106
Chapter 4	Discussion	108
	4.1 Introduction	108
	4.2 Overflow Rate	108
	4.3 Biochemical Oxidation Rate	113
	4.4 Advanced Primary Treatment	115
	4.4.1 Advanced Primary Treatment followed by an Activated Sludge Process	116
	4.4.2 Advanced Primary Treatment followed by a Trickling Filters Process	118
	4.5 Chemical Secondary Treatment	123
	4.5.1 Chemical Concentration	123

4.6	Sludge	126
4.6.1	Sludge Production	126
4.6.2	Sludge Processing	128
4.6.2.1	Solids Content	128
4.6.2.2	Sludge Conditioning	130
4.6.2.3	Digestion	131
4.6.2.4	Dewatering	132
4.6.3	Sludge Disposal	133
4.6.3.1	Land Disposal of Sludge	133
4.7	Costs Associated With Chemically-Enhanced Wastewater Treatment	136
4.7.1	O&M Costs	136
4.7.2	Capital Costs	140
4.7.3	Cost of Processing Sludge	140
4.8	Concluding Remarks	142
	References	144

LIST OF FIGURES

Figure 1.1:	Various Chemical Treatment Processes (Harleman and Morrissey, 1990)	14
Figure 1.2:	Distribution of Particle Sizes Removed by Different Treatment Processes (Levine, et al., 1985)	21
Figure 1.3:	Schematic Representation of Interparticle Bridging as Can Occur in the Coagulation of Colloids With Polymers (O'Melia, 1970)	23
Figure 1.4:	Schematic Relationship Between Flocculation Performance and Flocculation Variables (Odegaard, 1989)	26
Figure 1.5:	Relationship Between Lime Concentration and Alkalinity (Culp, et al., 1978)	30
Figure 1.6:	Schematic of a Cationic Polymer	31
Figure 1.7:	Acrylamide Monomer and Polymer (Klass, et al., 1975)	32
Figure 1.8:	Anionic and Cationic Polyacrylamides (Klass, et al., 1975)	32
Figure 2.1:	Site Plan of the Point Loma Primary Wastewater Treatment Plant (Konopka, 1989)	36
Figure 2.2:	Flow Diagram of the Point Loma Primary Wastewater Treatment Plant	37
Figure 2.3:	Process Diagram of Orange County Sanitation District's Treatment Plants Number 1 and 2 (Pamson, 1989)	40
Figure 2.4:	Flow Diagram of the Orange County Sanitation District's Treatment Plant Number 1	41
Figure 2.5:	Flow Diagram of the Orange County Sanitation District's Treatment Plant Number 2	42
Figure 2.6:	Process Diagram of the Joint Water Pollution Control Plant, Los Angeles County (Hanson, 1989)	44
Figure 2.7:	Flow Diagram of the Joint Water Pollution Control Plant, Los Angeles County	45
Figure 2.8:	Process Diagram of the Hyperion Wastewater Plant, City of Los Angeles (Shao, 1989)	47
Figure 2.9:	Flow Diagram of the Hyperion Wastewater Plant, City of Los Angeles	48
Figure 2.10:	Site Plan of the North End Treatment Plant, Tacoma, Washington (Capestany, 1989)	51
Figure 2.11:	Flow Diagram of the North End Treatment Plant, Tacoma, Washington	52
Figure 2.12:	Site Plan of the Sarnia Treatment Plant (Burns, 1989)	53

Figure 2.13:	Flow Diagram of the Sarnia Treatment Plant	54
Figure 2.14:	Process Diagram of the Montreal Urban Community Treatment Plant (Purene, 1989)	56
Figure 2.15:	Flow Diagram of the Montreal Urban Community Treatment Plant	57
Figure 2.16:	Various Scandinavian Chemical Treatment Processes	59
Figure 2.17:	Process Diagram of the Oslo Treatment Plant (Sagberg, 1989)	61
Figure 2.18:	Flow Diagram of the Oslo Treatment Plant	62
Figure 3.1:	Location of the South Essex Sewerage District (CDM, 1986)	66
Figure 3.2:	Site Location of the SESD Facility (CDM, 1986)	67
Figure 3.3:	Process Diagram for SESD	68
Figure 3.4:	Liquid Process Diagram for SESD (Tighe & Bond, June, 1990)	70
Figure 3.5:	TSS and BOD ₅ Removal Rates for Various Cationic Polymers	77
Figure 3.6:	TSS and BOD ₅ Removal Rates for Various Anionic Polymer Concentrations	79
Figure 3.7:	TSS and BOD ₅ Removal Rates at SESD for Three Different Manufacturers	84
Figure 3.8:	A Plan View Schematic of the SESD Treatment Facility (Test #1)	87
Figure 3.9:	A Plan View Schematic of the SESD Treatment Facility (Test #2)	90
Figure 3.10:	Schematic of SESD's Treatment Plant, Treated Side Only (Test #3)	93
Figure 3.11:	Schematic of SESD's Treatment Plant Showing Location of Chemical Injection for Scenario 1 (March 25 - April 9)	97
Figure 3.12:	Schematic of SESD's Treatment Plant Showing Location of Chemical Injection for Scenario 1 (April 9 - April 12)	97
Figure 3.13:	Schematic of SESD's Treatment Plant Showing Location of Chemical Injection for Scenario 1 (April 12 - April 16)	97
Figure 3.14:	Comparison of TSS Effluent Samples Analyzed by Different Samplers at SESD	101
Figure 3.15:	Streaming Current Reading for Each Day Overlaid on Treated TSS Concentration for Each Day	103
Figure 4.1:	Design Overflow Rate for TSS and BOD ₅ Removals in Primary Clarifiers (WPCF, 1985)	110
Figure 4.2:	Overflow Rate for TSS and BOD ₅ Removals for Existing Chemically- Enhanced Treatment Facilities	111
Figure 4.3:	Overflow Rate Verses TSS Removal for Sarnia Treatment Plant (Hienke, et al. 1983)	112

Figure 4.4:	Overflow Rate verses BOD ₅ Removal for SESD During Chemical Testing From March 25 1990 Through April 16, 1990 (Morrissey and Harleman, May, 1990)	114
Figure 4.5:	Cross Section of a Trickling Filter (Benefield and Randall, 1980)	119
Figure 4.6:	Comparison of Volume Requirements for Trickling Filters and Activated Sludge Systems Based on Various Incoming BOD ₅ Concentrations	122
Figure 4.7:	Amount of Alum Required to Remove Phosphorus	125
Figure 4.8:	Energy Consumption Required for Biological Treatment in Terms of BOD Loading	138
Figure 4.9:	Capital Costs Associated With Various Treatment Processes	141

LIST OF TABLES

Table 1.1:	Summary of Treatment Efficiency and Chemical Addition of Various Advance Primary Treatment Plants	15
Table 1.2:	Summary of Treatment Efficiency and Chemical Addition for Chemical Secondary Treatment Plants in Norway	16
Table 1.3:	Effectiveness of Different Wastewater Treatment Processes	19
Table 1.4:	Common Chemical Compounds Used in Wastewater Treatment	28
Table 2.1:	1985 Average Treatment Results for 23 Direct Precipitation Plants in Norway (Odegaard, 1989)	58
Table 3.1:	Retention Times Associated With Half of the Total Flow Through SESD's Treatment Plant	71
Table 3.2:	Overflow Rates (gpd/ft ²) Associated With Half of the Total Flow Through SESD's Treatment Plant	72
Table 3.3:	Results of Jar Testing by Delta at SESD on October 10, 1989	75
Table 3.4:	Results of Jar Testing by Delta at SESD on October 24, 1989	75
Table 3.5:	Results of Jar Testing by Delta at SESD on December 5, 1989	76
Table 3.6:	Jar Test Results at SESD From January 16-23, 1990 (Tighe & Bond, February 1990)	81
Table 3.7:	Jar Test Results at SESD From January 16-23, 1990 for Different Manufacturers (Tighe & Bond, February 1990)	82
Table 3.8:	Analysis of the Beverly, Danvers, and Marblehead Flow at SESD	87
Table 3.9:	Results From Full Scale Test #1 on the Beverly, Danvers, and Marblehead Side	89
Table 3.10:	Results From Full Scale Test #2 on the Beverly, Danvers, and Marblehead Side	91
Table 3.11:	Chemical Concentration (mg/l) for Test #4	96
Table 3.12:	Particle Size Distribution for Influent and Effluent Data at SESD	102
Table 4.1:	Composition of Organic Material in Wastewater	115
Table 4.2:	Volume Requirements for an Activated Sludge Aeration Basin Based on BOD Loading	118
Table 4.3:	Volume Requirements for Tricking Filters Based on BOD Loading	120
Table 4.4:	Comparison of Volume Requirements for Activated Sludge Aeration Basins and Tricking Filters Based on BOD Loading	121
Table 4.5:	Alum Requirement for a Given Phosphorus Removal Rate	124

Table 4.6:	Typical Solids Content of Sludge Resulting From Various Conventional Treatment Processes	128
Table 4.7:	Volume of Sludge Resulting From a Change in the Solids Content	129
Table 4.8:	Solids Content of the Sludge Produced at Various Advanced Primary Treatment Facilities	130
Table 4.9:	Comparison of SESD's Sludge Solids Content During Chemical Testing (March 25 - April 16)	130
Table 4.10:	Sludge Characteristics at Various Treatment Facilities	131
Table 4.11:	Dewatering Characteristics at Various Treatment Facilities	132
Table 4.12:	Dewatering Solid Cake Comparison at SESD	132
Table 4.13:	The Weight and Cost of Various Chemicals	137

Chapter 1

INTRODUCTION TO CHEMICALLY-ENHANCED WASTEWATER TREATMENT

1.1 Introduction

The Clean Water Act of 1972, as administered by EPA, requires secondary treatment for all municipal discharges. Secondary treatment, usually a biological process, is required to remove 85% of total suspended solids (TSS) and biochemical oxygen demand (BOD) and produce a minimum final effluent of 30 mg/l for both of these conventional pollutants.

In freshwater environments, high levels of BOD removals are essential to prevent low dissolved oxygen levels. In coastal waters, high levels of BOD removal are not as critical because of the large surface area available for reaeration. High removal rates for suspended solids are considered beneficial because toxic materials tend to be adsorbed onto particulates.

A disadvantage of the biological oxidation process used in most secondary treatment plants is that it is not effective in removing phosphorus. In addition, this process produces nitrate nitrogen. Both nutrients stimulate algal growth and subsequent algal decomposition provides a new source of BOD that tends to nullify the high BOD removal in the biological secondary treatment process. An optimal waste treatment process for coastal waters would be one that removes relatively high levels of TSS and phosphorus and intermediate-to-high levels of BOD without oxidizing organic nitrogen.

A viable alternative to biological secondary treatment for coastal waters is chemically-enhanced primary treatment. In this process, chemicals and polymers are added to primary sedimentation tanks to enhance solids removal through coagulation and flocculation. Besides enhancing solids removals, the chemical treatment process also removes much of the phosphorus, heavy metals, and BOD associated with small particles. For example, using chemicals to enhance settling has resulted in TSS removal rates ranging from 80% - 95% and BOD removal rates ranging from 50% - 85% compared to 60% TSS removal and 35% BOD removal in conventional primary treatment. Using chemical

treatment, these higher removal rates can be maintained even with a much higher overflow rate.

There are essentially two types of chemically-enhanced treatment (Figure 1.1): advanced primary and chemical secondary. Advanced primary treatment (Figure 1.1a) has been used for over seven years in southern California and Canada (Table 1.1). This type of treatment is usually done with minimal additional construction to conventional primary treatment plants; therefore, little capital cost is required to convert a primary treatment plant to an advanced primary treatment plant. This treatment consists of adding metal salts (such as ferric chloride or alum) and/or cationic polymers and an anionic polymer to the wastestream to enhance settling. The metal salts, which are used as a coagulating agent, need rapid mixing in order to optimize the coagulation process. The metal salt (20-30 mg/l) should be added as far upstream of the sedimentation tanks as possible to allow enough mixing time for the coagulation process to occur. The anionic polymer needs rapid mixing initially to dilute the polymer, then gentle mixing to promote flocculation and the formation of large settleable flocs. The anionic polymer (0.2-0.3 mg/l) should be added ahead of the sedimentation tanks. This type of treatment has consistently achieved 80% TSS, 50-60% BOD, and 85% phosphorus removals.

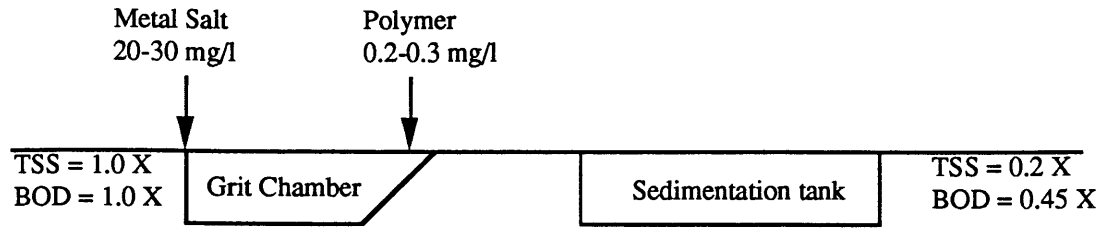

Figure 1a. Advanced Primary Treatment

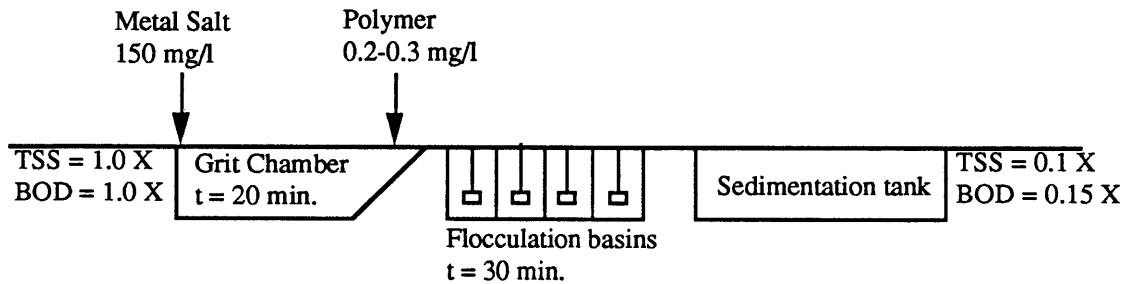

Figure 1b. Chemical Secondary Treatment

Figure 1.1: Various Chemical Treatment Processes (Harleman and Morrissey, 1990)

The second type of chemically-enhanced treatment is chemical secondary (Figure 1.1b). This type of treatment is being used in Norway and Sweden (Table 1.2) in plants designed to optimize the chemical treatment process. The treatment consists of about 150 mg/l of a metal salt and 0.2-0.3 mg/l of an anionic polymer. The difference between this type of treatment and advanced primary is that in the chemical secondary process, flocculation basins are provided before the sedimentation tanks to maximize the flocculation process. These flocculation basins are in series, with the mixing rates becoming progressively slower, as the wastewater approaches the sedimentation tanks. The metal salt is added approximately 20 minutes upstream of the flocculation basins. The anionic polymer is added before the flocculation basins and is mixed with the wastewater and metal salt for approximately 30 minutes before reaching the sedimentation tanks. This type of

treatment has consistently achieved 90% TSS, 85% BOD, and 95% phosphorus removals (Odegaard, 1988).

Table 1.1: Summary of Treatment Efficiency and Chemical Addition for Various Advanced Primary Treatment Plants

Location	Performance					Chemical Addition		
	Flow mgd	BOD (mg/l)		TSS (mg/l)		Type	Conc ppm	Duration
		inf	eff	inf	eff			
Pt. Loma ¹ City of San Diego	191	276	119	305	60	FeCl ₃ Anionic Poly	35 0.26	continuous
Orange County ² Plant #1	60	263	162	229	81	FeCl ₃ Anionic Poly	20 0.25	8 hours peak flow
Orange County ² Plant #2	184	248	134	232	71	FeCl ₃ Anionic Poly	30 0.14	12 hours peak flow
JWPCP ³ Los Angeles County	380	365	210	475	105	Anionic Poly	0.15	continuous
Hyperion ⁴ City of Los Angeles	370	300	145	270	45	FeCl ₃ Anionic Poly	20 0.25	continuous
Sarnia ⁵ Ontario, Canada	10	98	49	124	25	FeCl ₃ Anionic Poly	17 0.3	continuous

Source: 1) Konopka, 1990; 2) Pamson, 1990; 3) Hanson, 1990; 4) Shao, 1990; 5) Burns, 1990

Table 1.2: Summary of Treatment Efficiency and Chemical Addition
for Chemical Secondary Treatment Plants in Norway

Location	Performance						Chemical Addition			
	Flow mgd	P _{tot} (mg/l)		BOD (mg/l)		TSS (mg/l)		Type	Conc ppm	T _{mix} min
		inf	eff	inf	eff	inf	eff			
Average of 23 plants from Norway		5.5	0.5	216	42	172	27	Lime/FeCl ₃	2-200	20
								Anionic Poly	0-0.2	30
Oslo, Norway	62	2.9	0.14	140	30	120	10	FeCl ₃	150	15
								Anionic Poly	0.2	30

Source: Karlsson, 1988

1.2 History

The historical information given below on the use of chemicals to enhance settling in wastewater has been extracted from Culp (1967).

Since recorded history, man has used natural material to clarify turbid water. Materials such as crushed almonds and beans and alum were used. For wastewater, the first attempt at chemical treatment was made in 1740 in Paris. By 1890, over 200 chemical plants were operational in England. These plants used lime and iron salts as coagulants and usually obtained high TSS removal rates. By 1910, all these chemical treatment plants were replaced by conventional primary and biological processes due to lack of stability, expense, and the production of large quantities of sludge.

In the U.S., only a few early plants were built for chemical treatment and they were eventually abandoned for biological treatment. In 1929, an article (Rudolfs, et. al., 1929) appeared describing the benefits of small concentrations (5 - 15 mg/l) of ferric chloride (FeCl₃) in wastewater. It was observed that a small concentration of FeCl₃ could produce a marked increase in the settling velocity of particles. This article brought about a resurgence of chemical treatment.

In the 1930's, a number of treatment plants throughout the U.S. began to use chemicals to improve settling in the primary sedimentation tanks. Chemical concentrations ranged from 70 to 700 mg/l with an average TSS removal of 80 - 90% and BOD removal of 50 - 80%. One particular plant in 1935 was adding 30 mg/l of lime and 38 mg/l of FeCl_3 and obtaining removal rates of 92% TSS and 76% BOD with a sludge volume increase of 1.5 times over conventional primary.

In the 1930's and 40's, a number of attempts were made to eliminate the biological process by using a chemical treatment process while providing the same high quality effluent. Some of these processes include the Laughlin, Guggenheim, Laudreth, Streander and Stevenson process. These processes all included the use of lime with another coagulant or coagulant aid to promote settling. Each process used a single flocculation basin, took up half the space required by the activated sludge process, and produced equivalent or better effluent than the activated sludge process. However, operating costs were much higher. Attempts were made to reduce the costs by reusing the coagulant with little success.

Between 1940 and about 1965, there was little interest in the use of chemicals in wastewater treatment. It was not until it was recognized that phosphorus was important in controlling eutrophication that advanced wastewater treatment (AWT) was introduced into the United States. This process included the use of chemicals after secondary treatment to remove nutrients. It was not until early 1980's that wastewater treatment facilities began to use a combination of metal salts and polymers in the treatment process. In Sarnia, Ontario Canada, ferric chloride and polymers were added to the wastewater before the primary sedimentation tanks. This was primarily done for phosphorus removal; however, high TSS and BOD removal rates resulted. Currently, most of the work in the U.S. and abroad on chemical treatment is geared towards phosphorus removal.

In summary, it is apparent that large concentrations of chemicals and the failure to optimize the coagulation and flocculation process has resulted in a lack of interest in the chemical treatment process. According to many classical textbooks on wastewater treatment (M&E, 1979 and Culp, et al., 1978), the reason chemical treatment has seen limited use in the U.S. is that it produces large volumes of sludge that are difficult to handle and dispose of. As an example of chemical treatment, Metcalf & Eddy (1979) used 400 mg/l of lime to obtain 85% removal of suspended solids. These results indicate a 2.5 times increase in the volume of sludge produced over biological secondary treatment. It is little

wonder that this process has fallen by the wayside. Today, with the use of polymers, increased interest in nutrient removal, and rising construction and energy costs, it is time to revisit chemical treatment as a means of optimizing our removal efficiency in the initial stages of treatment.

1.3 Comparison of Treatment Processes

A comparison of various treatment processes is shown in Table 1.3. Conventional primary, advanced primary (Figure 1.1a), biological secondary, and chemical secondary (Figure 1.1b) treatment processes are compared in terms of TSS removal, BOD removal, total phosphorus removal, and the amount of dry sludge produced. Conventional primary treatment includes pre-treatment, grit removal, and primary sedimentation. Advanced primary treatment is the same as conventional primary treatment with the addition of chemicals before the sedimentation tanks. Biological secondary treatment includes conventional primary treatment followed by a biological process (ie. aeration tanks and secondary settling tanks). Chemical secondary treatment includes pre-treatment, grit removal, flocculation basins, primary sedimentation, and chemical addition. The amount of dry sludge produced is compared to the sludge resulting if the facility only had a conventional primary plant obtaining 60% TSS and 35% BOD removals.

1.4 Coagulation and Flocculation

The chemically-enhanced wastewater treatment process is one in which chemicals are added to the wastestream to enhance settling. This process includes coagulation, flocculation, and sedimentation and can be described as the bringing together of small particles to form larger particles that group together and settle more rapidly than the individual particles. When these groups of particles settle, they carry with them smaller particles that get trapped beneath the larger groups of particles as they fall.

The terms coagulation and flocculation have been used interchangeably (O'Melia, 1970) or lumped into one term, coagulation (AWWA, 1971). In this report, the terms coagulation and flocculation will have separate meanings. Coagulation is defined as the bringing together of small particles to form larger particles. Flocculation, a transport process, is defined as the bringing together of these coagulated particles to form large

Table 1.3: Effectiveness of Different Wastewater Treatment Processes

Treatment Type	TSS Removed	BOD Removed	P Removed	Sludge Produced (Dry wt. / day)
Primary	60%	35%	20%	X
Advanced Primary ¹ (Polymer + FeCl ₃)	80%	57%	85%	1.33 X (TSS) <u>0.12 X (Chemicals)</u> 1.45 X (total)
Biological Secondary ²	85%	85%	30%	1.42 X (TSS) <u>0.48 X (new Biomass)</u> 1.90 X (total)
Chemical Secondary ³ (Polymer + FeCl ₃)	91%	80%	95%	1.53 X (TSS) <u>0.47 X (Chemicals)</u> 2.00 X (total)

1. Advanced Primary (Polymer) Treatment results are from San Diego, CA -- Pt. Loma plant operations data (Langworthy, 1990)

2. Biological Secondary Treatment results are from Black & Veatch Inc., Boston, MA. January 1988. Residual Management Facilities Plan: Draft Characterization of Residuals, Suppl. Rep. No. 1. Prepared for MWRA.

3. Chemical Secondary Treatment results are from Oslo, Norway (Paul Sagberg, 1990)

TSS = total suspended solids

BOD = biochemical oxygen demand

P = total phosphorus

FeCl₃ = ferric chloride

groups of particles called flocs. Coagulation and flocculation can be more fully described by particle destabilization and particle transport respectively. There has been confusion in the use of these terms because transport is needed for particles to come in contact before destabilization can take place. Then, the destabilized particles must be transported so that they can come in contact and form larger particles.

The term precipitation, which is a part of coagulation, refers to the chemical reaction that converts a truly soluble substance into a solid. For example, the following reaction results in the precipitation of phosphorus.



A coagulant such as FeCl_3 , also forms precipitants such as $\text{Fe}(\text{OH})_3$ when it reacts with the wastewater. Hence, precipitation is a big part of the coagulation process and is of primary importance in the process of sweep coagulation and phosphorus removal.

Conventional primary sedimentation results from discrete particle settling where gravitational forces are dominant. This process usually removes particles larger than $40 \mu\text{m}$ (Figure 1.2). A large percentage of the total solids that are not removed by conventional primary treatment are smaller than $1 \mu\text{m}$ and are classified as colloids. For colloids, the surface area is very large with respect to the volume; therefore, surface phenomena such as electrostatic repulsion and hydration are important. To illustrate the effect size can have on surface area, if a $10 \mu\text{m}$ cube with the surface area of $60 \mu\text{m}^2$ is cut into $0.1 \mu\text{m}$ cubes, then the total surface area for this amount of mass would be $60,000 \mu\text{m}^2$. Hence, smaller particles have larger surface areas in which reactions occur.

In wastewater, colloids are stable due to their surface charge and affinity to water and do not aggregate. In order to coagulate these colloids, a destabilization process must occur.

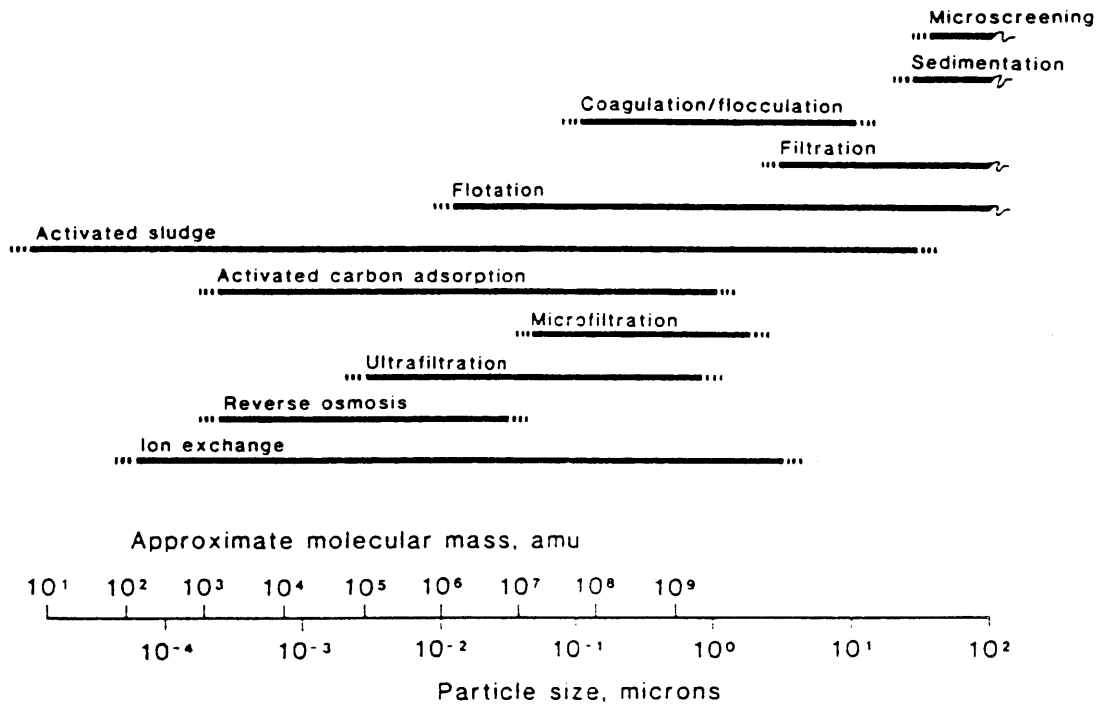

Figure 1.2: Distribution of Particle Sizes Removed by Different Treatment Processes (Levine, et al., 1987)

1.4.1 Coagulation (Particle Destabilization)

Particle destabilization is based on colloid and surface chemistry in which particles must be able to adhere to each other when brought into contact. Destabilization is very rapid once the particles are brought into contact with one another. There are three particle destabilization processes. These processes include sweep coagulation, charge neutralization, and interparticle bridging (sometimes associated with flocculation). In sweep coagulation, a large amount of metal salt (such as alum or ferric chloride) is added to the wastewater so that the metal hydroxide formed by precipitation ($\text{Al}(\text{OH})_3$ and $\text{Fe}(\text{OH})_3$) settle very rapidly. When these metals precipitate, they carry with them smaller colloidal size particles.

Wastewater generally has a net negative charge due to the preferential adsorption of anions onto surfaces of organic matter. Therefore, in charge neutralization, positively charged coagulants (metal salts and/or small molecular weight polymers) are introduced into the wastewater. The cationic coagulants compress the diffusive layer around the particles (see article on double layer theory by Black, 1960) causing the Van der Waals' (cohesive) forces of attraction to increase and resulting in a sticking of the particles. The cationic coagulants also adsorb onto the particles causing an increase in particle size and settling velocity. In order for charge neutralization to occur, monomeric metal hydrolysis products ($\text{Al}(\text{OH})^+$ and $\text{Fe}(\text{OH})^+$) which are formed within microseconds, and small polymeric products ($\text{Al}(\text{OH})_3$ and $\text{Fe}(\text{OH})_3$) which are formed within a second (AWWA, 1989) must be brought in contact with particles in the wastewater. There must be rapid mixing for charge neutralization to occur. Fettig, Ratnaweera, and Odegaard (1990) has shown that metal salts (alum) can be replaced by a cationic polymer at a ratio of 7.5:1 without affecting the removal rates of TSS and BOD and while dramatically reducing the amount of sludge produced. However, the cationic polymer does not precipitate phosphorus.

During interparticle bridging, a bridge is formed by a large polymer in the small region between two particles that repel each other. Once this begins to happen, a network or group of coagulated particles results. This network or group of particles is often referred to as a floc. Figure 1.3 shows a schematic representation of interparticle bridging as can occur in the coagulation of colloids using polymers. Reactions 1-6 show the initial adsorption onto a colloid with an optimum polymer dosage, floc formation after

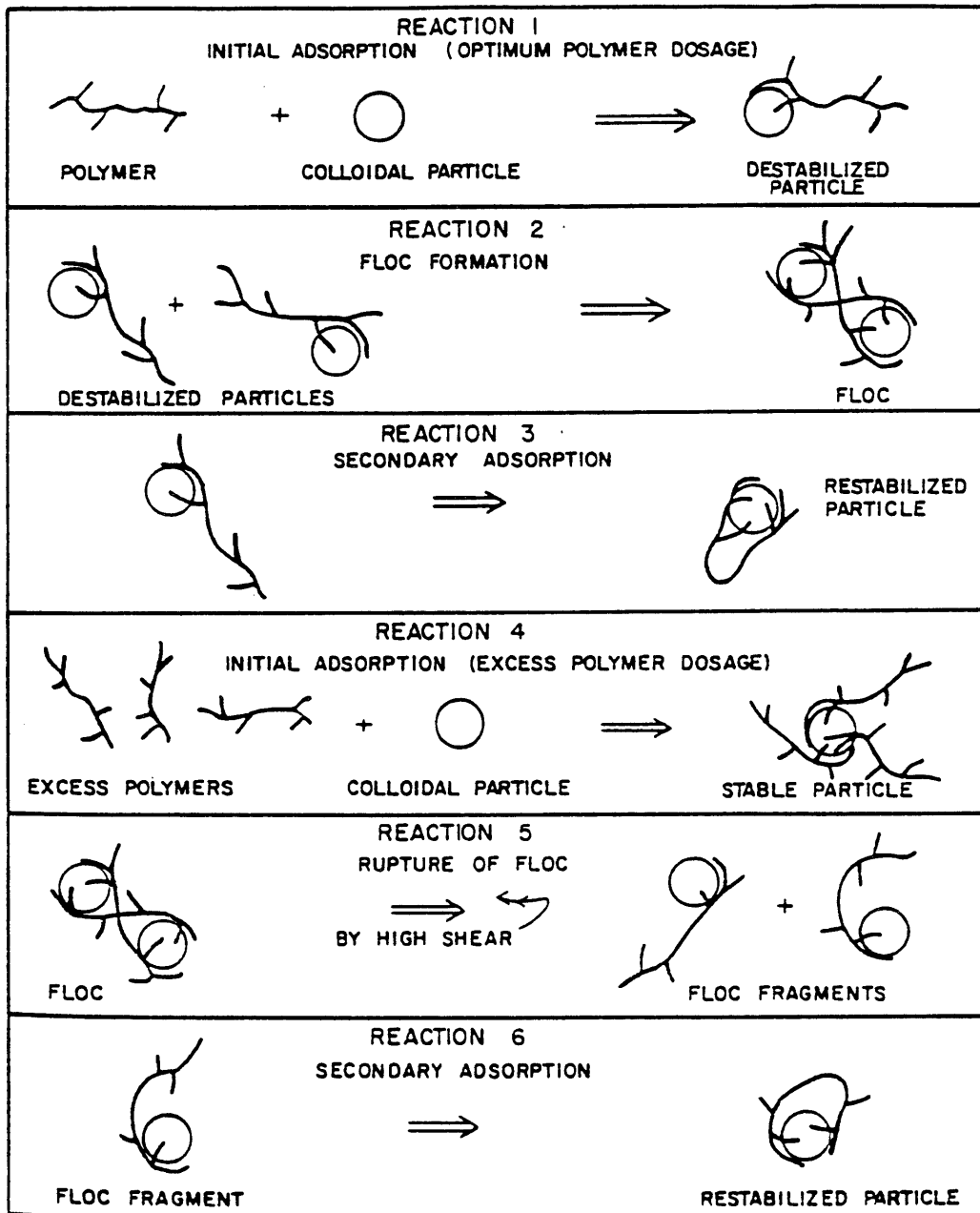

Figure 1.3: Schematic Representation of Intreparticle Bridging as Can Occur in the Coagulation of Colloids With Polymers (O'Melia, 1970)

destabilization, a restabilization of particles bringing a halt to all further floc formation, an overdosing of polymers causing stabilization of the colloids, break-up of an already-formed floc by shear forces, and restabilization caused by excess agitation and mixing.

The basic mechanism for particle destabilization (coagulation) has historically been explained through two opposing theories: chemical theory and physical theory. It is recognized today that these theories are not opposing but are both important in explaining coagulation. A brief explanation of each theory is given below. For a more detailed explanation see reference by Stumm and Morgan (1962), and Black (1960).

The chemical theory emphasizes the chemical interactions between coagulation and colloids. The colloids are assumed to be aggregates of definite chemical structural units where coagulation results from precipitation of insoluble complexes, which are formed by specific chemical reactions (AWWA, 1971).

The physical theory, often referred to as the double-layer theory, emphasizes the importance of the electrical double layer surrounding the colloidal particles in solution. In particular, the effects this layer has on the oppositely charged ion adsorbed and zeta potential reduction in the destabilization of colloidal systems (AWWA, 1971). As mentioned before, both theories are needed to explain particle destabilization.

1.4.2 Flocculation (Particle Transport)

Particle transport is necessary to bring destabilized particles together and promote collisions between particles. Once these particles are in contact, the effectiveness of the particle-particle adhesion (α) will determine whether the particle will aggregate. When these particles aggregate, large particles are formed resulting in an increase in the size and density of the individual particles and a reduction in the overall number of particles present. This transport process is usually accomplished by slow mixing in order to keep particles in suspension long enough to allow collisions to occur. Collisions occur because of three mechanisms: Brownian motion (perikinetic flocculation), shear force (orthokinetic flocculation), and differential sedimentation (a special case of orthokinetic flocculation).

Brownian motion is due to the thermal energy of the fluid. If uniform particles are assumed, Brownian motion is important for collisions between particles $<1.0 \mu\text{m}$

(AWWA, 1989). The rate of change of the total concentration of particles, for a uniform size particle, occurring due to brownian motion is as follows:

$$\partial N/\partial t = -(4/3) \cdot \alpha \cdot (k \cdot T \cdot N^2) / \mu$$

where: N = total number concentration of particles
 t = time
 α = collision efficiency factor ($1 > \alpha > 0$)
 k = Boltzmann's constant
 T = absolute temperature
 μ = fluid viscosity

Shear forces (orthokinetic flocculation) are caused by fluid motion induced by mixing. If uniform particles are assumed, shear force is important for collisions between particles $> 1.0 \mu\text{m}$ (AWWA, 1989). Rapid mixing can have a negative effect on flocculation (Amirtharajah and Trusler, 1986) causing a break-up of the already formed flocs. The rate of change of the total concentration of particles, for a uniform size particle, occurring due to shear forces is as follows:

$$\partial N/\partial t = -(2/3) \cdot \alpha \cdot (G \cdot d^3 \cdot N^2)$$

where: G = mean velocity gradient (time^{-1})
 d = diameter of a particle

Differential settling is a result of external forces acting on the particles (usually gravity). With differential settling, particles settle rapidly overtaking and colliding with particles of slower velocity.

A measure of flocculation performance is the number concentration ratio (N_0/N), which is the ratio of the initial number of particles (N_0) to the number of particles present at time T. As shown in Figure 1.4, the important parameters related to flocculation are the turbulent velocity gradient (G), number of completely mixed reactors in series (m), residence time (T), and floc volume fraction (ϕ). The following conclusions were drawn by Odegaard (1989) from Figure 1.4:

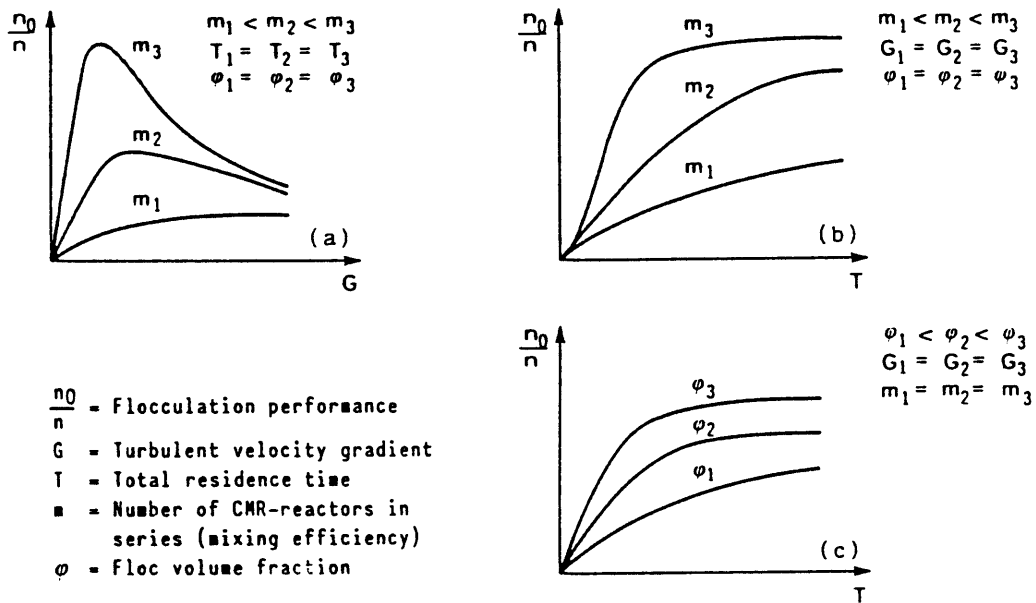

Figure 1.4: Schematic Relationship Between Flocculation Performance and Flocculation Variables (Odegaard, 1989)

- At constant T and ϕ , flocculation performance increases with the intensity of mixing reaching a maximum, after which, performance decreases with an increase in G .
- Performance increases as the number of completely mixed reactors (CMR) in series increases, (ie. approaching plug flow).
- G decreases with an increase in the number of CMR.
- At constant G and ϕ , performance increases with an increase in residence time reaching a maximum, after which, performance does not improve with an increase in residence time.
- The residence time for optimum performance decreases with the number of CMR in series.
- At constant G, M , and T , the higher the floc volume, the higher the performance.
- At higher floc volumes, shorter retention times are needed to obtain similar performance.

Therefore, a series of mixing tanks at progressively slower mixing rates will produce the most floc and have the highest removal efficiency. Flocculation is often accomplished by the use of a flocculant aid such as a high molecular weight anionic polymer.

1.5 Chemicals

There are many combinations of chemicals and polyelectrolytes (polymers) that have been used in treating wastewater. Some of these chemicals have been used in combination with seawater, fly ash, clay, and various other coagulant aids to promote settling. In this section, only alum, lime, ferric chloride, seawater, and polymers will be discussed.

1.5.1 Natural Organic Compounds

Below in Table 1.4 is a list of natural organic chemicals used as coagulants in wastewater along with their chemical formula, molecular weight and valence.

Table 1.4: Common Chemical Compounds Used in Wastewater Treatment

Chemical Name	Chemical Formula	Molecular Weight	Valence
Alum	$\text{Al}_2(\text{SO}_4)_3 \cdot 18 \text{H}_2\text{O}$	666.7	3+
Lime	$\text{Ca}(\text{OH})_2$	56	2+
Ferric Chloride	FeCl_3	162.1	3+

1.5.1.1 Alum

Aluminum sulfate (alum) is a metal salt ($\text{Al}_2(\text{SO}_4)_3 \cdot 18 \text{H}_2\text{O}$) that dissolves readily in water. When alum is added to water with a sufficient amount of bicarbonate alkalinity (approximately half the concentration of the alum), the following reaction occurs and aluminum hydroxide is formed.

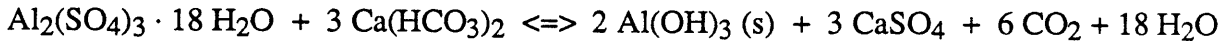

Along with forming aluminum hydroxide ($\text{Al}(\text{OH})_3$), many different ions of aluminum are formed when alum comes in contact with the wastewater. These ions and polymers are effective coagulants because they readily adsorb onto the surface of negatively charged colloids. Large amounts of $\text{Al}(\text{OH})_3$ are effective in terms of sweep coagulation; however, more sludge is produced which is harder to dewater than sludge generated by destabilization (O'Melia, 1978).

1.5.1.2 Lime

Lime ($\text{Ca}(\text{OH})_2$) dissolves readily in water. When lime is added to water with a sufficient amount of bicarbonate alkalinity (approximately two times the concentration of lime), the following reaction occurs and calcium carbonate is formed.

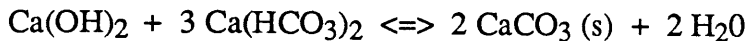

Calcium carbonate is the coagulant formed when lime is in contact with wastewater. A large quantity of lime is needed before lime works as a sweep coagulant because it reacts

readily with carbonic acid. The advantage of lime is that it results in high levels of pH and works as a disinfectant. One way to reduce the amount of lime used is to recycle the sludge water since it is high in pH and can also be used as a coagulant. The addition of lime has been historically used in treating wastewater and is strongly dependent on the pH and alkalinity of the wastewater (Figure 1.5). Lime sludge is voluminous but is easy to dewater.

1.5.1.3 Ferric Chloride

Ferric chloride (FeCl_3) is a metal salt that dissolves readily in water. When ferric chloride is added to water the following reaction occurs and ferric hydroxide is formed.

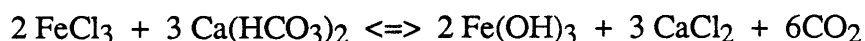

Along with forming ferric hydroxide ($\text{Fe}(\text{OH})_3$), many different ions of iron are formed when ferric chloride comes in contact with the wastewater. These ions and polymers are effective coagulants because they readily adsorb onto the surface of negatively charged colloids. Large amounts of $\text{Fe}(\text{OH})_3$ are effective in terms of sweep coagulation; however, more sludge is produced which is harder to dewater than sludge generated by destabilization (O'Melia, 1978). In wastewater with low bicarbonate alkalinity, alum is better to use assuming that alum performs the same as ferric chloride and lime at the same concentrations.

1.5.1.4 Seawater

Seawater contains many metal salts of Ca, Mg, and Na with NaCl being of primary concern. For coastal cities, this is an inexpensive means of adding coagulant to the wastewater to enhance settling. The following reaction would result if only NaCl is considered.

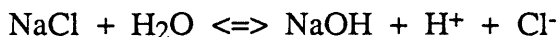

Seawater is currently being used in Scandinavia and could prove beneficial for many coastal municipalities. Further investigation is warranted in this area.

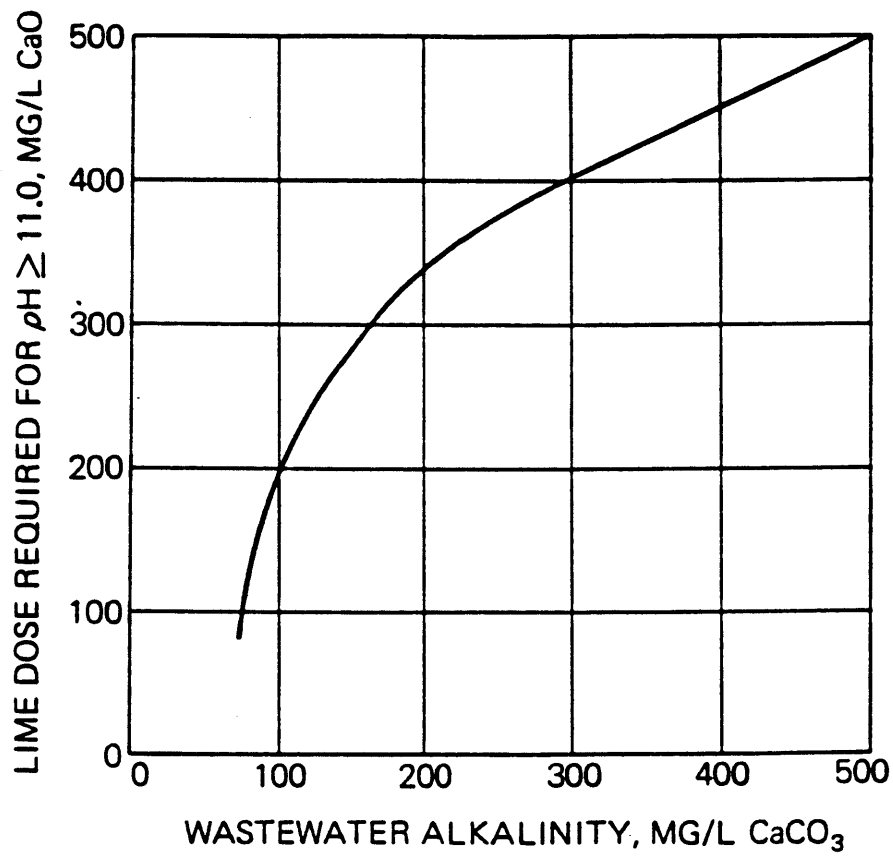

Figure 1.5: Relationship Between Lime Concentration and Alkalinity (Culp, et al., 1978)

1.5.2 Synthetic Organic Polyelectrolytes (Polymers)

A polyelectrolyte (polymer) is a long chain of small subunits or monomers. They have a high molecular weight, usually greater than 100,000. The types of polymers used in wastewater treatment are water soluble and have also been approved for use in clarifying potable water. Polymers can be positively charged (cationic), negatively charged (anionic), or uncharged (nonionic). Figure 1.6 is a schematic of a cationic polymer. Each location where a "+" appears is called a site. Each site can attach an oppositely charged ion onto it. Therefore, polymers are usually highly charged (except for nonionic polymers) with many sites open for possible reaction.

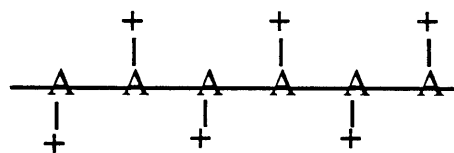

Figure 1.6: Schematic of a Cationic Polymer

There are two ways that polymers destabilize colloidal particles. First, oppositely charged particles can be adsorbed onto the polymers. Second, polymers can bridge the small region between two particles that repel each other. In the first case, a small polymer (short chained polymer of relatively low molecular weight) is used to accomplish destabilization. In the second case, a large polymer (long chained polymer of high molecular weight) is needed.

Acrylamide is probably the most important building block of synthetic polyelectrolytes (Klass, et al., 1975 and Jorgensen, 1979). An acrylamide monomer and polymer is shown in Figure 1.7.

Functional groups such as caustics, formaldehyde, and dimethylamine react with the polyacrylamide to form both anionic and cationic polymers. Figure 1.8 shows an example of similar polymers used during the chemical testing studies at SESD (see Chapter 3).

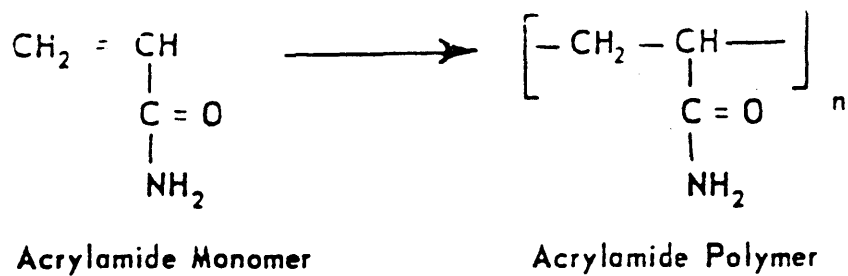

Figure 1.7: Acrylamide Monomer and Polymer (Klass, et al., 1975)

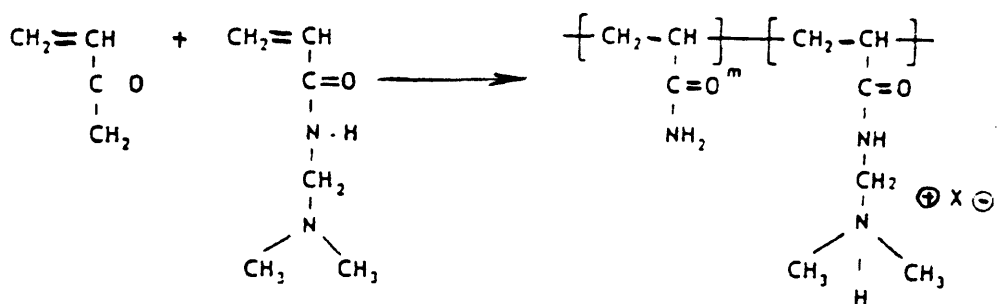
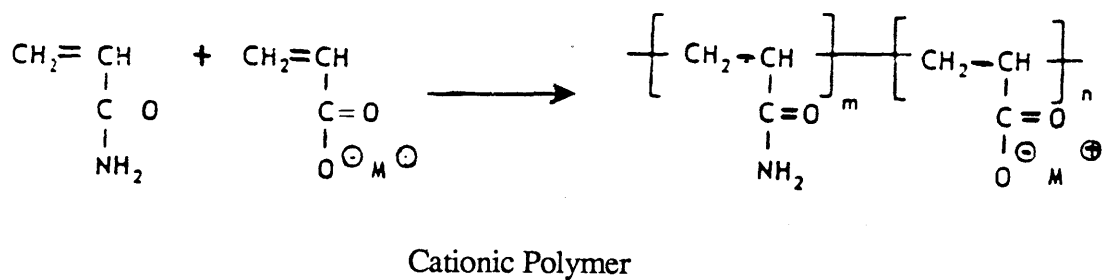

Figure 1.8: Anionic and Cationic Polyacrylamides (Klass, et al., 1975)

The major advantage of using polymers in wastewater treatment is that they are highly charged and can readily destabilize particles, which reduces the amount of metal salts required. This ultimately reduces the amount of sludge produced.

Chapter 2

REVIEW OF EXISTING CHEMICALLY-ENHANCED TREATMENT PLANTS

2.1 Introduction

Many treatment plants use chemicals to aid in disinfection, odor control, digestion, and to improve sludge characteristics. However, only a few plants in the United States are using chemicals to dramatically improve effluent quality and none are designed to optimize the chemical enhancement process. Other countries such as Sweden and Norway use chemical addition to enhance settling in nearly 90% of all treatment plants. This section is intended to review the information available on several of treatment plants that are using chemically-enhanced settling.

2.2 United States and Canadian Plants

There are essentially seven major treatment facilities in the U.S. and Canada that are currently adding chemicals to the primary clarifier in order to improve effluent TSS and BOD quality by promoting coagulation and flocculation. These major treatment plants are as follows:

- Point Loma - The City of San Diego, California
- County Sanitation District - Orange County, California
- JWPCP - Los Angeles County, California
- Hyperion - The City of Los Angeles, California
- North End Plant - Tacoma, Washington
- Sarnia Treatment Plant - Sarnia, Ontario Canada
- Montreal Urban Community Wastewater Treatment Plant - Montreal, Quebec Canada

2.2.1 Point Loma - The City of San Diego, California

The City of San Diego, servicing 1.7 million, currently treats an average of 191 mgd of wastewater at the Point Loma treatment plant. All of the flow entering the plant receives chemical treatment. The plant consists of bar screens, aerated grit chambers, primary sedimentation tanks, sludge digesters, and an ocean outfall (Figure 2.1). The average TSS and BOD₅ influent concentration is 305 mg/l and 276 mg/l respectively (Figure 2.2). The average TSS and BOD₅ effluent concentration is 60 mg/l and 119 mg/l respectively. Effluent is discharged from Point Loma into the ocean through an outfall (equipped with 1,350 ft diffusers) approximately 11,500 ft long at a depth of 200 ft.

To enhance settling, Point Loma adds approximately 35 mg/l of FeCl₃ and 0.26 mg/l of an anionic polymer to the raw wastewater entering the plant. The addition of chemicals to enhance settling has resulted in the following:

- Removal rates of 80%, 57%, and 42% for TSS, BOD₅, oils and grease respectively, and about 80% for total phosphorus.
- Average overflow rates of greater than 1700 gpd/ft² as compared to 800 gpd/ft² for a conventional primary treatment plant.

The City of San Diego is currently under contract with a consulting firm to provide them with a facility plan (Clean Water Program for Greater San Diego, 1990) to meet the needs of the city and to comply with EPA's secondary treatment requirements. The plan consists of two secondary biological facilities and a number of water reclamation facilities. This project is being designed for a flow of 270 mgd at a cost of approximately \$2 billion in 1990 dollars. Between now and when construction begins on the new facility, the city plans to expand their current advanced primary plant to handle a flow of 240 mgd. About the time when this is completed, it is proposed that the advanced primary plant be converted to a 150 mgd high purity oxygen biological secondary facility and the land adjacent to this site be used to construct a 150 mgd advanced primary plant.

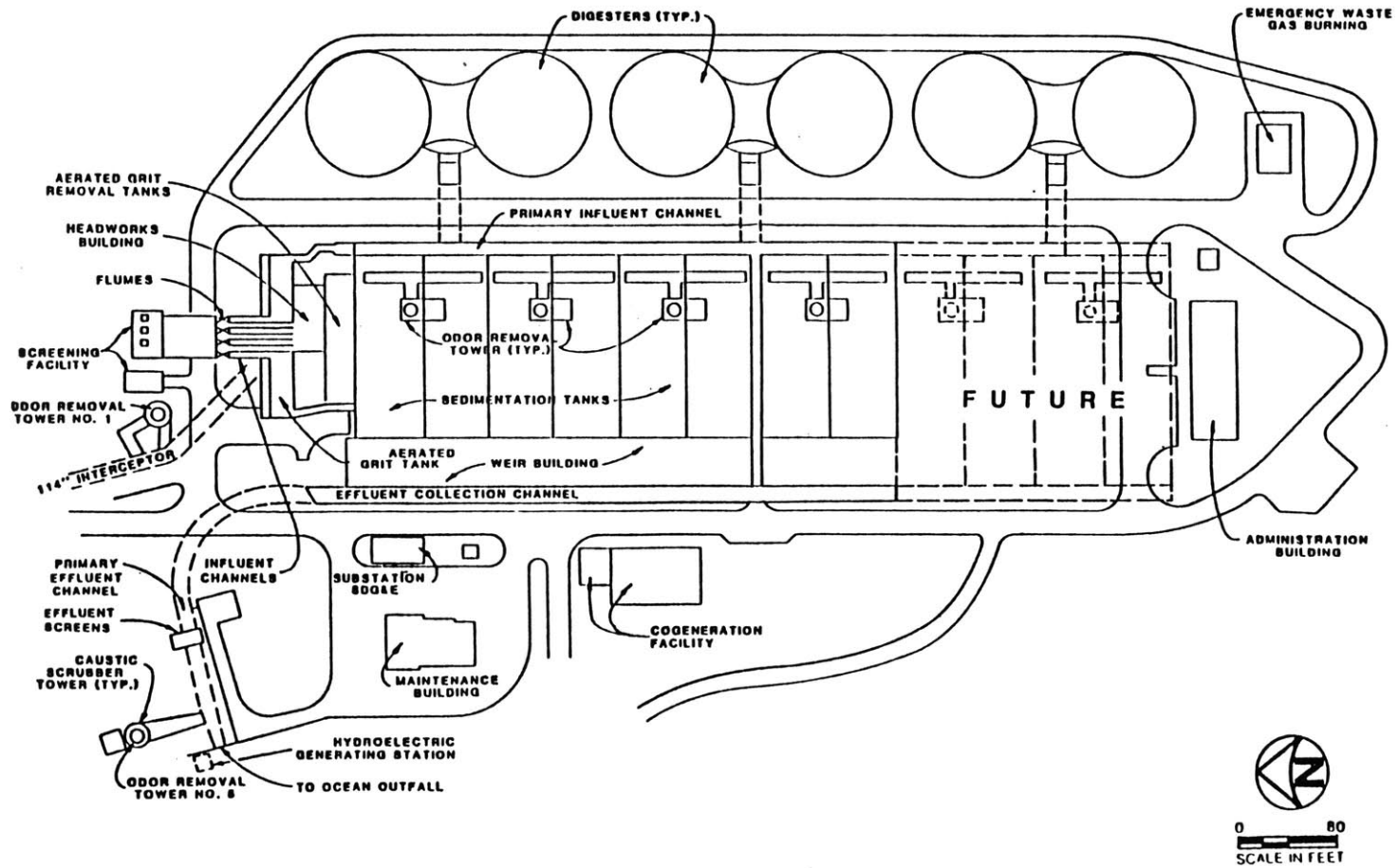

**SITE PLAN OF POINT LOMA
WASTEWATER TREATMENT PLANT**

Figure 2.1: Site Plan of the Point Loma Primary Wastewater Treatment Plant
(Konopka, 1989)

Pt. Loma, San Diego Treatment Facility

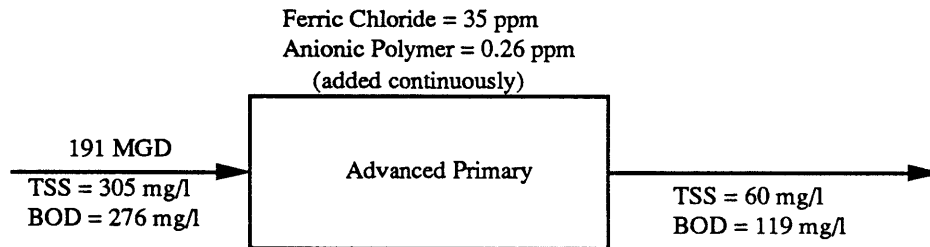

Advanced Primary only:
Removal rate of TSS = 80%
Removal rate of BOD = 57%

Note: 1989 data

Figure 2.2: Flow Diagram of the Point Loma Primary Wastewater Treatment Plant

The effluent from the advanced primary plant will feed the biological secondary plant. It is assumed that the advanced primary plant can only remove 75% of the TSS and 45% of the BOD₅ with an average overflow rate of 1400 gpd/ft². To the south, another facility is being built to handle a flow of 55 mgd. This plant will consist of a conventional primary plant (no chemicals added to enhance settling) and a high purity oxygen biological plant. Upstream reclamation facilities will be built to handle 70 mgd of flow and the effluent will be available for reuse. It is estimated that the reclaimed water will be used only 6 months of the year. The rest of the year, the reclaimed water will be disposed of through a 7000 ft outfall into the ocean.

The city of San Diego should consider using chemicals in their design of the conventional primary facilities for the southern plant. This would allow a sizing down of the primary sedimentation tanks and a reduction in the size of the secondary treatment facility. This reduction in the size is possible because the amount and size of the organic matter that the bacteria has to break-down is reduced, which results in an increase in the biochemical oxidation rate (see Chapter 4). The Point Loma plant is being designed as an advanced primary treatment followed by a high purity oxygen plant; however, the ability to accommodate high overflow rates and the higher biochemical oxidation rates are not being considered.

The most logical step that the city can take is to develop a facilities plan around a chemical secondary plant for 270 mgd on the site that they currently occupy and the adjacent land that would have been needed for the conventional primary facility. This design would include the addition of flocculation basins (see Chapter 4). If it is in the city's best interest to provide reclaimed water upstream of Point Loma, then these reclamation facilities should be considered with chemical secondary treatment followed possibly by filtration to obtain the required water quality.

2.2.2 County Sanitation District - Orange County, California

The Orange County Sanitation District, servicing 1.8 million, currently treats an average of 244 mgd of wastewater at two treatment plants: Plant #1 and Plant #2. All of the flow entering the plants receives chemical treatment. The plants consists of bar screens, grit chambers, primary sedimentation tanks, aeration basins, dissolved air flotation thickeners, secondary sedimentation tanks, trickling filters, belt filter presses, sludge digesters, and an ocean outfall (Figure 2.3). The average TSS and BOD₅ influent concentration for Plant #1 is 229 mg/l and 263 mg/l and Plant #2 is 232 mg/l and 248 mg/l respectively (Figure 2.4 and 2.5). The average TSS and BOD₅ effluent concentration from the advanced primary treatment is 81 mg/l and 162 mg/l for Plant #1 and 72 mg/l and 131 mg/l for Plant #2 respectively. Approximately 60% of the advanced primary effluent undergoes additional treatment by a biological process. The average overall TSS and BOD₅ effluent concentration that is discharged into the ocean is 38 mg/l and 68 mg/l respectively. Effluent from both plants is combined and discharged into the ocean through an outfall (equipped with 5,200 ft diffusers) approximately 26,400 ft long at a depth of 200 ft.

To enhance settling, Orange County adds between 20-30 mg/l of FeCl₃ and 0.15 - 0.25 mg/l of an anionic polymer to the raw wastewater entering the plants. These chemicals are added only during peak flows (8-12 hours). They are currently improving the effect of chemical addition by increasing the time in which the chemicals are added and making adjustments to the hydraulics of the plants. The addition of chemicals to enhance settling at Plant #1 has resulted in Orange County's ability to treat an average of 60 mgd at a plant designed to treat 48 mgd. The overflow rate of the primary clarifiers is 1300 gpd/ft².

The Orange County Sanitation District has applied for a 301 (h) waiver from full secondary treatment. Their application is still being evaluated by EPA. Also of concern for Orange County and all other California municipalities is a referendum that would require all facilities to provide secondary levels of treatment regardless of the waiver status. If their waiver is denied or the states referendum for uniform secondary treatment is passed, Orange County Sanitation District would be required to provide full secondary treatment to all flow entering the plant.

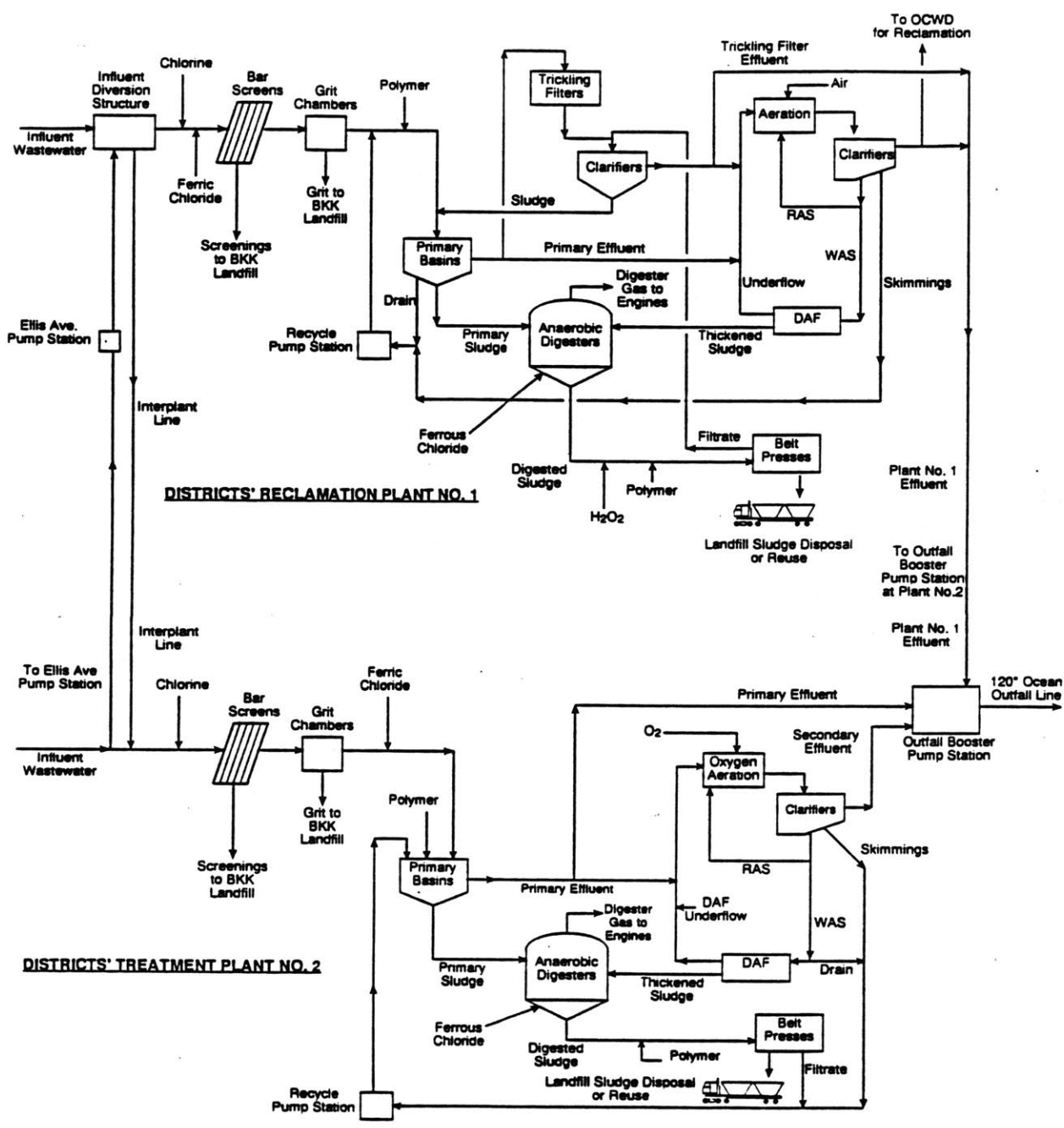
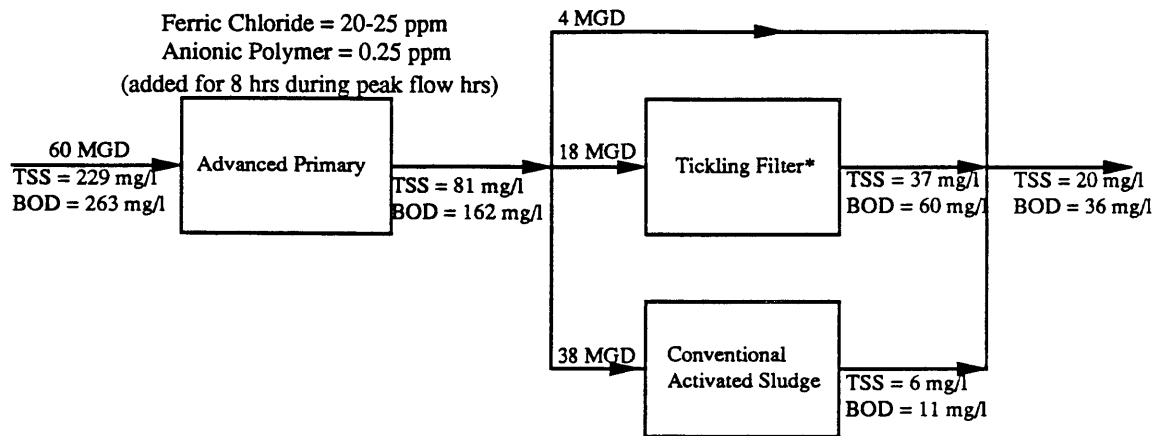

Figure 2.3: Process Diagram of Orange County Sanitation District's Treatment Plants Number 1 and 2 (Pamson, 1989)

Orange County Treatment Facility

Plant #1



Advanced Primary only:

Removal rate of TSS = 65%
Removal rate of BOD = 38%

Tickling Filter only:

Removal rate of TSS = 54%
Removal rate of BOD = 63%

Activated Sludge only:

Removal rate of TSS = 93%
Removal rate of BOD = 93%

Overall Removals:

Removal rate of TSS = 91%
Removal rate of BOD = 86%

Advanced Primary plus Trickling Filter:

Removal rate of TSS = 84%
Removal rate of BOD = 77%

Advanced Primary plus Activated Sludge:

Removal rate of TSS = 97%
Removal rate of BOD = 96%

* Belt press filtrate and wash water is treated directly in the clarifiers serving the trickling filters.

Data for fiscal year 1988-89

Figure 2.4: Flow Diagram of the Orange County Sanitation District's Treatment Plant Number 1

Orange County Treatment Facility

Plant #2

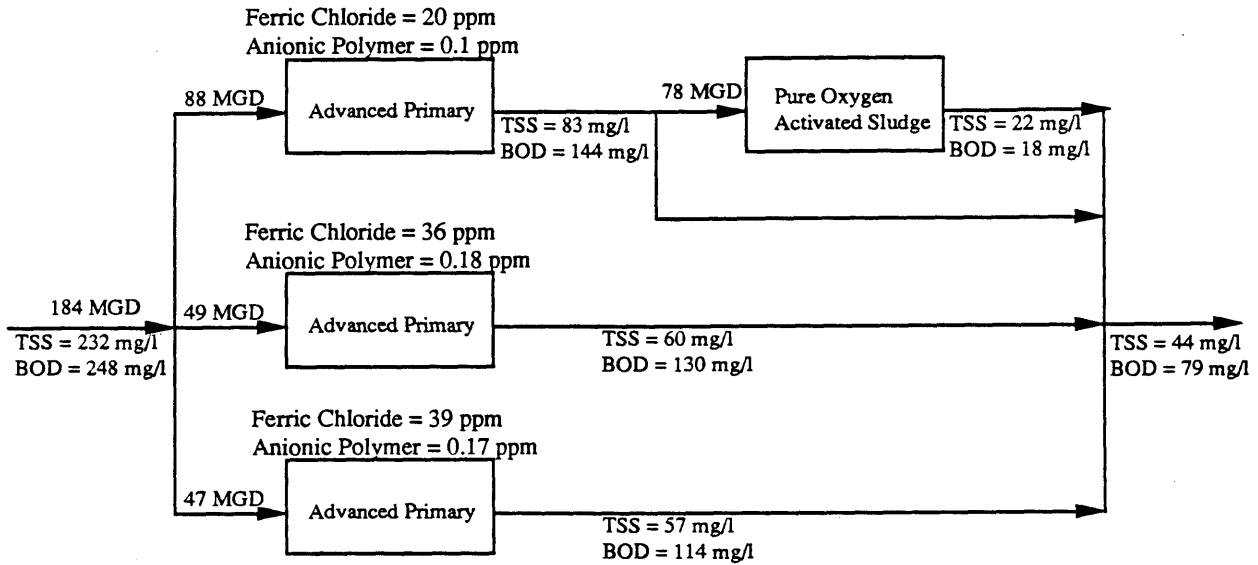

Advanced Primary only:
Removal rate of TSS = 69%
Removal rate of BOD = 47%

Overall Removals:
Removal rate of TSS = 81%
Removal rate of BOD = 68%

Activated Sludge only:
Removal rate of TSS = 73%
Removal rate of BOD = 88%

Advanced Primary plus Activated Sludge:
Removal rate of TSS = 94%
Removal rate of BOD = 95%

Note: Chemicals added for 12 hrs during peak flow hrs
Data for fiscal year 1988-89

Combined Flow from Orange County Plants #1 and #2:

Effluent only:
TSS concentration = 38 mg/l
BOD concentration = 68 mg/l
Removal rate of TSS = 84%
Removal rate of BOD = 73%

Figure 2.5: Flow Diagram of the Orange County Sanitation District's Treatment Plant Number 2

The district has recently completed a study that evaluated three scenarios for wastewater treatment. These scenarios are: (1) to meet only the California Ocean Plan (COP) requirements, (2) to maintain existing concentration limits which are greater than the COP, or (3) to provide full secondary treatment to all the wastewater (OCSD, 1989). The COP states that effluent quality standards for TSS are, for a 30 day average, 75% removal or 60 mg/l, whichever is larger, and no BOD requirement. Currently, the district is discharging effluent that is of higher quality than that required by the COP. No decisions have been made as of this report on which scenario the district will pursue over the long run. However, it is assumed that chemical addition will be a part of their long-term plans.

2.2.3 JWPCP - Los Angeles County, California

The County of Los Angeles, servicing 4 million, currently treats an average of 380 mgd of wastewater at the Joint Water Pollution Control Plant (JWPCP) treatment plant. All of the flow entering the plant receives chemical treatment. The plant consists of bar screens, aerated grit chambers, primary sedimentation tanks, traveling screens, aeration basins, biological secondary tanks, sludge digesters, centrifuges, chlorination tanks, and an ocean outfall (Figure 2.6). The county sanitation district also operates a number of reclamation facilities upstream of JWPCP. Once the solids have been removed from these reclamation plants, the solids (as sludge) are discharged into the collection system and are processed at the JWPCP plant. The average TSS and BOD₅ influent concentration is 475 mg/l and 365 mg/l respectively (Figure 2.7). The average TSS and BOD₅ effluent concentration from the advanced primary treatment is 105 mg/l and 210 mg/l respectively. Approximately 60% of the advanced primary effluent undergoes additional treatment by the biological process. The average overall TSS and BOD₅ effluent concentration is 65 mg/l and 115 mg/l respectively. Effluent is discharged from JWPCP into the ocean through two outfalls. One outfall (equipped with a 4,400 ft diffuser) is approximately 7,400 ft long and the other outfall (equipped with a Y shaped diffuser with each arm extending 2,200 ft) is approximately 8,000 ft long. Both outfalls discharge effluent at a depth of approximately 190 ft.

JOINT WATER POLLUTION CONTROL PLANT PROCESS FLOW DIAGRAM

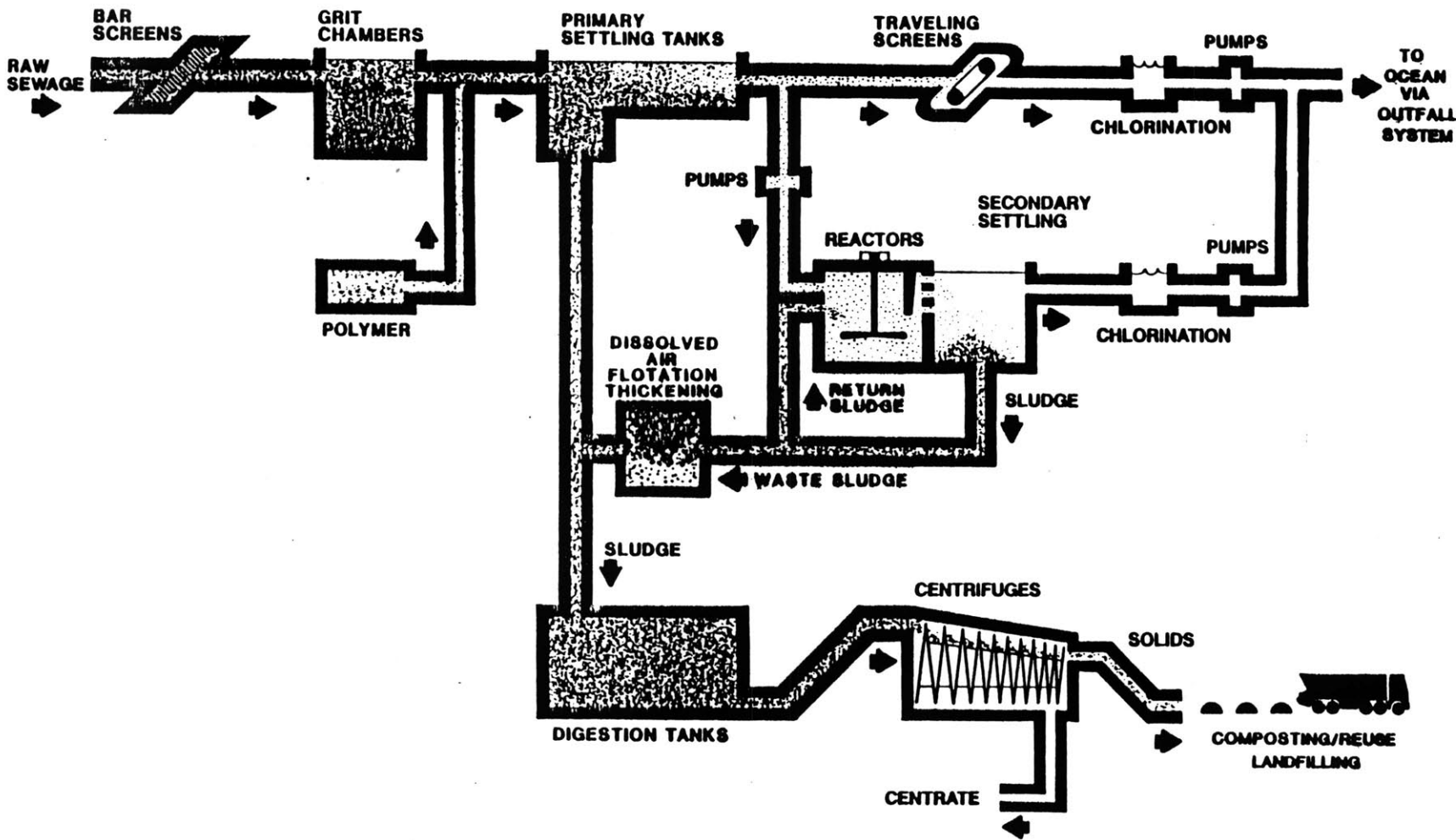
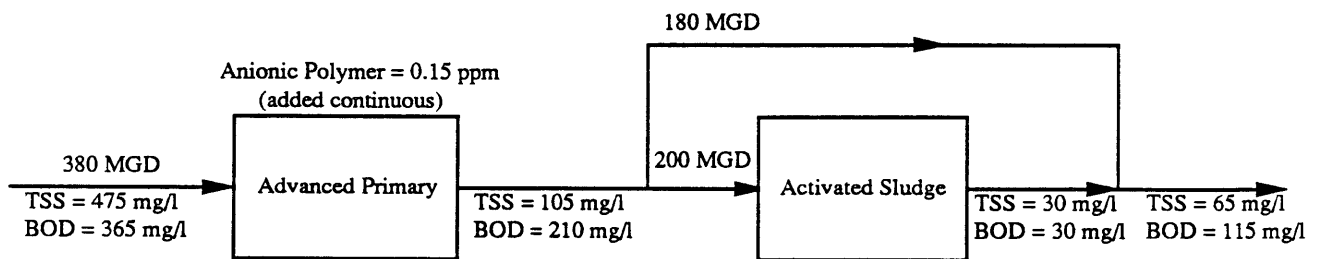

Figure 2.6:

Process Diagram of the Joint Water Pollution Control Plant, Los Angeles

County (Hanson, 1989)

Los Angeles County Treatment Facility JWPCP



Advanced Primary only:
Removal rate of TSS = 78%
Removal rate of BOD = 42%

Overall Removal:
Removal rate of TSS = 86%
Removal rate of BOD = 68%

Activated Sludge only:
Removal rate of TSS = 71%
Removal rate of BOD = 86%

Advanced Primary plus Activated Sludge:
Removal rate of TSS = 94%
Removal rate of BOD = 92%

Figure 2.7: Flow Diagram of the Joint Water Pollution Control Plant, Los Angeles County

A portion of the flow entering JWPCP is from the sludge produced at their upstream water reclamation facilities. Some of the facilities use chemicals to enhance removal rates. These chemicals and the natural coagulation process associated with the high solids concentrations have resulted in JWPCP adding only approximately 0.15 mg/l of an anionic polymer to the raw wastewater entering their plant in order to enhance settling. The addition of an anionic polymer to enhance settling has resulted in the following:

- Removal rates of 78% and 42% for TSS and BOD₅ respectively.
- Average overflow rates for their primary clarifiers are greater than 1300 gpd/ft².

The JWPCP has applied for a 301 (h) waiver from full secondary treatment. Their application has been tentatively denied by EPA. If their waiver is denied, JWPCP would be required to provide full secondary treatment to all flow entering the plant.

JWPCP is different from other municipal facilities in that all engineering is done in-house and consultants are used only to manage the construction effort. They feel this is extremely beneficial because they tell the consultants what is needed instead of the other way around. JWPCP is a very efficient plant (Stahl, 1990). Any changes in their current operations would include chemical addition.

2.2.4 Hyperion - The City of Los Angeles, California

The City of Los Angeles, servicing nearly 4 million, currently treats an average of 370 mgd of wastewater at the Hyperion treatment plant. All of the flow entering the plant receives chemical treatment and 50 - 60 % of the flow also receives biological secondary treatment. The plant consists of bar screens, grit chambers, primary sedimentation tanks, aeration basins, secondary sedimentation tanks, sludge digesters, and two ocean outfall (Figure 2.8). The average TSS and BOD₅ influent concentration is 270 mg/l and 300 mg/l respectively (Figure 2.9). The average TSS and BOD₅ effluent concentration from the advanced primary treatment is 45 mg/l and 145 mg/l respectively. Hyperion has to obtain high removal rates because of chemical addition, proper mixing of the chemicals, increased contact time for the chemicals, and hydraulic changes to the weirs and flow distribution system. The average overall TSS and BOD₅ effluent concentration is 29 mg/l

LIQUID PROCESSES FLOW SCHEMATIC

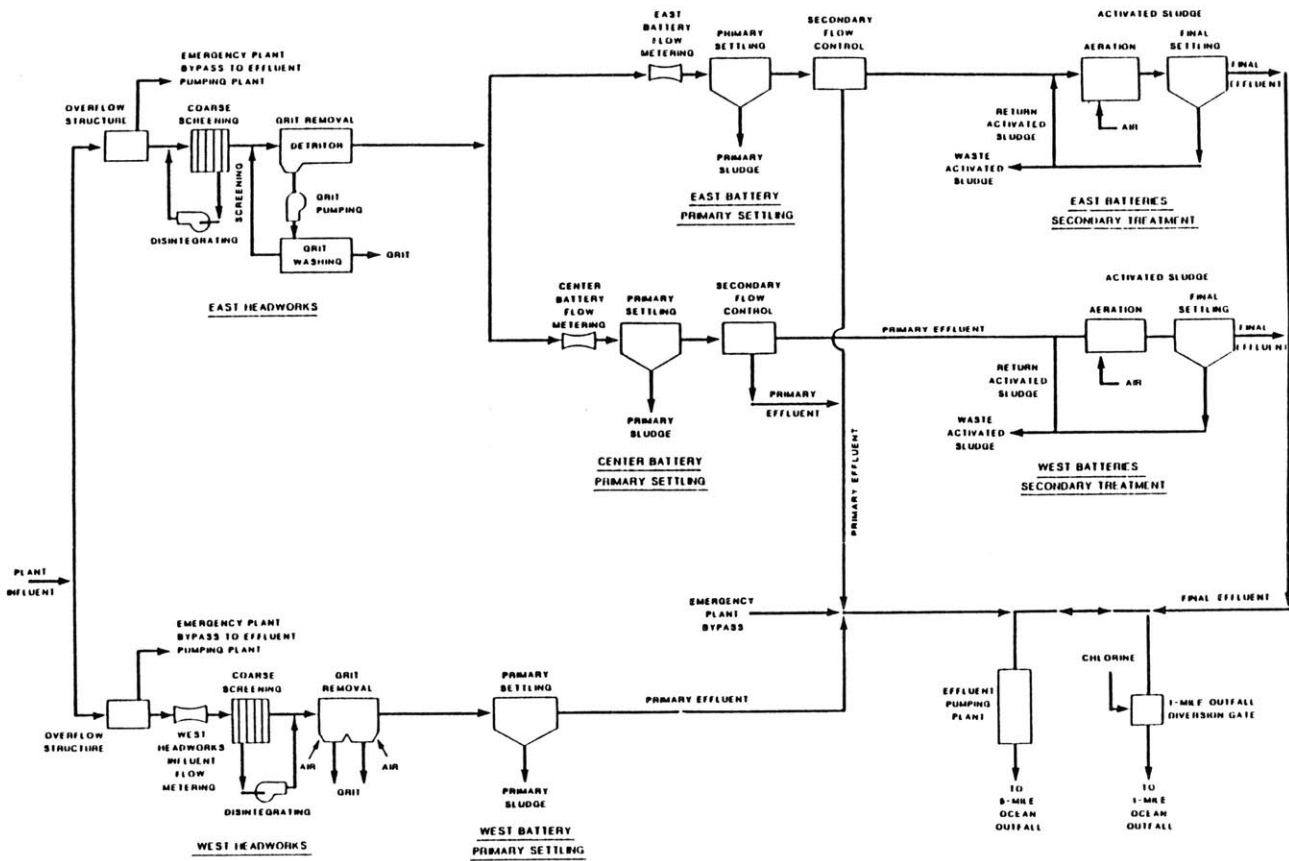
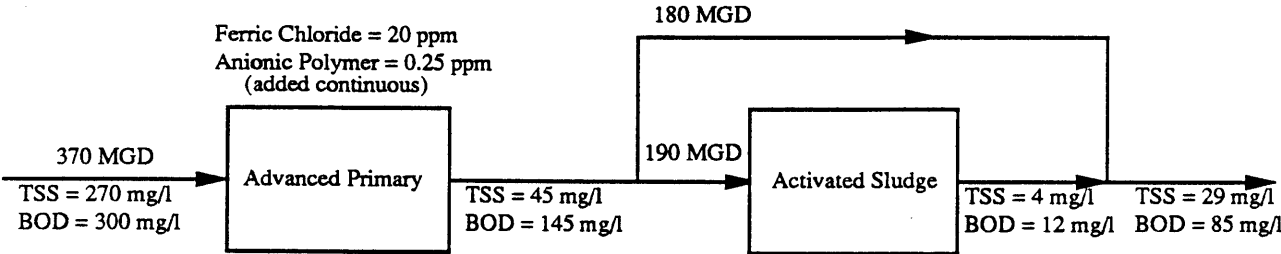

Figure 2.8: Process Diagram of the Hyperion Wastewater Plant, City of Los Angeles (Shao, 1989)

City of Los Angeles Treatment Facility

Hyperion



Advanced Primary only:
 Removal rate of TSS = 83%
 Removal rate of BOD = 52%

Overall Removals:
 Removal rate of TSS = 89%
 Removal rate of BOD = 72%

Activated Sludge only:
 Removal rate of TSS = 91%
 Removal rate of BOD = 92%

Advanced Primary plus Activated Sludge:
 Removal rate of TSS = 99%
 Removal rate of BOD = 96%

Figure 2.9: Flow Diagram of the Hyperion Wastewater Plant, City of Los Angeles

and 85 mg/l respectively. Effluent is discharged from Hyperion into the ocean through an outfall (equipped with 4,000 ft diffusers) approximately 26,400 ft long at a depth of 320 ft.

To enhance settling, Hyperion adds approximately 20 mg/l of FeCl_3 and 0.25 mg/l of an anionic polymer to the raw wastewater entering the plant. The addition of chemicals to enhance settling has resulted in the following:

- Removal rates of 83%, 52%, and about 80% for TSS, BOD_5 , and total phosphorus respectively from the advanced primary portion of the plant.
- Average overflow rates for the primary clarifiers are greater than 1900 gpd/ft².
- Load on the biological secondary facility has been doubled over the past few years primarily as a result of advanced primary treatment.

The City of Los Angeles is currently under contract with a consulting firm to provide a facility plan that meets the needs of the city and EPA requirements for full secondary treatment. The plan is expected to consist of a secondary biological facility and a number of water reclamation facilities. The reclamation sites are already in place. The full biological secondary facilities plan will require demolishing the existing conventional biological secondary plant (which is working at twice the design flow primarily because of the advanced primary treatment) and construct a 550 mgd high purity oxygen plant without utilizing the added benefits gained from chemically-enhanced settling. This project is being designed for a flow of 550 mgd at a cost of approximately \$1.6 billion in 1990 dollars.

It seems reasonable that the city of Los Angeles should use chemicals in the designed conventional primary plant. This would allow a sizing down of the primary sedimentation tanks and a reduction in the size of the secondary treatment facility due to the reduction in the size of the organic matter that the bacteria will have to break-down.

A more reasonable alternative would be to leave the existing conventional activated sludge system in place and construct flocculation basins to optimize removals in the primary sedimentation tanks. These flocculation basins could be built at a fraction of the cost and provide essentially the same removal efficiency. If additional treatment is required, an activated sludge or a bio-filter system could be built at a fraction of the initial size required.

2.2.5 North End Plant - Tacoma, Washington

The City of Tacoma, servicing 45 thousand, currently treats an average of 5 mgd of wastewater at the North End treatment plant. All of the flow entering the plant receives chemical treatment. The plant consists of bar screens, aerated grit chambers, primary sedimentation tanks, sludge digesters, chlorine contact basin, and an ocean outfall (Figure 2.10). The average TSS and BOD₅ influent concentration is 166 mg/l and 163 mg/l respectively (Figure 2.11). The average TSS and BOD₅ effluent concentration is 7 mg/l and 25 mg/l respectively. Effluent is discharged from the North End plant into the ocean through an outfall (without diffusers) approximately 720 ft offshore at a depth of 85 ft.

To enhance settling, Tacoma adds approximately 162 mg/l of alum and 2.8 mg/l of a cationic polymer to the raw wastewater entering the plant. The addition of chemicals to enhance settling has resulted in removal rates of 96%, 85%, and 90% for TSS, BOD₅, and total phosphorus respectively.

Tacoma was ordered by the Washington State Department of Ecology to provide full secondary treatment by February 1, 1991. They were given a grant for \$28 million to construct a high purity oxygen biological secondary facility. It was decided that the money would be returned and that they would achieve secondary treatment standards with chemicals. Currently, Tacoma is meeting the requirements for secondary treatment. This is being accomplished within their existing facility. In the future, Tacoma plans to construct flocculation basins to optimize the chemical addition process, lower the concentrations of chemical, and consider FeCl₃ as an alternative to alum.

2.2.6 Sarnia Treatment Plant - Sarnia, Ontario Canada

The City of Sarnia currently treats an average of 9.5 mgd of wastewater at their treatment plant. All of the flow entering the plant receives chemical treatment. The plant consists of bar screens, grit chamber, pre-aeration tanks, primary sedimentation tanks, sludge digesters, and an outfall (Figure 2.12). The average TSS and BOD₅ influent concentration is 150 mg/l and 150 mg/l respectively (Figure 2.13). The average TSS and BOD₅ effluent concentration is 24 mg/l and 60 mg/l respectively.

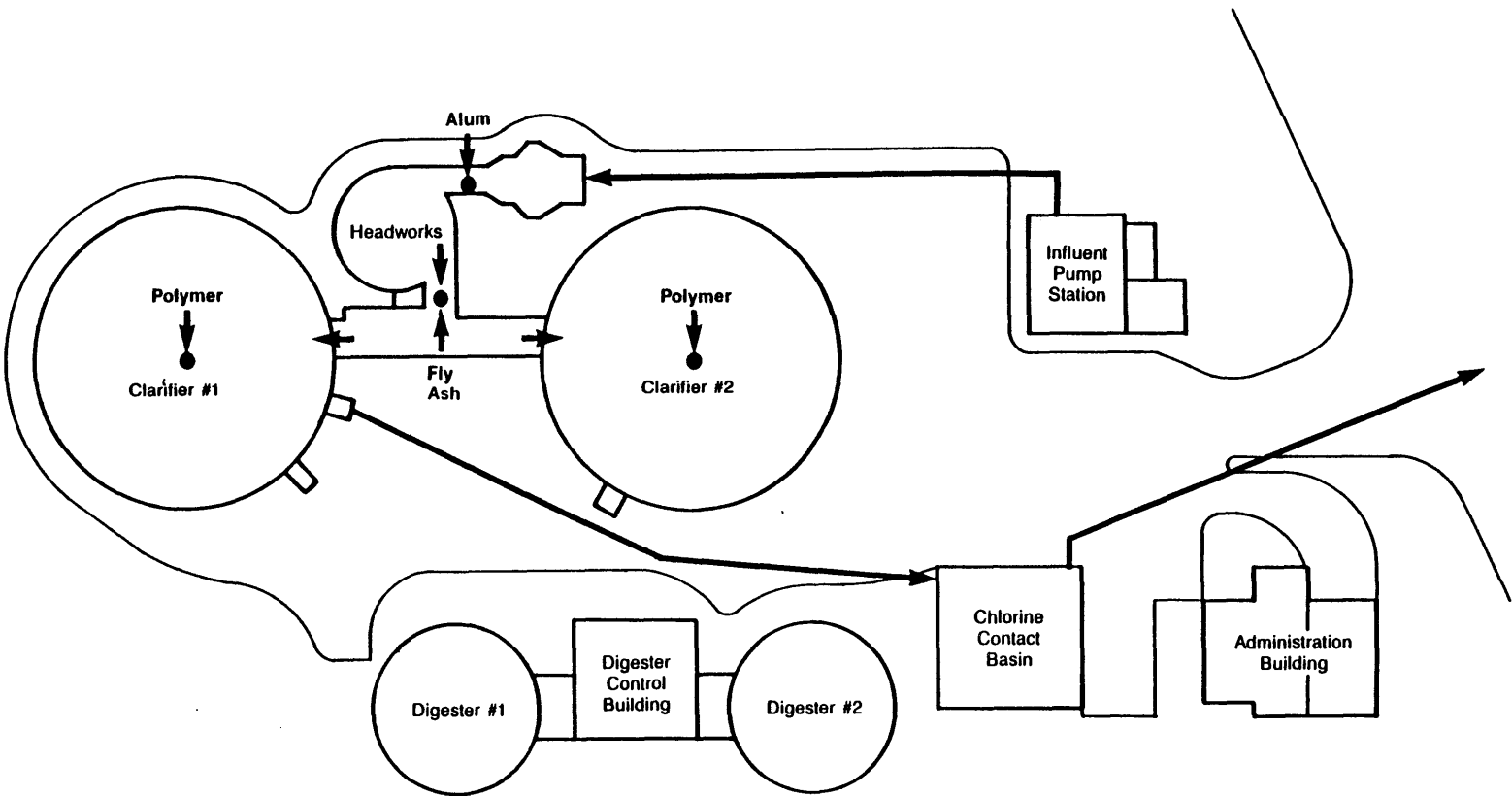
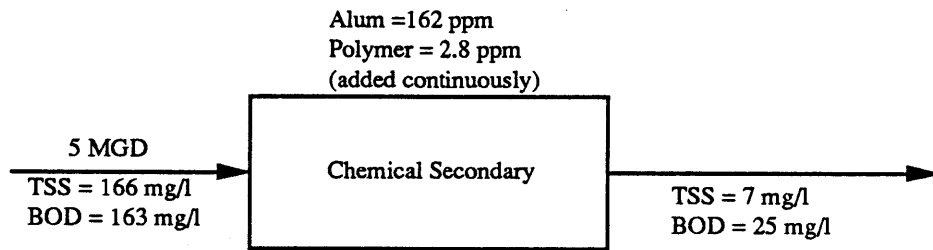

Figure 2.10: Site Plan of the North End Treatment Plant, Tacoma, Washington (Capestany, 1989)

Tacoma, Washington Treatment Facility



Chemical Secondary only:
Removal rate of TSS = 96%
Removal rate of BOD = 85%

Figure 2.11: Flow Diagram of the North End Treatment Plant, Tacoma, Washington

Figure 2.12: Site Plan of the Sarnia Treatment Plant (Burns, 1989)

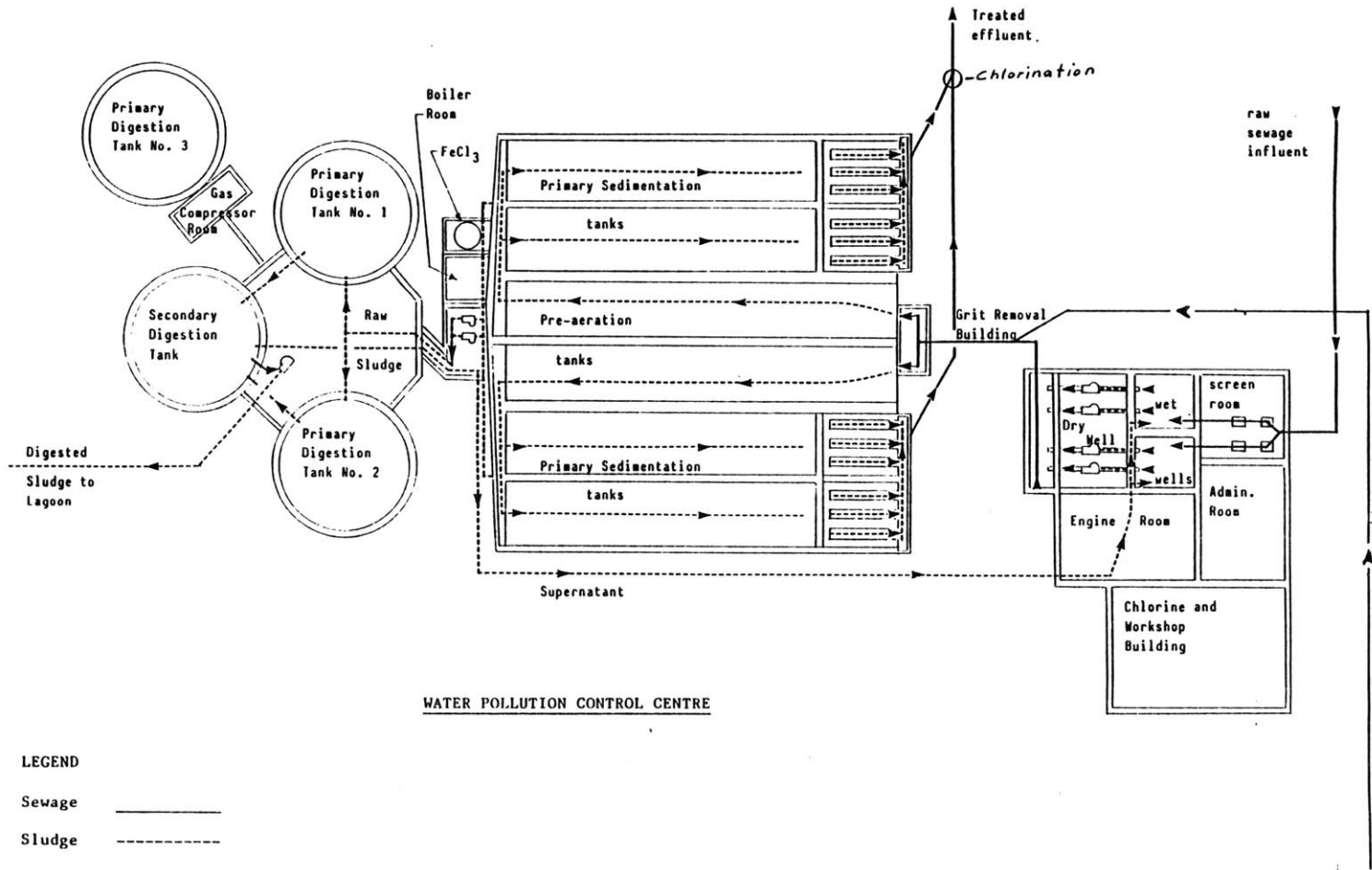

Sarnia, Ontario Canada Treatment Facility

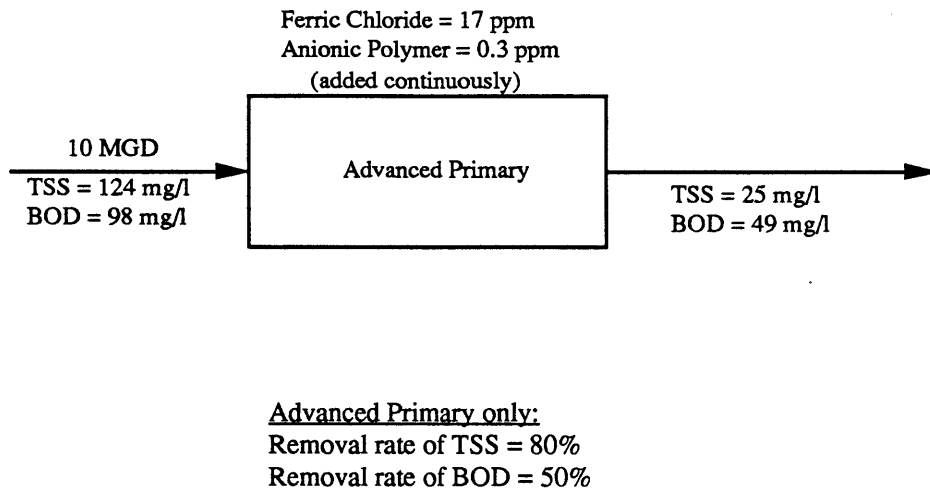

Figure 2.13: Flow Diagram of the Sarnia Treatment Plant

To enhance settling, Sarnia adds approximately 14 mg/l of FeCl_3 and 0.3 mg/l of an anionic polymer to the raw wastewater entering the plant. The addition of chemicals to enhance settling has resulted in the following:

- Removal rates of 84%, 60%, and 85% for TSS, BOD_5 , and total phosphorus respectively.
- Overflow rates of greater than 2000 gpd/ft² can be used without deteriorating the performance of the plant (Heinke, et al., 1983).

The City of Sarnia wastewater treatment plant is located on Lake Ontario. The driving force behind the addition of chemicals at the Sarnia plant is to control phosphorus releases into the lake. If Sarnia was required to obtain higher BOD_5 removal, this could be accomplished by adding a flocculation basin after the pre-aeration tanks and before the sedimentation tanks.

2.2.6 Montreal Urban Community Wastewater Treatment Plant - Montreal, Quebec Canada

The City of Montreal currently treats an average of 250 mgd of wastewater at their treatment plant. All of the flow entering the plant receives chemical treatment. The plant consists of bar screens, aerated grit chambers, aeration influent channels, primary sedimentation tanks, disinfection, and incinerators (Figure 2.14). The average TSS and BOD_5 influent concentration is 108 mg/l and 50 mg/l respectively (Figure 2.15). The average TSS and BOD_5 effluent concentration is 21 mg/l and 24 mg/l respectively.

To enhance settling, Montreal adds approximately 32 mg/l of FeCl_3 and 0.35 mg/l of an anionic polymer to the raw wastewater entering the plant. The addition of chemicals to enhance settling has resulted in removal rates of 81%, 52%, and 76% for TSS, BOD_5 , and total phosphorus respectively.

Montreal's urban community wastewater treatment plant is unique in that they have developed a pilot plant that simulates the performance of the actual plants. This pilot plant has been used to optimize chemical concentrations and to redesign physical aspects of the plant. They have found the pilot plant to be a cost effective investment.

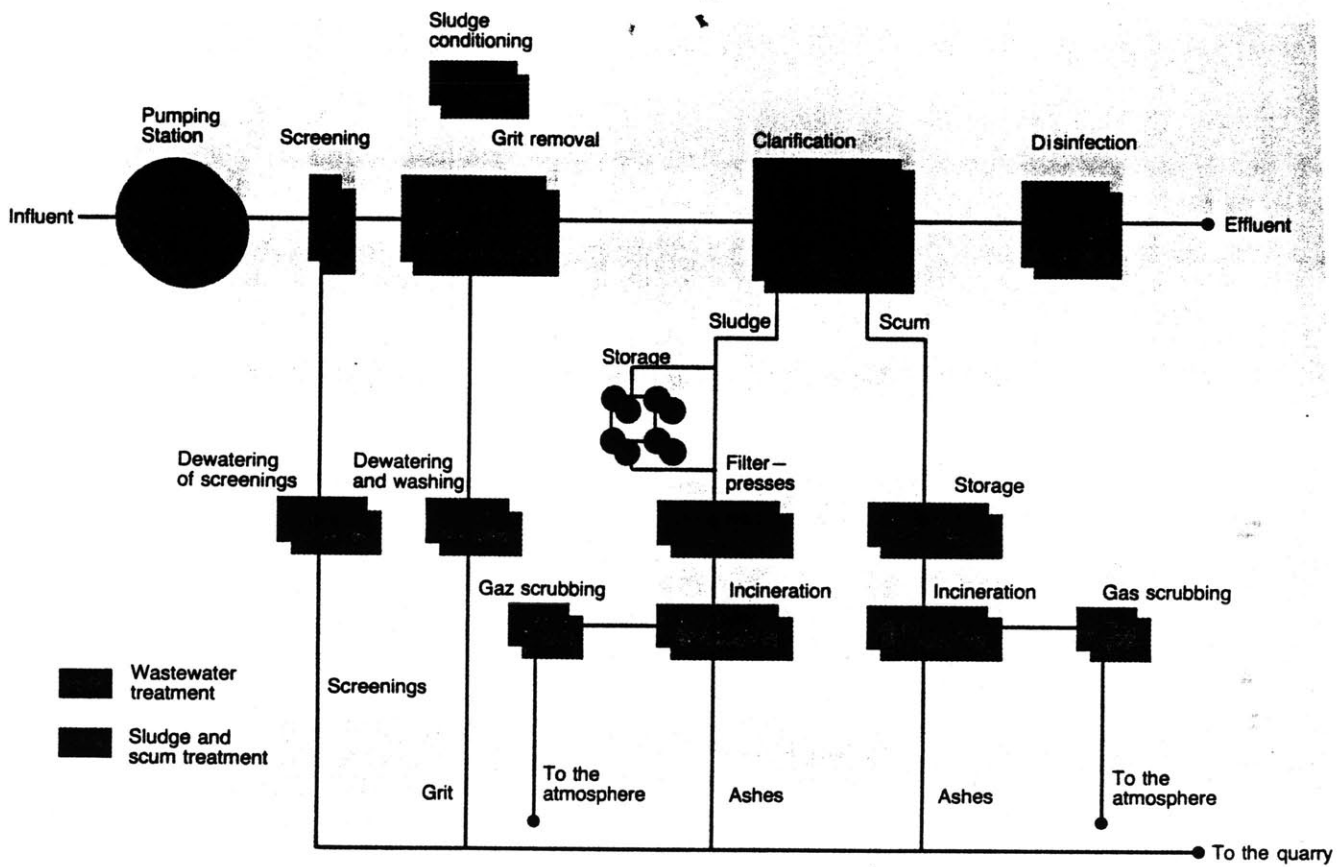
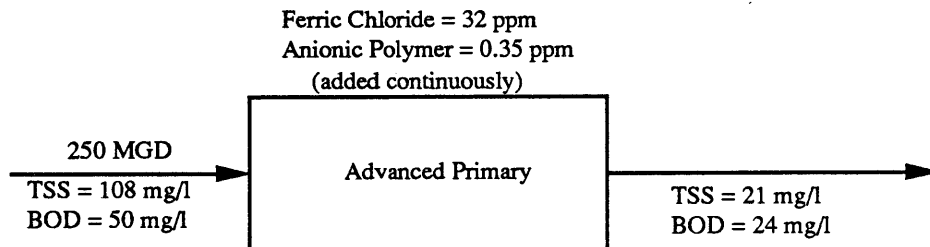

Figure 2.14: Process Diagram of the Montreal Urban Community Treatment Plant (Purenne, 1989)

Montreal Urban Community Treatment Plant, Quebec



Advanced Primary only:
Removal rate of TSS = 81%
Removal rate of BOD = 52%

Figure 2.15: Flow Diagram of the Montreal Urban Community Treatment Plant

2.3 Scandinavian Plants

Approximately 90% of all wastewater treatment facilities in Scandinavia are currently adding chemicals to enhance settling. Chemicals were initially used to optimize the total phosphorus removal. Chemical addition has also proven to be beneficial in the operating process, obtains better removal rates for all pollutants not only P, and is extremely cost effective.

There are essentially four treatment processes that are employed that use chemicals: direct precipitation (chemical secondary), secondary precipitation (an additional clarifier before a direct precipitation plant), direct precipitation with biological secondary, and post precipitation after biological secondary (tertiary).

The chemical secondary (direct precipitation) process includes bar screens, grit chambers, flocculation basins, and sedimentation tanks (Figure 2.16a). There is no subsequent biological treatment. Data from Norway (Odegaard, 1988), indicates that this type of process can consistently obtain removal rates greater than 85% for TSS, 80% for BOD₅, and 90% for total phosphorus (Table 2.1).

Table 2.1: 1985 Average Treatment Results for 23 Direct Precipitation Plants in Norway

	Influent (mg/l)	Effluent (mg/l)	Removal Rate (%)
TSS	172	27	84
BOD	216	42	81
Total P	5.5	0.5	90

Source: Odegaard 1989

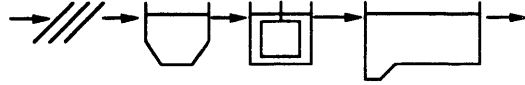

Figure 2.16a: Direct Precipitation (Chemical Secondary)

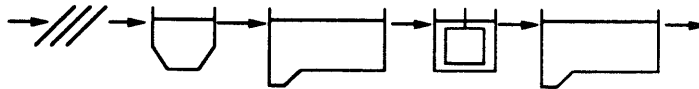

Figure 2.16b: Secondary Precipitation (A Clarifier Before Direct Precipitation)

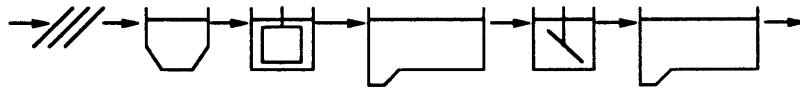

Figure 2.16c: Direct Precipitation With Biological Secondary

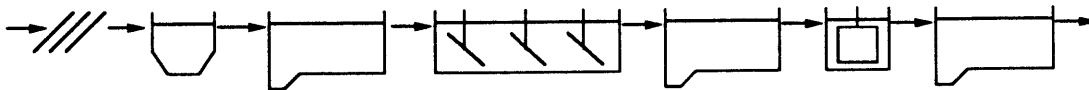

Figure 2.16d: Post Precipitation After Biological Secondary (Tertiary)

Figure 2.16: Various Scandinavian Chemical Treatment Processes

An example of a large facility using direct precipitation (chemical secondary) is the treatment plant in Oslo, Norway. This plant includes bar screens, grit chambers, flocculation basins, sedimentation tanks, sludge thickeners, belt filter presses, and an outfall (Figure 2.17). The average daily flow into the Oslo plant is approximately 80 mgd with a peak flow of 160 mgd. The average TSS, BOD₅, and total phosphorus influent concentration is 120 mg/l, 140 mg/l, and 3.5 mg/l respectively (Figure 2.18). The average TSS, BOD₅, and total phosphorus effluent concentration is 10 mg/l, 30 mg/l, and 0.2 mg/l respectively. To enhanced settling, Oslo adds approximately 150 mg/l of FeCl₃, 0.2 mg/l of an anionic polymer, and seawater at 3% of the plants flow to the raw wastewater entering the plant. The addition of chemicals to enhance settling has resulted in the following:

- Removal rates of 92%, 85%, and 95% for TSS, BOD₅, and total phosphorus respectively.
- Overflow rates of greater than 2500 gpd/ft² can be used without deteriorating the performance of the plant.
- A significant reduction in capital cost to obtain these removal rates.
- Sludge dewaterers to 35% dry solids.

Secondary precipitation is accomplished by adding an additional set of sedimentation tanks before the flocculation basins and after the grit chambers (Figure 2.16b). There is no subsequent biological treatment. Data from Norway (Odegaard, 1988), indicates that this type of process can consistently obtain removal rates greater than 90% for TSS, 85% for BOD₅, and 93% for total phosphorus (Table 2.1). This method has proven to be less cost effective than direct precipitation.

Pre-precipitation with biological secondary is accomplished using the same process as in direct precipitation but followed by a biological treatment process (Figure 2.16c). The two major advantages of this process over the traditional secondary treatment facility are 1) that the size of the biological treatment facility can be reduced significantly by optimizing the removal efficiency in the primary sedimentation tanks, and 2) any additional tankage from an existing biological plant not needed for BOD₅ removal can be used to control nitrogen releases. This will be discussed in more detail in Chapter 4.

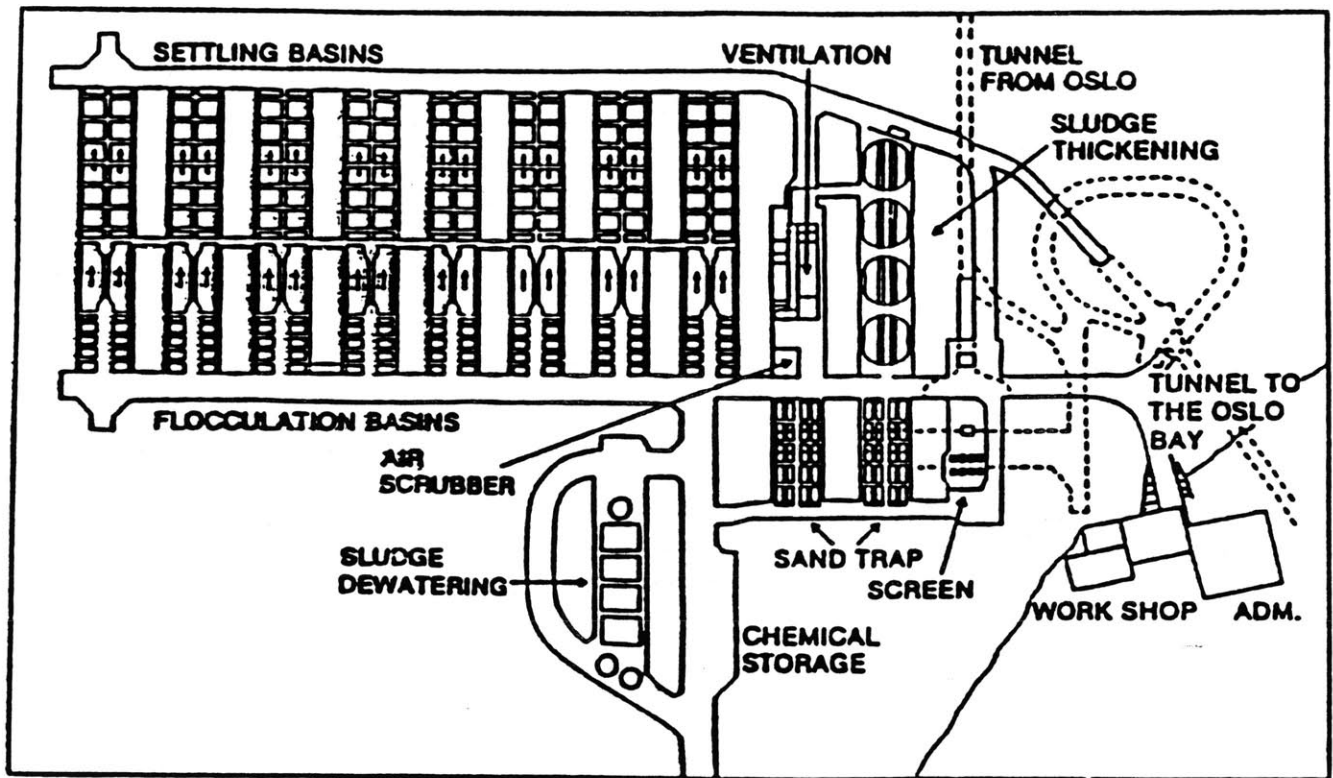
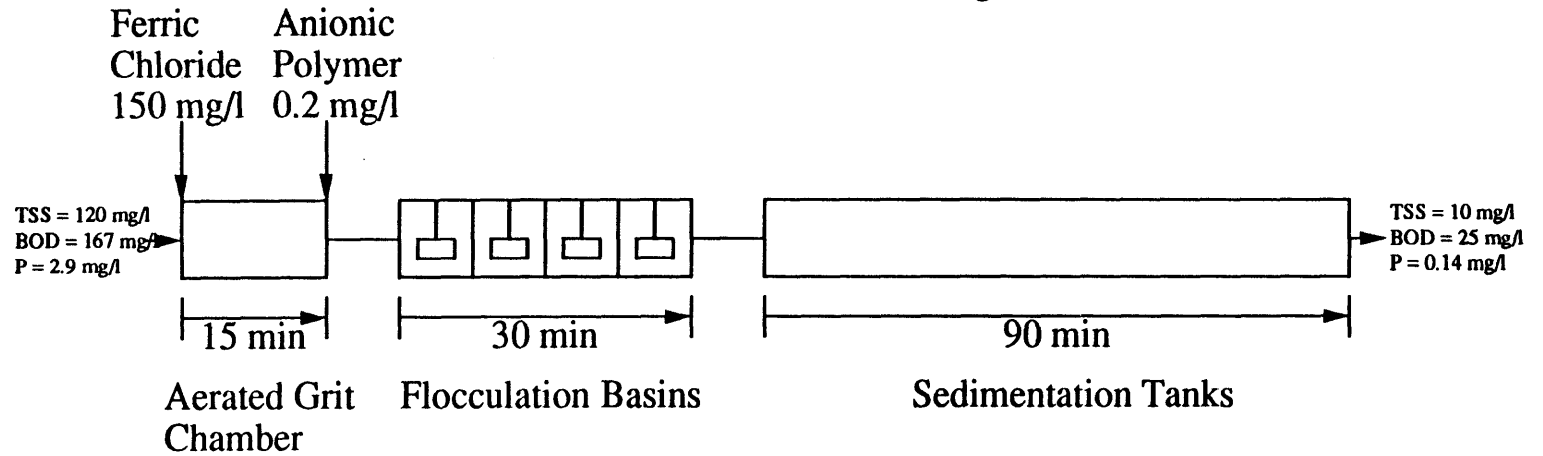

Figure 2.17: Process Diagram of the Oslo Treatment Plant (Sagberg, 1989)

Oslo (VEAS) Treatment Plant

Dry Weather Flow = 80 mgd
Wet Weather Flow = 160 mgd



Overall Removal Efficiency:

TSS = 92%
BOD = 85%
P = 95%

Figure 2.18: Flow Diagram of the Oslo Treatment Plant

Post precipitation after biological secondary is often called tertiary treatment (Figure 2.16d). This process produces high quality effluent; however, it is difficult to operate and is cost intensive. The unfortunate aspect of tertiary treatment is that it does not optimize removal efficiencies in the beginning of the treatment. It is believed that if this type of plant was to be converted to a pre-precipitation and biological secondary plant, the additional tanks could be used to control nitrogen releases (Karlsson, 1988).

Chapter 3
CHEMICAL ADDITION AT SOUTH ESSEX SEWERAGE DISTRICT
(SESD) PRIMARY TREATMENT PLANT: A CASE STUDY

3.1 Introduction

There has been a series of jar tests and full scale chemical addition tests at SESD. The purpose of these tests was to determine if the addition of chemicals to the wastewater could improve SESD's effluent quality and to comply with a court imposed interim partial consent order (U.S. District Court, December 1989).

The interim partial consent order states the following in regard to chemical addition studies at SESD:

"SESD shall conduct an evaluation of the effects on treatment plant removal efficiency from feeding various chemicals into the primary clarifiers influent for the purpose of determining whether chemical addition will improve plant performance for removal of biochemical oxygen demand and total suspended solids for the period of time prior to completion of secondary treatment facilities. This evaluation shall include:

(a) a bench scale study using jar tests of chemicals added to primary influent. The chemicals to be evaluated shall include lime, alum, ferric chloride, lime and polymer, alum and polymer, ferric chloride and polymer, and polymer alone.

SESD shall study a concentration range of these chemicals designed to fully evaluate their efficacy. The polymers to be evaluated should be selected based on manufacturers' recommendations as to applicability. At least three polymers should be evaluated for use with each coagulant, and each polymer should be evaluated alone as well. Jar test results should be evaluated based on supernatant TSS levels.

The results of the bench scale study shall be submitted to EPA and DEP on or before February 15, 1990.

(b) a full scale evaluation of the most promising chemical addition regime through application at the plant. The results on the full scale evaluation shall be submitted to EPA and DEP on or before May 1, 1990."

What follows is a description of SESD's primary treatment facility and a discussion of the various tests conducted using chemical addition.

3.1.1 Description of SESD's Primary Treatment Plant

SESD's treatment plant is located 15 miles north of Boston in Essex County (Figure 3.1 and 3.2). The plant serves approximately 161,000 people from the following five communities: Marblehead, Beverly, Danvers, Salem, and Peabody and a number of small sources outside these communities. The yearly average flow is 26 million gallons per day (mgd) with a maximum average daily flow of 53 mgd and a minimum average daily flow of 14 mgd (Morrissey and Harleman, February 1990). SESD provides primary treatment and sludge disposal.

The primary treatment facility receives screened wastewater that flows through aerated grit chambers to a series of sedimentation tanks (Figure 3.3). The effluent from the sedimentation tanks is disinfected with sodium hypochlorite before being released into the ocean. Flow is monitored at the effluent pumping station. The flow meter is calibrated to a maximum flow of 55 mgd and a minimum flow of 5 mgd. Flow is also monitored at each of the influent pumping stations for billing purposes. The by-product from the primary treatment process (sludge) is processed by mixing it with portland cement and a silica reagent (referred to as chemical fixation) and is disposed of as a landfill cover in Peabody.

The facility is designed so that the wastestream can be combined or separated into a primarily domestic flow and a more industrial flow. Whether the flow is combined or separated, it is split and the plant runs as two distinct and parallel treatment facilities until the effluents are combined before being discharged into the ocean. Although SESD flow is split evenly, the two sides of the plant are not totally symmetric.

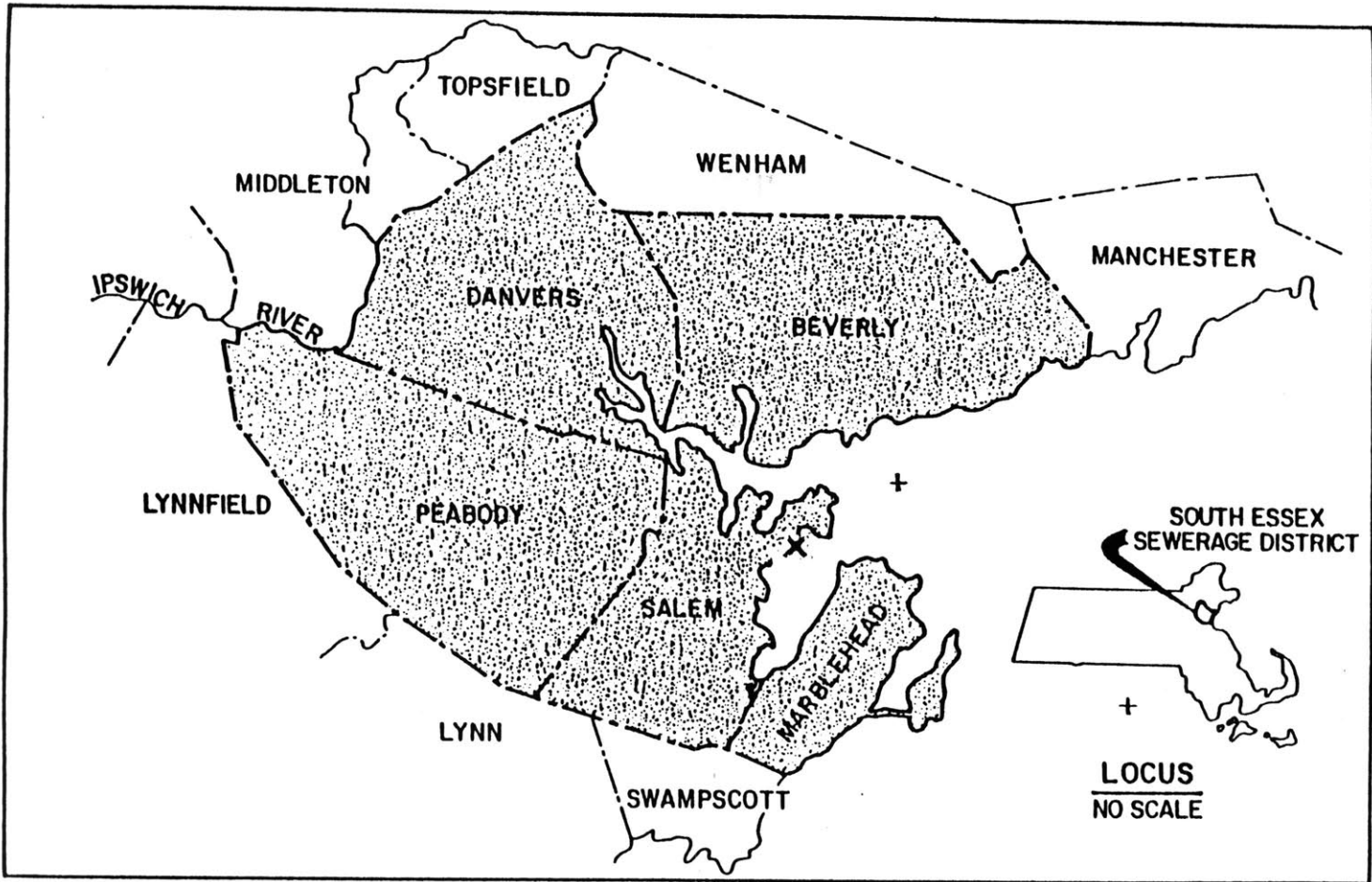

Figure 3.1: Location of the South Essex Sewerage District (CDM, 1988)

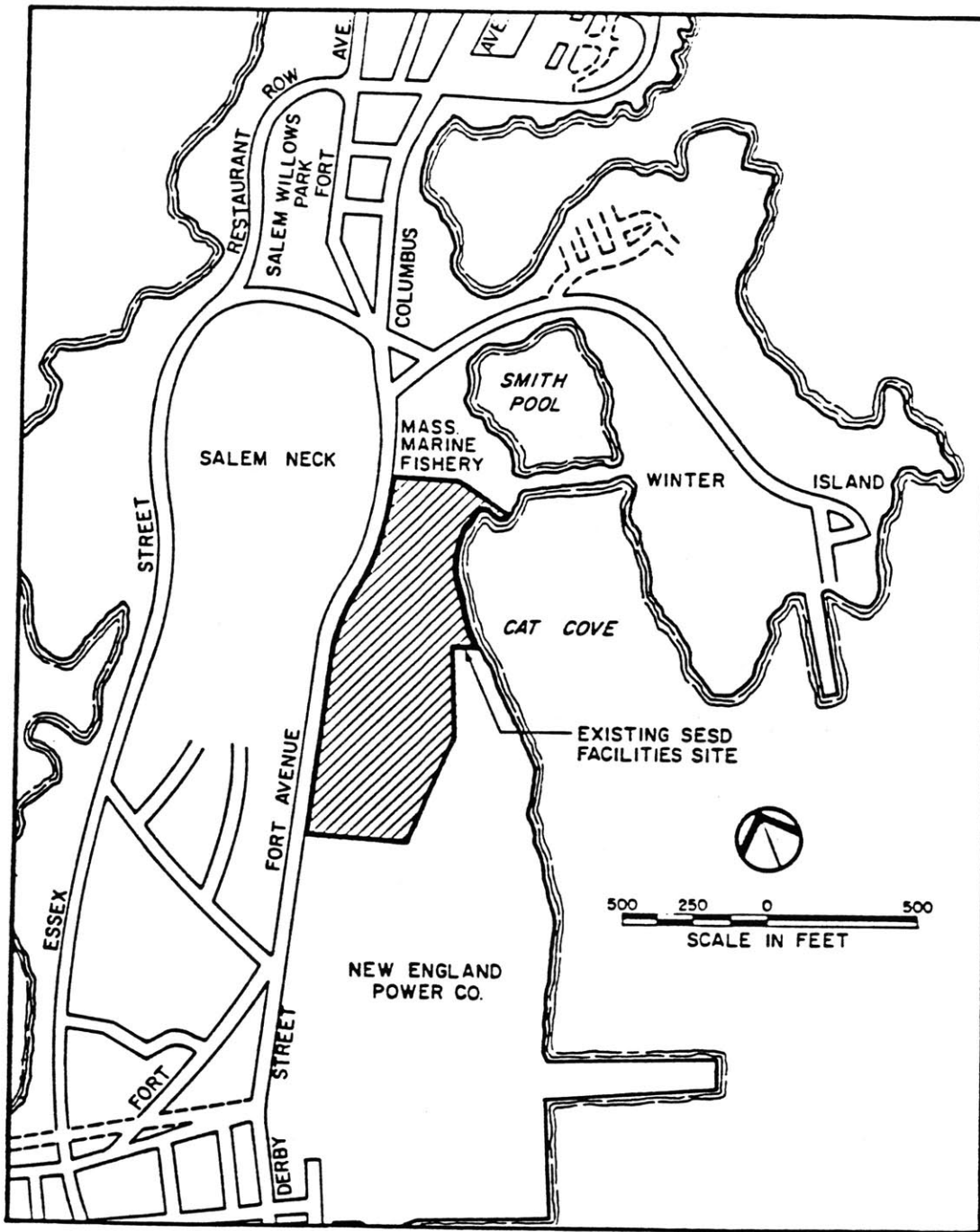

Figure 3.2: Site Location of the SESD Facility (CDM, 1988)

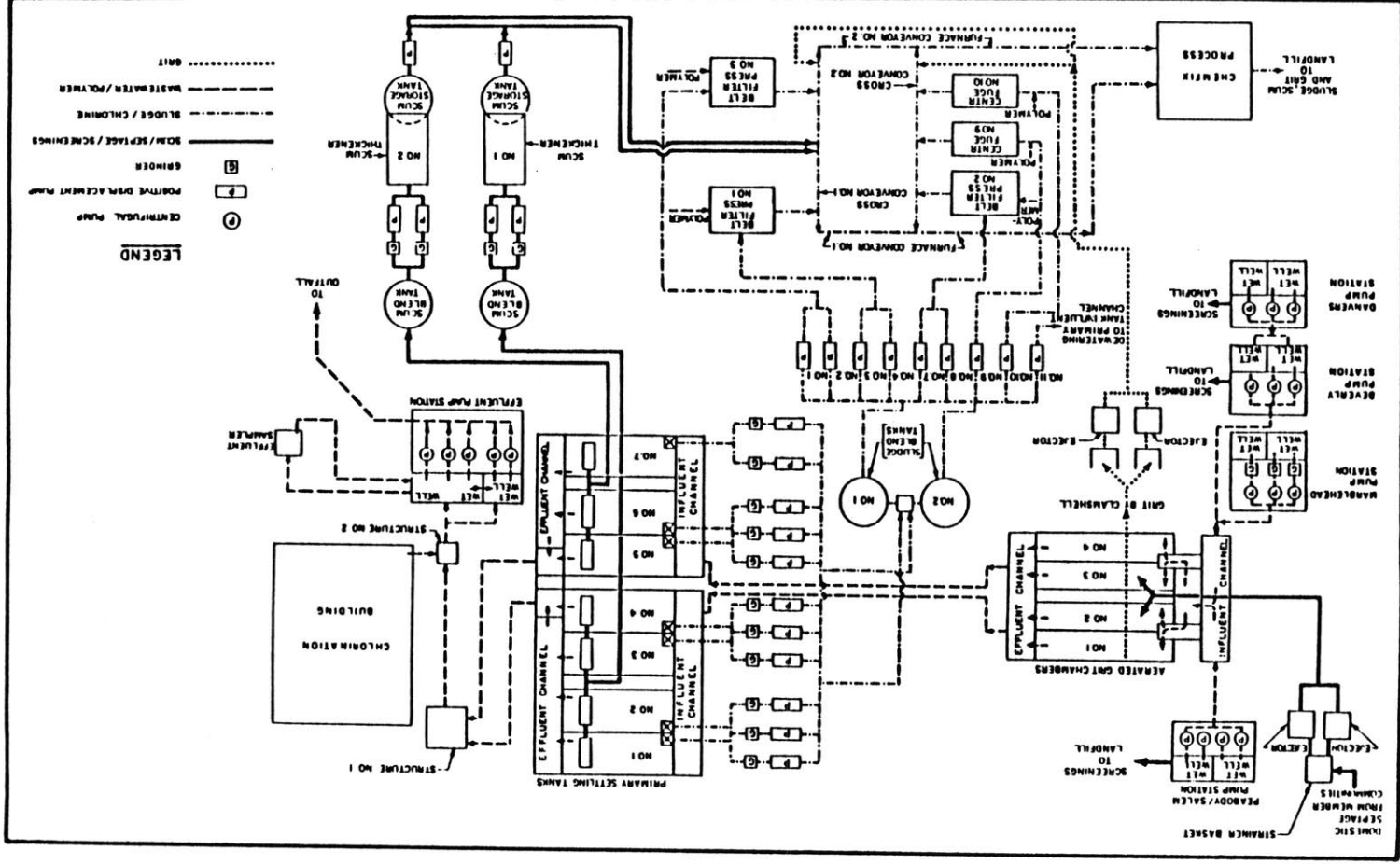

Figure 3.3: Process Diagram for SEDD

Once the flow enters the treatment plant (Figure 3.4), it is combined and split before entering aerated grit chambers. Each side has two grit chambers with at least one operational at all times. The grit chambers on the eastern side are 54.5' long, 14' wide, and 10.3' deep with a total volume of 7,860 ft³ or 58,800 gallons. The grit chambers on the western side are 59.5' long, 14' wide, and 10.4' deep with a total volume of 8700 ft³ or 64,800 gallons. Table 3.1 shows retention times for various flows associated with each aspect of the treatment facility. All of the grit chambers are constructed of concrete with a metal lip that forms a sharp-crested outlet weir. The air pumped into the grit chamber causes the liquid to form a helical flow pattern. Flow travels over the outlet weir into two separate channels with an outlet conduit in the middle. The flow drops approximately two feet into these channels, which causes a great amount of turbulence and air entrainment.

Once the separated flow leaves the channels below the weirs, it travels down 4'x5'x23' conduits, through 235' long and 5' diameter horizontal conduits, and then up 4'x5'x21' conduits to aerated influent channels. These aerated influent channels allow the flow to stabilize before entering the sedimentation tanks. The aerated influent channel on the eastern side is 4'x5'x116' and distributes flow into three sedimentation tanks. The aerated influent channel on the western side is 4'x5'x148' and distributes flow into four sedimentation tanks.

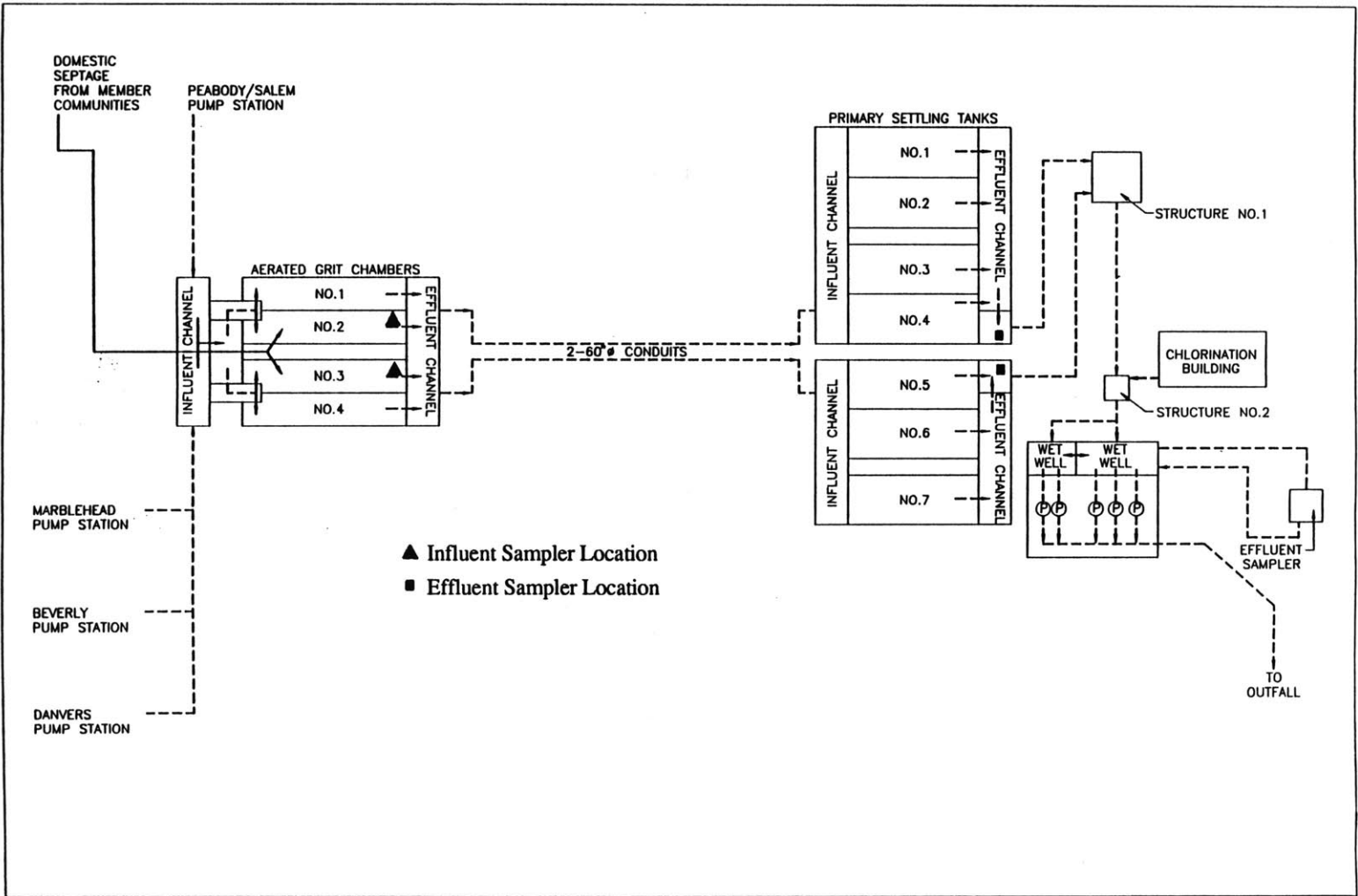

Figure 3.4: Liquid Process Diagram for SEDS (Tighe & Bond, June, 1990)

Table 3.1: Retention Times Associated With Half of the Total Flow Through
SESD's Treatment Plant

	FLOW					
	8 mgd	10 mgd	12 mgd	14 mgd	16 mgd	20 mgd
			~ design flow			
Grit Chamber 54.5'x14'x 10.3'	10.6 min	8.5 min	7.0 min	6.0 min	5.3 min	4.3 min
Grit Chamber 59.5'x14'x 10.4'	11.7 min	9.3 min	7.8 min	6.7 min	5.8 min	4.6 min
Vert. Conduit 4'x5'x23'	.62 min	.50 min	.41 min	.35 min	.31 min	.25 min
Hort. Conduit 235' dia 5'	6.2 min	5.0 min	4.1 min	3.6 min	3.1 min	2.5 min
Vert. Conduit 4'x5'x21'	.57 min	.45 min	.38 min	.32 min	.28 min	.23 min
Aerated Channel 4'x5'x116'	3.1 min	2.5 min	2.1 min	1.8 min	1.6 min	1.3 min
Aerated Channel 4'x5'x148'	4.0 min	3.2 min	2.7 min	2.3 min	2.0 min	1.6 min
Sed Tanks 2 @245'x32'x 12.5'	4.4 hr	3.5 hr	2.9 hr	2.5 hr	2.2 hr	1.8 hr
Sed Tanks 3 @245'x32'x 12.5'	6.6 hr	5.3 hr	4.4 hr	3.8 hr	3.3 hr	2.6 hr
Sed Tanks 4 @245'x32'x 12.5'	8.8 hr	7.0 hr	5.8 hr	5.0 hr	4.4 hr	3.5 hr

Each of the seven sedimentation tanks are 245' long, 32' wide, and 12.4' deep with a surface area of 7840 ft² and a volume of 97,200 ft³ or 727,000 gallons. Table 3.2 shows overflow rates for various flows. There are four gates for each tank, which can be adjusted to any height, in order to regulate flow into the sedimentation tanks. At each gate, there is a timber baffle that causes the flow to be dispersed evenly throughout the upstream end of the tanks. The tanks are equipped with racks carrying the sludge to the upstream end of the

tank into a channel that leads into a sump for removal. At the downstream end of these tanks, the scum is collected and diverted to a central location. The effluent from a tank is collected over an H-shaped weir into a central channel. The effluent from each side of the plant is then combined before being discharged into the ocean.

Table 3.2: Overflow Rates (gpd/ft²) Associated With Half of the Total Flow Through SESD's Treatment Plant

	FLOW					
	8 mgd	10 mgd	12 mgd	14 mgd	16 mgd	20 mgd
			~ design flow			
1 tank	1020	1280	1530	1790	2040	2550
2 tanks	510	640	770	890	1020	1280
3 tanks	340	430	510	600	680	850
4 tanks	255	320	380	450	510	640

Sludge from each side of the plant is collected into separate bins that each hold 150,000 gallons of wet sludge. The sludge from each bin can be processed independently. The process procedure for SESD is as follows: add polymers to aid in dewatering, dewater using belt presses, mix sludge with grit, scum, and portland cement, add reagents to raise the pH to approximately 12, and then dispose of the chemically fixed sludge as a landfill cover in Peabody.

A detailed analysis of SESD's conventional primary treatment plant performance during the one year period from October 1988 through September 1989 was done (Morrissey and Harleman, February 1990) and the following conclusions were drawn:

- There is a high variability in the flow, loading, and treatment efficiency at SESD.
- There is a lack of expected correlation between treatment efficiency, influent characteristics, and retention times (overflow rate).
- There is a need to measure the chemically treated and untreated sides simultaneously throughout the chemical enhancement testing period. Only in this way can the benefits of chemical treatment be established.
- Yearly average removal rates for TSS and BOD₅ are 57% and 24% respectively under conventional treatment.

3.1.2 Tests Conducted at SESD

To date, five quantitative jar tests (three by Delta Chemicals Inc. and two by Tighe & Bond Inc.) and four full scale tests have been conducted at SESD. The jar testing was conducted for the following reasons:

- To determine the proper order of chemical addition, a range of chemical concentrations, and the chemical manufacturer who could supply SESD with the most effective chemicals.
- To fulfill a consent decree by the court.
- To establish a correlation between the jar test and plant performance.

The full scale tests were conducted for the following reasons:

- To determine the proper chemical concentration, chemical feed locations, sludge dewatering properties, and characteristics of the operating facilities with-respect-to chemical addition.
- To fulfill a consent decree by the court to evaluate this process.

Specific sections in this chapter will be devoted to jar tests, full scale tests, results and comparisons of the tests, and recommendations for further testing.

3.2 Jar Test Studies

Five quantitative jar tests were conducted at SESD. Three of these tests were conducted by Delta Chemicals, Inc. (referred to as Delta). The purpose of these jar tests was three-fold:

- To determine whether TSS and BOD₅ removal rates at SESD could be significantly improved through the use of chemical addition.
- To determine the proper sequence in which to add these chemicals to obtain the best overall performance.
- To determine a range of chemical concentrations necessary to improve removal efficiency.

The last two jar tests conducted at SESD were done by Tighe & Bond, Inc. (referred to as Tighe & Bond). The purpose of these tests was:

- To fulfill SESD's Interim Partial Consent Decree.
- To design a jar test that would closely match the plant's performance.

The part of the Interim Partial Consent Decree that addresses jar testing is summarized below:

- Run jar tests of chemical addition to SESD's primary influent.
- Test a range of metal salts (alum, lime, and ferric chloride) and polymers in combination and alone.
- Polymers tested must be from at least three different manufacturers.
- Evaluate tests based on supernatant TSS levels.

Tighe & Bond conducted the first study from January 16-23, 1990 and published a report (Tighe & Bond, February 1990). The second jar test conducted by Tighe & Bond was done during the fourth full scale test from March 25 to April 15, 1990. These jar tests were conducted to match the jar testing procedure to the plant's performance.

3.2.1 Jar Testing by Delta Chemical, Inc.

Three quantitative jar tests were conducted by Delta at SESD. The dates of these tests were October 10, 1989, October 24, 1989, and December 5, 1989. Delta supplied the chemicals for all three tests. The chemicals used during the tests were FeCl_3 , alum, anionic polymer (2540), and cationic polymer (4000 numbers). The results from each of the tests are given below in Table 3.3, 3.4, and 3.5. All samples were analyzed at Belfast Technical Service Laboratories, Belfast, Maine. Note that there is a large discrepancy especially in BOD removal rates in duplicate tests performed at different times.

Table 3.3: Results of Jar Testing by Delta at SESD on October 10, 1989

Chemical Sequence and Concentration	TSS Concentration (mg/l)	TSS Removal Rate (%)	BOD ₅ Concentration (mg/l)	BOD ₅ Removal Rate (%)
5 ppm 4601 15 ppm FeCl ₃ 0.3 ppm 2540	12	86	40	73
5 ppm 4701 15 ppm FeCl ₃ 0.3 ppm 2540	6	93	44	71
5 ppm 4801 15 ppm FeCl ₃ 0.3 ppm 2540	8	91	37	75
5 ppm 4901 15 ppm FeCl ₃ 0.3 ppm 2540	12	86	43	71
5 ppm 4701 15 ppm FeCl ₃ 0.5 ppm 2540	36	59	34	77

Note: The raw influent sample consisted of 88 mg/l TSS and 150 mg/l BOD₅.
All samples were taken as the flow enters the aerated grit chamber.

Table 3.4: Results of Jar Testing by Delta at SESD on October 24, 1989

Chemical Sequence and Concentration	TSS Concentration (mg/l)	TSS Removal Rate (%)	BOD ₅ Concentration (mg/l)	BOD ₅ Removal Rate (%)
3 ppm 4701 12 ppm FeCl ₃ 0.2 ppm 3540	5.5	93	22	73
3 ppm 4701 12 ppm FeCl ₃ 0.2 ppm 2540	1.8	98	23	72
12 ppm FeCl ₃ 3 ppm 4701 0.2 ppm 2540	4.4	95	22	73
3 ppm 4701 12 ppm Alum 0.2 ppm 2540	4.0	95	25	69
4 ppm 4701 15 ppm FeCl ₃ 0.3 ppm 2540	4.5	95	24	70

Note: The raw influent sample consisted of 82 mg/l TSS and 81 mg/l BOD₅.

Table 3.5: Results of Jar Testing by Delta at SESD on December 5, 1989

Chemical Sequence and Concentration	TSS Concentration (mg/l)	TSS Removal Rate (%)	BOD ₅ Concentration (mg/l)	BOD ₅ Removal Rate (%)
5 ppm 4601 15 ppm FeCl ₃ 0.3 ppm 2540	6	96	101	46
5 ppm 4601C 15 ppm FeCl ₃ 0.3 ppm 2540	4	97	92	51
5 ppm 4701 15 ppm FeCl ₃ 0.3 ppm 2540	3	98	86	54
5 ppm 4701C 15 ppm FeCl ₃ 0.3 ppm 2540	6.7	95	82	56
5 ppm 4801 15 ppm FeCl ₃ 0.3 ppm 2540	6.7	95	82	56
5 ppm 4801C 15 ppm FeCl ₃ 0.3 ppm 2540	5.3	96	90	52
5 ppm 4901 15 ppm FeCl ₃ 0.3 ppm 2540	16	89	83	56
5 ppm 4901C 15 ppm FeCl ₃ 0.3 ppm 2540	11	92	80	57

Note: The raw influent sample consisted of 143 mg/l TSS and 188 mg/l BOD₅.

The data from these three tests has been combined and displayed graphically to make the interpretation of the data easier. Figures 3.5a and 3.5b compare different cationic polymer performances in terms of TSS and BOD₅ removal rates for two of the jar test studies. There is an inverse relationship between the cationic polymer identification number and the intrinsic viscosity and molecular weight (the charge density is essentially the same for each polymer). Both plot in Figure 3.5 show that there tends to be an optimal cationic polymer associated with intrinsic viscosity for both the TSS and BOD₅ removal efficiency. The trend is not the same for TSS and BOD₅. Optimal TSS removal is seen in the cationic polymers with the low or high intrinsic viscosity. Optimal BOD₅ removal is seen in cationic polymers with low to mid-range intrinsic viscosity. This suggested that the 4601 cationic should be used in the full scale tests.

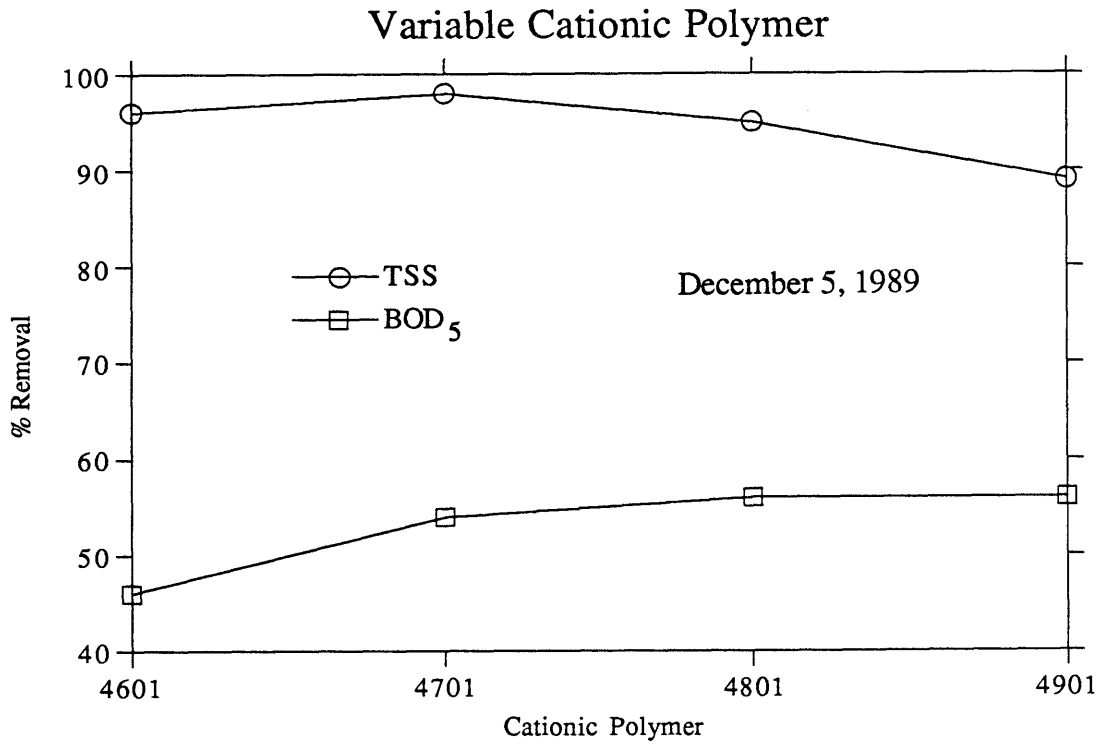
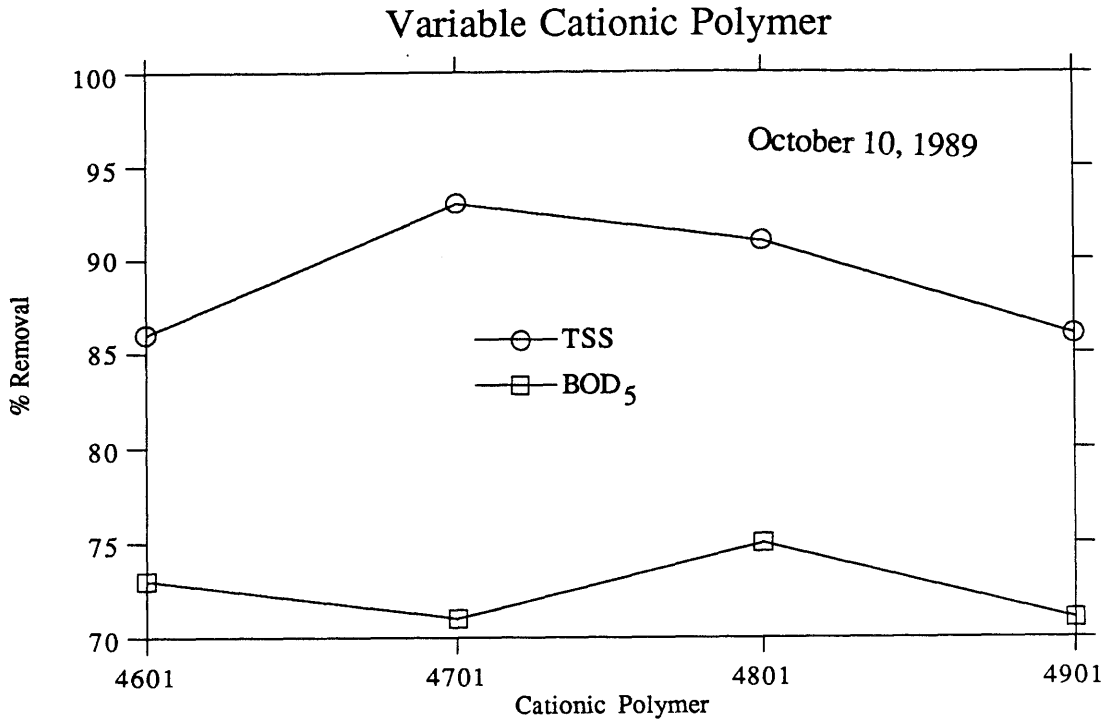

Figure 3.5: TSS and BOD₅ Removal Rates for Various Cationic Polymers

The TSS influent concentration for Figure 3.5a is 88 mg/l and 143 mg/l for Figure 3.5b. These figures indicate that TSS removal rates are higher when the influent concentration is higher. The BOD₅ influent concentration for Figure 3.5a is 150 mg/l and 188 mg/l for Figure 3.5b. These figures indicate that BOD₅ removal rates are higher when the influent concentration is lower. This supports the conclusion drawn in the performance analysis (Morrissey and Harleman, February 1990): SESD's influent BOD₅ concentrations are highly variable in terms of the partitioning of the organic matter.

Figure 3.6 compares the change in anionic polymer concentration to the percent removal of TSS and BOD₅. As shown, TSS removals decreased when the 2540 concentration was increased, but the BOD₅ removals remained high. This suggested that the initial concentration of anionic polymer should be 0.4 mg/l for any ensuing tests.

As seen from the data, TSS and BOD₅ removal rates are fairly insensitive to the order in which the FeCl₃ and cationic polymer is added. However, when the FeCl₃ was added first, BOD₅ removal rates were slightly higher. Jar tests are not very helpful in optimization of chemical usage, especially in evaluating the substitution of cationic polymer for FeCl₃.

It is important to realize that the primary objective of these tests was to determine whether chemical addition could improve overall treatment efficiencies at SESD. The tests indicated that it was possible to improve efficiencies. Another objective of the tests was to determine a chemical addition sequence and a range of chemical concentrations. Based on these jar tests and past experience in San Diego, California, Delta determined that a reasonable order and concentration of chemicals to use at SESD was as follows:

- 20 ppm ferric chloride (FeCl₃)
- 5 ppm cationic polymer (4701 or 4601)
- 0.4 ppm anionic polymer (2540 VHL)

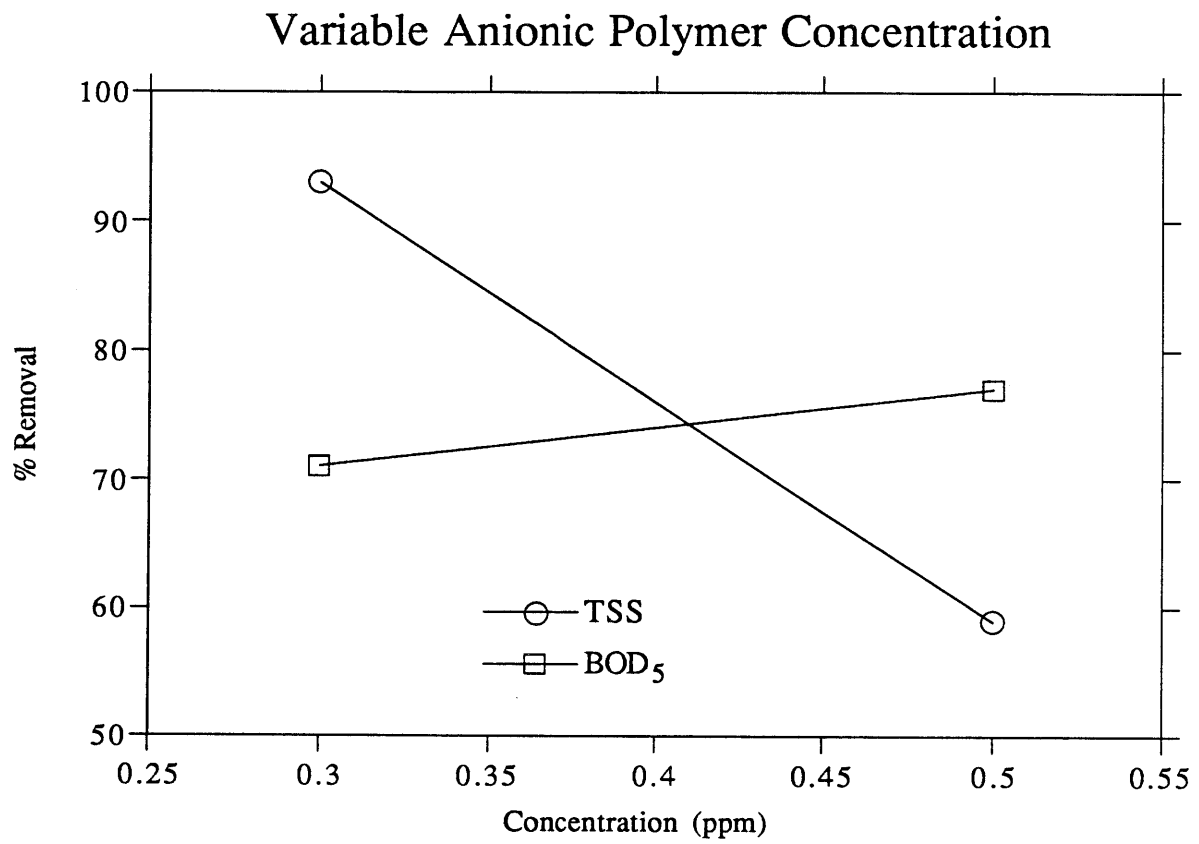

Figure 3.6: TSS and BOD₅ Removal Rates for Various Anionic Polymer Concentrations

Below is the procedure Delta followed during all three of the jar test studies. This jar test procedure was based on the procedure used at the Point Loma treatment facility in San Diego, California.

1. Fill 1000 ml beaker with 800 ml of raw influent.
2. Mix at 100 RPM.
3. Inject FeCl_3 and mix at 100 RPM for 1 minute.
4. Inject cationic polymer and mix at 100 RPM for 1 minute.
5. Reduce mixing to 40 RPM and allow floc to stir for 2 minutes.
6. Increase mixing to 100 RPM and quickly inject anionic polymer. Allow to mix at 100 RPM for 30 seconds.
7. Reduce mixing to 40 RPM and mix for 2 minutes.
8. Reduce mixing to 30 RPM and mix for 1 minute.
9. Reduce mixing to 20 RPM and mix for 1 minute.
10. Turn mixer off and allow mixture to settle for approximately 5 minutes. Observe blanket density and settling rate.
11. Using a 50 - 100 ml syringe, draw samples from 200 ml below the surface. Approximately 150 ml will be needed for TSS and BOD analysis.

Note: The order in which FeCl_3 and the cationic polymers were added was varied to determine the optimal removal rates.

3.2.2 Jar Testing by Tighe & Bond, Inc.

Tighe & Bond conducted two jar test studies at SESD. The first test was conducted between January 16-23, 1990 in order to comply with a court imposed consent decree. In this first test, Tighe & Bond conducted four rounds of tests (trial, preliminary, final, and confirmation) to determine the best mix of chemicals for removing TSS from SESD's influent. Each round was run using metal salts (alum, lime, and ferric chloride) and polymers from three different polymer manufacturers (Delta, Nalco, and Allied). Tables 3.6 and 3.7 contain the results Tighe & Bond obtained during the confirmation round of this study.

Table 3.6: Jar Test Results at SESD From January 16-23, 1990
(Tighe & Bond, February 1990)

<u>Test #</u>	<u>Dose (mg/L)</u>	<u>Color</u>	<u>pH</u>	<u>TSS (mg/L)</u>	<u>% TSS Removal</u>	<u>BOD₅ (mg/L)</u>	<u>% BOD₅ Removal</u>	<u>Fecal Coliform (#/100 mL)</u>	<u>Fats Oil & Grease⁽¹⁾ (mg/L)</u>
56	Lime 60	>30	9.24	46	69.7	74	43.1	2,900,000	<5
	50	>30	9.28	46	69.7	74	41.5	7,500,000	9.0
	0	>30	7.62	72	52.6	92	29.2	5,300,000	8.0
		Influent		152		130		4,600,000	19
57	Alum 55	>30	7.08	42	70.0	66	45.0	1,900,000	<5
	50	>30	7.17	48	65.7	64	46.7	2,600,000	<5
	0	>30	7.72	62	55.7	100	16.7	2,400,000	11
		Influent		140		120		3,600,000	28
58	Ferric 50	25	5.52	14	88.7	71	60.6	10,000	<5
	Chloride 40	15	5.92	9	92.7	74	58.7	20,000	<5
	30	15	6.25	9	92.7	77	57.2	11,000	<5
	0	>30	7.48	84	32.3	140	22.2	2,800,000	<5
		Influent		124		180		2,900,000	15

Notes:

(1) Measured levels of fats, oil and grease (FOG) may be lower than actual because the jar test procedure is not compatible with standard FOG sampling and analysis protocol.

Table 3.7: Jar Test Results at SESD From January 16-23, 1990 for Different Manufacturers (Tighe & Bond, February 1990)

Test #	Inorganic Dose (mg/L)	Cationic Dose (mg/L)	Anionic Dose (mg/L)	Color	pH	TSS (mg/L)	% TSS Removal	BOD ₅ (mg/L)	% BOD ₅ Removal	Fecal Coliform (#/100 mL)	Fats (1) Oil & Grease (mg/L)
59	---	40	1.0	>30	7.51	32	74.2	100	52.4	2,700,000	6
Nalco	---	30	1.0	>30	7.51	38	69.4	120	42.9	7,300,000	12
Cat. N-8768		0	0	>30	7.57	98	21.0	160	23.8	3,300,000	17
An. N-8478					Influent	124		210		4,000,000	46
60	Ferric Chloride										
Delta	30	10	0.4	15	6.29	12	93.8	63	66.8	90,000	<5
Cat. 4601	20	10	0.4	15	6.51	6	96.9	69	63.7	100,000	<5
An. 2540	0	0	0		7.66	108	43.8	140	26.3	2,600,000	22
					Influent	192		190		2,900,000	34
61	Alum										
Delta	50	10	0.4	15	7.14	9	95.3	76	55.3	260,000	6.0
Cat. 4601	40	10	0.4	20	7.19	19	90.1	75	55.9	230,000	6.0
An. 2540	30	10	0.4	20	7.28	15	92.2	84	50.6	300,000	<5
	0	10	0		7.56	82	57.3	130	23.5	2,500,000	21
					Influent	192		170		4,600,000	36
62	Ferric 30	0	1.0	>30	6.43	7	96.7	83	58.5	80,000	<5
Allied	Lime 60	3	1.0	>30	9.09	52	76.5	130	35.0	980,000	8.0
Cat. Per-	0	0	0	>30	7.67	134	36.8	180	10.0	5,900,000	30
col 778					Influent	212		200		2,100,000	42
An. LT 26											
63	---	20	0	>30	7.56	17	91.3	100	47.4	1,300,000	8.5
Allied	---	15	0	>30	7.55	29	85.2	100	47.4	1,600,000	11
		0	0	>30	7.56	80	59.2	160	15.8	2,600,000	23
					Influent	196		190		3,800,000	28

Notes:

(1) Measured levels of fats, oil and grease (FOG) may be lower than actual because the jar test procedure is not compatible with standard FOG sampling and analysis protocol.

From the data presented in Tables 3.6 and 3.7, it is obvious that whenever FeCl₃ was added (alone or in combination with polymers) to the wastewater, effluent fecal coliform counts were very low. Fecal coliform is approximately 0.2 - 0.7 microns in size. There are a few possible explanations for this:

- FeCl₃ is very effective in removing smaller particles.
- The fecal coliform is associated with particles that the FeCl₃ removed.
- The chlorine byproduct produced by FeCl₃ is destroying the fecal coliform.

More detailed research on this is warranted.

Comparing FeCl₃ as the only chemical added versus adding FeCl₃ plus polymers indicates that FeCl₃ is more effective by itself in removing colloid size particles (Tables 3.6 and 3.7). One possible explanation for this is that when FeCl₃ was added without any other polymers, it was mixed for two minutes at high speed and then one minute at low speed, hence promoting coagulation. When FeCl₃ was added along with a polymer, the FeCl₃ had only 30 seconds of contact with the wastewater before the cationic polymer was introduced. Therefore, in order to remove more of the colloid size particles (which would bring both TSS and BOD₅ removal rates up), FeCl₃ should be in contact with the wastewater for a longer period of time than 30 seconds. FeCl₃ consistently removed more fats, oils, and greases than alum or lime.

Graphical representation of the data provided by Tighe & Bond based on the best TSS results obtained for each manufacturer during the confirmation testing is shown in Figure 3.7. This bar graph also shows the results of the BOD₅ analysis performed on the same samples. Delta and Allied were able to out perform Nalco in terms of TSS removal, and Delta out performed Allied and Nalco in terms of BOD₅ removals. Therefore, Delta was selected.

The second jar tests were conducted by Tighe & Bond during the fourth full scale test at SESD (March 25 to April 15, 1990). The purpose of these jar tests was to develop a procedure that personnel at SESD could use to evaluate the chemical concentrations on a daily basis. It is difficult to develop a jar testing procedure that mimics the plant performance because jar tests are batch processes conducted in cylindrical reactors. Chemical addition, mixing, and settling occur all in the same vessel. However, the system

Comparison of 3 Manufacturers (Jan 16 - 23, 1990)

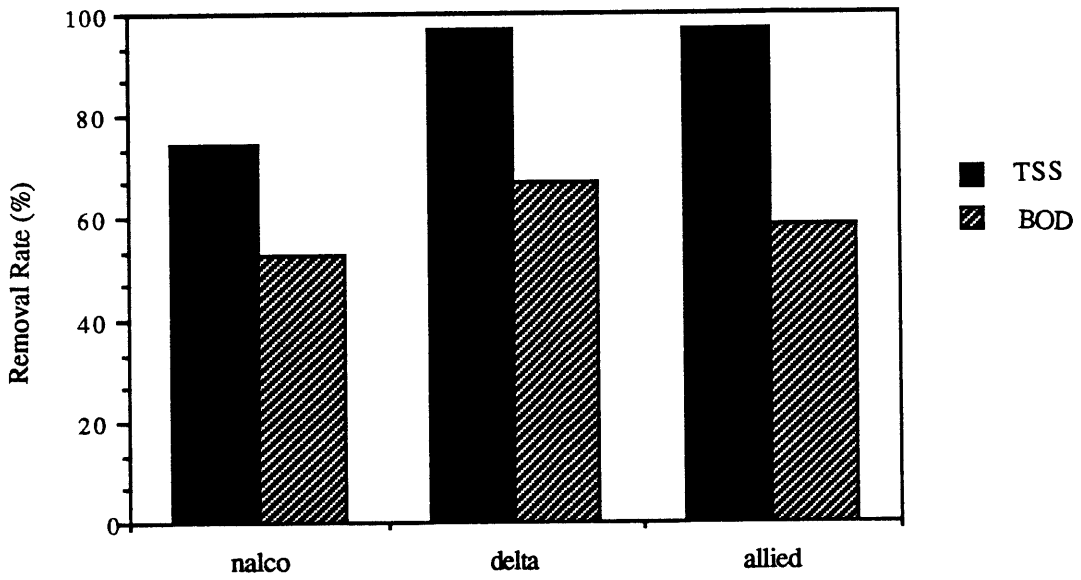

Figure 3.7: TSS and BOD₅ Removal Rates at SEDS for Three Different Manufacturers

that the jar test is trying to model is a continuous flow through system in which chemicals addition, mixing, and settling all take place in different parts of the plant.

3.2.3 Discussion of Jar Testing at SESD

Several points of interest have been gained by gathering this information. These points are as follows:

- Jar testing procedures can affect the overall performance of the jar test.
- The longer FeCl_3 is in contact with the wastewater, the more colloid size particles will be removed.
- Overdosing is possible for all chemicals involved.
- FeCl_3 can remove fecal coliform better than the other metal salts tested.
- Higher viscosity cationic polymers do not necessarily perform better than lower viscosity cationic polymers.
- Much of SESD's organic matter is associated with either colloidal particles or is soluble.
- Large concentrations of FeCl_3 can result in low supernatant pH values.
- Mixing rates strongly affect the overall performance of the jar tests in terms of TSS removal.
- One of the goals in running the jar tests was to mimic the plant performance. This was difficult because jar tests are batch processes conducted in cylindrical reactors. Chemical addition, mixing, and settling occur all in the same vessel. However, the system that the jar test is trying to model is a continuous flow through system in which chemicals addition, mixing, and settling all take place in different parts of the plant.

3.3 Full Scale Tests

Four full scale tests were conducted at SESD: December 18, 1989, January 3, 1990, January 22, 1990, and March 25, 1990. Each of these tests used FeCl_3 supplied by E&F&King Co. Inc. and polymers supplied by Delta. Delta supplied all equipment necessary to add the chemicals to the wastewater and monitored the chemical addition system. SESD's in-house laboratory performed the laboratory analyses for all the tests.

The tests were run for three purposes:

- To determine if chemical addition could improve SESD's treatment efficiency.
- To determine if SESD's current process of sludge handling was acceptable for the sludge produced from the chemical treatment process.
- To comply with a court consent decree.

During the first and second full scale tests, the inflow was separated and only the flow from the Beverly, Danvers, and Marblehead communities was treated with chemicals. During the third and fourth full scale tests, the flow was combined and only half of the inflow was treated with chemicals, the other half was untreated so as to serve as a control.

Before conducting any tests, flow into SESD's plant was sampled and analyzed on the Beverly, Danvers, and Marblehead influent for TSS and BOD₅. The sampling started at 12:00 noon on December 12, 1989 and ran through 6:00 am on December 15, 1989. The sampling device used for this and all of the full scale tests was an ISCO sampler. The ISCO sampler is a discrete sampler; however, during the fourth test, these samplers were modified to take flow composite samples. The ISCO collects approximately 500 ml every hour for 24 hours. These samples were then combined into four composite samples of six hours each. The data collected from December 12-15 is presented below in Table 3.8. There was a three-hour time lag between influent and effluent readings to account for retention times within the treatment plant. The purpose of collecting and analyzing this data was to obtain baseline data in which to compare all subsequent chemical testing.

Table 3.8: Analysis of the Beverly, Danvers, and Marblehead Flow at SESD

Day	Time	TSS in (mg/l)	TSS eff (mg/l)	Removal (%)	BOD in (mg/l)	BOD eff (mg/l)	Removal (%)
12	12n-6pm	135	51	62	240	174	28
12	6 - 12pm	107	56	48	258	177	31
13	12m-6am	94	49	48	204	162	21
13	6 - 12am	81	67	17	228	177	22
13	12n-6pm	199	59	70	132	126	5
13	6 - 12pm	135	73	46	132	141	-7
14	12m-6am	165	63	62	192	150	22
14	6 - 12am	107	64	40	186	150	19
14	12n-6pm	134	66	51	186	153	18
14	6 - 12pm	122	68	44	252	153	39
15	12m-6am	77	46	41	210	141	33
	Average	123	60	48	202	146	21
	Std Dev	36	9	14	43	36	13

3.3.1 Full Scale Test #1 (December 18-19, 1989)

The first full scale chemically enhanced settling test began at 1:00 pm on December 18, 1989 and ended at 6:00 am on December 19, 1989. The plant was run in split mode with only the Beverly, Danvers, and Marblehead flow being treated with chemicals. A plan view schematic of the SESD treatment facility indicating the locations where the chemicals were added is shown below in Figure 3.8.

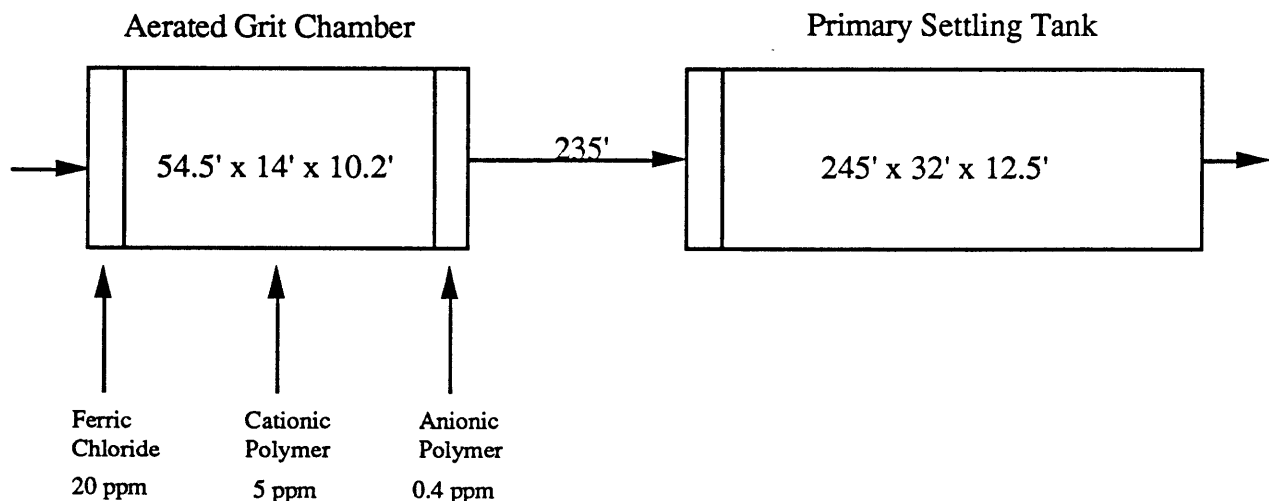

Figure 3.8: A Plan View Schematic of the SESD Treatment Facility (Test #1)

As shown, FeCl₃ was added to the wastewater stream as it entered the aerated grit chamber. Approximately half way down the grit chamber, the cationic polymer (Delta 4601) was added. This allowed the FeCl₃ about three minutes to mix with the wastewater before coming in contact with the cationic polymer. Finally, as the wastewater was flowing over the outlet weir of the grit chamber, the anionic polymer (Delta 2540 VHL) was added. This allowed the FeCl₃ and the cationic polymer about three minutes to mix before coming in contact with the anionic polymer. The chemical concentrations throughout the test were targeted to be as follows:

- 20 ppm FeCl₃
- 5 ppm cationic polymer (4601)
- 0.4 ppm anionic polymer (2540 VHL)

These concentrations were gauged by the flow and manually adjusted every few hours.

This test was conducted under the assumption that the experience gained by Delta Chemicals at Point Loma treatment facility in San Diego, California could be transferred to the SESD treatment facility. As experiments go, SESD's treatment process was different enough from San Diego's to warrant stopping the trial after approximately 25 hours because turbulence and shearing forces caused by the flow were so great that they broke up the flocs. Once the floc is broken apart, it is difficult to reform it.

Table 3.9 shows the data collected by SESD during the first full scale test. The data represents six-hour time composites beginning 12/18/89 at 12:00 noon. There was a three-hour time lag between influent and effluent readings to account for detention time within the treatment facility. Sampling was done with an ISCO sampler.

Table 3.9: Results From Full Scale Test #1 on the Beverly, Danvers, and Marblehead Side

Day	Time	TSS in (mg/l)	TSS eff (mg/l)	Removal (%)	BOD in (mg/l)	BOD eff (mg/l)	Removal (%)
18	12n-6pm	542	37	93	294	123	58
18	6pm-12m	128	53	59	207	142	31
18-19	12m-6am	92	54	41	180	135	25
	Average	254	48	64	227	133	38
	Std Dev	250	10	26	60	10	18

Note: The trial was stopped after the first day due to break-up of flocs caused by too much turbulence within the system.

It was determined that the floc break-up observed in Test #1 was due to excessive turbulence in the system. The primary cause of the turbulence can be traced to five sources. These sources are as follows:

- Aerated grit chamber
- Flow over the weir of the grit chamber
- Flow through the conduits
- The aerated influent channel before the sedimentation tanks
- The timber baffles at the entrance to the sedimentation tanks

Based on these observations and the test results, another test was scheduled for January 3, 1990 and the locations of chemical additions were changed.

3.3.2 Full Scale Test #2 (January 3-4, 1989)

The second full scale chemically enhanced settling test began at 8:00 am on January 3, 1990 and ended at 8:00 am on January 4, 1990. The plant was run in split mode with only the Beverly, Danvers, and Marblehead flow being treated with chemicals. A plan view schematic of the SESD treatment facility indicating the locations where the chemicals were added is shown in Figure 3.9.

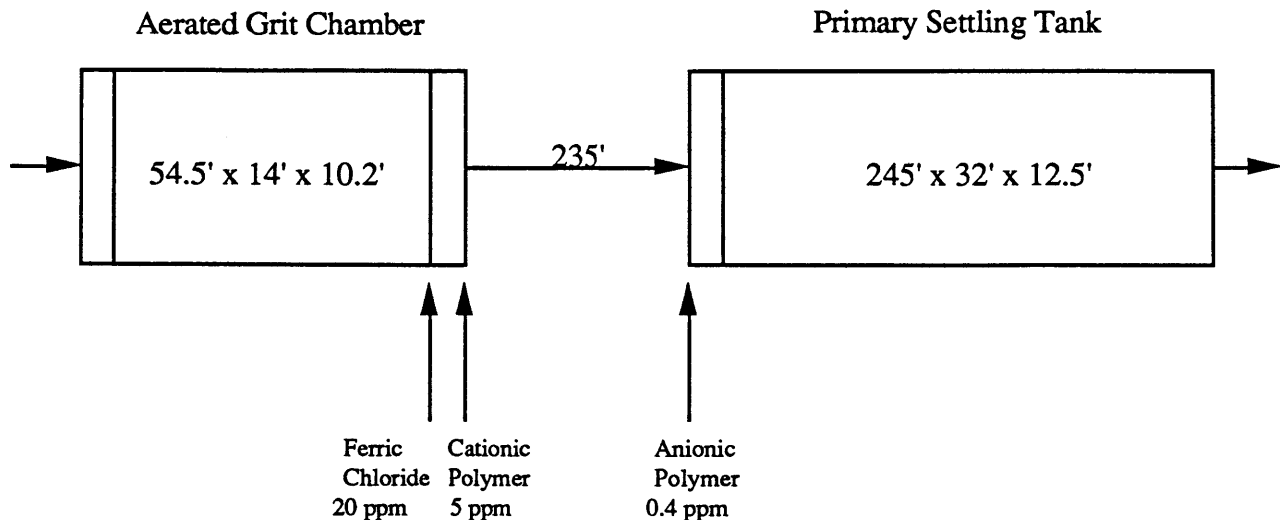

Figure 3.9: A Plan View Schematic of the SESD Treatment Facility (Test #2)

FeCl_3 was added to the wastewater stream as it flowed over the outlet weir of the grit chamber. The cationic polymer was added approximately 15' down the conduit leading to the 235' section of conduit that transports the wastewater from the grit chamber to the aeration influent channel of the sedimentation tanks. This allowed the FeCl_3 about 20 to 30 seconds to mix with the wastewater before coming in contact with the cationic polymer. Finally, the anionic polymer was added approximately six feet from the base of the conduit leading into the aeration influent channel. This allowed the FeCl_3 and the cationic polymer about four minutes to mix before coming in contact with the anionic polymer.

The FeCl_3 , cationic polymer, and anionic polymer mixture was in contact with the wastewater for about two to three minutes before reaching the sedimentation tanks. Once the wastewater reached the sedimentation tanks, solid particles settled out in an average detention time of three hours. The liquid that remained after this settling process was chlorinated and discharged as effluent into the ocean.

The chemical concentrations throughout the test were targeted as follows:

- 20 ppm FeCl_3
- 5 ppm cationic polymer (4601)
- 0.4 ppm anionic polymer (2540)

These concentrations were gauged by the flow and manually adjusted every few hours.

A certain amount of floating floc was observed at the entrance to the sedimentation tanks; therefore, it was decided that the length of the test should be limited. The test was run only long enough to collect enough sludge to determine whether SESD's current method for processing the sludge would also work with the sludge generated by chemical addition. After 24 hours, enough sludge was collected and SESD was able to process the sludge; however, the solids content was lower than normal and more polymer was needed to dewater the sludge.

Table 3.10 shows the data obtained by SESD during the period of chemical addition. The data represents six-hour time composites beginning 1/3/90 at 8:00 am. There was a three-hour time lag between influent and effluent readings to account for detention time within the treatment facility. Sampling was done with an ISCO sampler.

Table 3.10: Results From Full Scale Test #2 on the Beverly, Danvers, and Marblehead Side

Day	Time	TSS in (mg/l)	TSS eff (mg/l)	Removal (%)	BOD in (mg/l)	BOD eff (mg/l)	Removal (%)
3	8am-2pm	144	32	78	149	90	40
3	2pm-8pm	392	35	91	195	98	50
3-4	8pm-2am	418	43	90	241	103	57
4	2am-8am	153	40	74	173	97	44
	Average	277	38	83	190	97	48
	Std Dev	149	5	9	39	5	7

Note: The trial was stopped after the first day because enough sludge was available for testing. At this point, a trial and error procedure was established to determine the cause of the floating floc.

The high TSS removal rates were excellent considering the problems encountered due to floating floc. It is believed that the floating floc was due to the association of fats, oils, and greases with the floc. Also, the tremendous amount of turbulence and air entrainment in the system created air bubbles within the floc. However, even with the floating floc problem, the data indicates that the chemical/polymer addition process was successful. In order to correct this problem, the following attempts to control air entrainment were carried out before the test on January 22, 1990.

- The air vents for the 235' conduits were opened in order to reduce the air entrapment.
- The air in the influent channel before the sedimentation tanks was turned off.

3.3.3 Full Scale Test #3 (January 22-26, 1990)

On January 22, 1990, SESD began a five-day test that involved adding chemicals and polymers to their primary treatment plant to improve treatment efficiency. In this test, the flow from all of the SESD communities was combined (unlike the first and second tests in which the treated flow was from the Beverly, Danvers, and Marblehead communities only). The combined flow was split into parallel streams and chemicals were added to half of the flow. This allowed a direct comparison between treated and untreated effluent.

A schematic of the SESD treatment facility and the locations where the chemicals/polymers were added is shown in Figure 3.10.

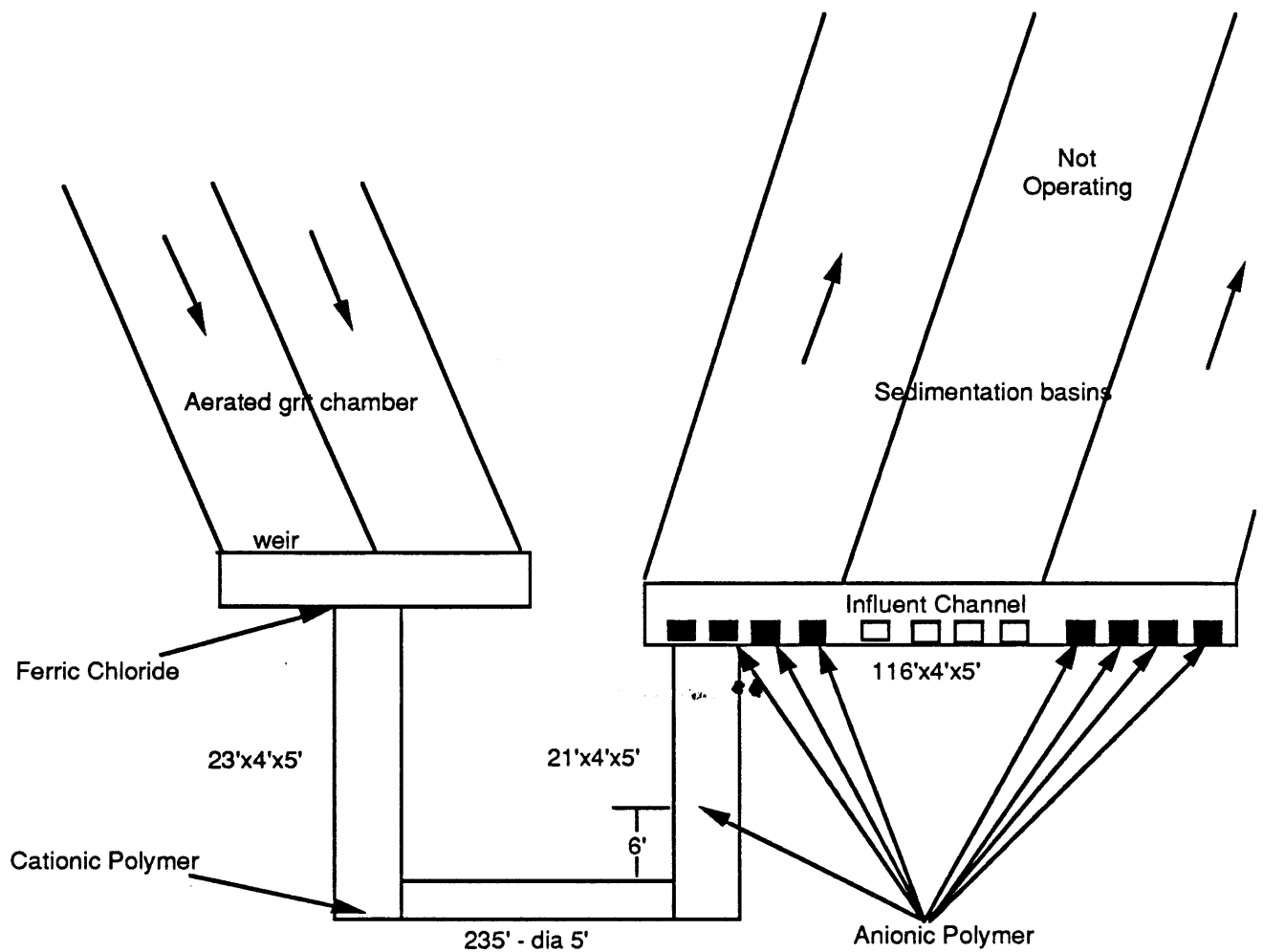

Figure 3.10: Schematic of SESD's Treatment Facility, Treated Side Only (Test #3)

FeCl_3 was added to the wastewater stream just below the surface of the vertical conduit after the grit chamber weir. The cationic polymer was added at the base of the vertical conduit leading to the 235 ft section of conduit that transports the wastewater from the grit chamber to the influent channel. This allowed the FeCl_3 about 15 to 40 seconds to mix with the wastewater before coming in contact with the cationic polymer. Finally, the anionic polymer was added approximately six feet up from the base of the vertical conduit leading into the influent channel of the sedimentation tanks. Near the end of the test, additional anionic polymer was added just before the timber baffles in the sedimentation tanks. This allowed the FeCl_3 and the cationic polymer two to six minutes to mix before coming in contact with the anionic polymer.

Chemical concentration is dependent upon the rate at which the chemicals are fed into the wastewater and the plant flow rate. Delta measured the chemical feed rates based on readings taken at the effluent flow meter. During the test, the flow rate on the treated side of the plant was assumed to be half of the plant's total flow. This assumption was based on measuring the height of the flow over the weirs of the grit chambers.

SESD measured and analyzed TSS and BOD₅ throughout the testing period. Compositing intervals for the samples are from 8:00 am to 2:00 pm, 2:00 pm to 8:00 pm, 8:00 pm to 2:00 am, and 2:00 am to 8:00 am. Turbidity, dissolved oxygen (DO), and temperature readings were taken throughout the test by Delta and MIT. The sludge from both the treated and untreated sides of the plant was collected and processed separately throughout the study by SESD.

A detailed analysis of the data obtained during Test #3 was performed by Morrissey and Harleman (March 1990). Only the conclusions from this study will be given.

3.3.3.1 Conclusions From Full Scale Test #3

SESD had two major objectives for running this test. The first objective was to collect enough sludge to determine whether the method currently being used at SESD to dewater the sludge would also work with sludge generated by the chemical treatment process. This objective was successfully achieved with the solids content of the sludge averaging 4.0% and the dewatered cake averaging 31.4% solids. The solids content of the sludge on the treated side averaged 4.5% and the dewatered cake averaged 33.7% solids. The second objective was to determine whether TSS and BOD₅ removal rates could be improved by chemical addition. This objective was also achieved with TSS removals rates averaging 62% on the treated side and 39% on the untreated side. BOD₅ removal rates for the treated side were above 40% and the average for the year was only 24%. No BOD₅ data was gathered on the untreated side.

The test period coincided with a time of high flow and low influent concentrations. Fluctuations in flows and influent concentrations are the norm at SESD; therefore, the chemical addition process must be able to optimize removal rates over a wide range of conditions. The best approach is to optimize during low concentration periods because as

influent concentrations increase, removal rates also tend to increase. This trend is due to particle-particle interaction and more effective sweeping.

3.3.4 Full Scale Test #4 (March 25 - April 15, 1990)

On March 25, 1990, SESD began a 22-day test that involved adding chemicals and polymers to their primary treatment plant in order to improve treatment efficiency. The results of this test and the analysis of the results was compiled in a report (Morrissey and Harleman, May 1990).

In this test, the flow from all of the SESD communities was combined (unlike the tests on December 18th and January 3rd in which the treated flow was from the Marblehead, Danvers, and Beverly communities only). The combined flow was split into parallel streams and chemicals were added to half of the flow. This allowed a direct comparison between treated and untreated effluent.

Chemicals used during this test were supplied by E & F & King Co. Inc. (ferric chloride) and Delta Chemicals Inc. (polymers). Delta monitored the chemical feed system. SESD's in-house laboratory performed the laboratory analyses for the test. SESD's in-house laboratory also performed the laboratory analysis on all samples taken for their NPDES permit.

The purpose of the 22-day test was comply with the court-ordered consent decree which stated that SESD must perform a full scale investigation of chemical addition for a three week duration. Specifically, the interim partial consent order (December, 1989) states:

"SESD shall conduct an evaluation of the effects on treatment plant removal efficiency from feeding various chemicals into the primary clarifier influent for the purpose of determining whether chemical addition will improve plant performance for removal of biochemical oxygen demand and total suspended solids for the period prior to completion of secondary treatment facilities."

The 22-day test was run under three different chemical addition point scenarios to test the effects of the changes. These scenarios are summarized as follows:

Scenario 1 (March 25 - April 9) The FeCl₃ was added to the wastewater stream just below the surface of the vertical conduit after the grit chamber weir (Figure 3.11). The cationic polymer was added at the base of the vertical conduit leading to the 235' section of conduit that transports the wastewater from the grit chamber to the influent channel. Finally, the anionic polymer was added approximately six feet up from the base of the vertical conduit leading into the influent channel of the sedimentation tanks.

Scenario 2 (April 9 - April 12) The only difference between the first and second scenario is that the FeCl₃ was added to the wastewater at the upstream end of the grit chambers (Figure 3.12). Two grit chambers in parallel were operational during this period. This allowed the FeCl₃ additional time to mix before coming in contact with the cationic polymer.

Scenario 3 (April 12 - April 16) The only difference between the first and third scenario is that additional anionic polymer was added just before the timber baffles in the sedimentation tanks (Figure 3.13). One grit chamber was operational during this period. See concentration of chemicals added in Table 3.11.

Table 3.11: Chemical Concentration (mg/l) for Test #4

Time Interval	Ferric Chloride	Cationic Polymer	Anionic Polymer
3/25 - 4/2	20	10	0.4
4/2 - 4/12	20	5	0.5
4/12 - 4/15	20	10	0.5

The pumps that fed the chemicals were electrically connected to the effluent flow meter resulting in a constant concentration of chemicals being added to the wastewater. During the test, the flow rate on the treated side of the plant was assumed to be 53% of the plant's total flow. This assumption was based on measuring the relative height of the flow over the weirs of the grit chambers.

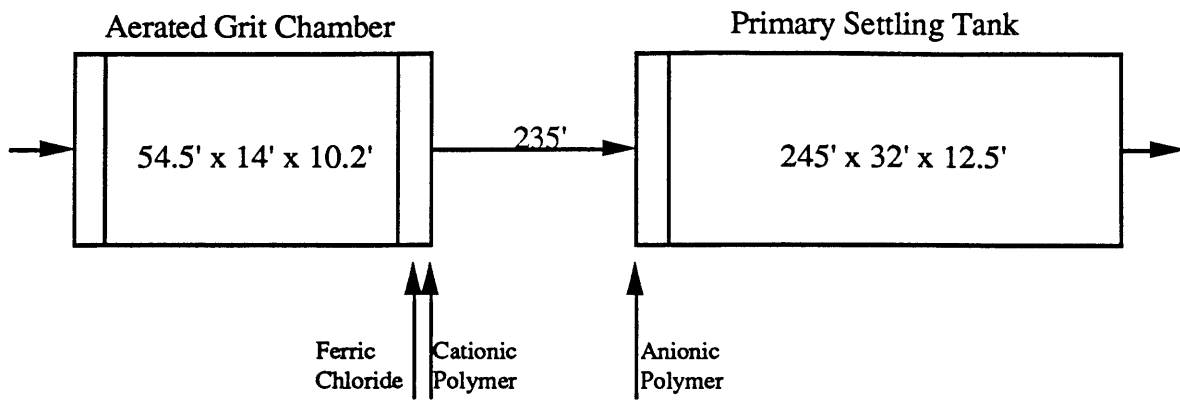

Figure 3.11: Schematic of SESD's treatment plant showing the location of chemical injection for Scenario 1 (March 25 - April 9).

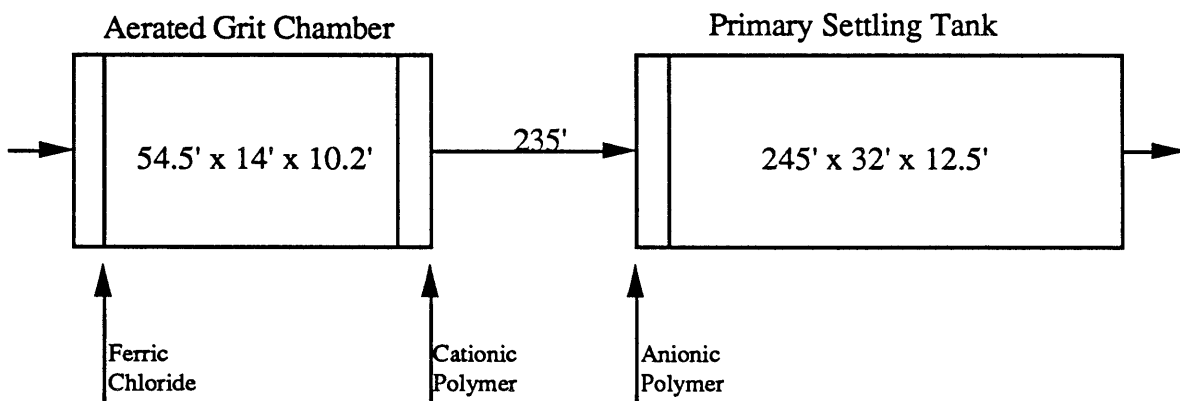

Figure 3.12: Schematic of SESD's treatment plant showing the location of chemical injection for Scenario 2 (April 9 - April 12).

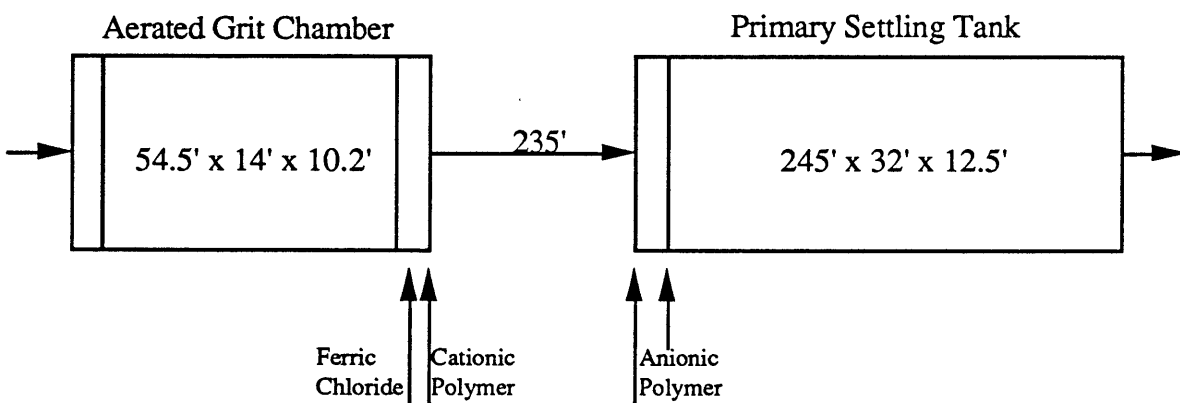

Figure 3.13: Schematic of SESD's treatment plant showing the location of chemical injection for Scenario 3 (April 12 - April 16).

SESD measured TSS and BOD₅ (Figure 3.4) throughout the testing period using an ISCO sampler, which was modified to take flow composite samples. The ISCO collects approximately 500 ml every hour for 24 hours. These samples are then combined into four composite samples of six hours each. Compositing intervals are from 8:00 am to 2:00 pm, 2:00 pm to 8:00 pm, 8:00 pm to 2:00 am, and 2:00 am to 8:00 am. To reduce the number of samples analyzed, the composite samples for BOD₅ were again mixed into these intervals: 8:00 am to 8:00 pm and 8:00 pm to 8:00 am. Daily NPDES permit samples for TSS and BOD₅ were taken based on 24 hour flow composites from a Chicago sampler of the combined influent and effluent flow. Sampling intervals were from 6:00 am to 6:00 am.

The pH of the influent (6.9) and effluent (6.75 on the treated side and 6.7 on the untreated side) was measured by SESD continuously throughout the test and minimal variation was found. Beginning April 3rd, Tighe & Bond installed a streaming current detector (SCD). As flow passes through the SCD, the counterions in the diffuse layer surrounding the colloids migrate with the flow creating a current that can be measured (Dentel and Kingery, 1989). This current is proportional to the electrical potential or zeta potential. The streaming current reading indicates the electrical charge of the colloids; hence, the extent to which destabilization occurs. Variations in the SCD measurements were significant during the last week of the test.

The sludge from both the treated and untreated sides of the plant was collected and processed separately throughout the study by SESD.

Throughout the test, operational adjustments were made at SESD. The most significant was associated with taking the sedimentation tank off-line. From March 25 through April 3, two sedimentation tanks were operational on both sides of the plant. There was one six hour period on March 28 when one of the tanks was not operational on the treated side of the plant. From April 3 through April 16, three sedimentation tanks were operational on both sides of the plant. During the period of April 5 - 6 and April 9 - 12, the untreated side had only two tanks operational. These changes were constructive because they allowed the effects of higher overflow rates on plant performance to be examined. Also, throughout the test, there were operational difficulties with the scum collecting equipment on the treated side of the plant. This may have resulted in carry-over of some solids.

A detailed analysis of the raw data obtained during Test #4 was performed by Morrissey and Harleman (May, 1990). Only the conclusions from this study will be given.

3.3.4.1 Conclusions From Full Scale Test #4

SESD had two major objectives for running this test. The first objective was to comply with the interim partial consent decree. Two separate reports were submitted by the compliance deadline – one by Tighe & Bond and one by MIT. The second objective was to determine whether TSS and BOD₅ removal rates could be improved by chemical addition. This objective was also achieved with TSS removals rates for the entire plant of 54% for the treated side and 34% for the untreated side. BOD₅ removal rates were 51% for the treated side and 17% for the untreated side.

The test period consisted of three distinct flow regimes: a period of "normal" flow, a period of unusually high flow, and a period of flow higher than normal resulting from inflow and infiltration.

There are a number of important conclusions that can be drawn from the raw data and the analysis of this raw data. These conclusions are presented below:

- Influent concentrations were low during the period of high flow; however, the chemically-treated side of the plant was able to respond without a deterioration in performance.
- During the period of high flow (days 9 - 13), flow varied from <25 mgd to >85 mgd within a period of 12 hours. The chemical treatment process was able to respond with no deterioration in performance. The performance on the untreated side was much more variable.
- During the last part the test (days 13 - 22), there was a distinct variation in the characteristics of the flow entering the treatment plant as seen by the streaming current detector readings and the response of the system.
- During the last part of the test (days 13 - 22), there appeared to have been a problem with the TSS effluent concentration sampling. This is indicated when the six and 12 hour composites averaged over 24 hours for TSS and BOD₅ were compared with influent and effluent 24 hour composites sampled and analyzed

by SESD. A major discrepancy occurred during this period for TSS effluent concentration.

- TSS and BOD₅ removal rates for the treated side of the plant are not as dependent on influent concentration as the untreated side of the plant.
- The chemical treatment process is not strongly dependent on overflow rates; therefore, smaller surface areas are needed to obtain similar removal rates for TSS and BOD₅.
- BOD₅ effluent concentrations and removal rates were extremely constant throughout the testing period on the treated side.

3.3.4.2 Discussion of Full Scale Test #4

Analyzing the data as three distinct periods was very constructive. This approach demonstrated that the chemical treatment process is effective in improving the treatment efficiency at an existing facility. During the first 13 days of the test, the treated side removal rates for BOD₅ were 195% better than the untreated side. For the last nine days, the corresponding percentage increase in BOD₅ removal was 186%. During the first 13 days of the test, the treated side removal rates for TSS were 72% better than the untreated side; however, for the last nine days, TSS removal rates were only 26% better. There is no logical reason why the TSS removal efficiency for the last nine days should have fallen while the BOD₅ removal efficiency remained essentially constant. Figure 3.14 shows that there is a significant disagreement in the TSS six hour composite averaged over 24 hours and the 24 hour composite data for the last nine days. The most reasonable explanation is that the TSS data for this period is suspect.

If it is assumed that the six hour TSS composite data are correct, two possible explanations have been advanced for the high variability in TSS removal rates. The first is that there was a build-up of neutrally buoyant floc in the settling tank that accumulated over time until the entire tank was filled (steady state). If this was the case, then steady state is reached after approximately 15 days. This explanation seems unlikely. There was a period of very high flow (>85 mgd) just prior to this. If a build up of neutrally buoyant floc was present in the settling tanks, it is reasonable to expect a wash out of the floc during the preceding period of high flow. The data indicates that this did not happen. To the author's knowledge, there has been no occurrence of this type of neutral buoyancy floc accumulation at any other chemically-enhanced treatment facility.

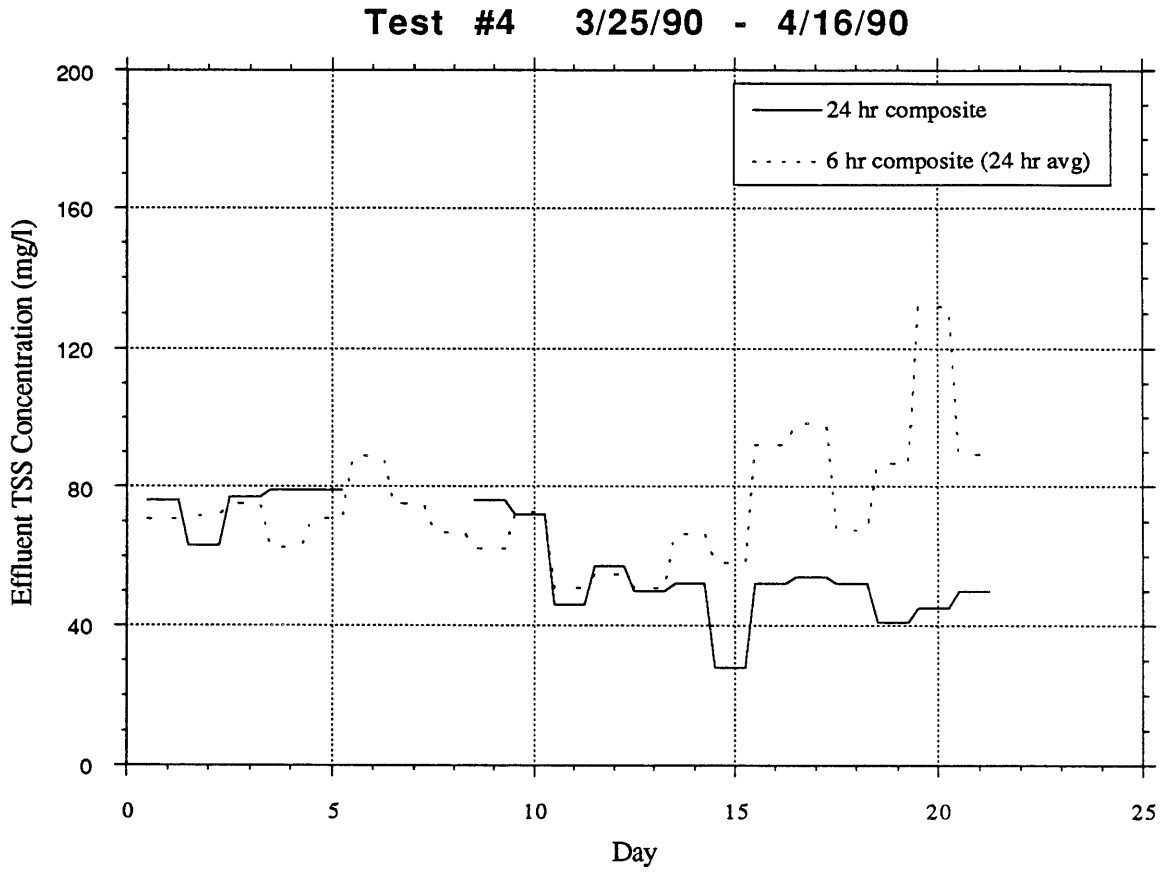

Figure 3.14: Comparison of TSS Effluent Samples Analyzed by Different Samplers at SESD

The second explanation for the high variability in removal rates is that there was a significant change in the influent characteristics during the last nine days of the test. This change is shown in the SCD measurements in Figure 3.15. Anomalous changes in charge found in the SCD readings correspond to the periods of largest TSS effluent concentrations.

It is interesting to speculate on why the increase in BOD₅ removal with chemical treatment was much higher than the increase in removal for TSS. The explanation is in the nature of the "standard methods" test on which TSS removals are based. The TSS test is based on solids captured on a 0.7 µm filter, thus solids in the colloidal size range less than 0.7 µm that are removed by chemical precipitation and coagulation are not counted as TSS removed. The BOD test, on the other hand, measures BOD removal over the entire particle range. Table 3.12 shows a significant reduction in both colloidal and soluble particle size removal by chemical treatment.

Table 3.12: Particle Size Distribution for Influent and Effluent Data at SESD.

Date	Time	Measurement	Particle Size (µm)			
			Settleable (>100)	Supracolloidal (1.2-100)	Colloidal (0.1-1.2)	Soluble (<0.1)
4/2	2pm-8pm	Treated Inf (Total)	50	120	-6	876
		(Volatile)	60	47	1	164
		(Fixed)	-10	63	-7	712
4/7	2pm-8pm	Treated Inf (Total)	68	38	5	995
		(Volatile)	74	-	24	310
		(Fixed)	-	50	-	685
4/7	2pm-8pm	Treated Eff (Total)	-	-	248	720
		(Volatile)	2	-	-	265
		(Fixed)	-	26	251	455
4/11	2pm-8pm	Treated Inf (Total)	42	10	108	1532
		(Volatile)	6	54	-	280
		(Fixed)	36	-	92	1252
4/11	2pm-8pm	Treated Eff (Total)	16	-	8	1392
		(Volatile)	6	-	-	272
		(Fixed)	10	-	48	1120

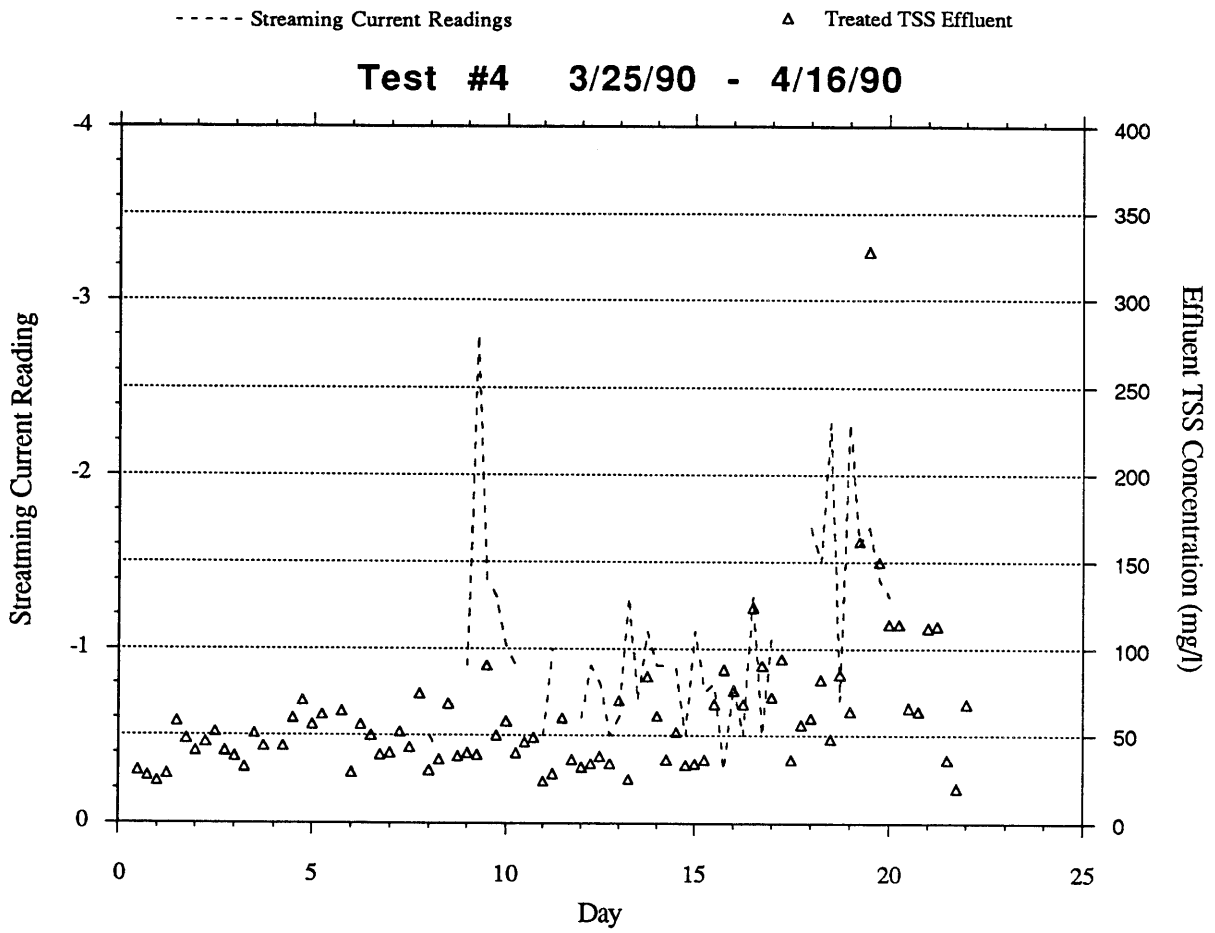

Figure 3.15: Streaming Current Reading for Each Day Overlaid on Treated TSS Concentration for Each Day

3.3.5 Discussion of Full Scale Testing at SESD

In this section, variables that were found to influence the coagulation and flocculation processes, and hence performance, will be discussed. These variables include hydrodynamics, location of chemical addition, mixing rates, contact time of the chemicals, and electrical charge of the wastewater. Finally, recommendations for the continuation of chemically-enhanced wastewater treatment on a full time basis at SESD are given.

3.3.5.1 Hydrodynamics

The two main hydrodynamic problems encountered during the testing at SESD were air entrainment and break-up of the floc. Both problems resulted from the tremendous amount of turbulence. The five main sources of turbulence were:

- the aerated grit chamber
- flow over the weir of the aerated grit chamber
- flow through the conduits
- the aerated influent channels
- the timber baffles in the sedimentation tanks

During the second and third full scale tests, dissolved oxygen (DO) was measured. Just before the flow traveled over the grit chamber weir, the DO values were 2 mg/l. As the flow entered the influent channel leading to the sedimentation tanks, the DO values were approximately 5 mg/l. This large increase in DO is primarily due to the entrainment of air bubbles. These air bubbles could also be seen escaping to the atmosphere as the flow entered the sedimentation tanks. When chemicals were added, floc formed. Air bubbles became entrapped beneath some of the floc causing it to float. To alleviate some of the problem, an air vent in the 235 ft horizontal conduit was left open during the third and fourth tests.

During the first full scale chemical treatment test at SESD, all chemicals were added in the grit chamber to allow the maximum contact time for all the chemicals. However, due to the large amount of turbulence in the system and the early formation of floc, the floc broke apart. The shearing forces in the conduit were considered the primary cause and in

all subsequent tests, the anionic polymer was added after the flow passed the 235 ft horizontal conduit. It is important to form large floc after areas of high turbulence.

3.3.5.2 Chemical Mixing, Contact Time, and Location

The location where the chemicals are added to the wastewater is important in the chemical treatment process because location determines the mixing rate and the contact time of the chemicals. Mixing rate is important because the more rapid the initial mixing, the better the chemicals are dispersed leading to more efficient coagulation and flocculation. Contact time is important because the longer the chemicals are in contact with the wastewater, the more particle interactions occur. Throughout the four full scale tests at SESD, chemicals were added in four different locations (Figures 3.8, 3.11, 3.12, and 3.13).

During the first test, all of the chemicals were added in the grit chamber (Figure 3.8). It was assumed that the increase in contact time would produce more floc and stronger floc. However, large floc formed quickly and the shearing forces within the conduits were so strong that the floc broke apart.

In subsequent tests, all chemicals were added after the grit chamber (Figures 3.11 and 3.13) and the best results were obtained. It is believed that these results were due to the near-complete mixing at the injection points of the FeCl_3 and the cationic polymer. The concentration of anionic polymer injected at each of the two locations (Figure 3.13) was varied. Slight improvements were noted when a portion of the anionic polymer concentration was injected before the timber baffles in the sedimentation tanks. It is believed that this improvement was due to the incomplete mixing of the anionic polymer when injected within the conduit.

It was anticipated that adding the FeCl_3 at the head of the grit chamber (increasing contact time) would improve the performance on the treated side of the plant (Figure 3.13). It was unfortunate that during this time, a dramatic change in the overall characteristics of the wastewater took place. Therefore, the possible benefits of increased contact time for the FeCl_3 were undetermined. An increase in contact time has proven beneficial in California and Norway (Harleman and Morrissey, 1990).

3.3.5.3 Electrical Charge

Coagulation involves destabilization of colloidal particles by sweep coagulation, charge neutralization, and interparticle bridging (see Chapter 1). The primary mechanism for destabilization using FeCl_3 at SESD was charge neutralization. During the last portion of the fourth full scale test, Tighe & Bond installed a streaming current detector (SCD) in the grit chamber of the treated side of the plant. For a portion of this period, there were anomalous spikes in the readings indicating that there was a change in the charge of the incoming wastewater. High TSS effluent concentration corresponded with the anomalous spikes. This indicates that charge along with flow is important when determining the proper chemical concentration to be added. Figure 3.15 shows variations in charge corresponding to variations in TSS effluent concentration indicating an under-dosing of FeCl_3 during these times.

3.3.6 Recommendations For Future Chemically-Enhanced Testing at SESD

SESD should continue using chemical addition to improve settling at their existing primary treatment facility. This process has dramatically improved their removal efficiency. However, it is recognized that additional testing is necessary to optimize this process and to provide information on BOD removal upon which to base the design of additional treatment facilities.

In order for SESD to continue with the chemical treatment process on an ongoing basis, a few modifications must be made to the existing plant. These modifications would improve operations and the performance of the plant. At a minimum, SESD should do the following:

- The scum collecting equipment must be upgraded to accommodate the increase in scum resulting from the increased capture of fats, oils, and greases during chemical addition.
- The effluent flow meter should be upgraded to handle a minimum flow of 100 mgd. Currently, it is limited to 55 mgd.
- Chemicals should be added as shown in Figure 3-12; however, a more complete mixing of the chemicals is required.

- Chemical mixing and feed equipment must be installed on a permanent basis.
- Chemical concentrations should be paced to the effluent flow on a permanent basis.
- A streaming current detector should be installed and monitored so that chemical concentrations could be also paced according to charge.
- It has been shown that seawater aids in coagulation (Odegaard, 1989); therefore, it is recommended that the FeCl_3 be thoroughly mixed with seawater equal to 3% of the plant flow rate before introducing it into the wastestream. Seawater added with FeCl_3 helps the initial mixing and dilution of the FeCl_3 , which is critical in the coagulation process.

To further improve advanced primary treatment efficiency at SESD, the addition of flocculation basins should also be considered. Flocculation basins have proven to be effective in promoting particle-particle interaction in Scandinavia (Odegaard, 1988 and Karlsson, 1988). At SESD, flocculation basins should be installed for a long term chemical addition process. One such option would be to construct flocculation basins next to the operations building (downstream of the aerated grit chambers and upstream of the sedimentation tanks). This would eliminate the existing 235 ft conduit that has been a continuing problem due to excessive turbulence and air entrainment.

Chapter 4

DISCUSSION

4.1 Introduction

"Since clarification is the most economical way to remove suspended and colloidal pollutants, every effort should be made to improve the primary clarification process" (EPA, 1974). This quote was initially directed towards the removal of solids; however, even more appropriately, it refers to the removal of BOD.

There are many ways to upgrade an existing primary treatment facility to meet secondary standards set by EPA. An appropriate way is to improve the performance of the primary clarifier in terms of both TSS and BOD removals through chemical addition. Two ways that this can be accomplished are discussed below:

- Add chemicals to achieve advanced primary efficiencies (80% TSS and 60% BOD removals) and construct a small scale biological plant to follow.
- Construct flocculation basins before the primary clarifiers to achieve chemical secondary efficiencies (90% TSS and 85% BOD removals). This is the obvious choice when a new facility is being built.

In this chapter, upgrading an existing primary treatment plant and developing a new facility will be discussed in terms of design parameters such as overflow rate and biochemical oxidation rate, sludge characteristics, and costs. A comparison between different treatment processes will be presented where appropriate.

4.2 Overflow Rate

The mechanism for removing pollutants in a conventional primary treatment plant is settling by gravity in sedimentation tanks. Within these tanks, two additional mechanisms take place – natural coagulation/flocculation and differential settling – both of which aid settling. Coagulation/flocculation occurs naturally in wastewater due to contact caused by fluid motion and destabilization of colloidal particles (see Chapter 1). Differential settling

occurs when a large particle overtakes a smaller particle causing the smaller particle to be trapped beneath the large particle; hence, accelerating its descent. The addition of chemicals enhances the coagulation and flocculation process resulting in the formation of large and rapidly settling particles.

Traditionally, sedimentation tanks have been designed based on overflow rate. The overflow rate is defined as the flow over the surface area of the sedimentation tank (gpd/ft^2). A parameter related to overflow rate is the retention time, which is defined as the depth of the tanks divided by the overflow rate. This parameter is used in determining the depth of the settling tanks.

The Water Pollution Control Federation (WPCF) has attempted to standardize the recommended overflow rate based on required TSS and BOD_5 removal rates (Figure 4.1). These figures do not reflect chemically-enhanced settling. As seen in Figure 4.1, to obtain removal rates of 60% for TSS and 35% for BOD_5 , overflow rates must be less than 800 gpd/ft^2 . When chemicals are added to the primary settling tanks, the overflow rate can be increased significantly without loss of performance. In Figure 4.2, data from a number of treatment facilities has been collected and graphed to show the effects of chemical addition on the overflow rate. When chemicals are added, overflow rates of greater than 2000 gpd/ft^2 have been observed while maintaining TSS removal rates of greater than 80% and BOD_5 removal rates of greater than 55%.

At the Point Loma plant in San Diego, a study was conducted on the full plant to determine the maximum overflow rate that could be maintained without seriously deteriorating the effluent quality. Data from this study indicated that overflow rates as high as 3000 gpd/ft^2 could be maintained while decreasing TSS removal rate by only two percentage points (Konopka, 1990).

A study conducted at the Sarnia plant in Ontario, Canada (Hienke, et al., 1983) showed that the addition of FeCl_3 and polymers to the primary settling tanks dramatically improved the performance of the tanks (Figure 4.3). The TSS data obtained when FeCl_3 and polymers were added to the wastewater indicates that the removal of solids in a primary settling tank is extremely rapid once flocs are properly formed by chemical coagulation.

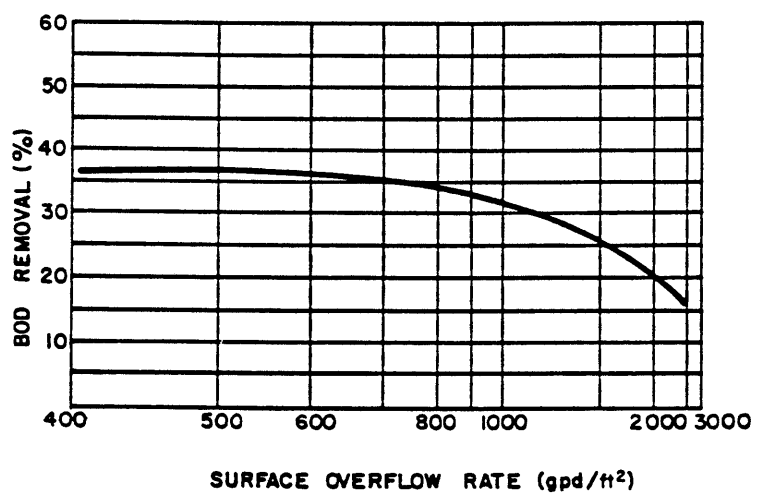
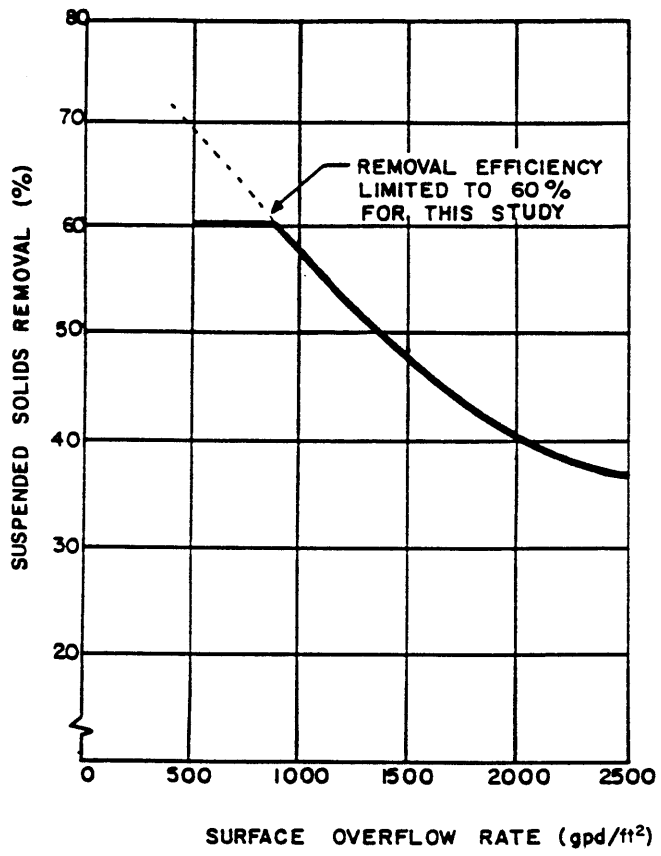

Figure 4.1: Design Overflow Rate for TSS and BOD₅ Removals in Primary Clarifiers (WPCF, 1985)

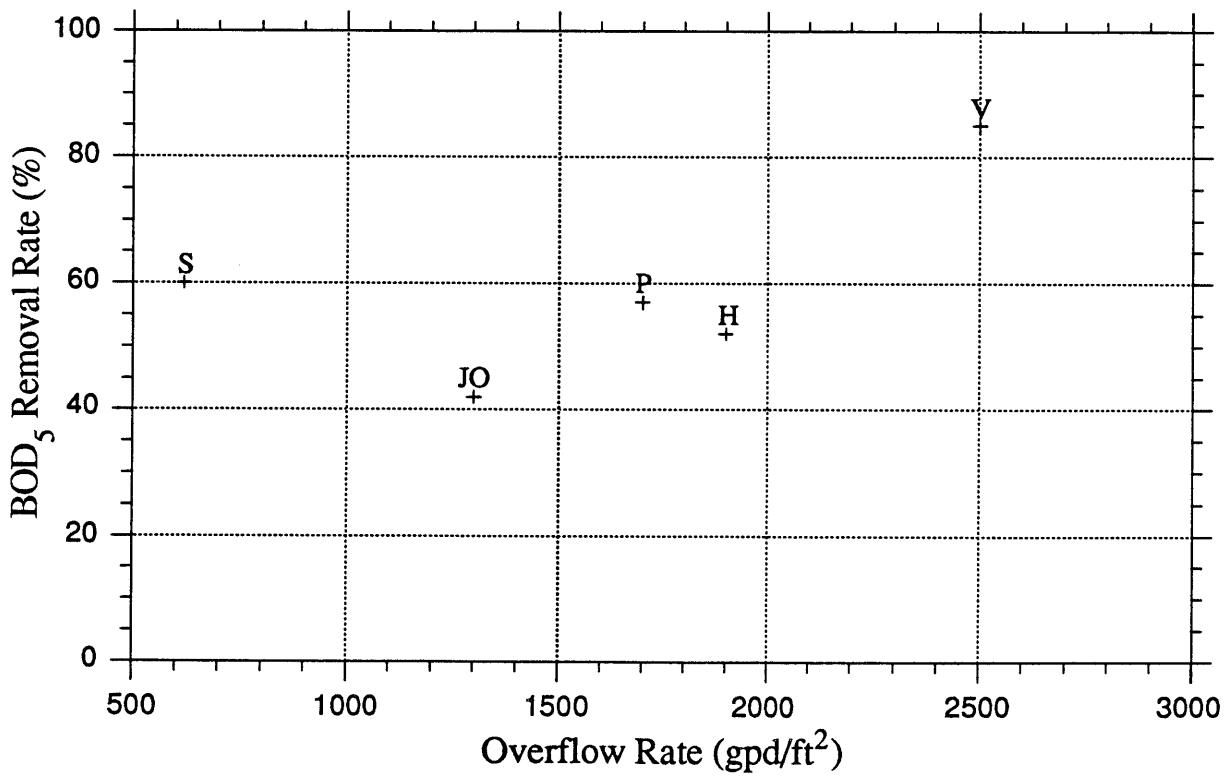
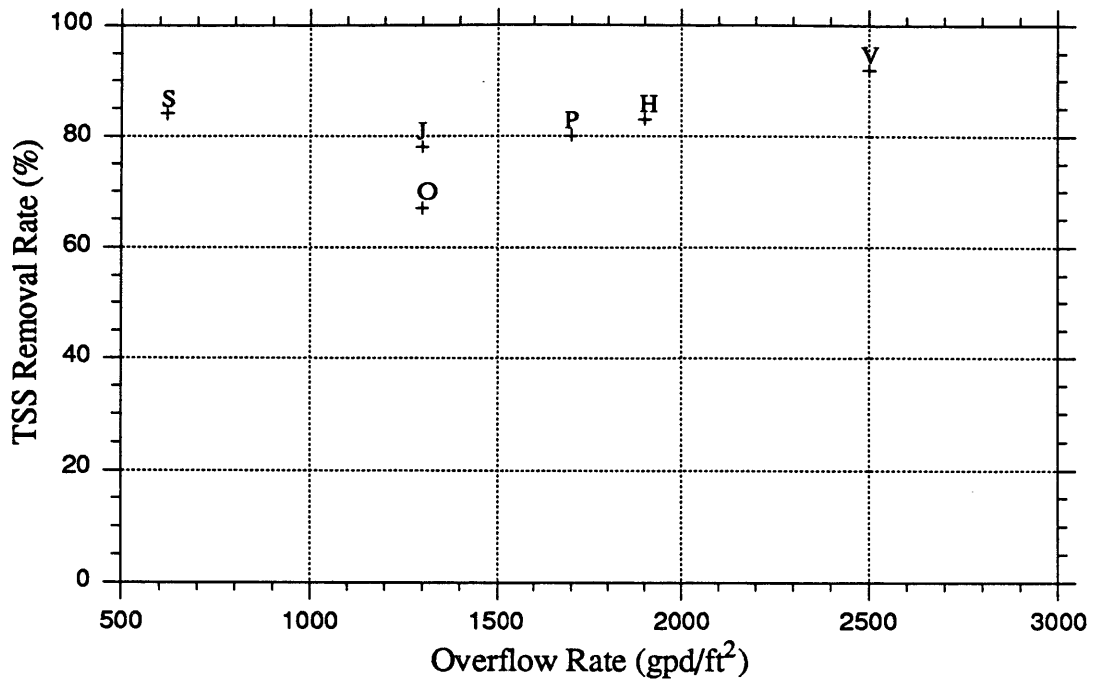

Figure 4.2: Overflow Rate for TSS and BOD₅ Removals for Existing Chemically-Enhanced Treatment Facilities

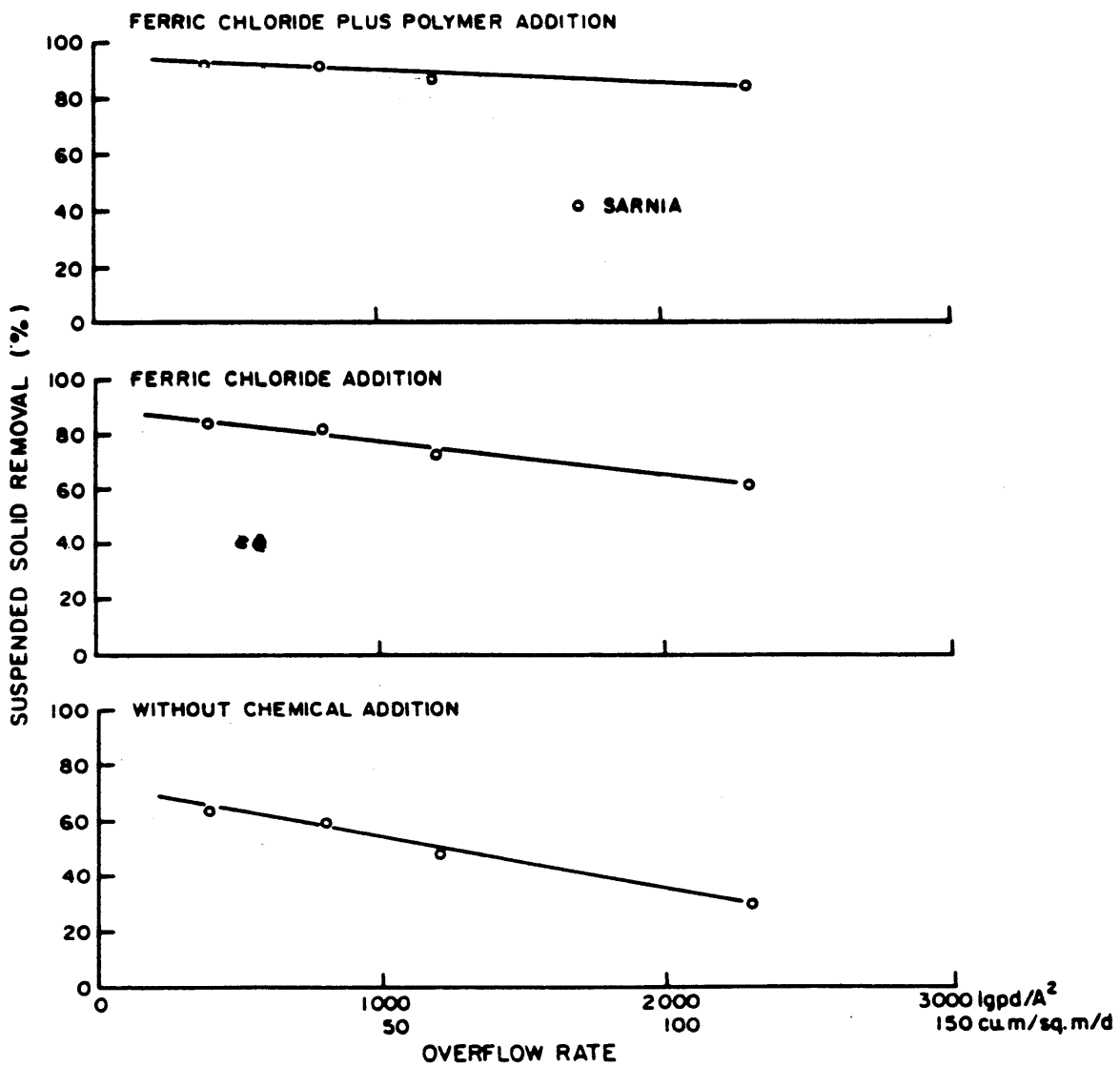

Figure 4.3: Overflow Rate Verses TSS Removal for Sarnia Treatment Plant (Hienke, et al. 1983)

At the South Essex Sewerage District (SESD) plant in Salem, Massachusetts a study was conducted to determine whether chemical addition would improve the performance efficiency at the primary treatment plant (Morrissey and Harleman, May 1990). Data from this study indicated that for overflow rates greater than 2000 gpd/ft² there was no deterioration in BOD₅ removal rates (Figure 4.4).

Based on the data presented in Figures 4.2, 4.3, and 4.4, when chemicals are added to the primary clarifier, the clarifiers performed better. The following should be noted:

- Chemical addition can accommodate the increase in flow and loading within a small area eliminating the need for large capital investment caused by constructing new clarifiers. Previously, to obtain 60% TSS and 35% BOD₅ removal rates, an overflow rate of approximately 800 gpd/ft² was needed. Now, if chemicals are properly added, overflow rates of 2500 gpd/ft² can be maintained while achieving removal rates higher than 60% TSS and 35% BOD₅.
- Higher removal rates can be obtained in an existing facility reducing or eliminating the need for a biological process.

4.3 Biochemical Oxidation Rate

When chemicals are used to enhance settling in the primary clarifiers, an increase in removal efficiency results. This increase in efficiency results from the removal of colloidal size particle that aggregate and settled out. As seen in Figure 1.2, the maximum size of the particles that can be removed by coagulation is approximately 0.1 μm. Conventional primary treatment removes particles larger than 40 μm. Table 4.1 shows the size distribution of particles in wastewater and the pollutants associated with each size category. Also shown in this table are the biochemical oxidation rates (k_1) associated with each size category. As seen, the microorganisms can more easily oxidize the organic matter associated with smaller particles. In particular, particles smaller than 1.0 μm have a two to four fold increase in k_1 over particles >40 μm.

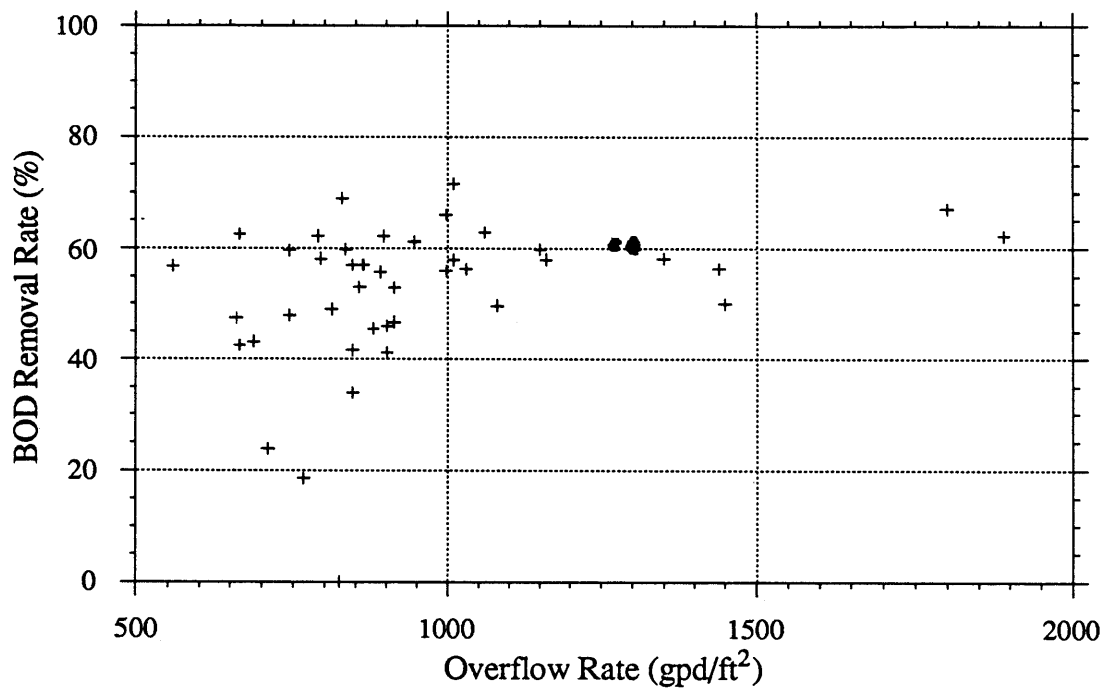

Figure 4.4: Overflow Rate versus BOD₅ Removal for SESD During Chemical Testing From March 25 1990 Through April 16, 1990 (Morrissey and Harleman, May, 1990)

Table 4.1: Composition of Organic Material in Wastewater

	Soluble	Colloidal	Supracolloidal	Settleable
Size Range	<0.08 μm	0.08-1.0 μm	1-100 μm	>100 μm
COD (% of tot)	25	15	26	34
TOC (% of tot)	31	14	24	31
Grease (% of tot)	12	51	24	19
k_1 (day ⁻¹)	0.39	0.22	0.09	0.08

Source: Odegaard, 1989

In the following section, the importance of the biochemical oxidation rate on biological processes will be emphasized; however, additional research in this area is needed.

4.4 Advanced Primary Treatment

Advanced primary treatment (APT) usually done with minimal additional construction to conventional primary treatment plants; therefore, little capital cost is needed to convert a primary treatment plant to an APT plant. This treatment consists of adding metal salts (ie. alum or ferric chloride) and an anionic polymer to the wastestream to enhance settling. The metal salt, which is used as a coagulating agent, needs rapid mixing to optimize the coagulation process. The metal salt (at a concentration of 20-30 mg/l) should be added as far upstream of the sedimentation tanks as possible to allow enough mixing time for the coagulation process to occur. The anionic polymer needs rapid mixing initially to dilute the polymer, then gentle mixing to promote flocculation and the formation of large settleable flocs. The anionic polymer (0.2-0.3 mg/l) should be added before the sedimentation tanks. This type of treatment has consistently achieved 80% TSS, 50-60% BOD₅, and 80% phosphorus removals. This type of process does not normally achieve secondary standards; therefore, additional treatment may be required. In this section, the implications APT has on both an activated sludge and a trickling filter system will be discussed.

It is understood that many of the equations presented in this chapter and used in designing secondary biological treatment facilities are empirical in nature and based on conventional primary effluent characteristics. Therefore, these equations may not be entirely appropriate for dilute influent from a chemically-enhanced treatment process; however, they are used here to illustrate that chemically-treated effluent dramatically reduces the size requirements of any additional treatment to the wastewater.

4.4.1 Advanced Primary Treatment Followed by an Activated Sludge Process

The activated sludge (AS) process consists of aeration basins, settling tanks, and return sludge equipment. The mechanisms involved in the removal of pollutants are the transformation of colloidal and dissolved organic particles into bacterial life and growth functions, flocculation, and sedimentation. To transform the soluble fraction and organic particles (substrate) into bacterial growth and energy, oxygen is needed. If the oxygen is not sufficient, the process will fail. Therefore, the AS process is operated so that it is substrate limiting. Flocculation occurs naturally because of the affinity of the biomass, which causes particles to settle more rapidly in settling tanks.

Two types of AS systems are prevalent in the United States: the conventional air system and a high purity oxygen (HPO) system. There has been considerable controversy as to the advantages of one system over the other. It is instructive to look at the following benefits stated for a HPO system over an air system (ASCE, 1983):

- 1) A reduction in the power required for the aeration system.
- 2) Increased rate of substrate utilization.
- 3) Reduction or elimination of periods of zero DO concentrations.
- 4) Reduction in plant size, and thus, capital investments.
- 5) Increased capacity for organically overloaded plants without need for additional aerator capacity.

The primary debate over the years between HPO and air AS system has focused on the oxidation rate (number 2 above) which in turn affects numbers 4 and 5. It is claimed that microorganisms can oxidize the organic matter more readily because of higher oxygen concentrations (ASCE, 1983). The result of this is that smaller plants can process higher BOD loads. This same rationale applies to chemically-enhanced effluent because the

particle size has been significantly reduced causing a higher oxidation rate. The higher oxidation rate is due to the microorganisms' ability to oxidize smaller particles more easily than larger particles.

Currently, the design value used for k_1 is approximately 0.1 day^{-1} based on oxidation rates for effluent from conventional primary treatment. When chemicals are added to the primary clarifiers, the results are a reduction in the size of the particles in the effluent. As seen in Table 4.1, smaller size particles have higher k_1 values. This notion of increased k_1 values when chemicals are added has been shown at the Hyperion treatment plant (Shao, et al., 1990). Hyperion has been able to increase the flow capacity through their existing air AS system from 100 mgd to 150 mgd solely by adding chemicals to the primary clarifiers.

To illustrate the notion of reducing the size requirements of an activated sludge system by a reduction in the BOD loading, the concept of a constant food-to-microorganism (F:M) ratio is used. The equation to calculate F:M is given below:

$$F:M = (\text{BOD}_{5a} \cdot Q) / (\text{MLVSS} \cdot V) \quad (4.1)$$

where:

- F:M = food-to-microorganism ratio (kg BOD_{5a} / kg MLVSS / day)
- BOD_{5a} = five day BOD loading entering the AS system (mg/l)
- Q = flow rate (m³/day)
- MLVSS = mixed liquor volatile suspended solids (mg/l)
- V = volume of aeration basin (m³)

From equation 4.1, it can be seen that if the flow and F:M ratio are keep constant and BOD_{5a} decreases, the MLVSS or the volume of the aeration tank must also decrease. This point is illustrated in Table 4.2 where F:M is 0.6 kg BOD_{5a}/kg MLVSS, MLVSS is 3500 mg/l, and the flow rate is 100,000 m³/day.

**Table 4.2: Volume Requirements for an Activated Sludge Aeration Basin
Based on BOD Loading**

BOD _{5a} (mg/l)	V (1000 ft ³)
160	269
140	235
120	202
100	168
80	134

If a treatment facility with an existing AS plant is required to provide nitrification, an obvious option would be to add chemicals to the primary clarifiers. This would reduce the volumetric requirements of the aeration basins allowing additional retention time so that the slower autotrophic bacteria could work before being washed out and nitrification could occur. This has been observed in countries such as Sweden and Norway (Karlsson, 1988).

4.4.2 Advanced Primary Treatment Followed by a Trickling Filters Process

The trickling filter process consists of filter media in an enclosed (not necessarily covered) basin where wastewater is distributed over the media (Figure 4.5), sludge recycling equipment (if required), and settling tanks. The mechanisms involved in the removal of pollutants are the transformation of colloidal and dissolved organic particles into bacterial life and growth functions. In this process, the microorganisms adhere to the media. Once the build-up of the organisms is too great, they slough-off and this sludge is either pumped to the primary clarifiers, the beginning of the trickling filter, or an addition clarifier.

There are two basic types of media used for trickling filters: stone media and synthetic media. The synthetic media is advantageous over the stone media because synthetic media are light weight, have a large specific surface area so there is a greater amount of biomass per unit volume, and have a greater pore space for higher hydraulic loading without restriction of oxygen transfer.

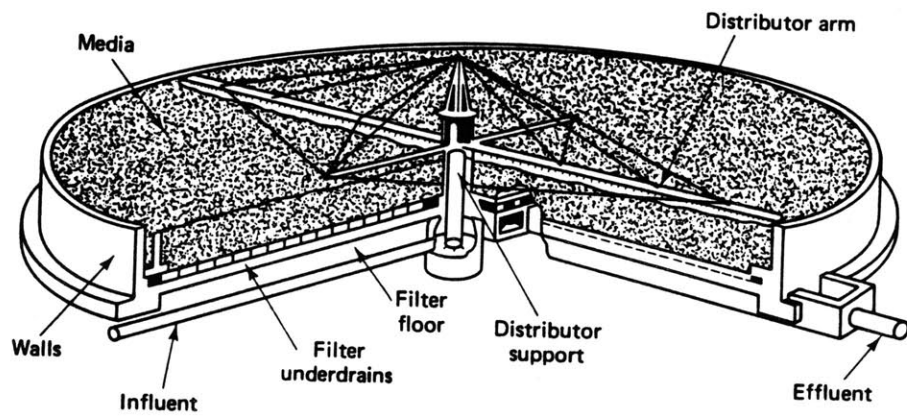

Figure 4.5: Cross Section of a Trickling Filter (Benfield and Randall, 1980)

An important design parameter used in sizing a trickling filter is the incoming BOD. The National Research Council (NRC, 1946) has developed an empirical design equation for stone media trickling filters (eq. 4.2). This equation has been rearranged (Baker and Graves, 1968) in order to more easily determine the volume of media needed to treat a given influent BOD concentration (eq. 4.4). Table 4.3 has been developed based on these equations to show the impact chemical addition can have on sizing a trickling filter. For Table 4.3, it was assumed that the trickling filter effluent concentration was required to be 30 mg/l and the primary influent BOD₅ concentration was 200 mg/l. This results were an overall removal rate of 85% for the entire plant.

$$E = 1 / (1 + 0.0561 \cdot (S_0 / (V \cdot F))^{0.5}) \quad (4.2)$$

$$F = (1+R) / (1 + 0.1R)^2 \quad (4.3)$$

$$V = 0.0263 \cdot Q \cdot S_0 \cdot [((1 + 0.1R)^2 / (1 + R)) \cdot (E / (1-E))^2] \quad (4.4)$$

$$E = 100 \cdot [(S_0 - 30) / S_0] \quad (4.5)$$

where: V = volume of media (m³)
 Q = flow (100,000 m³/day = 26.4 mgd)
 S₀ = influent BOD entering trickling filter after pre-treatment (mg/l)
 R = recirculation rate (4), the rate of recycle divided by the rate of inflow to the filter
 E = required removal efficiency to obtain effluent BOD concentration of 30 mg/l

Table 4.3: Volume Requirements for Tricking Filters Based on BOD Loading

S ₀ (mg/l)	R _a (%)	E (%)	V (1000 ft ³)
160	20	81	780
140	30	79	530
120	40	75	290
100	50	70	150
80	60	63	60

Note: R_a is the removal rate obtained during pre-treatment.

As seen, there is a ten fold reduction in the size of the trickling filter if 60% versus 20% of the incoming BOD to the plant is removed by pre-treatment. If an existing trickling filter plant is needed to provide nitrification, an obvious option would be to add chemicals to the primary clarifiers. With a trickling filter, nitrification starts when most of the organic matter is consumed while the number of fast growing heterotrophs start to decrease and the number of slower growing autotrophs increase. One parameter used to determine if nitrification will occur is the BOD/N ratio. When this ratio is high, large volumes and surfaces areas are required. The lower the BOD/N ratio, the smaller the surface area required to achieve nitrification (Karlsson, 1988).

By comparing the volume requirements for trickling filter and an AS aeration basin (Table 4.4), it can be seen that for high BOD loadings the AS system requires much less space. However, if the BOD loading is low (from a chemically-enhanced process), trickling filters occupy less space than the AS aeration basin. Figure 4.6 shows this relationship. Based on this comparison, with chemically-enhanced treatment, trickling filters become much more attractive due to the reduction in cost and the simplicity of operations for meeting secondary standards.

Table 4.4: Comparison of Volume Requirements for Activated Sludge Aeration Basins and Tricking Filters Based on BOD Loading

S_o (mg/l)	AS Volume (1000 ft ³)	TF Volume (1000 ft ³)
160	269	780
140	235	530
120	202	290
100	168	150
80	134	60

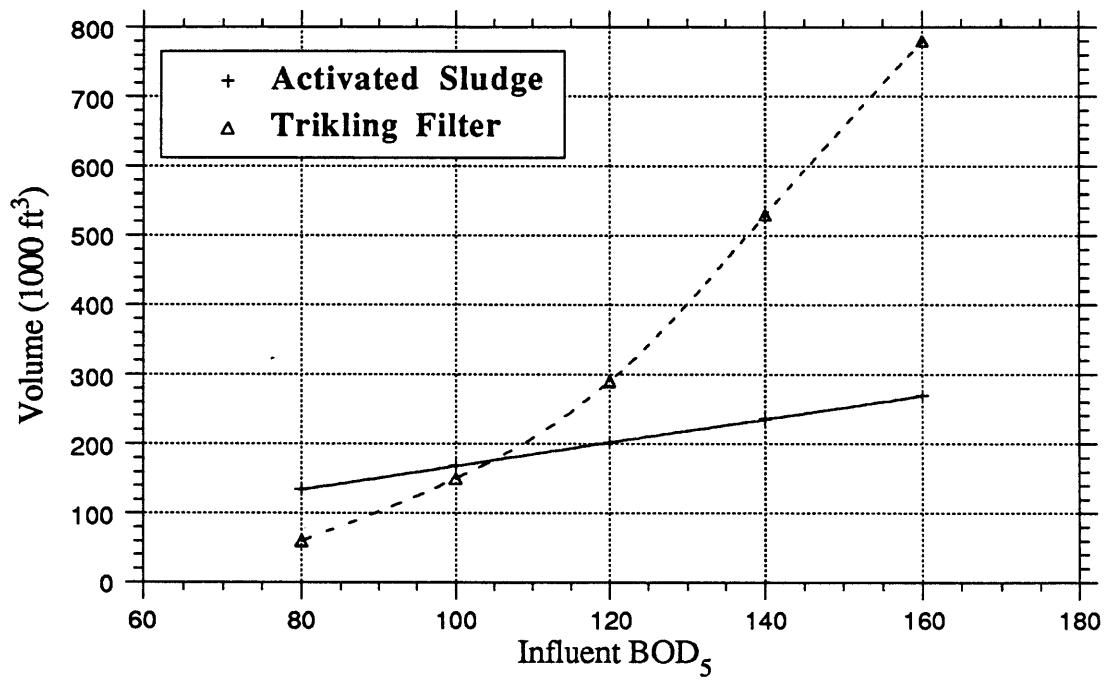

Figure 4.6: Comparison of Volume Requirements for Trickling Filters and Activated Sludge Systems Based on Various Incoming BOD₅ Concentrations

4.5 Single Stage Chemical Secondary Treatment

Single stage chemical secondary treatment is being used in Norway and Sweden in plants designed to optimize the chemical treatment process and remove phosphorus. The treatment consists of adding about 150 mg/l of metal salt and 0.2-0.3 mg/l of an anionic polymer. The difference between this type of treatment and advanced primary is that in the chemical secondary process, flocculation basins are provided before the sedimentation tanks to maximize the flocculation process. These flocculation basins are in series, with the mixing rates becoming progressively slower as the wastewater approaches the sedimentation tanks. The metal salt is added approximately 20 minutes upstream of the flocculation basins. The anionic polymer is added before the flocculation basins and is mixed with the wastewater and metals salt for approximately 30 minutes before reaching the sedimentation tanks. This type of treatment has consistently achieved 90% TSS, 80% BOD, and 95% phosphorus removals (Odegaard, 1988). Currently, the Oslo plant is experimenting with eliminating the flocculation basins by developing more effective rapid mixing devices. Other Norwegian plants still contend that the flocculation basins are essential.

The Scandinavian countries are concerned with phosphorus (P) removal and are currently required to remove 95% of total P. By the end of 1990, they will be required to remove 97% of total P. High P removal is required because it is believed to be the limiting nutrient for algal growth in their coastal waters. Therefore, P removal has driven much of the treatment technology in the past decade in Scandinavia. Along with high P removals, these treatment processes have also experienced high solids removals (>90%) and high BOD removals (75-85%). The Scandinavians' experience with wastewater treatment is extremely interesting and needs to be further investigated, not necessarily for high P or solids removals, but in terms of BOD removals and changes in the biochemical oxidation rate (k_1).

In this section, the following question will be addressed: why do the Scandinavian treatment plants use large quantities of metal salts? It is important to realize that additional research is required to fully answer this question, but a reasonable explanation will be provided below.

4.5.1 Chemical Concentration

As stated above, treatment plants in Scandinavia are primarily concerned with P removals. Because of this, high concentrations of metal salts are needed. To illustrate this point, an analysis of the amount of alum needed to remove a given amount of P is given.

The aluminum ions (Al^{3+}) react with phosphate ions (PO_4^{3-}) to form aluminum phosphate ($AlPO_4$) resulting in a mole ratio (Al:P) of 1:1 and a weight ratio (Al:P) of 0.87. Noting that alum contains 9.1% Al results in a requirement of 9.6 pounds of alum to remove 1.0 pound of P. The pH of the wastewater can dramatically affect the removal efficiencies with optimum removals resulting when the pH is between 5.5 and 6.5 (Stumm & Morgan, 1970). Experiments have shown that higher than stoichiometric quantities of alum are needed for the complete reaction to occur. Table 4.5 shows the pounds of alum required to remove one pound of P when a given removal efficiency is required.

Table 4.5: Alum Requirement for a Given Phosphorus Removal Rate

P reduction required	lbs alum required to removal 1 lb of P
75%	13
85%	16
95%	22

Source: EPA, 1976

Figure 4.7 is a plot of the P removal rate verses pounds of alum required to remove one pound of P as shown in Table 4.5. This figure further illustrates the exponential requirement of alum for high P removal.

The same shape as in Figure 4.7 is observed when a metal salt is used indicating that removing an incremental amount of P beyond 75% requires very large concentrations of any metal salt.

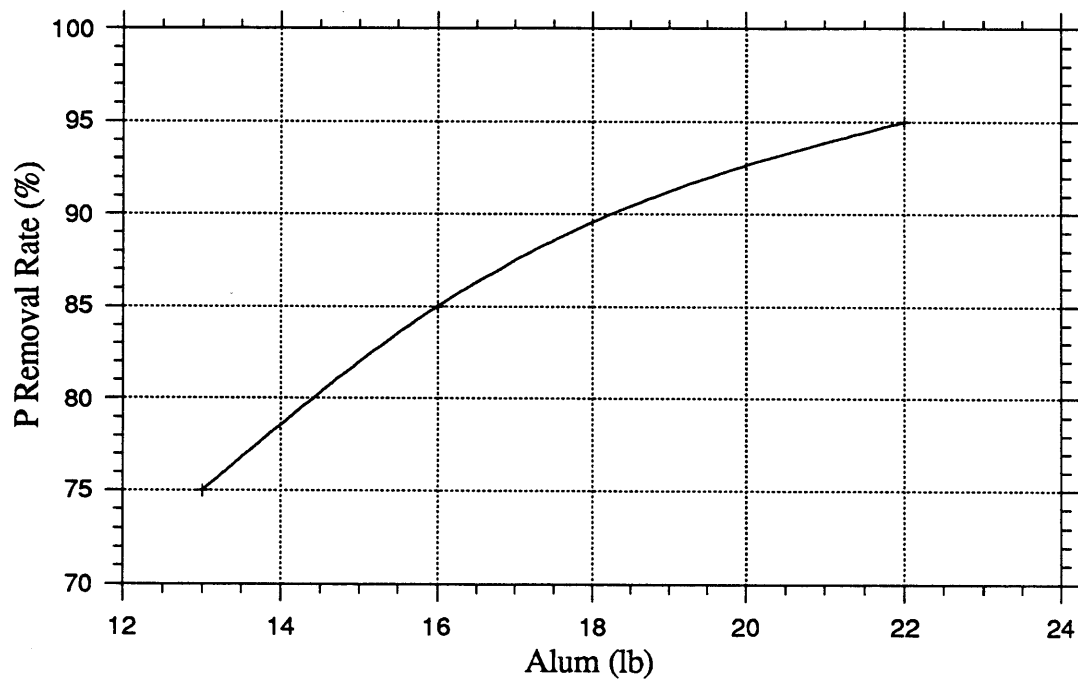

Figure 4.7: Amount of Alum Required to Remove Phosphorus

It is important to realize from this discussion that Scandinavia uses high concentrations of metal salts to remove high quantities of P – not to remove high quantities of TSS and BOD (see Chapter 2). However, it is unclear whether beneficial reactions take place due to high concentrations of metal salts in terms of toxic removal. Additional work in this area is essential.

4.6 Sludge

Sludge is the by-product of any treatment process that removes solids from the waste stream. If chemicals or biomass precipitate in the settling tanks, they become incorporated into the sludge. The sludge produced during wastewater treatment precipitation has higher water content and is very voluminous. In order to reduce the volume, sludge is thickened and dewatered by various means. After the volume has been reduced, the sludge must be disposed of in an appropriate manner.

In this section, the effects of chemical addition on various aspects of sludge production, processing, and disposal will be discussed. Comparisons to conventional primary and biological treatment processes will be made when appropriate.

4.6.1 Sludge Production

The amount of dry sludge produced by the chemical treatment process can be calculated as shown below.

$$R_s = Q \cdot (TSS_{in} - TSS_{out}) + \sum K_i \cdot C \quad (4.6)$$

where:

- R_s = rate of sludge production (dry-lb/day)
- Q = average flow rate (mgd)
- TSS_{in} = influent TSS concentration (mg/l)
- TSS_{out} = effluent TSS concentration (mg/l)
- K_i = the concentration of chemical i that precipitates (mg/l)
- C = unit conversion constant (8.34 (lb/day) / (mgd)(mg/l))

The solids concentration can be determined based on the difference between the influent and effluent TSS concentrations and the concentrations of chemicals added to the wastewater. The equation for the solids concentration in the sludge after sedimentation is as follows:

$$S_c = (TSS_{in} - TSS_{out}) + \sum K_i \quad (4.7)$$

where: S_c = solids concentration in the sludge after sedimentation (mg/l)

Other equations have been developed (Hansson, 1985) that include phosphorus removal in the mass balance. This type of equation is most appropriate when very large concentrations of a metal salt are used.

To determine the concentration of the chemical that will be removed, it is necessary to know the chemical reactions involved for each chemical. For the polymers, this information is very hard to obtain due to the complexities of the compounds and their reactions. It is assumed that 100% of the polymers added will be removed and found in the sludge.

The chemical reaction for $FeCl_3$ is given below:

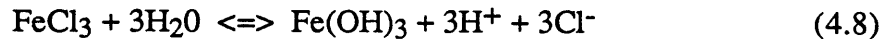

The molecular weight of $FeCl_3$ is 162.1 g/mol, and 106.9 g/mol for ferric hydroxide ($Fe(OH)_3$). Therefore, 66% of the $FeCl_3$ (by weight) will precipitate out as $Fe(OH)_3$.

For example, if the average flow is 100 mgd, the TSS influent concentration is 200 mg/l, the TSS effluent concentration is 30 mg/l, 20 ppm of $FeCl_3$ is added, 5 ppm of a cationic polymer is added, and 0.4 ppm of an anionic polymer is added, the solids concentration can be determined using equation (4.7).

$$S_c = (TSS_{in} - TSS_{out}) + \sum K_i$$

$$S_c = (200 \text{ mg/l} - 30 \text{ mg/l}) + (.66 \cdot 20 \text{ mg/l}) + 5 \text{ mg/l} + 0.4 \text{ mg/l}$$

$$S_c = 189 \text{ mg/l}$$

Given the solids concentration, the amount of dry solids in the sludge can be calculated using equation (4.6).

$$R_s = Q \cdot S_c \cdot C$$

$$R_s = (100 \text{ mgd}) \cdot (189 \text{ mg/l}) \cdot 8.34$$

$$R_s = 157,300 \text{ dry-lb / day}$$

$$R_s = 78.7 \text{ dry-tons / day}$$

4.6.2 Sludge Processing

Regardless of the treatment process used, sludge will be produced. This sludge has a large amount of water trapped between the solids and is voluminous. Before disposing of the sludge, it is desirable to reduce the amount of water associated with the solids; hence, reducing its volume. In this section, the relationship between solids content and volume will be discussed along with various methods for processing the sludge.

4.6.2.1 Solids Content

As the solids settle, water is trapped forming a sludge blanket on the bottom of the settling tanks. The solids content of the sludge is a operational control parameter that is used to determine when to pump sludge from the settling tanks. Typical values for conventional treatment processes are given in Table 4.6.

Table 4.6: Typical Solids Content of Sludge Resulting From Various Conventional Treatment Processes

Treatment Process	Typical solids content (%)
Conv. Primary	5.0
Conv. Prim + HPO Activated Sludge	4.0
Conv. Prim. + Trickling Filter	5.0
HPO Activated Sludge	1.25
Trickling Filter	1.5

Source: M&E, 1979

Based on the solids content of the sludge, the volume of sludge can be determined. The volume of sludge is important because once the sludge is pumped, the sludge is stored until processing; hence, it is a parameter used in sizing storage bins. Equation 4.9 shows how volume is calculated from solids content.

$$V_s = [R_s / (C \cdot S_g)] + [(R_s \cdot ((100 - S_c) / S_c)) / C] \quad (4.9)$$

where:

- V_s = volume of sludge produced (gal)
- R_s = rate of sludge production (dry-lb/day)
- C = unit conversion constant (8.33 dry-lb/gal)
- S_g = specific gravity of solids (assumed to be 2.0)
- S_c = solids content of sludge (%)

As an example, if the rate of sludge production is 20,000 lb/day and the solids content is varied, Table 4.7 is produced.

Table 4.7: Volume of Sludge Resulting From a Change in the Solids Content

Solids Content (%)	Volume of sludge (gal)	% increase in sludge produced by reducing the solids content by one
1	239,000	101
2	119,000	51
3	79,000	34
4	59,000	26
5	47,000	21
6	39,000	

As seen from this table, a reduction in the solids content significantly increases the volume of sludge produced.

Currently, there are a number of facilities treating their wastewater with chemicals (see Chapter 2). Table 4.8 shows a few of these facilities, the treatment process used, and the solids content of their sludge.

Table 4.8: Solids Content of the Sludge Produced at Various Advanced Primary Treatment Facilities

Facility	Treatment Process	Solids content (%)
Pt. Loma, San Diego	APT	5.8
Hyperion, LA	100% APT + 45% AS	4.2
Sarnia, Ontario	APT	5.0

The only treatment facility that has data comparing sludge production for conventional primary and advanced primary treatment is SESD. SESD has run a series of full scale tests (see Chapter 3) where only one half of the plant was treated with chemicals and the other was used as a control. The solids content is given in Table 4.9 for the treated and untreated (control) sides of the plant at SESD.

Table 4.9: Comparison of SESD's Sludge Solids Content During Chemical Testing (March 25 - April 16)

	Solids Content (%)
Chemically-Treated	4.8
Untreated	4.4

4.6.2.2 Sludge Conditioning

Depending on the sludge dewatering process, the sludge is often conditioned with chemicals to aid in the dewatering process. At SESD, a cationic polymer is added to the sludge before it is dewatered on a belt filter press. When chemicals were added to the wastewater, the amount of cationic polymer increased slightly (Morrissey and Harleman, March 1990). When the chemical treatment process continues on a permanent basis, different polymers should be investigated based on the different characteristics of the chemical sludge; hence, reducing the requirements for additional polymers for conditioning.

4.6.2.3 Digestion

Sludge produced by chemical addition to the wastewater can be digested anaerobically. An anaerobic process is a biological process in the absence of oxygen. Anaerobic digestion stabilizes the sludge by decomposing organic and inorganic matter into methane (CH₄) and carbon dioxide (CO₂).

Table 4.10 shows the treatment process, the solids content, and the percentage of volatile solids in the sludge at different treatment facilities. Only two of the facilities listed (Point Loma and Sarnia) digest sludge that results from advanced primary treatment. The others digest sludge resulting from chemical and biological treatment.

Table 4.10: Sludge Characteristics at Various Treatment Facilities

Location	Sludge	Solids Content (%)	Volatile Content (%)
Sarnia	Raw (APT)	5	61
	Digested	10	46
Point Loma	Raw (APT)	5.8	71
	Digested	3.3	54
Hyperion	Raw (Combined)	4.2	76
	Digested	2.3	59
Orange County	Raw (P + APT)	5.1	73
	Digested	3.1	60
	Raw (Combined)	2.9	87
	Digested	2.6	61

There has been no reported disadvantage to digesting sludge resulting from chemical treatment when ferric chloride is used. On the contrary, according to some of the operations people at these facilities, the addition of ferric chloride has aided the digestion process since iron is often added to help digestion. However, when alum (Al(SO₄)₃ + 18 H₂O) is used in the chemical treatment process, an excessive amount of sulfur gas has been reported. Due to air quality standards, this was a problem at Orange County. With air emission control techniques available, this should not pose any technical problem.

Due to the increase in organic matter removed, more methane gas will be produced by digestion. This gas can readily be converted to energy and used for plant operations resulting in a significant reduction in energy costs.

4.6.2.4 Dewatering

Dewatering is a physical process that reduces the moisture content of the sludge. There are a number of processes available to dewater sludge and they include filters, centrifuges, drying beds, and lagoons. Each of these processes have been used to dewater sludge resulting from chemical treatment. Table 4.11 shows the type of dewatering processes and the percent solids in the dry cake produced by different treatment facilities.

Table 4.11: Dewatering Characteristics at Various Treatment Facilities

Location	Dewatering Process	% solids in cake
Point Loma	Drying beds	NA
Sarnia	Lagoons	NA
Hyperion	Centrifuge	20
Orange County	Filter presses	22
Oslo	Filter press	34
LA County	Centrifuge	23

SESD is the only treatment facility that has data comparing the dewatering of sludge that resulted from two different treatment processes (Morrissey and Harleman, 1990). Table 4.12 shows values of the solids cake resulting from dewatering using a filter belt press. The treated side of the plant had chemicals added and the untreated(control) side had no chemicals added.

Table 4.12: Dewatering Solid Cake Comparison at SESD

	Solids Content of Cake (%)
Chemically-Treated	29
Untreated	32

4.6.3 Sludge Disposal

There are three major modes of disposing sludge: water, air, and land. Currently, disposal of sludge into the water (ocean) is being phased out with the Ocean Dumping Act of 1972, which prohibits the disposal of sewage sludge into the ocean after December 31, 1991. Air disposal results from incineration, which is always coupled with another form of disposal due to the ash by-product that is produced. Land disposal includes landfilling of the sludge and use of sludge as a soil conditioner. Land disposal is by far the most prevalent form of disposal and will be the focus of the following discussion.

4.6.3.1 Land Disposal of Sludge

Landfilling, composting, and heat drying are the most prevalent forms of sludge disposal on the land. Landfilling is the disposal of material on land by burial. This is a final disposal technique unless chemical treatment and/or some future recovery method is planned. This disposal technique is widely practiced throughout the U.S. and requires a lot of land and increased monitoring practices. A primary consideration when designing landfills for sludge is its potential for groundwater contamination.

Chemical treatment of sludge includes the addition of chemicals to improve the handling and physical characteristics of the sludge. One form of chemical treatment is to add reagents, polymers, and portland cement. This raises the pH to approximately 12, which destroys pathogens, inhibits the transfer or loss of contained pollutants, and limiting the solubility of pollutants. This chemically-fixed sludge is often used as a landfill cover. Chemical fixation of sludge resulting from a chemically-enhanced wastewater treatment process and from a conventional primary treatment process is very similar as seen at the SESD primary treatment plant (Morrissey and Harleman, March 1990).

JWPCP in Los Angeles County is using an innovative method for recovery the methane gas produced from the decomposition of landfilled sludge. They have developed a series of methane gas collection pipes that are covered by sludge. As the gas is produced, it is collected and used to generate power for the surrounding communities. This landfill contains sludge that is the result of chemically-enhanced wastewater treatment.

Composting is a form of stabilization where sludge is decomposed by microorganisms in the presence of oxygen. Amendments, such as sawdust or woodchips, are added to the sludge to increase porosity so that air can enter to encourage microorganism growth. This results in an increase in total solids concentration and a decrease in pollutant concentration. In the presence of air, microorganisms multiply by breaking down the organic material in the sludge causing heat, reducing the volume, and converting of a waste into a resource. Composters will reach temperatures of 50° to 70° C, which is hot enough to kill harmful viruses and bacteria. The problems associated with composting are as follows:

- increased concentration of contaminants in composted sludge due to a decrease in volume
- production of offensive odors
- treating groundwater contamination resulting from leachate
- generation of compost leachate

Composted sludge has been used as a soil conditioner in areas such as:

- landscaping
- enhancement of highways with media strips
- greenhouse and nurseries
- land reclamation

Composting of sludge from chemically-enhanced wastewater treatment is used at the JWPCP in Los Angeles County and at a number of Scandinavian treatment plants. The JWPCP sells their composted sludge as a soil conditioner to greenhouses and nurseries with no adverse affects. Scandinavian plants use their composted sludge as a soil conditioner and a fertilizer. It has been shown (Hansson, 1985 and Kemira, 1989) that sludge resulting from chemically-enhanced wastewater treatment is very beneficial both in terms of its nutrient content, in particular its phosphorus content, and its ability to increase the stability of the soil structure which reduces the hazards of erosion for land reclamation. One of the major concerns with composted sludge is the concentration of contaminants. This concentration is increased in sludge composted from chemically-enhanced wastewater treatment (over biological secondary treatment) due to the decrease in volume of the sludge

generated and a similar amount of contaminants removed. A proper source control program is the obvious answer to this problem.

Heat drying involves heating the sludge in tank-like dryers. This process removes moisture through evaporation and greatly reduces the volume of sludge. Heat drying is done at a temperature that kills harmful viruses and bacteria. After heat drying, the sludge can be formed into pellets for ease of transport. The problems associated with heat drying are:

- increased concentration of contaminants in dried sludge due to a decrease in volume
- production of offensive odors
- high energy costs

Heat dried sludge can be used as a fertilizer in areas such as:

- golf courses
- sod farms
- horticultural uses
- agricultural uses
- forest areas

There is no facility, to the author's knowledge, that is heat drying sludge produced by chemically-enhanced wastewater treatment. The parameters used to determine if a sludge is suitable for heat-drying are:

- contaminant concentration
- volatile solids content
- total solids content
- conventional pollutants

4.7 Costs Associated With Chemically-Enhanced Wastewater Treatment

Costs associated with any treatment process can be discussed in terms of operations and maintenance (O&M) and capital costs. The primary O&M costs associated with chemical treatment are chemical costs, energy, labor, and maintenance of equipment. The primary capital costs are associated with the construction and equipment needed for the plant. Both O&M and capital costs will be discussed below in terms of advanced primary and chemical secondary treatment. Comparison to conventional primary and biological secondary will be made when appropriate. Sludge costs will be treated separately in section 4.7.3.

4.7.1 O&M Costs

O&M costs for chemical treatment include chemical costs, energy, labor, and maintenance of equipment. Costs to maintain equipment is directly related to the amount of equipment needed to run a treatment facility and the complexity of that equipment. Additional equipment needed beyond what is required for a conventional primary treatment plant is minimal for an APT facility and includes chemical feed systems (pumps, storage tanks, electronic signal equipment, and piping). This equipment is easily maintained. For a chemical secondary treatment facility, the same equipment is needed as with an APT facility plus flocculation basins and mixing devices. Again, this equipment is easy to maintain. If a biological treatment plant (ie. a HPO system) is used, the type of equipment needed beyond a conventional primary facility includes aeration tanks, oxygen storage tanks, mixing devices, settling tanks, return sludge devices, pumps, piping, and electronic signal devices. The major problem with biological secondary treatment is the amount of equipment to maintain and the complexity of all the parts.

Labor costs are related to the complexity of the treatment process. Both the advanced primary and chemical secondary treatment processes are fairly simple in comparison with a biological treatment process (HPO system). Therefore, the HPO system requires more skilled laborers which requires more pay.

An excellent analysis of energy costs associated with BOD reduction has been done by Karlsson (1985) and is used here to illustrate the savings that can occur with chemical treatment.

Figure 4.8 shows the energy consumption required for biological treatment in terms of variations in BOD loadings resulting from adding chemicals to the primary influent. It should be noted that there are costs associated with injecting the chemicals; however, these costs are minor compared to the costs associated with biological treatment. It is assumed that it takes 1.3 kWh to remove 1 kg of BOD and the cost of energy is \$0.063 / kWh. By reducing the BOD loading onto the biological treatment process by 75%, the consumption of energy of the biological process is also reduced by 75%. This reduction in energy costs makes the chemically-enhanced treatment process more cost effective.

Chemical costs are the major O&M costs associated with chemical treatment. The increase in the O&M costs for chemical treatment are less than the O&M costs associated with activated sludge systems.

Table 4.13 shows the weight and cost associated with various chemicals used in the chemical treatment process. Equation 4.10 shows how to calculate wet-weight from dry-weight. As an example, if alum weighs 5.4 lb/gal on a dry basis and the solution is 48.8% alum, then by equation 4.11, alum weighs 11.11 lb/gal on a wet basis. It is important to distinguish between dry and wet weight when inquiring about chemical costs.

Table 4.13: The Weight and Cost of Various Chemicals

Chemical	Dry Wgt (lb/gal)	% in Solution	Wet Wgt (lb/gal)	Cost (\$/dry lb)
Alum	5.4	48.8	11.1	0.10
FeCl ₃	14.0	29	48.3	0.10
Anionic Polymer ¹	8.3	0.75	111	1.90
Cationic Poly ¹	8.3	14	59.6	1.58

1) Anionic polymer is Delta's 2540 VHL and the cationic polymer is Delta's 4701

$$D_{Al} = W_{Al} \cdot P \quad (4.10)$$

where: D_{Al} = dry weight of alum (lb/gal)
 W_{Al} = wet weight of alum (lb/gal)
 P = percent of alum in solution (48.8% = .488)

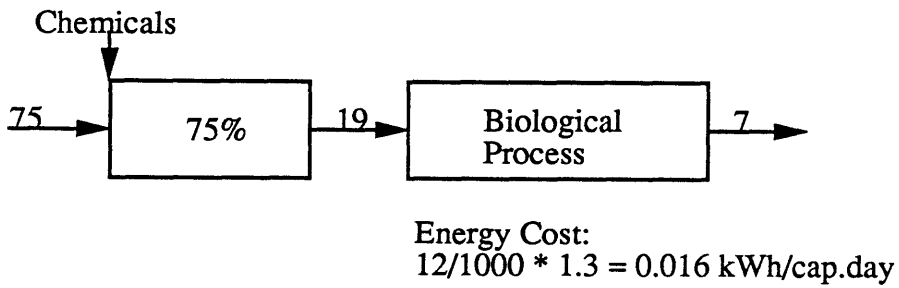
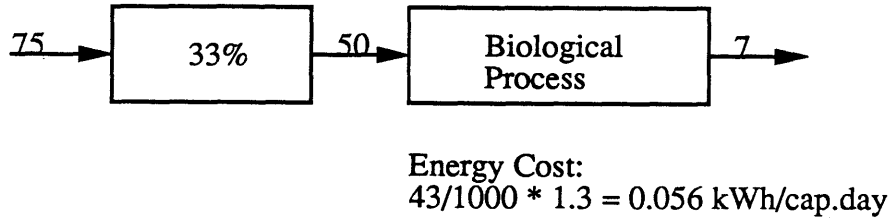

Figure 4.8: Energy Consumption Required for Biological Treatment in Terms of BOD Loading

In order to determine the cost involved in treating a particular wastewater, equation 4.11 can be used.

$$T_c = C \cdot K \cdot \text{Cost} \quad (4.11)$$

where: T_c = treatment cost (\$/Mgal treated)
 C = concentration of alum required to treat the wastewater (mg/l)
 K = unit conversion constant (8.35 (l · lb) / (Mgal · mg))
 Cost = cost of alum on a dry weight basis (\$/lb)

An example using equation 4.11 to determine the treatment cost for a particular wastewater is given assuming the cost of alum is \$0.10 per pound on a dry basis and the required concentration to treat the wastewater is 45 mg/l:

$$T_c = (45 \text{ mg/l}) \cdot (8.35) \cdot (\$0.10/\text{lb})$$

$$T_c = \$33.82 / \text{Mgal}$$

Similar calculations can be carried out for all of the chemicals added to the wastewater to determine a final cost. The costs of chemicals are considered O&M costs.

In order to determine the amount of chemicals needed to treat the wastewater given a specific concentration of chemicals, use equation 4.12. Seasonal flow variation (under stocking) and shelf life (over stocking) of the chemicals must be considered in ordering chemicals.

$$\text{Amount} = Q \cdot C \cdot K \cdot C_{Al}^{-1} \quad (4.12)$$

where: Amount = quantity of chemicals to be ordered (gal/day)
 Q = flow rate (mgd)
 C = concentration of alum required to treat the wastewater (mg/l)
 K = unit conversion constant (8.35 (l · lb) / (Mgal · mg))
 C_{Al} = dry weight of alum (lb/gal)

4.7.2 Capital Costs

Capital costs include the construction and equipment needed for the plant. The capital costs associated with advanced primary treatment are minimal and include chemical feed equipment and scum equipment. The scum equipment is needed to accommodate increased quantities of fats, oils, and greases. Figure 4.9 shows the capital costs associated with various treatment processes based on a flow of 480 mgd and a TSS and BOD influent concentration of 150 mg/l. As shown, there is an increase in cost of approximately 100% for biological treatment over advanced primary treatment. The capital costs associated with a chemical secondary treatment plant are minimal and include chemical feed equipment, scum equipment, flocculation basins, and mixing devices. In this figure, it is assumed that flocculation basins and mixing devices would cost \$13 million for 480 mgd.

4.7.3 Cost of Processing Sludge

The O&M and capital costs associated with the processing of sludge are directly proportional to the amount of sludge generated during a treatment process (Mueller and Anderson, 1983). Therefore, based on Figure 1.3, it would cost nearly twice as much to process sludge generated by chemical secondary or biological secondary as it would cost to process sludge generated by conventional primary treatment alone. It should be noted that work is being done to reduce the amount of metal salts added to the waste stream by replacing a large portion of the metal salt with a small amount of highly charged cationic polymer at a ratio of 7.5:1 (Odegaard, 1990); hence, reducing the amount of sludge generated by the chemical treatment process. The cost of processing sludge generated by the advanced primary treatment process is only about 45% higher than conventional primary treatment.

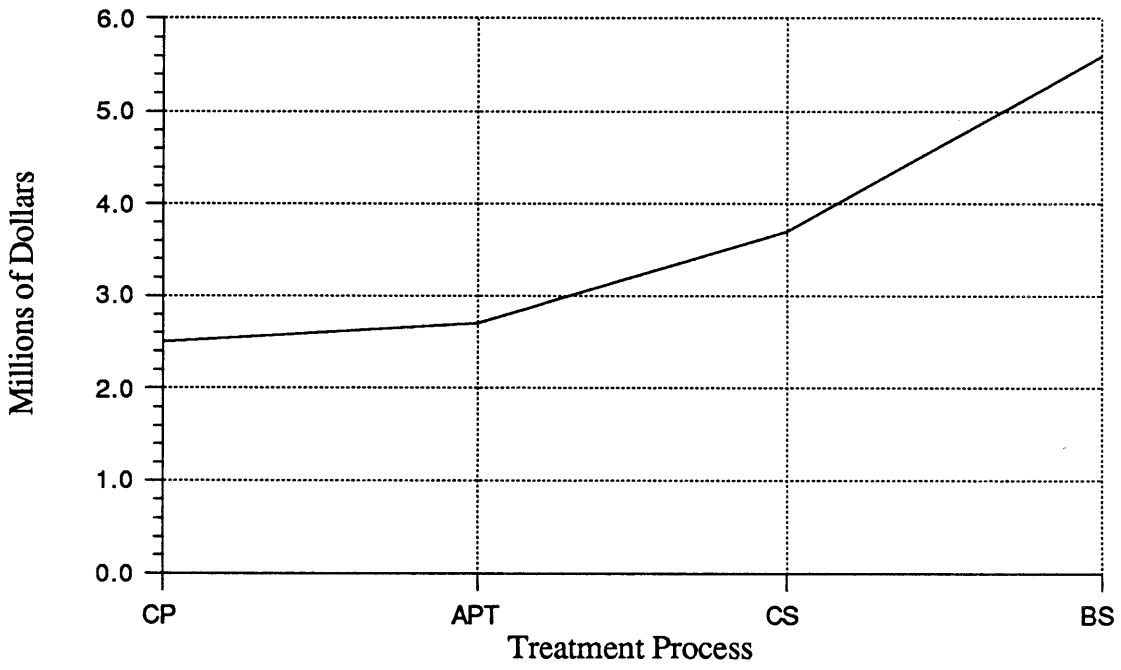

Figure 4.9: Capital Costs Associated With Various Treatment Processes

4.8 Concluding Remarks

Chemically-enhanced wastewater treatment has been shown to improve TSS, BOD₅, P, and FOG removal rates. This is accomplished through physical and chemical means. Since this process includes coagulation and flocculation, the distribution of particle sizes will be altered causing an increase in the biochemical oxidation rate and a decrease in the BOD, TSS, P, and FOG loading from the primary settling tanks. When considering additional treatment processes to follow chemical treatment, it is important to take into account the reduced particle size because the microorganisms used in a biological process can more readily oxidize the organic matter associated with smaller particles. In particular, particles smaller than 1 μm have a two to four fold increase in the oxidation rate over particles $>40 \mu\text{m}$. Since the microorganisms can oxidize the organic matter more readily, the size of any additional treatment facility can be reduced.

Chemical addition can accommodate the increase in flow and loading within a small area eliminating the need for large capital investment caused by constructing new clarifiers. Previously, to obtain 60% TSS and 35% BOD₅ removal rates, an overflow rate of approximately 800 gpd/ft^2 was needed. When chemicals are properly added, overflow rates of 2500 gpd/ft^2 can be maintained while achieving removal rates higher than 60% TSS and 35% BOD₅. Higher removal rates can be obtained in an existing facility reducing or eliminating the need for a biological process.

Most of the design equations for biological treatment are empirical in nature and based on effluent from conventional primary treatment. Therefore, the equations used may not be entirely appropriate for dilute influent; however, they have illustrated that chemically-treated effluent can dramatically reduce the size requirements of any additional biological treatment to the wastewater.

Activated sludge has been the technology of choice recently by many consulting companies due to the large area requirements for fixed media filters. However, by comparing the volume requirements of the trickling filter to that of the activated sludge aeration basins, it has been shown that at low BOD loadings the trickling filter requires less space than the activated sludge system. Also, trickling filters are much easier to operate than activated sludge systems.

Countries such as Sweden and Norway have used large concentrations of metal salts (~150 mg/l) and small concentrations of polymers (< 1 mg/l) to treat their wastewater. It is important to realize that they use high concentrations of metal salts for phosphorus removal and high TSS and BOD removals are an added benefit.

During chemically-enhanced wastewater treatment, large quantities of organic matter is removed before it is oxidized. This organic matter is beneficial in that it is available as methane gas during digestion and can be used as energy to power the treatment plant.

There are a number of research questions to be answered. A few of these questions are as follows:

- Can seawater be used as a coagulant reducing the costs of chemicals?
- Can we obtain high BOD removals at low coagulant concentrations?
- What affect does alkalinity have on low metal salt concentrations?
- Can metal salts be replaced by polymers as coagulants and how will this affect sludge properties?
- What biological process is most appropriate as a follow-up to chemically-enhanced wastewater treatment?
- How can we best reproduce the actual plant performance at the bench scale using low concentrations of chemicals?

REFERENCES

- Amirtharajah, A. and S.L. Trusler, "Destabilization of Particles by Turbulent Rapid Mixing," ASCE Journal of Env. Eng. Vol. 112, No. 6, December 1986.
- ASCE, "Activated Sludge: A Comparison of Oxygen and Air Systems," A Report of ASCE Task Committee on Pure Oxygen Activated Sludge of the Committee on Water Pollution Management of the Environmental Engineering Division of the American Society of Civil Engineers, ASCE, 1983.
- AWWA Committee Report, "State of the Art of Coagulation: Mechanisms and Stoichiometry," Journal of AWWA, pp. 99-108, February 1971.
- AWWA Committee Report: "Coagulation as an Integrated Water Treatment Process," Journal of AWWA, Vol 81, pp. 72-78, October 1989.
- Baker, J.M. and Q.B. Graves, "Recent Approaches for Trickling Filter Design," Journal of the Sanitary Engineering Division, ASCE, 94 SA1, Vol. 65, 1968.
- Black, A.P., "Basic Mechanisms of Coagulation," Journal of AWWA, Vol. 52, pp. 492-501, April 1960.
- Burns, J., City of Sarnia Ontario Treatment Plant, Personal Communications, March 1990.
- Camp Dresser and McKee, SESD's Phase I Facility Plan for Wastewater Treatment and Disposal, November 1986.
- Capestany, G.J., Parametrix, Inc., Personal Communications, March 1990.
- County Sanitation District of Orange County California, 1988 Annual Report. Engineering and Operations. Volume 1 of 3. January 1989.
- Culp, G.L., "Chemical Treatment of Raw Sewage," Water and Waste Engineering, Vol 4, No 7 & 10, pp. 61-63 & 54-57, 1967.

Culp, R.L., G.M. Wesner, and G.L. Culp. Handbook of Advanced Wastewater Engineering, 1978. Van Nostrand Reinhold Company.

Fettig, J., H. Ratnaweera, and H. Odegaard, "Synthetic Organic Polymers as Primary Coagulants in Wastewater Treatment," Water Supply, Vol. 8, Jonkoping, pp 19-26, 1990.

Hanson, B., Count Sanitation District of Los Angeles JWPCP, Personal Communications, March 1990.

Hansson, B., "Chemical Sludge as Soil Conditioner and Fertilizer," Chemical Water and Wastewater Treatment, Schr.-Reihe Verein WaBoLu 62(1985), G. Fisher Verlag, Stuttgart / New York.

Harleman, D.R.F. and S.P. Morrissey, "Chemically-Enhanced Treatment: An Alternative to Biological Secondary Treatment for Ocean Outfalls," ASCE Hydraulics Division Proceedings, July 1990.

Hienke, G.W., A.J-H. Tay, and M.A. Qazi, "Effects of Chemical Addition on the Performance of Settling Tanks," Journal of WPCF. Vol. 52, No. 12, pp. 2946-2954, 1983.

Jorgensen, S.E., Industrial Waste Water Management, 2nd edition, 1979, Elsevier Scientific Publishing Company.

Karlsson, I., "Chemical Precipitation: Alternative or Complement to Biological Treatment," Chemical Water and Wastewater Treatment, Schr.-Reihe Verein WaBoLu 62 (1985), G. Fisher Verlag, Stuttgart / New York.

Karlsson, I., "Pre-precipitation for Improvement of Nitrogen Removal in Biological Wastewater Treatment." Pretreatment in Chemical Water and Wastewater Treatment, H.H. Hahn and R. Klute, eds, Springer-Verlag Berlin Heidelberg, pp. 251-261, 1988.

Kemira Water Treatment Inc., Sewage Treatment the Scandinavian Way, Kemira Kemi AB, Helsingberg, Sweden, 1989.

Klass, C.P., A.J. Sharpe, and J.M. Urick, "Polyelectrolyte Retention Aids," Monograph of the Technical Association of the Pulp and Paper Industry, Retention of Fine Solids During Paper Manufacture, 1975, TAPPI Press, Atlanta.

Konopka, W.F., Point Loma Ocean Outfall Annual Monitoring Report 1988, City of San Diego Water Utilities Department Metro Wastewater Division, 1989.

Konopka, W.F., City of San Diego's Point Loma Treatment Plant, Personal Communications, March 1990.

Langworthy, A., City of San Diego's Point Loma Treatment Plant, Personal Communications, March 1990.

Levin, A.D., G. Tchobanoglous, and T. Asano, "Characterization of the Size Distribution of Contaminants in Wastewater: Treatment and Reuse Implications," Journal of WPCF, Vol 57, No 7, pp. 805-816, 1985.

Metcalf & Eddy. Wastewater Engineering: Treatment, Disposal, Reuse 2nd Edition, 1979. McGraw-Hill Inc.

Morrissey, S.P. and D.R.F. Harleman, Technology and Policy Issues Involved in the Boston Harbor Cleanup, Massachusetts Institute of Technology, R.M. Parsons Laboratory Technical Report No. 327, November 1989.

Morrissey, S.P. and D.R.F. Harleman, A Performance Analysis of the South Essex Sewerage District (SESD) Primary Treatment Plant, Massachusetts Institute of Technology, R.M. Parsons Laboratory Technical Note No. 28, February 1990.

Morrissey, S.P. and D.R.F. Harleman, Data and Analysis of Chemical Addition Test #3 at South Essex Sewerage District (SESD) January 22-26, 1990, Massachusetts Institute of Technology, R.M. Parsons Laboratory Technical Note No. 29, March 1990.

Morrissey, S.P. and D.R.F. Harleman, Data and Analysis of Chemical Addition Test #4 at South Essex Sewerage District (SESD) March 25 - April 16, 1990, Massachusetts Institute of Technology, R.M. Parsons Laboratory Technical Note No. 30, May 1990.

Mueller, J.A. and A.R. Anderson, Municipal Sewage Systems, "Ocean Disposal of Municipal Wastewater: Impacts on the Coastal Environment," Edited by E.P. Myers. 1983.

NRC Subcommittee on Sewerage Treatment, Committee on Sanitary Engineering, National Research Council, "Sewage Treatment at Military Institutions," Sewage Works Journal, Vol. 18, p. 787, 1946.

Odegaard, H., "Appropriate Technology for Wastewater Treatment in Coastal Tourist Areas," Water Science Technology. Vol 21, No 1, pp. 1-17, 1988.

Odegaard, H., "Coagulation as the First Step in Wastewater Treatment." Pretreatment in Chemical Water and Wastewater Treatment, H.H. Hahn and R. Klute, eds, Springer-Verlag Berlin Heideburg, pp. 261-271, 1988.

O'Melia, C.R., "Coagulation in Water and Wastewater Treatment," Water Quality Improvement by Physical and Chemical Processes, E.F. Gloyna and W.W. Echenfelder, Jr., eds, 1970, University of Texas Press, Austin and London.

O'Melia, C.R., "Coagulation," Water Treatment Plant Design for the Practicing Engineer, R.L. Sanks, eds, 1978, Ann Arbor Science Publishers, Inc., Ann Arbor, Michigan.

Pamson, G., County Sanitation District of Orange County California, Personal Communications, April 1990.

Parametrix, Inc. Summary Report: North End Wastewater Treatment Plant Physical-Chemical Testing Program. Prepared for the City of Tacoma. Department of Public Works Sewer Utility Division. 1988.

Purenne, P., Montreal Urban Communities Treatment Plant, Personal Communications, June 1990.

Rudolfs, W., L.R. Setter, and W.H. Baumgartner, Sewage Works Journal, Vol. 1, p 398, 1929.

Sagberg, P., Oslo's VEAS Wastewater Treatment Plant, Personal Communication, April 1990.

Shao, Y.J., City of Los Angeles Hyperion Treatment Plant, Personal Communications, March 1990.

Shao, Y.J., J. Crosse, E. Keller, and D. Jenkins, "High Rate Conventional Air Activated Sludge Operation at Hyperion," To be Presented at the 63rd Annual WPCF Conference on October 7, 1990.

Stahl, J., Count Sanitation District of Los Angeles JWPCP, Personal Communications, March 1990.

Stumm, W, and J.J, Morgan, "Chemical Aspects of Coagulation," Journal of AWWA, Vol. 54. pp. 971-992, August 1962.

Tighe & Bond, Inc., Draft: Jar Test Report on Enhanced Primary Treatment, South Essex Sewerage District, Salem, Massachusetts, February 1990.

Tighe & Bond, Inc., Report on Full-Scale Test: Advanced Primary Treatment, June 1990.