

TOPICS IN CONDITIONALS

by

SABINE IATRIDOU

D.D.S., Aristotelian University of Thessaloniki
(1982)

M.A., University of Hawaii
(1986)

Submitted to the Department of
Linguistics and Philosophy
in partial fulfillment of the requirements for the degree of

DOCTOR OF PHILOSOPHY

at the

MASSACHUSETTS INSTITUTE OF TECHNOLOGY
September 1991

© Sabine Iatridou

The author hereby grants to M.I.T. permission to reproduce and to distribute copies
of this thesis document in whole or in part.



Signature of author _____

Department of Linguistics and Philosophy
September, 1991

Certified by _____

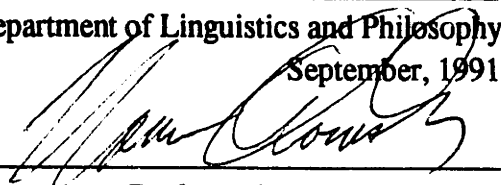

Professor Noam A. Chomsky
Thesis Supervisor

Accepted by _____

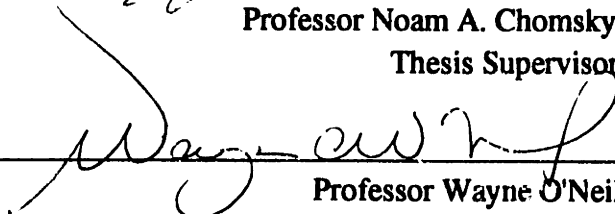

Professor Wayne O'Neil
Chairman, Departmental Committee

MASSACHUSETTS INSTITUTE
OF TECHNOLOGY

NOV 20 1991

LIBRARIES

ARCHIVES

ABSTRACT

This thesis is concerned with a number of issues that pertain to the syntax and semantics of conditional constructions.

In Chapter 1, there is a treatment of basic syntactic properties that characterize the relationship between the IF-clause and the matrix clause, as well as relationships internal to the IF-clause. Some similarities between if and other elements that introduce clauses are discussed.

In Chapter 2, there is a typology of conditional constructions with respect to their meaning and syntactic properties. It is argued that there are three different types of conditionals, if the semantic and syntactic relationship between the IF-clause and the matrix clause is taken into account. The contrasts between two conditional types is assimilated to the contrasts between appositive and restrictive relative clauses, and between BECAUSE- AND SINCE-clauses.

In Chapter 3, it is argued that conditional then has a meaning, and a specific proposal is advanced to account for its distribution on semantic grounds.

In Chapter 4, there is a discussion of the syntactic properties of conditional then, and a general proposal is put forth to account for the syntactic environments in which its presence is restricted.

ACKNOWLEDGMENTS

For their help and support with my thesis I would like to thank my committee: Noam Chomsky, Irene Heim, Howard Lasnik and David Pesetsky.

I don't know where to begin thanking Noam Chomsky. One of the best things that ever happened to me and definitely the biggest honour, is having been given the opportunity to learn from him. It does not happen to many people to have a legend whose office is across the hall; especially one who is as human as he is legendary. I enjoyed and benefitted from every single conversation that I had with him over the years and I am very happy to say that I had many. There is no place in the text where I thank him for any specific suggestion; the intellectual debt is too large to acknowledge in the particulars.

I started meeting regularly with Irene Heim only in my fourth year but my admiration for her sincerity and style came very quickly. Everyone who knows Irene and who knows that she never does or says anything she does not mean will understand why I came to appreciate her letting me stay in her office for many long afternoon hours as a form of acceptance, even a form of compliment. I want to thank her for everything she taught me and for putting up with my ignorance in semantics so patiently. Our relationship started out as one between a semantics professor and a student. I would like to think it has ended up as friendship.

For syntax students at MIT, Thursdays are marked for two things. One is that that is the day of the week you can meet with Howard Lasnik. It is widely believed that for any idea that others will dismiss as gibberish, baloney or as violating the most basic principles of rational inquiry, from Howard you will at most get a "That's very interesting, but ...". He always tries to find the good points in any proposal and for this reason many new ideas are initially presented to him. For this attitude I would like to thank him as well as for many truly fruitful and stimulating discussions.

I would like to thank David Pesetsky for many ideas in this thesis and in other work that I did over the years. David is very generous with ideas and puts a lot of energy in improving his students' work, both with respect to content as well as with respect to style of argumentation. I have learned a lot about syntactic theory from him. Moreover, he is charismatic and very entertaining as a teacher. I know for a fact that if you take his classes you can't help but learn syntax; I have seen it happen to the (at first) most ardently disinterested.

Ken Hale was not a member of my dissertation committee, but he might just as well have been for all his influence on me. I don't think he realizes to what extent he functions as a role model for his students. I believe it's safe to say that he is in the heart of every single person who has ever met him. His insights about language and his knowledge of languages are, of course, legendary. I know of quite a few ideas that many people think of as recent developments in the theory, yet Ken has proposed them years before in unpublished papers. Also, he is probably the only person in the world to mix up Miskitu and Basque. I would like to thank him for being there, for the many things I have learned from him and for having given me the opportunity to stand in front of a class by his side.

I want to thank Jim Higginbotham, Alec Marantz and Bob Stalnaker for their help, ideas, and discussions with me. Also, I would like to go on record as having explained the ECP to the latter.

I have spent four wonderful years at the MIT Linguistics Department and there are many people responsible for this. First of all the faculty members whose classes I attended: Noam Chomsky, Ken Hale, Morris Halle, Irene Heim, Jim Higginbotham, Richard Kayne, Richard Larson, Wayne O'Neil, David Pesetsky and Donca Steriade. A special salute to Morris Halle for having shaped the atmosphere in the department the way he did.

The department is set up in such a way that the quality of everyday life, especially in the first two years, depends almost entirely on the quality of the peer-group one is in. This is solely a matter of luck and I was particularly fortunate to have been a classmate of Eulàlia Bonet, Lisa Cheng, Hamida Demirdash, Michael Hegarty, Mika Hoffman, Peter Ihionu, Utpal Lahiri, Paul Law and Chris Tancredi. I was also given many chances to enjoy the company of Phil Branigan, Chris Collins, Viviane Deprez, Bill Idsardi, Doug Jones, Mark Kantor, Itziar Laka, Harry Leder, Anoop Mahajan, Rolf Noyer and Hiroaki Tada. Many thanks to all of you!

The presence of many visitors enriches the intellectual and social life of the department. But for me a few stood out: Elena Benedicto, Albert Branchadel, Robert Davis, Jaklin Kornfilt, Pierre Pica and Nick Sobin.

I would also like to acknowledge (and admit to liking) the following people, not all linguists, but all of whom I met because of my connection to the linguistic community: Robin Belvin, Hans den Besten, Olga Brown, Andrea Calabrese, Brian Joseph, Mark Kampana, Danae Kondaxis, Sylvia Kowenberg, Ben Pesetsky, Eleni Philippaki-Warburton, Luigi Rizzi, Joanna Rosseliò, Jean Rutten, Mauro Scoretti, Norval Smith, Tim Stowell, Esther Torrego, Gert Webelhuth, Ken Wexler and Deirdre Wilson.

There are a few personal debts that I would like to express. First of all, to the person who brought me to Linguistics. This is Derek Bickerton. I am grateful to him for many reasons but two need special mention. The first one is that he introduced me to ways and values of being idiosyncratic and non-conformist in linguistics before introducing me to received wisdom. I hope this attitude will stay with me. The second reason is Yvonne Bickerton, whose kindness, understanding and sheer presence spread such a protective cloud that living in Hawaii did not feel like living in the middle of an ocean.

During my stay at MIT, there were three people that I took the greatest pleasure in knowing and loving. These are Eulàlia Bonet, Michael Hegarty and Chris Tancredi. I don't know what I have done to deserve friends like you. I cannot (nor want to) imagine how my life in Cambridge would have been without Eulàlia. Thanks for being so terrific to laugh with, to cry with, to be woken up by, to be bossed around by, to be pampered by, to be sent off to job-talks by, to in vain explain pragmatics to, or simply put, to be with. Michael, I'll keep it simple, since I know you prefer few words. Thanks for letting me come so close; I know it was a rare privilege and I will always try to honour it. Chris, my personal judgment machine, thanks for filling the house with noises which I struggled to comprehend but always enjoyed, for being so witty and brilliant, for making me appear less lazy and for a small piece of chocolate you once brought home.

My family, nuclear and extended, has always been infinitely supportive, understanding, stimulating and loving. I always knew that Cambridge was across the river from Amsterdam and on the other side of Olympus from Thessaloniki.

Finally, I would like to thank Kostas Marinos for having been born at the right time and place so that I could meet him. And since I have the opportunity, I would like to thank him for the years to come.

This thesis is dedicated to my grandmother Elpi Kokkini.

Η θέση αυτή αφιερώνεται στην γιαγιά μου Ελπη Κοκκινη.

TABLE OF CONTENTS

ABSTRACT	2
ACKNOWLEDGMENTS	3
DEDICATION	5
CONTENTS	6
PROLEGOMENON	7
The Piranha Brothers	8
CHAPTER ONE: SOME INITIAL SYNTACTIC PROPOSALS	9
1.1 Positioning	9
1.2 Containment in the VP or I-bar adjunction?	15
1.3 How does the IF-clause appear sentence-initially?	24
1.4 Inside the IF-clause	33
1.4.1 What and where is <i>if</i> ?	34
1.4.2 Does <i>if</i> have lower construals?	41
CHAPTER TWO: TYPES OF CONDITIONALS	50
2.1 The Relevance Conditional or Conditional Speech Act	50
2.2 The Factual Conditional	58
2.2.1 A first description	58
2.2.2 FC vs. RC	63
2.2.3 FC vs. HC	69
2.2.4 BECAUSE- and SINCE-clauses	81
2.2.5 Back to the FCs	91
2.2.6 Summary	96
CHAPTER THREE: THE SEMANTIC CONTRIBUTION OF 'THEN'	99
3.1 The semantic contribution of <u>then</u>	99
3.1.2 Where <u>then</u> does not appear	103
3.1.3 Resumptive Pronoun?	117
3.1.4 A modification of (2b)	121
3.2 Some more environments where <u>then</u> is degraded	123
3.3 Two side-points	131
3.3.1 'Only/even CP' needs Case	131
3.3.2 <u>pro</u> cannot refer to events	138
CHAPTER FOUR: THE SYNTAX OF "THEN"	146
4.1 The syntax	146
4.1.1 What follows <u>then</u>	146
4.1.2 Positioning	147
4.1.3 Head or Specifier	156
4.2 Some more environments where <u>then</u> cannot appear	166
4.2.1 Negative Contexts	166
4.2.2 Embedded Contexts	171
4.2.3 Towards a solution	175

PROLEGOMENON

Very recently, somebody told me that most people see their dissertations as their only chance for a claim to fame and rightly so. If this is correct, then I have missed my chance, because I see my thesis as an exercise in some issues I didn't have the opportunity to explore until my final year as a graduate student.

When time came to choose a dissertation topic, I decided I wanted to try something relatively new, without much linguistic literature so that I could find fresh data to work on. Conditionals seemed ideal for this purpose: there is 2000 years of philosophical literature on them, a fair amount of semantic work, and very little syntax. But choosing such a topic for a thesis has very specific dangers and I was made aware of them. First of all, it wasn't obvious that there were any linguistic issues over and above those of interpretation and I obviously wasn't going to write a philosophical or purely semantic thesis. Second, it was probably too late to start looking at new data, as well as at a semantics literature I had never seen before. As a result of either, I could find myself in the middle of the spring semester without a topic. Finally, linguistic issues come in waves, like fashions, and I might be producing something that would be so much out of sync with current interests that it would never be taken of the shelf, if it even were to get up there in the first place. However, it seemed to me that if I didn't dare attempt something like this at the MIT Linguistics Department, where there is a wonderful collection of syntacticians and semanticists, as well as the world's leading philosopher on conditionals, I would never dare it anywhere. So thanks to a combination of my own stubbornness and the Department's *laissez faire* spirit, I went ahead.

In the course of writing, I met with some of the predicted difficulties but at least I didn't find myself without a topic in the middle of the spring semester. Probably, I would have written a better thesis if I had chosen a topic that I had been familiar with at the time I started to write. Definitely, I would have written a longer one, as I would have had to spend less time on background literature.

Towards the end of June, Noam Chomsky, having forgotten who the ones were that had the original reservations, asked me if I was finally convinced that conditionals weren't a dead topic. I couldn't have hoped for, nor imagined a happier ending.

The Piranha Brothers

"...Denied the opportunity to use their talents in the service of their country, [the Piranha brothers] began to operate what they called 'The Operation'. They would select a victim and then threaten to beat him up if he paid the so-called protection money. Four months later they started another operation which they called 'The Other Operation'. In this racket they selected another victim and threatened *not* to beat him up if he *didn't* pay them. One month later they hit upon 'The Other Other Operation'. In this the victim was threatened that if he didn't pay them they would beat him up. This for the Piranha brothers was the turning point."

[excerpt, *Monty Python's Flying Circus*, Pantheon, 1989]

Chapter 1

SOME INITIAL SYNTACTIC PROPOSALS

0. *The Topic*

This thesis is an exploration of linguistic issues related to conditional constructions. For a variety of reasons I have limited the discussion to primarily one language (English) and ignored what is referred to as the subjunctive or counterfactual conditional. Needless to say, research in either of those directions is crucial, but this thesis will have to content itself with many other character flaws anyway.

1.1 *Positioning*

The first problem I will be addressing is that of the position of the IF-clause. Linearly, the IF-clause can be in a sentence-initial (1a) or sentence-final position (1b):

- (1) a. If it rains, Peter takes the dog out
- b. Peter takes the dog out if it rains

It is possible to check the hierarchical positioning of the IF-clause with respect to the main clause with tests that rely on constructions that have

been argued to be sensitive to c-command¹ relationships. Application of these tests will show that the IF-clause can be c-commanded by a main clause constituent only if it is in a sentence-final position. In such a case, the subject, but not the object of the main clause, c-commands the IF-clause.

One such test is based on Binding Condition C (Chomsky (1981) and others). In the following permutations, if the R-expression Mary is c-commanded by a co-indexed antecedent, the sentence will be ungrammatical:

(2) a. *She₁ yells at Bill if Mary₁ is hungry

b. If Mary₁ is hungry, she₁ yells at Bill

(3) a. Mary₁ yells at Bill if she₁ is hungry

b. If she₁ is hungry, Mary₁ yells at Bill

(4) a. Bill visits her₁ if Mary₁ is sick

b. If Mary₁ is sick, Bill visits her₁

(5) a. Bill visits Mary₁ if she₁ is sick

b. If she₁ is sick, Bill visits Mary₁

¹ There have been several different definitions of c-command over the years. I will be using the following:

- (i) a c-commands b iff a does not dominate b and the first branching node dominating a, also dominates b.

(i) is more or less the definition of c-command in Reinhart (1976) and following her, Chomsky (1986).

(6) She₁ yells at Bill if she₁ is hungry

Sentence (2a) is ungrammatical because Mary is c-commanded by she, violating Binding Condition C. If instead of the R-expression there is a pronoun, as in (6), the sentence is fully grammatical. That of all the possible combinations only (2a) violates Binding Condition C indicates that it represents the only configuration in which the IF-clause is c-commanded by a matrix clause constituent.

If the above discussion is correct, when the IF-clause is sentence-final it may stand somewhere between the [SPEC,IP] position and the object contained in the VP. This gives us two possibilities as attachment sites: the VP (contained in it or adjoined to it) and the I-bar². It has been argued that VP-preposing tests can distinguish between those two possibilities. The idea is that if the IF-clause can prepose with the sentence fragment (the VP), it is contained in (or adjoined to) it. If it cannot, it is adjoined to the I-bar or higher. Application of such VP-preposing tests shows that the IF-clause may be contained in (or adjoined to) the VP³:

² By "I-bar" I will be referring to the area between the [SPEC,IP] subject and the VP. Pollock (1989) and many others following him have argued that this area consists of functional heads which project their own maximal projection. How many such functional categories there are, as well as their relative order differs from author to author. I will be following Pollock only in representing negation as a separate head and maximal projection; I have argued elsewhere (Iatridou (1990)) that the arguments for the other maximal projection he proposed (AgrP) should be reconsidered.

³ The judgments of sentences containing VP-preposing are relative: it should be taken into account that VP-preposing, as such, yields marked sentences.

- (7) a. Take the dog out if it rains though Peter may, he is still
afraid of water
- b. Take the dog out though Peter may if it rains, he is still
afraid of water
- (8) I told Peter to take the dog out if it rains
- a. ...and take the dog out if it rains, he will
- b. ...and take the dog out he will if it rains

The full acceptability of (7a) and (8a) shows that the IF-clause may be inside the VP or adjoined to it. The acceptability of (7b) and (8b) can be attributed to either the preposing of only a part of the VP, leaving one segment behind (in the case of adjunction), or to the additional option of using I-bar as an adjunction site⁴. It is, in fact, possible that the latter is a

⁴ According to David Pesetsky (p.c.) there is a third possible source of the sentence-final IF-clause, as argued by the contrast between (i) and (ii):

- (i) Take the dog out though he₁ may if Peter₁ is energetic, ...
- (ii) *He₁ may take the dog out if Peter₁ is energetic

Pesetsky suggests that in (i), the IF-clause has preposed with the VP and then extraposes. If this is an option, one might wonder why it is not available in (ii) as well, i.e. if the IF-clause in (ii) could extrapose, this sentence would not be a Binding Condition C violation. A possible reply might be a reformulation of the "Right Roof Constraint" (RRC) of Ross (1967), which originally stated that an extraposed constituent cannot leave the clause it was base-generated in. As such this constraint would predict that (ii) is grammatical, since if the IF-clause adjoined to the IP, it would not violate the RRC, and the IF-clause would not be c-commanded by the matrix subject anymore. So if the RRC is to preclude (ii), it should be restated, either taking into account intermediate functional categories as the "roof", or by considering adjunction as crossing the roof. The latter option is not implausible, as long as containment is defined as domination by all segments of a projection. In such a case, adjunction of the IF-clause to the IP would result in the latter not containing the former anymore.

Returning to (i) and (ii), according to some native speakers the status of (i) is not different from that of (ii) as long as the IF-clause is read parenthetically. If its is not read like that, both (i) and (ii) are unacceptable. Moreover, for Pesetsky's observation to hold, the IF-clause should not be c-commanded by the matrix subject. But there are several ways to test that it can be:

real option, sometimes made use of and resulting in a difference in meaning. But for the time being, I will concentrate on the (a) sentences which are supposed to indicate containment in or adjunction to the VP.

When the IF-clause is sentence-initial, it can adjoin to the IP or the CP. That the latter is an option can be seen from the sentences in (9):

- (9) a. If it rains, what shall we do?
b. If it rains, are we going to leave?
c. If John comes, wake me up
d. If he's right, what a fool I've been!

Of course the sentences in (9) show that an IF-clause can adjoin to the CP node only to the extent that the arguments that have been used to show that questions, imperatives and exclamatives involve (movement to) a CP node are correct.

The structures of (1a) and (1b), then, are roughly as in (9a) and (9b) respectively⁵:

-
- (iii) Finish school though every boy₁ will if he₁ wants to get a job, ...
(iv) Report it in the paper though they₁ will, if each other's₁ pictures are on sale, ...

Both (iii) and (iv) are acceptable sentences, showing that every boy and they c-command he and each other respectively. And even if the c-command relationship in (iii) can be said to obtain at LF after raising of the QP every boy, the same cannot be said for (iv) (unless reconstruction is required in (iv) but blocked in (i)).

Summarizing then, if the judgments of (i) and (ii) are indeed as marked, they would show that Pesetsky's suggestion for extraposition after VP preposing is possible. But the sentences in (iii) and (iv) show that it is not the only possible account of a clause-final IF-clause.

⁵ In (10a) I represent the sentence-initial IF-clause as adjoined to the IP. In a later chapter I will argue that there is another possibility as well, namely adjunction to the CP. I will also return later to the question of whether (10a) and (10b) are derivationally related.

(10) a.

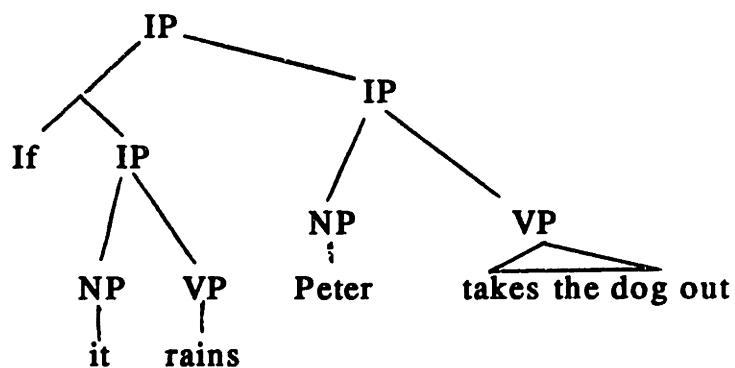

b.

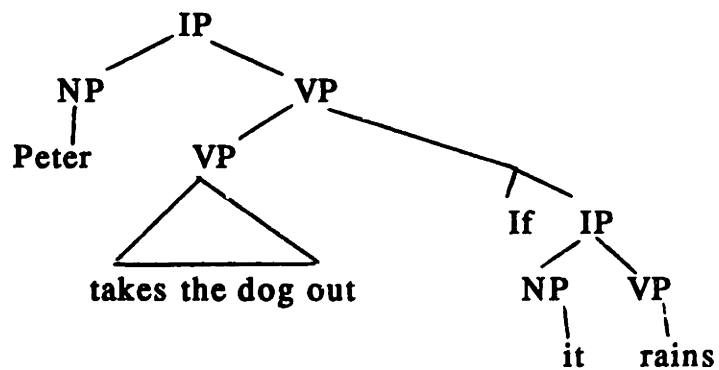

As already mentioned, the only configuration in which a matrix constituent c-commands the IF-clause is, where the subject Peter c-commands (inside) the IF-clause.

1.2 *Containment in the VP or I-bar adjunction?*

In the previous section we saw that the IF-clause can, but does not have to, prepose with the VP. In this section we will take a closer look at this optionality.

Adverbial clauses interact scopally with sentence negation when they are sentence-final. The most widely discussed case is that of BECAUSE-clauses: sentence (11) is ambiguous and can be continued by either (12a) or (12b):

(11) Peter doesn't hit his dog because he loves her

- (12) a. ...he hits her for an entirely different reason
b. ...in fact, he never even threatens to hit her

When the adverbial clause is sentence-initial as in (13), only one reading is possible, namely the one that can be continued by (12b):

(13) Because he loves her Peter does not hit his dog

We can observe the same phenomenon with IF-clauses: sentence-finally they yield ambiguities, sentence-initially they do not:

(14) **Mary doesn't yell at Bill if she's hungry**

(15) a. **...but if she's sleepy**

b. **...since hunger keeps her quiet**

(16) **If she's hungry Mary doesn't yell at Bill**

The obvious question is what is responsible for the ambiguity of (11) and (14). One possible answer is that it is due to scopal interaction at LF; one such LF account could argue that the adverbial clause and negation are in some sense "close enough" to scopally interact; that is, the BECAUSE-clause might raise at LF and take scope over negation, or vice versa. Another way to get the ambiguity in question, but still at LF, is via something like the Scope Principle of May (1985) which permits one LF representation to yield two readings, as long as the two scopal elements govern each other at LF; in other words, if the BECAUSE-clause and negation govern each other, this proposal predicts that either can have scope over the other. Another possibility is that the two readings reflect different S-structure attachment sites, with the adverbial clause being attached below sentential negation in the readings of (12a) and (15a), and above sentential negation in the readings of (12b) and (15b).

If we combine the present constructions with the VP-preposing tests, we will see that the account that appeals to different S-structure adjunction sites is advantageous. Consider the following sentences:

(17) a. **Hit his dog because he loves her though he hasn't, ...**

b. **Hit his dog though he hasn't because he loves her, ...**

Both (17a) and (17b) are unambiguous, but with different meanings. Sentence (17a) is interpreted along the lines of "it's not the case that he hits her because he loves her" (i.e. sentential negation over the adverbial clause); on the other hand, (17b) has only the meaning of "he doesn't hit her and the reason he doesn't is that he loves her" (i.e. adverbial over negation). It seems, then, that a sentence like (17b) corresponds to two S-structures:

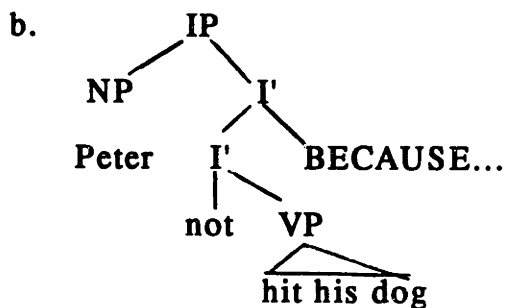
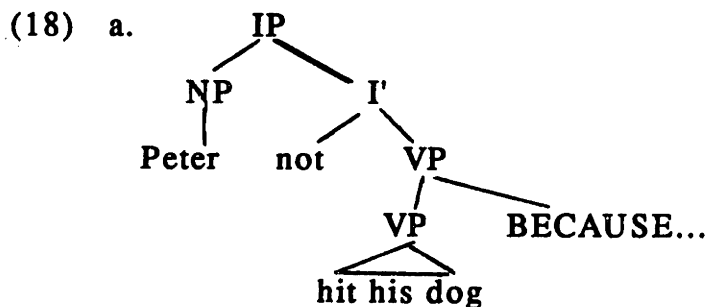

When VP-preposing is applied to (18a) it yields sentence (17a) and when it is applied to (18b) it yields (17b).

There is one more way to show the correctness of the structures in (18). Negative Polarity Items are licensed only in the scope of certain triggers, negation being one such element. Looking at (18), we see that the BECAUSE-clause is in the scope (i.e. c-command domain) of negation in (18a) but not in (18b). The prediction, then, is that if the BECAUSE-clause

contains an NPI, the sentence will have the S-structure of (18a) and be interpreted along the lines of (12a).

If the matrix predicate contains an NPI, it might seem that either one of the two structures in (18) will suffice, since the VP is inside the scope of negation in both cases. However, Linebarger (1980) has argued that an NPI is licensed only in the immediate scope of negation. The matrix predicate is in the scope of negation in both (18a) and (18b), but it is in the immediate scope of negation only in (18b). Since only one constituent can be in the immediate scope of negation, only that constituent will be able to contain an NPI. This means that if the matrix predicate contains an NPI, the relevant structure must be (18b). This of course also means that we cannot have one NPI in the matrix clause and one in the BECAUSE-clause:

(19) *His paper didn't hold a candle to Mary's because he had any help

We have seen, then, that an NPI can occur in the BECAUSE-clause only when the matrix verb is understood as not being inside the immediate scope of negation and that an NPI can occur in the matrix clause only if the BECAUSE-clause is understood as not being in the immediate scope of negation. This has the following result: a sentence like (11) is ambiguous between (12a) and (12b), but if such a sentence contains an NPI in the matrix clause, it will be unambiguously interpreted as (12b). On the other hand, if the BECAUSE-clause contained an NPI, it will again be unambiguous but only along the lines of (12a). Consider, for example the sentences in (20) and (21):

(20) John doesn't give a damn because he is sick

(21) I didn't buy the ticket because I had a hope in hell of winning

Sentence (20) is unambiguously interpreted as meaning that John doesn't give a damn, and the reason is that he is sick. Sentence (21) is likewise unambiguously interpreted as meaning that I bought the tickets but not because I had a hope in hell of winning. The lack of ambiguity (along (12a-b) for (11)) of these sentences is exactly what Linebarger predicts.

Sentence (20) has an NPI in the matrix sentence and therefore negation must have the matrix predicate in its immediate scope and not the BECAUSE-clause. Sentence (21) has an NPI in the BECAUSE-clause and therefore negation is understood as taking immediate scope over it and not over the matrix predicate.

Let us now return to the VP-preposing test and the discussion of (17a) and (17b), which are repeated below:

(17) a. Hit his dog because he loves her though he hasn't, ...

b. Hit his dog though he hasn't because he loves her, ...

Recall that (16a) corresponds to structure (17a) and is interpreted with negation having scope over the adverbial, while (17b) corresponds to (17b) and is interpreted with the adverbial clause having scope over negation. In more recently discussed terms, this means that in (17a) the BECAUSE-clause is in the immediate scope of negation and in (17b) the matrix predicate is. This, in turn, leads us to predict that an NPI should be

acceptable only in the BECAUSE-clause of (17a), but not in that of (17b).

This prediction is borne out⁶:

(22) Call because he wants anything though he does not, ...

(23) *Call though he does not because he wants anything, ...

(24) Buy the ticket because I had a hope in hell of winning though I did not...

(25) *Buy the ticket though I did not because I had a hope in hell of winning, ...⁷

The discussion so far indicates that although an adverbial clause can either be preposed with the VP or be stranded by it, the two alternatives differ in meaning. But if the BECAUSE-clause had the same attachment site in both (17a) and (17b) one would expect that at least after reconstruction both sentences should be ambiguous, just as the one without VP-preposing is. That reconstruction does, in fact, take place can be seen from the unacceptability of (26), which is due to a Binding Condition C violation:

(26) *Hit John's₁ dog though he₁ thinks that Mary will, ...⁸

⁶ Sentences (22) and (24) are of course stylistically marked. What is relevant is their respective contrasts with (23) and (25).

⁷ Conversely, this account makes the correct prediction that an NPI is acceptable only in the matrix clause of (17b), not of (17a):

- (i) *Have a hope in hell of winning because he is stupid though he does not, ...
- (ii) Have a hope in hell of winning though he does not, because he's stupid, ...

⁸ This additional embedding is necessary to preclude an alternative account of the ungrammaticality of this sentence. Consider a simpler sentence:

To recapitulate the argument so far: one might argue that the ambiguity of a sentence like (27)(=10)

(27) Peter doesn't hit his dog because he loves her

is due to scopal interaction at LF. Looking at sentences like (17a) and (17b), and assuming that reconstruction does take place in them (as indicated by (26)), one would expect both of (17a) and (17b) to be ambiguous. But as we saw, (17a) and (17b) are unambiguous and not synonymous. I would like to propose that in (17a) the BECAUSE-clause is inside (or attached to) the VP, as is witnessed by the fact that it preposes with it. This means that this BECAUSE-clause is unambiguously under sentential negation. On the other hand, in (17b) the BECAUSE-clause is stranded by VP-preposing, suggesting that in this case the BECAUSE-clause is outside the VP. If it had been contained in the VP and stranded by VP-preposing as a VP-segment, it would still have been under sentential negation. But this can't be so since the reading of (17b) is clearly one in which the BECAUSE-clause has scope over negation. In other words, (17a) and (17b) are derived by VP-preposing from two different S-structures. In turn, this means that the ambiguity of (11)/(27) is not the result of scopal

(i) *Hit John's₁ dog though he₁ does, ...

If the VP-internal subject hypothesis is correct, the preposed VP contains a trace of the subject, which illicitly c-commands John:

(ii) [t₁ hit John's₁ dog] though he₁ does, ...

In (26) this issue is avoided because the VP-internal trace is co-indexed with Mary.

interaction at LF but the result of the sentence being (S-)structurally ambiguous between (17a) and (17b) with the associated readings transparently given by S-structure. I will argue that something similar holds for the ambiguity of (14), repeated below:

(14) Mary doesn't yell at Bill if she's hungry

Recall the ambiguity of (14) created by the interaction of the IF-clause with sentential negation. If we combine VP-preposing and interaction with negation as we did above for BECAUSE-clauses, we get:

(28) Smile at Bill if she's hungry though she doesn't, ...

(29) Smile at Bill though she doesn't if she's hungry, ...

(30) Take the dog out if it's raining though he does not, ...

(31) Take the dog out though he does not if it's raining, ...

Sentences (28)/(29) and (30)/(31) are all unambiguous sentences which differ from each other exactly along the lines of (17a)/(17b). In other words, in (28) and (30) the negation has scope over the IF-clause, while in (29) and (31) the IF-clause has scope over the negation. This would strongly suggest that (14) is (S-)structurally ambiguous between (32a) and (32b):

(32) a.

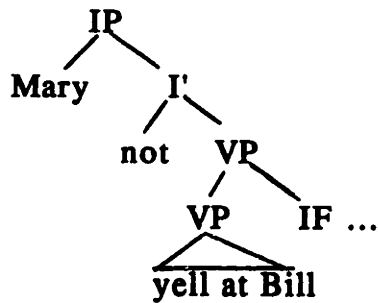

b.

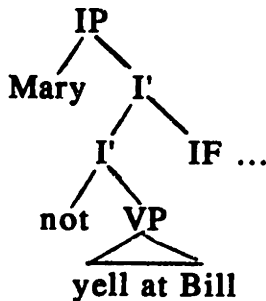

The argument used above for distinguishing between the two structures cannot be directly transferred here, since an IF-clause can itself license an NPI without there being any overt negation in the sentence:

(33) a. If anybody comes, let me know

b. Let me know if anybody comes

One part of the test, however, does transfer over directly: if the matrix predicate contains an NPI, then the structure must be as in (32b), since only there is the VP inside the immediate scope of negation. The prediction is, then, that when the matrix predicate contains an NPI, the IF-clause will be interpreted outside the scope of negation. This prediction is borne out. Contrast the ambiguous (13) with the unambiguous (34), where, as can be seen from the unacceptability of the continuation, negation cannot have scope over the IF-clause:

- (34) He won't have a hope in hell of winning if he arrive on Tuesday,
#but if he arrives on Wednesday

If this whole discussion is correct, it implies that sentences (7) and (8) of the previous section represent a genuine option in attachment sites with a predicted difference in meaning, and NOT an option in "how much" of the VP would prepose with the possibility of stranding the IF-clause within a VP-segment. This implies, in other words, that the lower VP-segment can't extract alone, showing a difference between segments and categories with respect to movement.

Finally, one might wonder why I chose the I-bar as an adjunction site in (19b) and (32b) rather than the IP. The reason is that the subject seems to always c-command the adverbial clause:

- (35) a. *He₁ became sick because Bill₁ ate spoiled oysters
b. *He₁ becomes sick if Bill₁ eats spoiled oysters

If the BECAUSE- and IF-clauses were adjoined to the IP, the matrix subject would not c-command (and illicitly bind) the subject of the adverbial clause and the sentences would be grammatical.

1.3 *How does the IF-clause appear sentence-initially?*

In the previous sections we saw that a sentence-final IF-clause can be adjoined to the I-bar or to the VP. In this section I will address the

question of whether one of those two adjunction sites is the source of the sentence-initial IF-clause. In other words, I will address the question of whether (36a) is derived from (36b) by movement of the IF-clause to a sentence-initial position or whether it is base-generated there:

- (36) a. If it rains, Peter takes the dog out
b. Peter takes the dog out if it rains

We will see that both possibilities are realized. In other words, there is evidence that the IF-clause can be base-generated sentence-initially, as well as evidence that it can move there.

The argument that shows that the IF-clause can be base-generated sentence-initially is based on the fact that reconstruction of the sentence-initial IF-clause to a sentence-final position is not necessary. Obviously, this argument is of some value only if reconstruction to the site of base-generation is obligatory. That this is the case can be seen in constructions where a derivational account is indisputable:

- (37) a. *₁[Take Peter's s₁ dog out]₂ though he₁ may EC₂, ...
b. *₁[Which friend of Peter's s₁'s]₂ does he₁ like EC₂?

The sentences in (37) are ungrammatical because the sentence-initial constituents appear there by movement and when they get reconstructed in their base-generated positions, the pronoun he will illicitly c-command Peter, resulting in Binding Condition C violations. If we apply this test to the sentence-initial IF-clause, we see that no Binding Condition C violation occurs:

- (38) a. If Bill₁ eats spoiled oysters he₁ gets sick
 b. *He₁ gets sick if Bill₁ eats spoiled oysters

If reconstruction to a sentence-final position were necessary in (38a), then this sentence should be ungrammatical, just as (38b) is. The fact that reconstruction is not obligatory in (38a)⁹ as it is in (37a,b) indicates that base-generation in the sentence-initial position is an option.

The above argument is strengthened when we consider cases where the IF-clause *has* moved and see that reconstruction is, as expected, obligatory. The IF-clause can move out of its sentence. The following sentences should be understood with the IF-clauses construed below the matrix verb (I put the matrix verb in the past tense to make this construal easier):

- (39) a. If it rains Mary believes⁹ that Bill will come
 b. said
 c. heard
 d. assumed

That this is movement and not base-generation can be shown by the fact that the relation is blocked by islands. It cannot get out of a factive island or an inner island, showing this way typical behaviour of adjunct

⁹ For some reason that is obscure to me, this sentence is degraded if the verb believe is in the Past tense.

movement (the '*' is for the reading where the IF-clause is understood below the matrix verb):

- (40) a. *If it rains Mary regreted that Bill will come
b. * forgot
c. * resented
d. * recognized

(41) *If it rains Mary didn't say that Bill will come (contrast with (39b))

It also obeys the Complex Noun Phrase Constraint and the Wh-island Constraint:

- (42) a. *If it rains Mary heard the rumour that Bill will come
b. *If it rains Mary wondered whether Bill will come

Since the IF-clause in (37) appears there by movement, it is expected that reconstruction is obligatory. This expectation is verified:

(43) *If John₁ is sick, he₁ thought that Bill will visit

The ungrammaticality of (43) shows that when an IF-clause has moved, it must reconstruct to the position it was base-generated in. Looking more carefully at (43), we see that it shows only that the IF-clause reconstructs to a point below the pronoun he. It does not determine whether reconstruction is to a sentence-initial or sentence-final position with respect

to the clause Bill will visit. The grammaticality of (44), however, indicates that it reconstructs to a sentence-initial position:

(44) If John₁ is sick, Mary said that he₁ takes aspirin

From the fact that reconstruction is obligatory (as evidenced by (43)) and from the grammaticality of (44) we can conclude that the IF-clause can reconstruct to the sentence-initial position in its clause since a sentence like (45) is ungrammatical:

(45) *He₁ takes aspirin if John₁ gets sick

In other words, cases of long-distance movement of an IF-clause have a double significance. On the one hand they show that moved IF-clauses reconstruct obligatorily into the clause they are extracted from, confirming the hypothesis that movement entails obligatory reconstruction. On the other hand, by reconstructing to the sentence-initial and not the sentence-final position of that clause, long-distance movement shows that IF-clauses can be base-generated sentence-initially. This confirms the conclusion reached in the discussion of (38a,b) above, that base-generation sentence-initially is an option. We have not determined this option to be the only one, however, and we will now see that a derivational account is also required¹⁰.

¹⁰ There is an inconclusive argument that can be made in favour of base-generation sentence-initially being an option for the IF-clause. This has to do with inner islands. We saw in the main text that in long-distance movement of IF-clauses, inner islands are obeyed. We have also seen that a sentence like (i) is grammatical (and unambiguous):

(i) If it rains, Peter will not fix the car

First of all, consider sentences like (46), which contain anaphors in the sentence-initial IF-clauses:

- (46) a. If pictures of himself are on sale, John will be happy
b. If pictures of each other are on sale, John and Bill are happy

We have already seen that when the IF-clause is sentence-initial, it is not c-commanded by the matrix subject. However, the anaphors in (46a,b) are acceptable, indicating that they are c-commanded by the matrix subject at some level of derivation. Whether this level is at D-structure or at LF after reconstruction to the original trace, the point is the same: the IF-clause originated at a sentence-final position.

The same point can be made if we consider bound variable anaphora. In order for a pronoun to receive a bound variable reading, it must be c-commanded at LF by the quantifier that binds it. Consider the following sentences¹¹:

If movement were the only possible account for a sentence-initial IF-clause, (i) should have been ungrammatical. However, this argument is inconclusive, because the grammaticality of (i) could also be due to the IF-clause being moved sentence-initially from the position above negation (as in (32b)) and not from the VP-adjoined position. Since this movement would not cross negation, it would not be constrained by inner islands.

¹¹ Not all quantificational elements behave alike for all speakers for reasons that are unclear to me. Contrast (50a), (50b) and (51b) with (i), (ii) and (iii) respectively :

- (i) *John scolds no woman₁ if her₁ son is late
(ii) *If her₁ son is late, John scolds no woman₁
(iii) *If John scolds his₁ mother no boy₁ gets upset

- (47) a. *His₁ mother gets upset if every boy₁ is late
 b. *If every boy₁ is late, his₁ mother gets upset
- (48) a. Every boy₁ gets upset if his₁ mother is late
 b. If his₁ mother is late, every boy₁ gets upset
- (49) a. *John scolds his₁ mother if every boy₁ is late
 b. *If every boy₁ is late, John scolds his₁ mother
- (50) a. John scolds every woman₁ if her₁ son is late
 b. If her₁ son is late, John scolds every woman₁
- (51) a. Every boy₁ gets upset if John scolds his₁ mother
 b. If John scolds his₁ mother, every boy₁ gets upset
- (52) a. *His₁ mother gets upset if John scolds every boy₁
 b. *If John scolds every boy₁, his₁ mother gets upset

The acceptability of (48a) and (51a) is no mystery: the QP every boy c-commands the pronoun already at S-structure. In (48b), (50a), (50b) and (51b) the QP does not c-command the pronoun at S-structure and the acceptability of these sentences must therefore be due to c-command obtained at LF¹². One way this LF c-command relationship can be obtained

¹² LF-movement of the QP cannot save (47a), (47b), (49a), (49b), (52a) and (52b) because for the QP to reach a position from which it can c-command the pronoun it would have to move out of the IF-clause adjunct, which is not permissible.

is by the QP raising to a position from which it c-commands the IF-clause, thereby binding the pronominal contained within it:

(53) a.

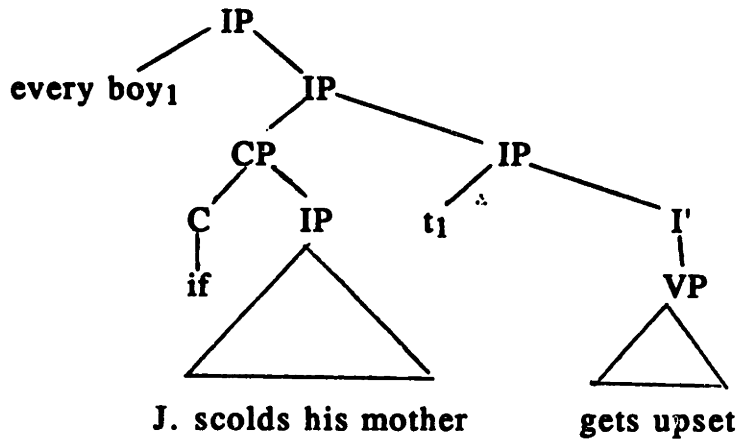

b.

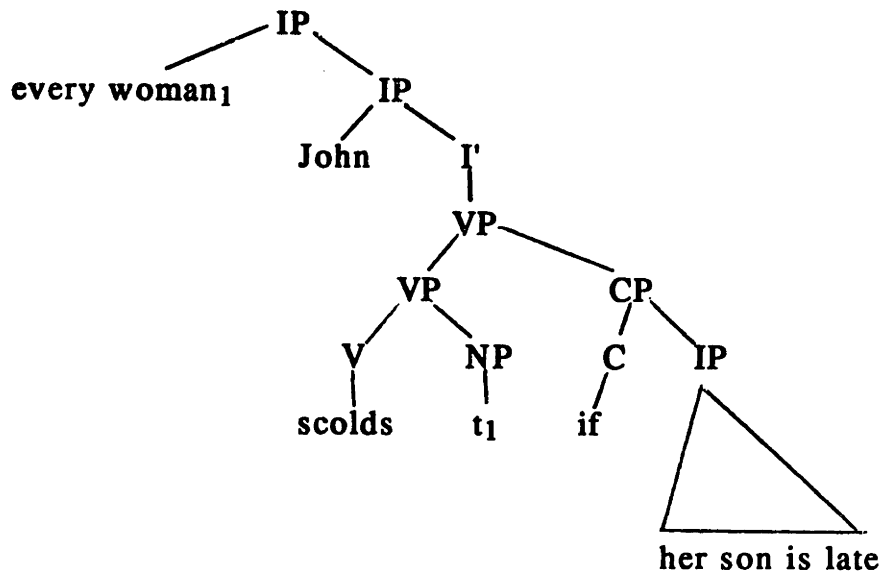

Whether the IF-clause is sentence-initial or sentence-final, the QP can raise to a position in the tree from where it can c-command it. These structures are Classic Weak Crossover configurations, but this is not necessarily an

argument against such an account, because as Stowell (1990) has observed, no WCO violations occur when the pronoun is contained inside an adjunct.

Another way to account for LF c-command in (48b) and (51b) is by reconstructing the IF-clause to a sentence-final position thereby putting the pronoun in the c-command domain of the QP. This would not alleviate the need for QR, however. First of all, depending on the theory, QR might be necessary prerequisite for quantifiers to be interpretable. But second, and more importantly, mere reconstruction would not automatically put the pronoun inside the c-command domain of the QP in (50b), just as it isn't in (50a), given that the matrix object never c-commands the IF-clause (Section 1.1)¹³. In other words, even if reconstruction is a necessary step towards obtaining the bound variable readings in the sentences under discussion, it will have to be followed by QR.

We are in effect, then, dealing with the following two possibilities to obtain LF c-command for the bound variable readings: either QR applies to the S-structures in (47)-(52), or reconstruction of the IF-clause applies first, followed by QR. There is, in fact, evidence that shows that the second option is the actual one. If reconstruction were necessary to obtain a bound variable reading then if reconstruction should yield a Binding Condition C violation in such a case, there would be a conflict. This prediction is borne out:

(54) *If his₁ mother invites Mary₂, she₂ yells at every boy₁

¹³ From (50a), where the issue of reconstructing first does not apply, we see that whichever account is correct, Stowell's observation about lack of WCO violations in adjuncts is still relevant.

The QP-object would have to raise in order to be able to c-command the IF-clause, giving again a configuration that resembles the ones of WCO violations.

The bound variable reading in (54) is not possible. If QR of every boy applied to the S-structure configuration, we would have no account of this. But if reconstruction were required first, it would put Mary in a position where it would illicitly be c-commanded by she. The ungrammaticality of (54) thus indicates that reconstruction is obligatory in order to obtain the bound variable readings in (48b), (50b) and (51b). But the very fact that reconstruction can take place shows that there is a trace of the IF-clause in a sentence-final position, which in turn means that the sentence-initial IF-clause can have been moved to that position from the sentence-final position.

We have shown, then, that an IF-clause can be base-generated in sentence-final and sentence-initial position, as well as that it can move from the former to the latter.

1.4 *Inside the IF-clause*

English is one of many languages in which the marker of the IF-clause is isomorphic with that of an interrogative complement¹⁴. Without going in detail into the structure of embedded questions, there are some superficial similarities between embedded interrogative IF-clauses and

¹⁴ According to Traugott (1985), this is one of the five most common sources for a conditional marker, the others being words of epistemic and optative modality; copula construction; words marking something as known or given; and words that are temporal in origin.

conditional IF-clauses. It will appear that both are introduced by a CP whose head is the complementizer if. Both interrogative and conditional IF-clauses are islands for extraction even though their [SPEC,CP] appear to be empty. In the case of conditional IF-clauses this will be attributed to their status as adjuncts; in the case of interrogative IF-clauses, it will be argued that islandhood should be attributed to there being an empty operator in the [SPEC,CP].

1.4.1 *What and where is if?*

For Emonds (1985) conditional if/si and interrogative if / si are the same word, but while an embedded interrogative is an IF-clause inside V-bar, a conditional is an IF-clause outside V-bar. Also, for him whether and if are expansions of the same clausal preposition (what he argues complementizers are):

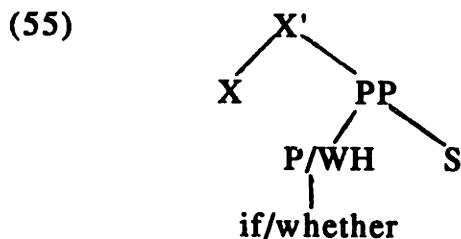

However, in a footnote (p. 286 fn 4) he points out that "[p]ossibly, whether is a fronted sentence adverb (the WH form of either/so/too), and is not strictly a COMP". He says this because of differences between whether and if (for discussion of which he refers the reader to Yim (1984)):

(56) a. Did he know whether/*if or not she won the award?

- b. I am uncertain as to whether/*if you should attend
- c. Debates about whether/*if the weather is changing are futile
- d. You should tell me whether /*if to go to the meeting

Irrespective of the account of the sentences in (56), the fact that whether can never appear associated with the protasis of a conditional¹⁵ seems to point to a difference between the functional projection introducing an embedded question and the functional projection introducing a protasis, other than the one that Emonds mentions (their site of attachment).

Kayne (1990) also takes if/si to be lexically the same in questions and conditionals. But he specifically distinguishes whether from interrogative if. He argues that if, unlike whether or other WH-words, stands in the head of a CP:

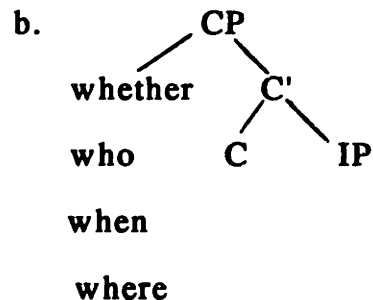
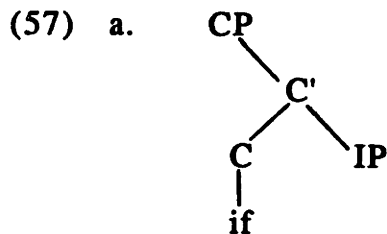

His main argument is that while the WH-words in (56b) can introduce an infinitival complement, if cannot:

¹⁵ Except in what are called concessive conditionals, as in (i):

(i) Whether or not you come, I'll watch that movie on the VCR.

- (58) a. I don't know whether to leave (or not)
 b. I don't know who to invite
 c. I don't know when to leave
 d. I don't know where to go
 e. *I don't know if to go

According to Kayne, this is because if illicitly governs PRO in [SPEC,IP]. On the other hand, the WH-words stand in [SPEC,CP], as in (57b), from where they cannot govern (the SPEC of) IP and therefore PRO is permitted in that position.

If it is correct that both interrogative and conditional IF-clauses are introduced by a CP with if as its head, as in (59):

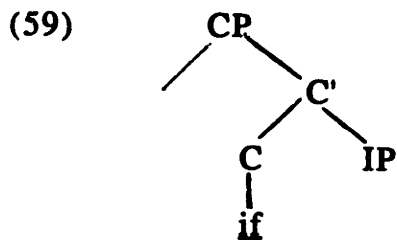

then interrogative and conditional IF-clauses both appear to have an empty [SPEC,CP]. This might make certain predictions for extraction from within those clauses. Extraction from a conditional IF-clause is not possible:

- (60) a. *Who will you tell me if Mary sees?
 b. *How/*when/etc will you be happy if Mary fixes the car?

Eventhough it has an available escape hatch, a conditional IF-clause is a barrier for extraction since it is an adjunct and therefore not L-marked (Chomsky (1986), Rizzi (1990) and many others).

However, embedded interrogatives introduced by **if** should not be an island for extraction, since the [SPEC,CP] position is not filled and since, unlike conditional IF-clauses, they are L-marked by the higher verb. But we see that also interrogative IF-clauses are islands. In fact, we see that regardless of whether **whether** or **if** introduces an interrogative, the latter is still an island:

- (61) a. ?Who did you wonder if Mary saw?
b. *Who did you wonder if saw Mary?
c. *When/*where/*how did you wonder if Mary fixed the car?

- (62) a. ?Who did you wonder whether Mary saw?
b. *Who did you wonder whether saw Mary?
c. *When/etc did you wonder whether Mary fixed the car?

There seems to be no difference in grammaticality between the sentences in (61) and the corresponding ones in (62). This might be unexpected, given that it has just been argued that **whether** stands in the [SPEC,CP] and that **if** in (61) has an escape hatch on its left. One would expect that (61a) and (61c) be grammatical (arguably, (62b) is a that-trace violation). There is an answer to this question that will permit us to maintain the position that in both interrogatives and conditionals **if** stands in the head of the CP. This answer is provided by Larson (1985).

Larson (1985) adheres to the widely held assumption (following Karttunen (1977)) that an embedded yes-no question is a covert alternative question. In this account, a sentence like (63a) represents an underlying structure like (63b) or (63c):

- (63) a. I asked whether Bill should leave
b. I asked whether or not Bili should leave
c. I asked whether Bill should leave or not

He also adheres to the independently made observation that or has scopal properties and argues that with every occurrence of or, there is always a either, a whether (the [+WH] counterpart of either) or a null equivalent ("OPerator") to mark its scope. This means that in the sentences in (63), whether serves to mark the scope of or.

Larson argues that an interrogative introduced by if has the same semantics as a clause introduced by whether and suggests that in an interrogative introduced by if there is the null counterpart of whether (OP) marking the scope of covert or¹⁶. So (64a) and (64b) have the structure of (65a) and (65b) respectively (adjusting the notation of the phrase-markers):

- (64) a. I wonder whether Bill should leave
b. I wonder if Bill should leave

¹⁶ There is the obvious question of why the disjunction part or not can never appear overtly immediately after if. Compare the ungrammatical expansion of (55a) to (i):

(i) Did he know if she won the award or not?

As far as I can tell, Larson does not address this.

(65) a. I wonder

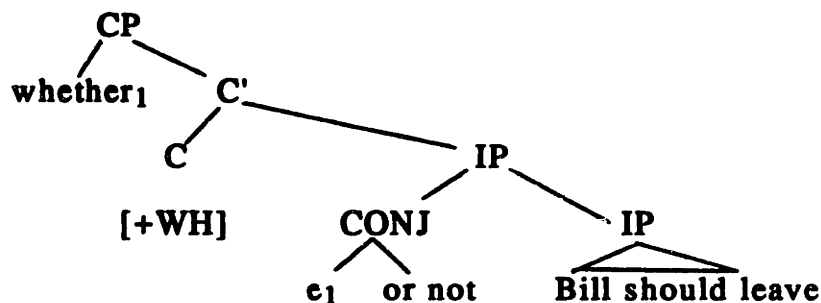

b. I wonder

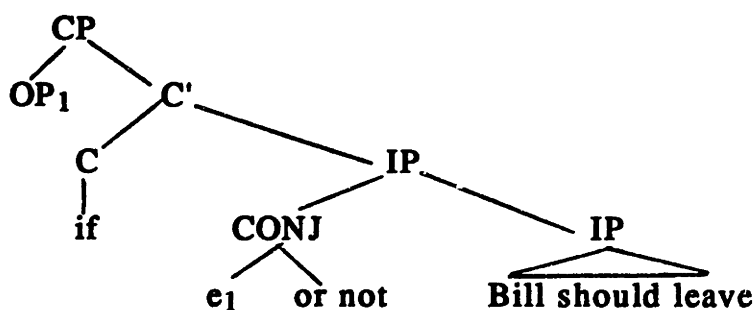

In (65a) and (65b) [+WH]/*if* is the head of the CP which marks it as an interrogative, and thereby permits it to satisfy the selection requirements of the higher verb. The scope of the (covert) *or* is marked by *whether*/*OP*.

Summarizing the account of Larson (1985), the functional projection (containing *if*) that introduces an embedded question is always associated with a covert alternative question with *or not*, as well as with a marker of the scope of *or* (the null counterpart of *whether*), which stands in the [SPEC, CP] to the left of *if*¹⁷. This account provides us with an answer for why an embedded clause introduced by *if* shows the same extraction pattern

¹⁷ Obviously, the semantics of the conditional IF-clause is different and the functional projection (also containing *if*) which introduces it does not contain the null counterpart of *whether*. In other words, although there is only one *if*, the two types of IF-clauses do not just differ on their attachment sites as Emonds argues.

as an embedded clause introduced by a WH-word: the [SPEC,CP] position in both (65a) and (65b) is filled up, by OP in (61) and by whether in (62)¹⁸
 19. As a result, both types of embedded clauses behave as islands for extraction. This account permits us, then, to adopt the proposal that in both interrogative and conditional IF-clauses the complementizer if stands in the head of the CP, without considering the extraction pattern as contradicting this position.

¹⁸ I think that, however bad (61) and (62) are, they are somewhat better than corresponding sentences where the WH-word is "contentful":

- (i) (*)*Who₁ do you wonder when Mary saw t₁
- (ii) **Where₁ do you wonder who saw Mary t₁

I don't know why this should be so, but the proposal I'll make in the upcoming footnote might offer a way out.

¹⁹ There is a slight modification of Larson's account that might be possible and I am particularly grateful to David Pesetsky for discussing this idea. Instead of adopting his proposal that embedded interrogative complement in English can be introduced by the pair whether/[+WH] or the pair OP/if, one might argue that whether is OP, and that if is the [+WH] feature (or the English interrogative complementizer). In effect this means that at S-structure all embedded WHETHER- and IF-interrogatives have the same structure (i):

- (i) [whether [if [IP]]]

But the doubly filled COMP filter of English forces one of the two elements to delete, yielding some clauses that are introduced by whether and some that are introduced by if. For embedded questions introduced by other WH-words, we can assume that they are underlyingly as in (ii):

- (ii) [who [if [IP]]]
 [where [if [IP]]]
 etc

Again the doubly filled COMP filter forces deletion of one element. But unlike in the case of (i), in (ii) it is if that must delete, because the deletion of the other element is not recoverable. The deletion of whether as a scope marker is recoverable in the sense that its S-structure position is predictable: it is always the [SPEC,CP]. This proposal would make English similar to some dialects of Dutch, where the equivalent of (ii) can appear at S-structure (Koster (1986)).

Returning briefly to the data in the previous footnote, it is possible that the present account provides an explanation for the fact that (i) and (ii) of that footnote are worse than (61) and (62) of the main text: the predictability of the scope operator (whether) might offer some kind of window for extraction.

1.4.2 Does *if* have lower construals?

Following the arguments mentioned in the previous section, I will henceforth assume that conditional *if* is a complementizer and is followed by an IP²⁰. In this section I would like to make a short digression to address a question posed by Geis & Lycan (1989). They argue that "if p,q" should be paraphrased as "in any circumstance in which p, q". Moreover, they consider a conditional IF-clause to be a (free) relative clause, just like adjunct clauses introduced by when and where are. Since, in fact, their main thesis is to assimilate IF-clauses to relative clauses, they have to explain the contrast between (66) and (67a, b):

(66) Mary will be seen if John tells the press that Bill will write that Peter will be injured.

(67) a. Mary was seen when/where John told the press that Bill had written that Peter had been injured.

²⁰ Unlike other CPs, the CP headed by *if* can never recurse (Schwartz and Vikner (1991) and references therein for CP recursion). Embedded NEG-inversion (i) and embedded topicalization (ii) are argued to be cases of CP-recursion in English:

- (i) Mary knows that never in his life has John seen such good GRE scores
- (ii) Mary knows that those books Bill has read

neither NEG-fronting nor topicalization are permissible inside an IF-clause:

- (iii) *If never in his life has John seen such good GRE scores, ...
- (iv) *If this book John has read, ...

I'll return in Chapter 5 for an account of this.

- b. Mary will be seen in any circumstance in which John tells the press that Bill will write that Peter will be injured.

The contrast between (66) and (67a,b) that Geis and Lycan worry about is the following. In (66), if permits only the highest construal (as indicated by underlining); that is, it can only be interpreted as "Mary will be seen in any circumstances in which John tells the press that ...", and not as "Mary will be seen in any circumstances in which, according to John's report to the press, Bill will write that ..." But (67a,b) do permit lower construals. In (67a) when and where can be understood as modifying any of the underlined verbs, and so can in which in (67b). In other words, these phrases can be taken as binding a variable in any of the clauses that are embedded under them (modulo islands, of course).

There is a way to account for the contrast in question²¹. The standard explanation of lower construals of a constituent is the possibility of base-generation in and extraction from those lower positions it is construed (interpreted) in. This way the contrast between (66) and (67a,b) reformulates as a contrast between the extractability of when/where and in which and the non-extractability of if. WH-phrases like when, where and in which are maximal projections that move through the [SPEC, CP] position(s) of the clause(s) they are extracted from and can extract long-distance (as long as no islands interfere). On the other hand, if is a (complementizer) head, and as such, its movement is restricted. More

²¹ Geis and Lycan have an account for the contrast between (66) and (67a,b), according to which if introduces an epistemic operator meaning "comes about that", or "becomes known that". This operator cannot take any free variables in its scope and therefore does not permit extraction from below it. However, there are some questions with the judgements, as they themselves acknowledge.

specifically, a complementizer is not a lexical projection. This can be seen from the fact that an IP can never raise and strand the complementizer:

(68) *[John is sick]₁ Bill knows that EC₁

The ungrammaticality of (68) is due to the trace not being head-governed (Noam Chomsky, class lectures 1989). The same would hold for movement of the complementizer itself. It follows that if will not permit lower construals²². In other words, even if one were to claim that if

²² In embedded questions matters are slightly different. When they are introduced by a WH-word other than whether the predicted ambiguities arise:

(i) I don't know when/where Mary said Bill would call

But unlike in adjunct clauses, if in embedded questions does seem to co-occur with multiple readings. One has to be careful with what these possible readings are. While in sentences like (i) the different possible readings are transparent, in embedded IF-clauses they are subtler. Recall from the short discussion of Larson (1985) that embedded questions always contain an or whose scope is marked by whether or a null counterpart which marks the scope of or. He also argues that whether or its counterpart have moved from the position close to or. The prediction then is that if there is more than one or in the embedded question, there will be ambiguities with respect to which or whether is the scope marker of.

(ii) John asked whether Peter or Mary had said that Bill should retire or resign

If whether is construed with the higher or, the sentence has the reading in (iii), and if whether is construed with the second or it has the reading in (iv):

(iii) John asked "did Peter say that Bill should resign or retire, or did Mary say that Bill should resign or retire"

(iv) John asked "did Peter or Mary say that Bill should resign, or did Peter or Mary say that Bill should retire"

Reading (iii) would be the higher construal of whether and reading (iv) the lower one. Obviously in conditionals nothing like this happens, since there if (or the CP it heads) is not associated with a scopal element.

appears where it does because of movement, it cannot have moved out of a CP below the one that it heads at S-structure²³.

So far I have argued that the contrast between (66) and (67a,b) is due to WH-phrases being maximal projections that can extract from (i.e. bind a variable in) different positions. On the other hand if is simply a complementizer and therefore cannot move or bind a variable. In its aforementioned behaviour (or better put, lack thereof), if is similar to other complementizer-like elements. Notice the lack of lower construals of because and (causal) since (again, possible construals are indicated by underlining):

²³ Irene Heim (p.c.) points out that this account does not exclude the possibility that there is a null operator that is base-generated inside the clause and moves to the [SPEC,CP] to the left of if from where it binds a "circumstance" variable, using the terminology of G & L. If such a null operator existed, it could be extractable from lower clauses giving lower construals. There might be two possible ways to answer this. One might argue that such an operator can only bind a variable locally, i.e. only in the clause that immediately follows it. The circumstance variable of the more deeply embedded clauses would be bound by something like existential closure (Heim (1982)). In effect then, this operator would be compatible only with a clause introduced by if. Alternatively, one could argue that all null operator chains have a position to which Case is assigned. This position could be the foot of the chain, as in *tough*-movement, or the head of the chain, as in the case of before and after clauses. In the case of an IF-clause the null operator chain could not be assigned Case in any of its positions and it is therefore ruled out. If this is correct, it would account for the contrast in (i):

- (i) a. I met him in the place (where) I met Mary
b. I met him *(where) I met Mary

In (ia) where does not have to appear because the null operator is licensed through its association with the Case-assigned the place. In (ib), however, the null operator has no access to a Case-assigned position at all and can therefore not appear. Such an account raises questions about the null counterpart of whether, as argued for by Larson (1985): either it is not a null operator of the relevant kind, or the alternative account of footnote 19 should be chosen.

The two possible replies to Heim's question have different ramifications. In the first one, a null operator is permitted, but it can only bind a variable locally, explaining thereby the absence of lower construals in conditional IF-clauses. Within the framework of the second reply, no null operator is permitted at all.

(69) I left because/since John wrote that Mary left²⁴

So far I have followed Geis and Lycan in saying that if (and now because and (causal) since) permit only the highest construal. But this might, in fact, be misleading. Saying that these elements can be construed only with the highest element implies that they bind a variable in the highest clause and it is not clear that this is right. One important difference between WH-words and because and since is not just the absence of lower readings in the latter two cases, but also the following:

- (70) a. Mary left when the bell rang
b. Mary saw John where Bill met Peter
- (71) a. Mary left because the bell rang
b. Mary will see John since Bill will see Peter

The WH-words of (70) connect two time/place variables; for example, in (70a), the time of Mary's leaving is the time of the bell's ringing. Similarly

²⁴ The word since should only be taken here in its causal meaning. In Chapter 2, I discuss some differences between causal since and because. In its temporal reading since does permit lower construals:

- (i) I have been here since John said that Peter claimed that Mary arrived

In its temporal reading it seems similar to the temporal prepositions before and after as in the discussion of Larson (198?). This is witnessed by the fact that as a preposition, since has only its temporal reading. Sentence (ii) can only mean (iii), not (iv):

- (ii) John has been here since the flood
(iii) John has been here since the time the flood happened
(iv) John has been here because of the flood

in (70b), the place of Mary's seeing John is the place of Bill's meeting Peter. On the other hand, in (71a) the reason for which Mary left is not the reason for which the bell rang, and in (71b) the reason for which Mary will see John is not the reason for which Bill will meet Peter. This is a reflection of because and since not binding any position at all inside the adjunct clauses they introduce, that is, they are sentential functions (like the truth-functional connectives) and not quantifiers. In other words, it is misleading to say that because and since permit only the highest construal. The fact is that they have no construal at all, or put differently, the issue of construal does not arise at all.

I have argued so far that the presence (or absence) of lower construals is correlated, better yet, is the same as the presence (or absence) of any construal at all. This makes the following prediction: if we find a maximal projection (instead of ahead/complementizer) that talks about a reason for the predicate of the matrix clause, we predict that lower construals will be possible but also that the reason of the matrix predicate will be identified with the reason of the clause in which the construal takes place. This is borne out, (72) is multiply ambiguous and it says that whatever caused my leaving also caused the underlined predicate:

(72) I left for the reason for which Bill said that Mary left

The relevant difference, then, between maximal projections and sentential functions like because is not that the former permit lower construals while the latter permit only the highest construal, but that the former permit construals, while the latter do not at all. This account makes the correct prediction that a sentence like (73) is ambiguous:

(73) I left for the reason that you left

On one reading that introduces a relative clause, whose relative clause construes in the clause that follows and gives the reading "I left for the same reason that you left". On the other reading that introduces a complement clause and therefore does not permit any construal at all. On this use of that, sentence (73) means something like "I left because you left" (and you may have had your own reasons for leaving, known or unknown to me)²⁵.

²⁵ The word while also belongs to the paradigm discussed. It does not permit lower construals, i.e. (i) cannot be interpreted along the lines of (ii):

- (i) I was laughing while you were telling me that Mary was sleeping
- (ii) I was laughing while Mary was sleeping (as related by you)

In the present account this would mean that while is not a maximal projection but a complementizer. Indeed, while does not introduce embedded questions, nor relative clauses:

- (iii) *I don't know while to study
- (iv) *I don't know while I should study
- (v) *I slept at the time/during the period while John was out

Moreover, while doesn't have an interrogative counterpart, nor can it be stranded in an echo-question. All this doesn't prove anything; it merely is consistent with while being a head and not a maximal projection, thereby predicting the lack of ambiguity in (i). However, I do not think that the above give a full explanation of the behaviour of while. First of all, it behaves differently from the other heads under discussion in that it does permit a construal. Sentence (iv) says something about the period during which John was sleeping:

- (vi) I was sleeping while John was sleeping

This means that the lack of ambiguity in (i) is not due to the absence of a construal of while (as was the case of because, causal since and if), but due to a (genuine) highest construal only. But the main reason for which I don't think we're dealing here with an idiosyncratic behaviour of while, is that if we replace while with when in sentence (i), a lower construal of when is very hard, if not impossible to get:

- (vii) I was laughing when you were telling me that Mary was sleeping

Finally, in order to ask this same question for if, let's consider (74):

(74) John will leave if Peter calls Mary

We have already seen that if behaves like because and since in not permitting lower construals. The question is whether it behaves like them in having no construal at all, or whether it does permit a construal, possibly due to the reason suggested in footnote 22. The answer depends on what the right paraphrase of an IF-clause is and I think that the intuitions here are not very clear. If the right paraphrase for sentence (74) is that John will leave in any circumstance in which Peter calls Mary, then the circumstances in which John will leave are a superset of the circumstances in which Peter calls Mary and if has a construal. But if the right paraphrase is that John will leave under the condition that Peter calls Mary, then nothing is said about the conditions under which Peter will call Mary. In this interpretation if has no construal at all. The question of

Sentence (vii) cannot be interpreted along the lines of "I was happy during Mary's sleep". But this is obviously not due to an idiosyncratic behaviour of when, which as we've seen readily permits lower construals. Moreover, as in (i) when does permit a construal inside the embedded clause, i.e. it says something about the time during which you were talking to me. What I think we're dealing with here is an island for extraction of when which is due to the progressive. If we take the progressive out of (vii), when again permits lower interpretations:

(viii) I was laughing when you told me that Mary was sleeping

If there is such an island effect, then we can at the same time explain why there are no lower construals, as well as why the highest construal is possible. This island effect may not be restricted to the progressive as an inflectional form but generally associated with durative events or states (of which the progressive is one manifestation). If this is correct, then the behaviour of while may be due to the same phenomenon, since its meaning (roughly "during") is particular to durative events or states. I will leave development of this suggestion for some future occasion.

which of these two paraphrases is correct I will leave for some future occasion.

2

CHAPTER 2

TYPES OF CONDITIONALS

2.0

In the previous chapter I described some syntactic characteristics of conditional sentences. The ones that adhere to the pattern described there I will refer to as "hypothetical" conditionals (HCs). In this chapter I will describe two types of conditional constructions that show a different syntactic behaviour.

2.1 *The Relevance Conditional or Conditional Speech Act*

The first such conditional is the one often referred to in the literature as the "relevance conditional" (RC) or "conditional speech act". Some examples of this are the following:

- (1) a. If I may be honest, you're not looking good
- b. If you want to know, 4 isn't a prime number
- c. If you want to find Bill, he is usually in his office at this hour
- d. If you're thirsty, there is a beer in the fridge

It is intuitively obvious that the IF-clauses in (1a-d) play a different role from the HC IF-clauses. If the latter can be roughly be paraphrased following Geis and Lycan (1990) (henceforth G & L) as "in any

circumstance in which p, q", it is obvious that the RCs cannot be captured that way. That is, (1b) cannot be paraphrased as (2a), nor (1d) as (2b):

- (2) a. In any circumstance in which you want to know, 4 isn't a prime number
- b. In any circumstance in which you are thirsty, there is a beer in the fridge

The IF-clauses in (1a-d) specify the circumstances in which the consequent is relevant (in a vague sense, also subsuming circumstances of social appropriateness), not the circumstances in which it is true. To the extent that something like G & L's paraphrase is usable here, it would be along the lines of (3a) and (3b):

- (3) a. In any circumstance in which you want to know, it is relevant/appropriate to tell you that 4 isn't a prime number
- b. In any circumstance in which you are thirsty, it is relevant/appropriate to tell you that there is a beer in the fridge

As van der Auwera (1986) puts it, the IF-clause contains a sufficient condition for a speech act containing the main clause. Or, we can say that the RC IF-clause contains a felicity condition for the use of the consequent as a speech act.

The above paraphrase of the RC is reminiscent of the "Performative Hypothesis" (PH) of Ross (1970) and Sadock (1974). Without going into the different versions of the PH or its advantages and disadvantages (see Levinson (1983) for an overview), I will briefly outline the basic idea

behind it and its relevance to the RC. According to the PH, every sentence is embedded under a performative predicate (the "performative prefix") which is roughly of the form "I tell you that". So for example a sentence like it is raining would be basically of the form I tell you that it is raining. While the PH was proposed within the context of a debate about speech acts, there were also syntactic arguments that were used in its favour. For example, the performative prefix was said to provide antecedents for first and second person anaphors, as in (4a):

- (4) a. (I tell you that) "people like myself/yourself/ourselves are hard to find"
b. (I tell you that) *"people like himself are hard to find"

In (4b), on the other hand, the anaphor "himself" is not licensed because the performative prefix does not contain a third person antecedent for it; it contains only the speaker and hearer of the performative clause.

Another argument that was proposed in favour of the PH was the presence of adverbial clauses that appeared to be modifying the performative clause, such as frankly in (5a) and because I have to be home by eight in (5b):

- (5) a. Frankly, you look horrible
b. How late is it, because I have to be home by eight?

By now it should be apparent why and how we can expand the idea behind the PH to RCs. The RC IF-clause would be the protasis not of the phonologically overt consequent clause, but of the performative prefix. In

other words, the real consequent of a sentence like (1b) is not the one shown there but the one in (6):

(6) If you want to know, I tell you that 4 isn't a prime number

Within this way of presenting the issue, the RC-IF clause is outside the assertion, the latter being only the sentence embedded under the performative prefix. This leads us to another intuitive difference between the RC and the HC.

An important difference between the HC and the RC, and as just mentioned, one that is consistent with the above considerations, is that in the HC both its IF-clause and its consequent are part of the assertion, but in the case of the RC only the consequent is the assertion. That the RC IF-clause is not part of the assertion is confirmed by the fact that it cannot be negated. That is, denial of the truth of an HC (as in (7)) can be continued as in (7B), but denial of the truth of an RC cannot:

(7) A: If it rains Peter takes his dog out

B: That's not true, he takes his dog out if it's sunny

(8) A: If I may be honest you're looking awful

B: That's not true #I look awful if you may be deceitful

Another way to show that the RC IF-clause is not part of the assertion is to contrast what speaker B commits himself to by agreeing with A in (9) to what he commits himself to in (10):

(9) A: If it rains, Peter takes his dog out

B: I agree

(10) A: If I may be honest, John is not looking good

B: I agree

It is obvious that in (9) B agrees with A that Peter takes his dog out if it rains, while in (10) B agrees that John is not looking good.

There are many syntactic differences between the RC and the HC. First of all, unlike the HC, which can contain conditional then, the RC cannot:

(11) If it rains then Peter takes his dog out

(12) a. #If I may be honest then you're not looking good

b. #If you want to know then 4 isn't a prime number

Sometimes it is possible to force an interpretation on an RC which contains then, but as is obvious in (13), it loses the RC interpretation and are understood as HCs:

(13) If you're thirsty then there is a beer in the fridge

If an interpretation is forced on (13) it is understood that there is a connection between my thirst and the appearance (as if by magic) of a beer in the fridge. This is an HC interpretation. Obviously, such an interpretation cannot be forced on (12b). In Chapter 4 I will propose an account of the distribution of then that explains this contrast.

A second difference between the RC and the HC shows up in languages with productive V2, like Dutch. In Dutch the HC IF-clause behaves as the first element in a V2 construction, forcing the verb to immediately follow it:

(14) a. Als Jan weggaat ga ik ook weg
if John away goes go I also away
'If John goes away I will go away too'

b. *Als Jan weggaat ik ga ook weg

But a sentence-initial RC IF-clause does not have this effect:

(15) a. Als je het wil weten 4 is geen priem getal
if you it want know 4 is no prime number
'If you want to know 4 is not a prime number'

b. *Als je het wil weten is 4 geen priem getal

As before, if V2 is forced on a RC, it is interpreted as an HC:

(16) Als je honger hebt is er een boterham op de tafel
if you hunger have is there a sandwich on the table
'If you're hungry there is a sandwich on the table'

(16) is understood along the lines of (13), i.e. with an HC interpretation, however odd. Of course such a reading cannot be forced on (15b).

Since the IF-clause of the RC is related to the rest of the sentence as a speech act, it is not surprising that it cannot embed, except under speech act verbs:

- (17) a. John said that if you're thirsty there is a beer in the fridge
b. *John believes that if you're thirsty there is a beer in the fridge

For the same reason, it is not surprising that the RC IF-clause must attach to the IP/CP (not the I-bar or VP), even when it is sentence-final¹. We can see this, first of all from the fact that Binding Condition C seems not to be operative:

- (18) a. (?)He₁ knows where to find me if Bill₁ wants to talk to me
b. Mary and Bill will become rich if each other's photographs are published
c. Mary and Bill will become rich if stories about themselves are published
d. *Mary and Bill will know where to find me if each other's friends want to talk to me
e. *Mary and Bill will know where to find me if stories about themselves are told

¹ I say "IP/CP" because, like the HC IF-clause, the RC IF-clause can precede a question as well as an exclamation:

- (i) If I may be so blunt as to ask, where were you last night?
(ii) If I may say so, what a fool you've been!

From (18a) we can see that the matrix subject does not c-command the IF-clause, otherwise the sentence would be a Binding Condition C violation². This means that the RC IF-clause may attach higher than the HC IF-clause. However, (18a) doesn't show that it *must* attach higher. This is shown by the contrast between (18b,c) and (18d,e). (18b,c) show that an anaphor or a reciprocal inside the HC IF-clause can be bound by the matrix subject, confirming the position that the latter c-commands the sentence HC IF-clause. The unacceptability of (18d,e) makes it clear that this is not the case for anaphors contained inside the RC IF-clause, showing that the RC IF-clause cannot attach lower than the matrix IP/CP.

Second, not only can the RC not be fronted by VP-fronting (as in (19a)), it cannot be stranded by it either (19b), confirming the hypothesis that the RC IF-clause can never appear inside the sentence³:

- (19) a. *look sick if I may say so though John does, he is still one
of the handsomest guys in the department
- b. *look sick though John does if I may say so, he is still one
of the handsomest guys in the department

Summarizing this section, I have briefly described one type of conditional which does not adhere to the syntactic behaviour described in

² The "(?)" is to indicate that this sentence, although not a condition C violation, is somewhat degraded for some speakers. I think that this slight degradation might be due to some "closeness" effect, observed in all cases of backward anaphora.

³ The IF-clauses in (19) improve if the sentences are read as parentheticals. That RC IF-clauses can be incorporated into the sentence only as parenthetical is consistent with their status as modifiers of the performative prefix. Elements modifying the performative prefix, like frankly in the main text, belong to the class of parentheticals (although they do not exhaust it).

Chapter 1. The RC IF-clause specifies some circumstance under which the consequent is relevant or appropriate as a speech act; it is not part of the assertion and therefore does not affect the truth-conditions of the sentence as a whole.

2.2 *The Factual Conditional*

2.2.1 *A first description*

In this section I will describe another type of conditional that behaves differently from the HC. This is the conditional that appears in a conversation like the following:

(20) A: Bill is very unhappy here

B: If he is so unhappy he should leave

It might appear at first sight that what is going on in (20B) is that B accepts the truth of what A just told him. But when we consider sentences like (21) and (22), we see that this characterization is too strong. The acceptance by the speaker can be just for the sake of argument, as in (21), or only as a form of irony, as in (22), where it is conveyed that speaker B seriously doubts that Joe is smart:

(21) A: This book that I'm reading is really stupid

B: I haven't read it, but if it's so stupid you shouldn't bother with it

(22) A: My friend Joe, whom you haven't met, is very smart

B: Oh yeah? If he's so smart why isn't he rich?

What intuitively seems to be the difference between an HC and the conditionals presently under consideration, is that only the latter carry the presupposition that somebody believes the content of the IF-clause to be true. For this reason, I will be referring to them as "factual conditionals" (FCs)⁴. One could say that the relevant characteristic is that the content of the FC IF-clause is presupposed to be at issue in the discourse, resembling thereby the "response-stance" predicates of Cattell (1976). This is reflected in the fact that FC IF-clauses are understood as "if it is true that ...". For example, (20B) is understood to mean "If it is true that he is unhappy, he should leave" and (22B) "If it is true that he is so smart, why isn't he rich?" In other words, the FC IF-clause does not merely specify the circumstances in which the consequent is true, but assumes that the circumstances under which the consequent is true are the actual ones for some person. That unlike the HC, the FC does not specify the circumstances in which the consequent is true can also be shown in the following dialogues, taken from Haegeman and Wekker (1984):

⁴ Although the examples that I've shown are all dialogue fragments, FCs are not restricted to such environments. The principal diagnostic of the FC is that its IF-clause be considered by somebody as true. This is most easily shown in the context of a conversation. However, any context in which the IF-clause can be interpreted as accepted as true by somebody is thereby a context in which the FC can appear.

(23) A: If you like her so much, you should invite her to tea

B: When/Under what conditions should I invite her?

A: *If you like her so much

(24) A: I'll invite her to tea if I see her again

B: Under what conditions/When will you invite her?

A: If I see her again

In other words, (20B) is not paraphrasable as (25), where it isn't acknowledged that somebody holds the circumstances in the IF-clause to be the actual ones, but as (26), where it is:

(25) In any circumstance in which Bill is so unhappy, Bill should leave

(26) In these circumstances, in which according to somebody's belief Bill is so unhappy, the belief that Bill is unhappy implies (the belief) that Bill should leave

I mentioned before that the characteristic of the FC IF-clause is that somebody must believe its content to be true. This somebody can be the hearer, but it doesn't have to be. Instead of (21), we can have (27):

(27) A: I haven't read this book but John is reading it now and he says that it is really stupid

B: I haven't read it either, but if it's so stupid he shouldn't bother with it

In (27) the believer of the IF-clause is not the hearer nor the speaker, but John.

So far we've seen that the person who holds the content of the FC IF-clause to be true can be, but doesn't have to be, the hearer. We will now see that it cannot be the speaker. At first sight, it might appear that the FC IF-clause can be paraphrased with since, so that instead of (20B) we would be able to have:

(28) B: Since Bill is so unhappy he should leave

However, the difference between the FC and a clause introduced by since is that the FC cannot be used if the speaker has direct knowledge of its content:

(29) A (looking out of the window): It's raining

B: If it's raining we shouldn't go out

but not:

B (looking out of the window): since/*if it's raining we shouldn't go out

(from Akatsuka (1986))

This knowledge does not have to have been obtained by perception, as in the above example. Similarly, I cannot say (30); nor on my 21st birthday (31):

(30) # I will invite her if I like her so much

(31) # If I am 21 years old I can do whatever I want.

In both (30) and (31) I would have to use since instead. This means that the believer of the FC IF-clause cannot be the speaker; at most, the speaker might be willing to not contradict it, as in (20) and (21). Although s/he can do so with irony, as in (22), showing that the acceptance is not real⁵.

On the other hand, for since to be used, the content of the clause it introduces must be believed to be true by the speaker, not just by the hearer or a third party. In (20) and (21) since can replace if but then the understanding is that the speaker is willing to consider Bill's unhappiness or the stupidity of the book under consideration as stupid as part of his/her own beliefs. And as we saw in (29)-(31), if cannot replace since if it's obvious that the speaker has a direct way of knowing the content of the IF-clause to be true. Similarly, since cannot replace if in (22) where it's obvious (albeit through irony) that the speaker does not hold the content of the IF-clause to be part of his/her beliefs⁶.

⁵ The position that the speaker cannot be the one who holds the content of the IF-clause to be true is also confirmed in the following minimal pair, due to David Pesetsky:

- (i) a. #If I feel so sick, why am I leaving the hospital?
b. If I am so sick, why am I leaving the hospital?

In (ib) the person whose belief is the content of the IF-clause can be a doctor. The sentence is therefore fine as an FC. In (ia) on the other hand, the believer cannot be the speaker him/herself, thereby making its use unfelicitous or unacceptable. One can force (ia) to be interpreted as an FC, but at most in response to something like You may not realize/admit it, but I know you are feeling sick.

⁶ Schematically speaking, there appear to be different "degrees of acceptance" correlated with different types of adjuncts. For (ia) to be used, it is presupposed that the speaker believes that the IF-clause is true. For (ib) to be used as FC, it is presupposed that someone other than the speaker believes that the IF-clause is true. For (ic) to be used as an HC, nothing is presupposed with respect to who, if anybody, believes that asbestos makes John sick. Finally, for (d) to be used, it is presupposed that the speaker believes that the IF-

2.2.2 FC vs. RC

The FC and the RC have in common that neither of them specifies the circumstances in which the consequent is true. However, there are quite a few differences between the FC and the RC as well. There is, in other words, a three-way distinction between the FC, the RC and the HC.

The first difference between the FC and the RC is a difference in meaning, and it's an obvious one. The FC IF-clause can at most be understood as giving some reason for the content of the assertion. This is different from the RC IF-clause which does not give a reason for the *content* of the consequent, but some appropriateness condition for the consequent as a *speech act*. As we've already seen, the RC IF-clause specifies the circumstances in which the consequent is felicitous as a speech act.

Another difference between the FC and the RC is that the former can take conditional then. Compare (12a-b) to (32):

(32) A: Bill is very unhappy here

B: If Bill is so unhappy then he should leave

clause is false (although see Stalnaker (1975) and Karttunen and Peters (1979) for examples that show that a counterfactual can be used if somebody other than the speaker holds the IF-clause to be false):

- (i) a. Since asbestos makes John sick, he will stop working in this building
- b. If asbestos makes John sick, he will stop working in this building
 (as an FC, e.g. in response to "Asbestos makes John sick")
- c. If asbestos makes John sick, he will leave the building
- d. If asbestos made John sick, he would leave the building.

Also, the FC IF-clause behaves as the first element in a V2 construction, forcing the verb to immediately follow it. Again, contrast (15b) with (33a), and (15a) with (33b):

(33)a. Als je zo ongelukkig bent moet je weggaan
'if you so unhappy are must you leave
'If you're so unhappy you should leave'

b. *Als je zo ongelukkig je moet weggaan

The IF-clauses of neither the RC nor the FC are preposable with VP fronting; (34) is as unacceptable as (19a):

(34) * leave this place if he is so unhappy though he should, he can still stay in touch with Mary

But unlike in the case of the RC, the FC can be stranded by VP fronting. Compare the unacceptable (19b) above with (35):

(35) leave this place though he should, if he's so unhappy, he can still stay in touch with Mary by correspondance

This is consistent with the idea that the IF-clause of the RC, unlike that of the FC, relates to the rest of the sentence as to a speech act and cannot appear inside it. This is also shown by the fact that an FC, unlike an RC,

can be embedded under non-speech act verbs. Compare the degraded (17b) with the acceptable (36):

(36) I believe that if Bill is so unhappy he should leave

In the previous section I mentioned that the role of the RC IF-clauses being about the speech act, makes it unsurprising that it is attached at the highest level of the sentence, even when it is in sentence-final position. This would follow if anything like the Performative Hypothesis is correct, since the clause that the RC IF-clause is the actual protasis of would be the highest one, i.e. the embedding performative prefix. This was witnessed by the lack of Binding Condition C effects (as in (19)). On the other hand, the sentence-final FC IF-clause does show Binding Condition C effects:

(37) *He₁ should leave if Bill₁ is so unhappy

The unacceptability of (37) and (34) in combination with the acceptability of (35) point towards the I-bar as the adjunction site of the sentence-final FC IF-clause. Following tests discussed in Chapter 1, one predicts that if the FC IF-clause is adjoined above the VP at the I-bar, it should always be interpreted outside the scope of negation, never inside it. This is borne out:

(38) You shouldn't remain quiet if you're so unhappy

Sentence (38) does not mean "you should remain quiet but not if you're unhappy". The interpretation of (38) clearly does not have the IF-clause

inside the scope of negation. Although the lack of ambiguity of (38) is consistent with everything so far argued for, I will suggest in a later section that it reflects a more important characteristic than attachment height.

So far then, it seems that we have three different attachment sites for sentence-final IF-clauses:

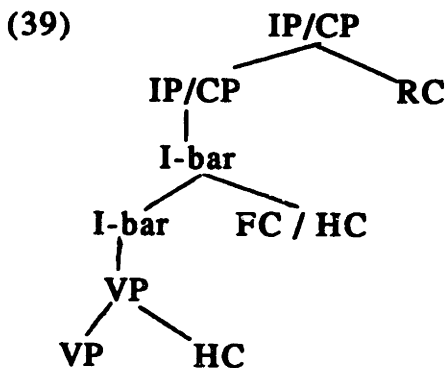

It is predicted, in other words, that when several IF-clauses appear in sentence-final position, they can only appear in the order HC-FC-RC. This is, in fact, the case:

(40) FC-RC, *RC-FC:

- a. You should leave if you're so unhappy if I may say so
- b. *You should leave if I may say so if you're so unhappy

(41) HC-FC, *FC-HC

- a. You should invite her to tea if you see her again if you like her so much

b. ? You should invite her to tea if you like her so much if you see her again

(from Haegeman and Wekker (1984), the judgment is also theirs; for the native speakers that I've asked (41b) is quite worse than a question mark⁷)

(42) HC-RC, *RC-HC

- a. Peter takes his dog out if it rains if you want to know**
- b. * Peter takes his dog out if you want to know if it rains**

(43) HC-FC-RC

You should invite her to tea if you see her again if you like her so much if I may say so

The pattern in (40)-(43) is predicted by (39). However, when the IF-clauses are sentence-initial their relative structural heights are the same (the linear order is, of course, the mirror image of the corresponding one in sentence-final position):

(44) *FC-RC, RC-FC:

- a. if I may say so if you're so unhappy you should leave**
- b. *if you're so unhappy if I may say so you should leave**

⁷ It's possible that this weaker judgment is due to the fact that both the HC and the FC can be attached to the I-bar. As a result, this sentence would not violate the absolute adjunction sites, but only the prescribed relative order between the HC and the FC, also operative in sentence-initial position as we shall see shortly.

(45) *HC-FC, FC-HC

- a. if you like her so much if you see her again you should invite her to tea
- b. *If you see her again if you like her so much you should invite her to tea

(46) *HC-RC, RC-HC

- a. If you want to know if it rains Peter takes his dog out
- b. * If it rains if you want to know Peter takes his dog out

(47) RC-FC-HC

If I may say so if you like her so much (then) if you see her again you should invite her to tea

Although they can appear only in the above orders, I have no reason to believe that in a sentence-initial position the different types of IF-clauses are adjoined to different positions. As far as I can tell, they are all attached to the IP (or CP). This means that a specific meaning for an IF-clause is associated with a specific attachment height of that IF-clause⁸. In sentence-final position this holds in absolute terms in the sense that there are different adjunction sites. In sentence-initial position this holds in relative terms in the sense that the different types of IF-clauses can appear only in a specific order with respect to each other. And as we have seen, the

⁸ I'll leave open the question of the direction of the causal relation (if there is one), i.e. the question of whether a different attachment height dictates a different meaning, or vice versa.

sentence-initial order reflects (in height, not in linear order) the order in the sentence-final position⁹.

2.2.3 *FC versus HC*

The discussion of the FC has so far yielded the adjunction site of its IF-clause when the latter is sentence-final, as well as the fact there is an associated presupposition that its content is held by somebody to be true. I have also mentioned that unlike the HC, the FC IF-clause does not specify the circumstances in which the consequent is true, but assumes that for somebody, the content of the IF-clause describes the actual circumstances. In this section I will deal with differences between the FC and the HC that result exactly from this difference. Recall that while an HC is paraphrasable as in (48), an FC is as in (49):

(48) In any circumstance in which Bill is so unhappy, Bill should leave

(49) In these circumstances, in which according to somebody's belief Bill is so unhappy, Bill should leave

We see that the HC IF-clause paraphrases as a restrictive relative clause, the FC IF-clause paraphrases as a non-restrictive/appositive relative.

⁹ According to David Pesetsky (p.c.) this is reminiscent of the order of WH-elements in Polish. In this language multiple WH-words are permitted in sentence-initial position, but their relative order is the same as when they are in situ.

We will see, in fact, that many of the differences between an HC and an FC replicate the differences between restricting and non-restricting (appositive) relative clauses.

According to Emonds (1979) and references cited there, the following are points at which restrictive relative clauses differ from appositives. The replication of these differences should be seen as a metaphor, since (both kinds of) relative clauses are very different syntactically from (both kinds of) conditionals.

(50) The appositive clause is presupposed. The restrictive relative denotes a property and is therefore neither asserted nor presupposed.

The second clause of (50) holds for HCs versus FCs, since, as we have already seen the IF-clause of the HC, but not of the FC, specifies which conditions the consequent can be predicated of, or is true in. We have also seen that the first clause of (50) describes the difference between the FC and the HC IF-clause. That is, it holds to the extent that it holds of appositive relative clauses. There are several notions of presupposition in the literature and although it is said by Emonds and others (Karttunen (n.d.), Levinson (1983)) that the truth of appositives is presupposed, it is hard to make this precise. One intuitive notion that is often applied, is that the content of the appositive is known by the hearer. But the use of "by the way" in (51) indicates exactly that the truth of the appositive is not presupposed by the hearer, rather is intended as a parenthetical information bit:

(51) I invited John, who by the way is my favourite cousin

It seems, then, that counting the notion of presupposition with respect to the hearer's prior knowledge does not define appositives as presupposed. On the other hand, if we were to define presupposition as being known by the speaker, we wouldn't be accomplishing much, as this would describe any assertion made. Recall that there was a not altogether different problem with the FC IF-clause. It wasn't clear by whom and to what extent the FC IF-clause was presupposed, although it was clear that somebody other than the speaker must hold it to be true.

There is, however, another test for presuppositional status and probably the most widely used one. This is constancy under negation, and with this test, appositive relatives do, in fact, come out as being presupposed. Both (51) above and its negation, (52), entail that John is my favourite cousin:

(52) I didn't invite John, who is my favourite cousin

The same point holds for the FC IF-clause. We have seen that the latter is always understood as having scope over negation, as was discussed in relation to the unambiguous (38), repeated below:

(38) You shouldn't remain quiet if you're so unhappy

Earlier, it was pointed out that the lack of ambiguity of (37) is consistent with the arguments that show that the FC IF-clause is attached above negation. However, if negative predicates like the ones in (51) are used, the sentence is still unambiguous:

(53) I disagree/It's not the case that he should remain quiet if he is so miserable

I disagree/It's not the case that if he is so miserable he should remain quiet

a. If he is so miserable he should fight back.

b. # He should remain quiet if he is[^] happy .

As is obvious from the contrast in (53), even if negation is given widest scope, the reading where the IF-clause is understood as being negated is still missing. So both (38) and (53) can be taken to show that the FC IF-clause remains unaffected by negation. In other words, it isn't clear what the correct notion of presupposition is that would make (50) meaningful. However, if the relevant test is constancy under negation, then the FC IF-clause comes out as presupposed. Irene Heim (p.c.) pointed out that the fact that an FC IF-clause is not affected by matrix negation may be one more instance of the more case of it not being able to associate with focus. The present cases under discussion would be association with negation, but the same holds for association with elements like only. The following sentence is ungrammatical as an FC, that is if somebody believes p, (54a) cannot be interpreted as (54b) (underlining indicates association with only):

(54) a. *She only should leave if she is so unhappy

b. $\forall p$ [[p ≠ she is unhappy] → ~[she should leave if p]]

Some more differences between appositives and restrictives, according to Emonds (1979) are the following:

(55) Unlike the restrictive relative, the appositive must be surrounded by intonational breaks (indicated by underlining)¹⁰:

- a. John, who is my favourite cousin, is sick with the flu
- b. *The man who is my favourite cousin is sick with the flu
- c. You should leave, if you're so unhappy
- d. *Peter takes the dog out if it rains

(56) The appositive must follow the restrictive clause

- a. *The children, who were charming, that you brought home got sick
- b. The children that you brought, who were charming, got sick

We have already seen in (41) and (45) above that (56) holds for the FC and the HC.

¹⁰ From now on I will adhere to the convention of putting an appositive clause between commas. This notation should be kept in mind especially in the cases where the head NP is a definite NP like the man, which can be modified by an appositive as well as by a restrictive clause.

(57) Restrictives but not appositives can move away from the element they modify¹¹:

a. Some men appeared at the door that Mary had been insulting

**b. *John and Bill appeared at the door, who Mary had been
insulting**

c. It is if I drink too much wine that I get dizzy

d. *It is if you like her so much that you should invite her

(from Haegeman and Wekker (1984))

(on the lower construal for the IF-clause:)

e. If it rains Mary thinks that Peter takes the dog out

f. *If he's so unhappy Mary thinks that he should leave

(58) No binding phenomena into appositives.

a. Every boy₁ saw the teacher who hit him₁ walk away

b. *Every boy₁ saw John, who hit him₁, walk away

c. Every boy₁ yells at Bill if he₁ is hungry

d. *Every boy₁ should leave if he₁ is so unhappy

¹¹ Again, it is not intended that the movement away from the element they modify is necessarily of the same type. For example, extraposition is involved in (57a,b) and topicalization in (57e,f), and maybe an operator in (57c,d).

The question arises as to whether the pattern shown by (50)-(58) is merely the result of the comparative height of attachment of the IF-clause, as represented in (39), or reflects a larger scale difference between restrictive and non-restrictive modification, the difference in attachment sites being one of many side-effects. According to Emonds (1979), Stuurman (1983), Safir (1986) and others, the answer to this question (with respect to relative clauses) is that the differences between restrictives and appositives can be accounted for if an appositive is a complete whole by itself in the semantic sense, i.e. a proposition with a truth-value, which is independent from that of the matrix clause. In turn, the matrix sentence containing an appositive is a complete proposition without the appositive, while a sentence containing a restrictive relative is not a proposition without it. This intuition is what underlies the thesis that appositives are main clauses that get grafted into the sentence at some late point. In effect, the appositive enters the sentence too late to interact with it syntactically.

I think that this roughly characterizes the difference between FCs and HCs as well. The pattern in (50) can be attributed to attachment height, as represented in (39). But the ungrammaticality of (37) (repeated below) shows that (58d) cannot be attributed to height of attachment, since the matrix subject c-commands the sentence-final IF-clause:

(37) *He₁ should leave, if Bill₁ is so unhappy

Also, if height of attachment were the only difference between FCs and HCs, there shouldn't be any difference in the licensing of parasitic gaps. But this is not so; parasitic gaps are possible in HCs but not in FCs:

- (59) a. Who should she invite if she sees again?
 b. *Who should she invite if she likes so much?¹²
 c. Bill, who she should invite if she sees again, ...
 d. *Bill, who she should invite if she likes so much, ...

The point is that the anti-c-command requirement between the parasitic gap and the licensing variable is satisfied in a sentence like (59b), no matter what the attachment height of the IF-clause is. So the contrast in (59) cannot be attributed to the difference in adjunction height. On the other hand, if we extend the general spirit of Emonds (1979) for relative clauses to conditionals, we can account for (48)-(58), as well as for (59). Since the appositive (relative clause or IF-clause) starts out as an independent sentence, it cannot have any grammatical dependencies that are satisfied outside it. In other words, the appositive cannot contain any variable, trace, anaphor etc whose antecedent is not contained in the appositive itself ¹³.

¹² Sentence (59b) is also degraded with a pronoun instead of the parasitic gap:

- (i) *Who₁ should she invite if she likes him₁ so much

This is due to an effect already described, namely the impossibility of bound variables inside the FC IF-clause.

¹³ This does not, however, account for the fact that appositives are attached higher than restrictive modifiers. We've already seen that this is the case for conditionals and relative clauses (and the same holds for adjectives: in prenominal position an appositive adjective must precede a restrictive adjective).

Whatever the exact answer to this is, it is the nature of appositives to talk about fully described referents and there are several metaphors that describe this situation. For example one could say that the appositive can never be lower than the restrictive because for the latter to be reached compositionally, so to speak (i.e. cyclically, bottom-up), the former would have to be included forcibly. In other words, if (ia) rather than (ib) were the case,

We saw in (37) above that Binding Condition C is operative in an FC.

It also is in an appositive relative clause:

(60) *Bill₁/*he₁ told Sue, who had met Bill₁ in May, that John is stupid¹⁴

There are in principle two possible explanations for this. One might say that Binding Condition C does not regulate a grammatical dependency, but is a prohibitive condition, which should apply at all levels. In fact, one

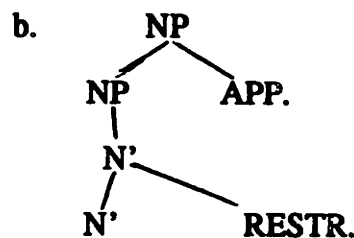
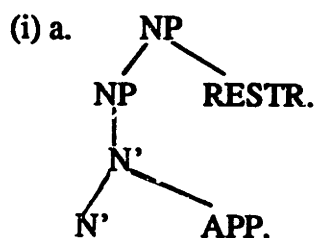

then in order for RESTR to be calculated in determining the reference of the NP, one would be forced to calculate APP in as well, since general principles of compositionality would not permit ignoring it. Another way to think about this is that if the appositive is grafted into the sentence at some late stage, it would not be able to enter a closed argument like the NP, which would include everything that determines its reference (i.e. restrictive modifiers). In other words, there is a certain domain in which everything is included in calculating the semantic value of a constituent, eg an NP, and the appositive cannot enter it. Or conversely, if a modifier is not inside that domain, it is not calculated into the semantic value, i.e. it is understood as an appositive.

As I said, these are just metaphors, and even as such they are incomplete, given that one might argue that they determine the relative order of modifiers, not absolute adjunction sites. To argue for the latter, one would have to say that an appositive relative, for example, must always be higher than the NP it modifies so that it is not calculated into its reference. Although this excludes all points below a certain height, it does not dictate any particular one above it, i.e. it doesn't say why the appositive should be adjoined to the NP rather than at any point higher. The answer to this in turn might be that if it were higher, it would interfere with compositionality at another point in the tree. These two prohibitions (one against containment inside the NP and one against adjunction above it) might conspire to dictate adjunction at the NP level as the only possible one.

If we have a better understanding of the principles that regulate the position of appositive and restrictive modifiers with respect to the element they modify, we will have a better understanding of the position and nature of the element that IF-clauses are restrictive or appositive modifiers of.

¹⁴ As with other similar sentences, the sentence improves if there is a discourse antecedent for the pronoun.

could follow the spirit of Safir (1986) and try to argue that Binding Condition C holds at a level *after* the appositive is attached to the main sentence. Safir argues that certain relations (like the one in bound variable anaphora) should be established by LF and also that there is a level LF', after LF, at which the appositive relative enters the main sentence.

Within Safir's framework one could make a case for Binding Condition C holding at LF'. Take a sentence like (61a) on the reading where John, he and who are understood as referring to the same person. Following the mechanisms that Safir proposes, one could say (61a) would be indexed as in (61b) at LF, and as in (61c) at LF' :

- (61) a. *John, who he washes, is sick
 b. LF: John₁, who₂ he₁ washes EC₂, is sick
 c. LF': John₁, who₁ he₁ washes EC₁, is sick

Safir argues that at LF, the pronoun contained in the appositive relative clause can be coindexed with the relative head, but the relative operator isn't coindexed with it because the appositive hasn't yet attached to the sentence. At LF', however, reindexing takes place and the relative operator must be coindexed with the relative head. Looking at the LF representation in (61b), we see that there is no Binding theory violation. But at the LF' representation (61c), Binding Condition C is violated, since the variable/EC, which is subject to Binding Condition C, is illicitly bound by he in the domain of its operator who. Within an account such as Safir's then, it is possible to account for the ungrammaticality of (60) and (37) without abandoning the position that grammatical dependencies are impossible in the same environment. This conflict is resolved if one

adheres to the position that grammatical dependencies must be established by LF, while Binding Condition C is still operative at LF' after the appositive has attached to the main sentence.

The second way to account for (60) and (37) is to attribute their ungrammaticality not to an intrasentential factor, like Binding Condition C, but to whatever rules out (62), adapted from Lasnik (1986), although the judgment of a '?' is too weak for the native speakers I asked¹⁵:

(62) ?He₁/?John₁ walked in. Then John₁ sat down.

It is possible to distinguish between this and Safir's account for the behaviour of R-expressions inside appositives by looking at epithets. According to Lasnik (1986), epithets, which are also subject to Binding Condition C, are better than names in such environments:

(63) John walked in. Then the idiot sat down.

According to Lasnik, the contrast between (62) and (63) is due to the partly pronominal status of epithets. Now let us consider what happens when we replace the names in the examples we have used with epithets. Like proper names, epithets are not permitted in restrictive modifiers:

(64)* Bill₁ told the man that had hit the poor slob₁ on Tuesday that Mary wanted her money back

¹⁵ Lasnik (1986) attributes the status of (62) to a Binding Condition C violation, but I will use this term to refer to the definition of Chomsky (1981), where the domain of this Condition is the sentence.

(65)*Peter₁ yells at Bill if the poor slob₁ is hungry

But they are permitted in appositives:

(66) Bill₁ told John, who had hit the poor slob₁ on Tuesday, that Mary wanted her money back

(67) Peter₁ should leave, if the poor slob₁ is really so unhappy (as an FC)

Clearly, (66) is better than (60) and (67) better than (37). This contrast might give some advantage to the account that attributes the ungrammaticality of (60) and (37) to whatever rules out (62) over an account like Safir's. Whatever the exact ramifications of the two accounts, however, it is possible to maintain the position that there can be no grammatical dependencies inside appositive relatives and FCs, without considering the presence of Binding Condition C effects as a counterexample¹⁶.

Finally, it is worth pointing out that the fact that the contrast between (62) and (63) is replicated by the contrast between (66) and (67) is consistent with the position that appositives relate to the main sentence as an independent sentence themselves.

¹⁶ If we substitute pronouns for the subjects in (66) and (67), the sentences are bad once again:

(i) *He₁ told John, who had hit the poor slob₁ on Tuesday that Mary wanted her money back

(ii) *He₁ should leave, if the poor slob₁ is so unhappy

But if we give a discourse antecedent to the pronouns, the sentences become good again, showing that the ungrammaticality of (i) and (ii) is due to the pronoun trying to get the epithet as an antecedent.

2.2.4 *BECAUSE- and SINCE-clauses*

In Chapter 1 there was a brief reference to causal since. This word is largely treated as synonymous with because. In other words, (68a) is supposed to mean the same as (68b):

- (68) a. I visited John because he is in bed with the flu
b. I visited John since he is in bed with the flu

We will see, however, that clauses introduced by because and since¹⁷ behave differently syntactically. Their differences are similar to those between an FC (and an appositive relative) and an HC (and restrictive relative) in that a SINCE-clause, unlike a BECAUSE clause is opaque to syntactic operations. Another difference that we will see exists between a SINCE-clause and a BECAUSE-clause is that the SINCE-clause behaves like and is interpreted as presupposed material. We saw that there was a similar difference between the FC IF-clause and the HC IF-clause. But as we have also seen, a SINCE-clause is understood as being believed by the speaker, while this is not possible for the content of the FC IF-clause, which must be believed by the hearer or a third party. In other words, it is not appropriate to say that both a SINCE-clause and an FC IF-clause are presupposed, without qualifying it further. One could respond to this by arguing that presupposition is an indexical notion and that all that is

¹⁷ Clauses introduced by given that and as behave like clauses introduced by since in the relevant respects.

necessary is that a clause be presupposed by somebody, to behave like an opaque domain syntactically. Such a response would choose that notion of presupposition in which the presupposed material behaves as background information to the main assertion¹⁸. This would also capture the intuition that a presupposed clause is an assertion made on the side, as was discussed in a previous section. Since a presupposed clause is the object of somebody's belief, it must be a proposition and not an open sentence. This would explain why a presupposed clause is opaque syntactically: if it had any external dependencies it would not be a proposition in itself. It also explains why the object of whose belief they are (speaker, hearer or third party) is not directly relevant. All that is relevant is that in order to be the object of *somebody's* belief they have to satisfy the requirement of being a complete proposition in themselves. This line of reasoning can also explain why presupposed material remains constant under negation. Since it is not part of the main assertion, the presupposed clause will not be affected by the negation contained in it. This is expected since these clauses are independent propositions whose truth-value is not dependent on the matrix clause (which in turn is also not dependent upon them for its truth-value). Moreover, being affected by matrix negation would amount to breaking the syntactic barrier that separates the appositive from the main clause.

In the previous section I mentioned the suggestion of Emonds (1979) and others that an appositive starts out as an independent sentence that attaches to the main sentence too late to have any grammatical dependencies

¹⁸ In this way, we can see why an appositive "feels like" presupposed material. From the fact that the speaker uses the appositive as background information the hearer can infer that the speaker holds its content to be true. This would mean that it isn't correct to say that the truth of the presupposed material is inferred by the hearer. All that is inferred is that the presupposed material is believed by the speaker.

satisfied outside it. Safir (1986) argued that certain relationships have to be established by LF and since the appositive attaches to the main sentence at LF' it cannot participate in such relationships. The suggestion that any presupposed clause must be a proposition in itself because it is the object of someone's belief and the Emonds/Safir position that an appositive attaches to the sentence too late to enter grammatical dependencies are obviously two sides of the same coin¹⁹.

In the remainder of this section I will first show that SINCE-clauses, unlike BECAUSE-clauses, do not permit external dependencies. Second, I will show that SINCE-clauses, unlike BECAUSE-clauses are not affected by negation in the main sentence. Constancy under negation is used as a diagnostic for presuppositionality, but since I am using the notion of presupposition in the vague sense of background information, I will use some other ways to test for this.

First of all, a BECAUSE-clause, but not a SINCE-clause, permits bound variables in it:

- (69) a. Who₁ did you hire because Mary recommended him₁?
b. *Who₁ did you hire since Mary recommended him₁?

- (70) a. Every boy₁ had to go to bed because he₁ had to be up by 5
b. *Every boy₁ had to go to bed since he₁ had to be up by 5

¹⁹ However, once we are forced to keep the presupposed clause as an independent proposition, one could ask whether we still need to resort to an LF or any account of delayed attachment to the main sentence. If the syntactic opacity were broken and the clause were not a proposition anymore, it would not be possible to interpret it as the object of someone's belief. Sometimes this will result in a mere difference of interpretation, sometimes in ungrammaticality.

That (69)-(70) are not due to lack of c-command, in turn due to attachment height, can be seen from the fact that Condition C is still operative:

- (71) a. *He₁ went home because Bill₁ wasn't feeling well
b. *He₁ went home since Bill₁ wasn't feeling well

Parasitic gaps are permitted in a BECAUSE-clause, but not in a SINCE-clause:

- (72) a. Who did she invite to the party because she likes?
b. *Who did she invite to the party since she likes?

The contrast in (72) also confirms that (69)-(70) cannot be attributed to mere height of adjunction and the ensuing lack of c-command, since whatever the height of attachment is, the anti c-command requirement will be satisfied.

One could argue that along with the pattern in (69)-(70) (and the corresponding one for FCs, mentioned in the previous section) goes the impossibility of modifying these clauses by elements like just, only or even (from Quirk et al (1985)):

- (73) a. John left home only/just because he was short of money
b. *John left home only/just since he was short of money

And while an HC IF-clause can be modified by these elements, an FC IF-clause cannot:

- (74) a. Peter takes his dog out only/even/just if it rains
 b. A: I'm very unhappy here
 B: * You should leave only if you're so unhappy²⁰

If these elements make their associates quantificational, this would force them to interact syntactically with the main sentence and this is not permitted.

Similarly we see that SINCE-clauses cannot be focused:

- (75) a. It is because he was poor that he had to leave home
 b. *It is since he was poor that he had to leave home

Clefting SINCE-clauses would break their syntactic opacity with respect to the main sentence, whatever the account of clefting. We have already seen that the same contrast holds between HCs and FCs.

Unlike a BECAUSE-clause, a SINCE-clause can never be an answer to a question.

- (76) A: Why did John leave?
 B: a. Because he wasn't feeling well
 b. #*Since he wasn't feeling well

Again, one cannot interpret why as standing for a SINCE-clause, because interaction with the main CP node would break the syntactic barrier. In

²⁰ Although I have found speakers to differ on this, even seems better than only in (74B).

section 2.2.1 we saw that the content of the FC IF-clause, unlike the HC IF-clause, cannot be questioned.

The same point is made by the following:

- (77) a. Did John leave because he was sick or because he was tired?
b. *Did John leave since he was sick or since he was tired?

Alternative questions like the ones in (77) involve a marker for the scope of or, as argued by Larson (1985) and others. For these sentences to be interpreted as matrix questions the scope marker of or must reach the matrix CP. But by doing so, the opacity between the SINCE-clauses and the main sentence would be violated, leading to ungrammaticality.

We see, then, that SINCE-clause, unlike BECAUSE-clauses are opaque domains for grammatical operations that are satisfied outside them. Next I will show that SINCE-clauses, unlike BECAUSE-clauses are unaffected by matrix negation.

First of all, as mentioned, the content of the SINCE-clause cannot be associated with negation, unlike the content of the BECAUSE-clause:

- (78) a. It is not the case that John left because he was sick. He left because he has to be home by 9 p.m.
b. #*It is not the case that John left since he was sick. He left since he has to be home by 9 p.m.

In other words, a SINCE-clause cannot be associated negation contained in the matrix sentence²¹. Contrast (79a) whose ambiguity was discussed in Chapter 1, to the unambiguous (79b):

- (79) a. I didn't leave because I was sick
b. I didn't leave since I was sick

(79b) only has the interpretation according to which I did not leave and the reason was that I was sick.

For the same reason, a SINCE-clause cannot contain an NPI licensed by matrix negation. Compare (80a) to the ungrammatical (80b):

- (80) a. He didn't leave because he had to meet anybody (but because he was late)
b. #He didn't leave since he had to meet anybody

The same holds for NPI licensing by higher negative predicates:

- (81) a. I doubt that he left because anybody came
b. #I doubt that he left since anybody came

The contrast in (81), (80), (79) and (78) show exactly the same thing: a SINCE-clause is never understood as being affected by matrix negation. Moreover, the contrasts in (78) and (81) show that this cannot be due to the

²¹ Recall the relevant discussion for FC IF-clauses where it was pointed out that being negated is an instance of association with focus, and not just a matter of being in the scope, i.e. c-command domain of a negative element.

SINCE-clause being attached above negation since in these sentences the negative element is definitely higher than the **SINCE**-clause.

Related to the above, is the fact that the content of the **SINCE**-clause cannot be retracted:

- (82) a. He didn't leave because he was sick. In fact, he wasn't sick
b. He didn't leave since he was sick. #In fact, he wasn't sick²².

Moreover, a sentence like (83a) is ambiguous between (83b) and (83c) (thanks to Howard Lasnik for these examples):

- (83) a. Noone left because Mary was singing
b. Because Mary was singing, everybody stayed
c. People might have left, but for reasons other than Mary's singing

²² The complement of Factive verbs has also been said to be presupposed (Kiparsky & Kiparsky (1970)). However, most of the tests applied here behave differently in these environments. For example, factive complements permit external dependencies:

- (i) Every boy₁ found out that he₁ has poison ivy

Factive complements are said to remain constant under negation. However, it has been pointed out by many that a factive complement can be retracted. Contrast (82b) to (ii):

- (ii) I didn't regret going there because, in fact, I never went there

Another important difference between factive complements and appositive relatives, FCs or **SINCE**-clauses is that the former cannot enter the sentence too late or else the selection requirements of the matrix verb will not be satisfied.

I will leave to others a more precise discussion of factive complements and the questions of in what sense and to what degree they can be said to be presupposed.

However a sentence like (84) is unambiguous, showing that, whatever the account of such sentences, SINCE-clauses do not interact scopally with a negative element in the main clause:

(84) Noone left since Mary was singing

Constancy under negation is a traditional test for presuppositionality. But another way to test for presupposed material is embedding under a predicate like I just found out that. The part of the sentence that can be understood as being the recently acquired knowledge is the assertion; the rest is the presupposition. Applying this test will show that the SINCE-clause is presupposed:

(85) I knew that John had left. But I just found out that he left because he was sick.

(86) I knew that John had left. #But I just found out that he left since he was sick

Another similarity between SINCE-clauses and FCs is that they are adjoined at the I-bar²³, as witnessed by the fact that they cannot be fronted with the VF, while BECAUSE-clauses and HC IF-clauses can be, as we have seen in previous sections:

²³ The IP (or higher) cannot be the adjunction site since the matrix subject c-commands the SINCE-clause (see Binding Condition C effects above).

(87) a. *Leave the party early since he has to be home by 9 p.m. though John did, Bill will still find something to complain about.

b. Leave the party early though John did, since he has to be home by 9 p.m., Bill will still find something to complain about.

Although the contrast in (87) is consistent with the I-bar as the appropriate attachment site, there are some other data that show that this is not a complete answer. Consider the following sentences which contain VP deletion:

(88) a. John said that he left because he was sick and Bill did too

b. John said that he left since he was sick and Bill did too

If both SINCE-clauses and FCs are attached at the I-bar, it is possible that this is dictated by one of two constraints:

(89) a. all non-restrictive adjuncts must be outside the VP and all restrictive adjuncts must be inside it;

or

b. all non-restrictive adjuncts must be outside the VP, while restrictive ones can be either inside or outside it.

I will not address this choice further here.

Summarizing this section, I have argued that clauses that are presupposed in the sense that they are background information, like FC IF-clauses and SINCE-clauses are independent statements that are made on the side²⁴. Since they are not part of the main assertion, they will not be affected by the negation contained in it. Since they are independent statements, they have to be closed propositions and therefore they do not permit any external dependencies, since these would make them open sentences.

2.2.6 Back to the FCs

In section 2.2.4 I mentioned that referential dependencies are just one type of dependency not permitted in an FC. Dependencies of the inflectional system are another one. In this section I will concentrate on the latter type. In doing so I follow an intuition of Haegeman and Wekker (1984) and for this reason I will first give a short overview of their paper.

The main concern of Haegeman and Wekker (1984) is to explain the restricted use of futurate will in IF-clauses²⁵:

²⁴ This means that the near synonymy between since and because is only apparent. A better paraphrase for since is given that (more explicitly presuppositional). It seems to me, in fact, that the latter reading of since (which makes it close to because) is the result of a conversational implicature, as is the paraphrasability of the FC IF-clause by a SINCE-clause. But I will not pursue this intuition here.

²⁵ I have found some variation on this among native speakers, but according to grammars and probably the majority of linguistic literature, the only type of will permitted inside IF-clauses is the one denoting disposition or volition. The pervasive descriptive line is that the future inside an IF-clause is indicated by the simple present tense. The same restrictions are said to hold for counterfactual would, but since I am not discussing counterfactuals at all, I will not be mentioning would either.

- (90) a. *If it will rain tomorrow, the match will be cancelled
 b. If it will rain tomorrow, we might as well cancel the match now

H & W divide conditional IF-clauses into two types: the peripheral ones and the central ones. And they also argue that the two types of IF-clauses differ in adjunction height. The adjunction sites they propose are shown in (91):

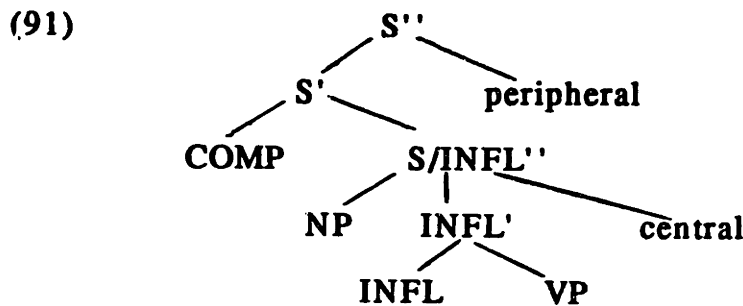

H & W's position is that futurate will can appear in peripheral conditionals, but not in the central ones.

According to H & W, central IF-clauses do not permit will because they are in the scope of the matrix INFL; the future reading of the present tense contained in the central IF-clause is "assigned to it" by the matrix tense. On the other hand, the peripheral IF-clause is not in the scope of the matrix INFL. Therefore it cannot be assigned a future reading by the future contained in the matrix sentence. As a result, it can (or must, if that is the desired reading) contain a future marker of its own.

They remark that "peripheral conditionals are conditions on the relevance of an expression" and give (92) in a footnote (fn. 6) as an example of this:

(92) If you won't be with us for the late news, goodnight

We have already seen that this characterizes RCs (of which (92) is arguably an instance). However, judging from all their examples and the discussion in the main text, it seems that their peripheral IF-clauses correspond to the FCs in the present discussion and not the RCs. In fact, one of the examples used more often as an illustration of an FC within the present context, is taken from them:

(93) If you like her so much, you should invite her

We have seen that there are quite a few differences between RCs and FCs, such that it is not possible to collapse them into one category, as H & W do.

Another point where the present discussion differs from H&W's is in considering (94) rather than (93) as the structure representing the attachment sites of the different types of IF-clauses:

(94)

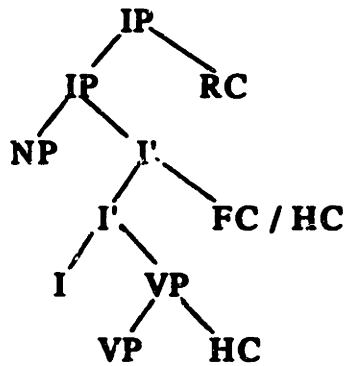

A final point about the account H&W propose for will inside IF-clauses is that it only deals with sentence-final IF-clauses. But in sentence-initial position, where all INFLs are outside the scope of the matrix INFL, we observe the same distribution of will. It cannot be argued that the relevant relation between matrix INFL and IF-clause INFL holds at LF after reconstruction, because of sentences like (95):

(95) If Peter₁ comes home, he₁ will tell us what happened

If the IF-clause in (95) reconstructed to a sentence-final position, the sentence would result in a Binding Condition C violation because Peter would be c-commanded by he. Since this is not the case, it is not possible to argue that the IF-clause enters the scope of matrix will after reconstruction. Yet, H&W would say that the futurity of the IF-clause is given by the matrix will.

Having said all this, I still think that their intuition that the permissibility of will is somehow related with a certain adjunction site of the IF-clause seems right and would like to propose a slight modification of their proposal.

First of all, although the impossibility of will inside an IF-clause is frequently discussed, it isn't clear that this claim is factually correct. Without claiming familiarity with the entire relevant literature, it appears that the following is the case, as long as the conditional is interpreted as an HC:

- (96) a. If the IF-clause is understood as chronologically preceding the consequent then only the consequent contains will.
b. If the IF-clause is understood as chronologically following the consequent then the IF-clause can contain will.

In other words, the HC IF-clause contains will only if it is understood as being future with respect to the consequent. An illustration of (96a) are the sentences in (97) and of (96b) the ones in (98):

- (97) a. If it (*will) rains we will get wet
b. If you (*will) invite me I will visit you

- (98) a. If it will make you happy I will visit you
b. If you will be alone on Christmas day, let us know now

(from Close (1980))

The pattern in (70) seems to capture roughly the distribution of will in IF-clauses (see Declerck (1984) for a large collection of data with will inside IF-clauses). It is possible that there are several exceptions to (96), but the FC IF-clause does seem to be one of them:

(99) A: John will arrive tonight with the 11:45 train

B: If he will arrive so late I will talk to him tomorrow

The sequence of tense phenomena, or whatever is responsible for the future reading of the present tense contained in an HC IF-clause, is undoubtedly a sort of grammatical dependency and, as we've seen, these are permissible only with HCs and not with FCs, which by their nature have to be propositions in themselves. By containing will, an IF-clause cannot enter this grammatical dependency. As a result, will is possible with an FC interpretation, as we saw above). This is obviously not a function of the attachment height, although a certain attachment is dictated when the IF-clause is sentence-final, since an FC cannot appear inside the VP. Rather what seems to be the case is that the semantics of an IF-clause is correlated with the availability of will, as well as with adjunction site. As a result, there appears to be a correlation between the latter two elements. But neither of them is the cause of the other; they both result from the restrictive versus non-restrictive nature of the IF-clause.

I have argued in this section that Haegeman and Wekker are right in saying that the presence of will inside an IF-clause correlates with a certain attachment height of that IF-clause. However, I do not think they are right in saying that *only* an FC IF-clause can contain will.

2.2.7 Summary

In a previous section I claimed that conditionals are ambiguous between HCs and FCs (RCs are much easier to identify) but that there are

some elements that disambiguate between them because they are compatible with only the one or the other. A summary of such differences (along with some that are compatible with more than one type) is found in the table in (100):

(100)	HC	FC	RC
IF-clause presupposed	-	+	-
grammatical dependencies	+	-	?
compatibility with <u>then</u>	+	+	-
interacts with V2	+	+	-
adjunction sites	I-bar/VP	I-bar	IP/CP
modification	restr.	non-restr.	restr.

This table obviously does not contain all the characteristics that we've discussed; it merely serves for easy reference. And (equally obviously) the points of differences are not disjoint; I have already discussed how the first and second rows might be related, or the first and last.

Finally, I would like to close this chapter with one more difference between the several types of conditionals without expanding on it further

It is a much discussed property of conditionals that Negative Polarity Items (NPIs) are licensed in the IF-clause. This is true of HCs (101) and RCs (102), but not of FCs (103)²⁶:

²⁶ In order to ensure an FC reading, I have put elements in the IF-clause that are compatible only with the FC interpretation (will, ought to) or strongly suggest it (so, indeed).

- (101) a. If I see anybody on the street I get scared
 b. If you ever come to Boston look me up
 c. If John lifts a finger to help I'll be surprised
 d. If he bats an eyelash I'll be surprised
- (102) a. If you want anything to read, there are books on the table
 b. If anyone wants to know, my address is
 c. If you want to talk to anyone, the phone is over there
 d. If you ever want to visit me, my address is
- (103) a. *If he (indeed) lifted a finger to help you should pay him
 b. *If you're so mad at anybody you should show it
 c. *If he will lift a finger to help you should pay him
 d. *If Bill ought to lift a finger to help Sue will inform us

If we look at the table in (100) we see that the ability to carry NPIs is correlated with the restrictiveness property of the IF-clause and/or the lack of presupposition (or both, since the two are arguably related). In Iatridou (in preparation) I discuss some theories that have been proposed to explain the fact that NPIs can appear in IF-clauses and evaluate them with respect to their ability to account for the pattern in (101)-(103).

CHAPTER 3

THE SEMANTIC CONTRIBUTION OF 'THEN'

3.1.1

It is widely assumed that the appearance of then in a conditional is optional and that it contributes nothing to the meaning of the conditional as a whole. In other words, (1a) and (1b) are taken to be equivalent:

- (1) a. If John gets a good education, he'll get a job
b. If John gets a good education, then he'll get a job

This assumption is also widespread in logic (text)books. For example Quine (1982, p.54) says:

For a further example of the reduction of manifold idioms of ordinary language to uniformity in logical notations, consider the idiomatic variants of 'if-then':

if p then q, p only if q, q if p, q provided that p,
q in case p.

The notation ' $p \rightarrow q$ ', insofar as it may be admitted as a version of 'if p then q' at all, is a version at once of all those variants idioms."

On the other hand, Grice (1989) writes (p.63):

"In fact, there seem to me to be quite a number of different forms of statement each of which has a good right to the conditional, and a number of which are quite ordinary or humdrum, such as "if p,q," "if p then q," "unless p,q," and "supposing p, (then) q," together with an indefinite multitude of further forms. The two forms which the strong theorist most signally fails to distinguish are "if p,q" and "if p then q"; and the strong theorist, therefore, also fails to differentiate between two distinct philosophical these: (1) that the sense of "if p,q" is given by the material conditional, and (2) that the sense of "if p then q" is given by the material conditional. Thesis (1) seems to have a good chance of being correct, whereas thesis (2) seems to be plainly incorrect, since the meaning of "if p, then q" is little different from that of "if p, in that case q," a linguistic form which has a much closer connection with argument than would attach to the linguistic form in which the word "then" does not appear. We should be careful, therefore, not to allow ourselves to be convinced that the meaning of "if p,q" diverges from that of the corresponding material conditional by an argument which relies on a genuine but irrelevant difference between "if p then q" and the material conditional " $p \supset q$."

Grice, in other words, acknowledges that "if p,q" and "if p then q" are mistakenly confounded and cautions against the identification of the latter

with the material conditional¹. But he does not suggest any concrete difference between the two forms other than that "if p, then q" has "a much closer connection with argument" than "if p, q" does.

In this chapter I will try to make a specific proposal about the meaning of then, such that its presence is sometimes predicted to result in degraded sentences. More specifically, I would like to propose that because of then, a statement like (2a) carries the presupposition (2b) in addition to its assertion (2c)²:

- (2) a. statement= if p, then q
- b. presupposition= if $\sim p$ implies $\sim q$
- c. assertion = if p, q

The idea is the following: a conditional of the form "if p, q" does not say anything about cases in which $\sim p$ holds. In other words, the truth of (3a) says nothing about the truth of (3b). In fact, (3a) is perfectly compatible with (3c), which can be uttered immediately after (3a):

¹The question of whether a natural language conditional should be seen as material implication has been addressed by many. According to the material implication view, the truth of the consequent and the falsity of the antecedent are each sufficient to make the conditional true. This has been argued to give the wrong predictions for some natural language conditionals (Kratzer (1978), Heim (1989))

² This is a first approximation; later I will give a modification of (2b). That (2b) is a presupposition and not an entailment can be seen by embedding all the conditionals where then cannot appear (to be discussed shortly) under the negated matrix "It is not the case that ..." and observing that the sentence is still unacceptable. If (2b) were an entailment then the sentences that violate it would be false and their negation should be true.

- (3) a. If Quayle runs for president, the Republicans will lose
 b. If Quayle doesn't run, the Republicans will win
 c. In fact, if Quayle doesn't run for president, the
 Republicans will still lose

The presence of then presupposes (belief in the fact) that the negation of the antecedent implies the negation of the consequent. Take for example (4a)=(3a)+then); The negation of the antecedent is If Quayle doesn't run. If this sentence is compatible the negation of the consequent, i.e. imply the Republicans will not lose, then the presupposition of then is satisfied. In other words, if (4b)=(3b) is (believed to be) true, then the presupposition of then in (4a) is satisfied, and its presence is acceptable. But now imagine the case where the negation of the antecedent does not imply the negation of the consequent; imagine in other words that (4c)=(3c) is true. If it is believed that (4c) is true, then the presupposition of then in (4a) is not satisfied. This means that a speaker that believes (4c) cannot felicitously utter (4a):

- (4) a. If Quayle runs, then the Republicans will lose
 b. If Quayle doesn't run, the Republicans will win
 c. If Quayle doesn't run, the Republicans will lose

In other words, the difference between (3a) and (4a) is that while (3a) is compatible with both (3b)/(4b) and (3c)/(4c), (4a) is compatible only with (3b)/(4b). This means that (3c)/(4c) can be uttered immediately after (3a) but it cannot be uttered after (4c):

- (5) If Quayle runs, then the Republicans will lose. #In fact, if Quayle doesn't run, the Republicans will still lose.

However, the optionality of then in (3a)/(4a) and the suggested difference in meaning may be too subtle to convincingly argue for the proposal in (2). The best argument for (2) is the existence of cases where, for whatever reason, the presupposition of then (2b) cannot be satisfied and as a result then cannot appear, leading to contrasts much stronger than the one between (3a) and (4a). I will discuss some such cases in the next section.

3.1.2

As was mentioned in chapter 2, the relevance conditional (RC) is incompatible with then:

- (6) a. If you're thirsty (#then) there is a beer in the fridge
b. If I may say so (#then) John is looking good today

As discussed, the RC IF-clause states a condition under which the consequent can be uttered, and is not part of the assertion. What is asserted is that there is beer in the fridge and that John looks good. Therefore the speaker does not believe that if you're not thirsty there will be no beer in the fridge, or that if s/he is not permitted to speak, John will not look good. This means that (2b) cannot be satisfied and the fact that then cannot be used in the RC is predicted.

As was noted in Chapter 3, the FC, in contrast to the RC, does allow then:

- (7) A: Bill is very unhappy here
B: If he's so unhappy then he will leave

According to the present proposal about the presupposition of then, the acceptability of (7B) predicts that the negation of the antecedent will imply the negation of the consequent:

- (8) If Bill isn't unhappy, he will stay.

But now the following problem arises: the truth of the FC IF-clause is presupposed as being believed by someone, and negating its IF-clause, as in (8), ignores this. Instead of (8), then, we can have (9) to satisfy (2b):

- (9) If Bill weren't so unhappy he would stay

The presupposition of the antecedent in (9) is compatible with the presupposition of (7). This is advantageous in addition because the presence of so in (8) is unacceptable, and (8) and (7) cannot be uttered together, while (9) and (7) can:

- (10) A: Bill is very unhappy here
B: If he is so unhappy he will leave. #If he isn't (*so) unhappy, he will stay.

(11) A: Bill is very unhappy here

B: If he is so unhappy he will leave. If he weren't (so) unhappy, he would stay.

So it seems that the negated antecedent that will satisfy (2b) can be counterfactual. Returning to the case of the RC, we see that accepting a counterfactual negated antecedent will still not satisfy (2b). For example, the speaker of (6a) is definitely not committed to the truth of (12):

(12) If you weren't thirsty there wouldn't be a beer in the fridge

In other words, although the FC and the RC have in common that their antecedents are not part of the assertion, they differ with respect to their ability to take then, because in the case of the FC the negated (counterfactual) antecedent will satisfy (2b).

An IF-clause can contain a disjunction and the conditional can still contain then:

(13) If John is dead or seriously ill, then Mary will collect the insurance money

In other words, there is nothing inherently incompatible between a disjunction inside the antecedent and the appearance of then. Yet there are cases where then cannot appear:

- (14) a. If John is dead or alive, Bill will find him
b. #If John is dead or alive, then Bill find him

The oddness of (14b) is predicted under (2). The antecedent **p** (=John is dead or alive) exhausts the whole universe and there is no room left for $\sim p$, so to speak. This means that (2b) will not be satisfied. In other words, when the antecedent is necessarily true, (2b) can never be satisfied³.

A sentence like (15) proves the same point. In order to accept the presence of then one has to assume that there are more than just the two weather conditions under consideration:

(15) If it's wet or dry outside, then John will visit Mary

To have (15) be acceptable, one is forced to assume the additional existence of something like "misty" as a possible weather condition, *not* subsumed under "wet" or "dry". This would make it possible for $\sim p$ to exist and satisfy (2b). If the weather is exhaustively described by 'wet or dry', the appearance of then yields a degraded sentence.

A similar case is that of even if which is never compatible with then:

- (16) a. Even if John is drunk, Bill will vote for him
b. #Even if John is drunk then Bill will vote for him

³ From the point of view of material implication, an impossible proposition implies every proposition. In this case, this means that $\sim p$ ("It is not the case that John is dead or alive") implies $\sim q$, thereby satisfying (2b). Putting aside the question whether material implication adequately represents natural language conditionals, in section 3.1.4 I will suggest a modification that will solve this difficulty.

It has been argued that even if entails the consequent (Bennett (1982) and others)⁴. In other words, (10a) says more or less that Bill will support John no matter what. A conditional containing even if is similar to (14a) in the following way: in (14a) the antecedent exhausts the whole universe by containing a disjunction of the form "p or ~p". A conditional like (16a) with an antecedent of the form "even if" also exhausts the universe. (16a) can be paraphrased as (17):

(17) If John is drunk or not drunk, Bill will vote for him

The difference is that even if exhausts the universe scalarly (Horn (1969), Fauconnier (1975)). The use of even presupposes the existence of a scale of which the lowest point of expectation is the associate of even, in our case the IF-clause. In other words, that Bill would vote for John is more

⁴ When even is attached to a constituent, it can take as its associate that whole constituent or a subpart of it. The same holds for when they are attached to an IF-clause, as indicated by underlining:

- (i) a. Even if John ate the potatoes, Mary will be mad
- b. Even if John ate the potatoes, Mary will be mad
- c. Even if John ate the potatoes, Mary will be mad
- d. Even if John ate the potatoes, Mary will be mad

As Bennett (1982) and others have pointed out, the main difference in interpretation between (ia) and (ib,d) is that in the former the consequent is entailed, but in the latter it is not. Bennett calls cases like (ia) "introduced conditionals" because removal of even would also remove its associate, namely the entire IF-clause. In effect, (ia) asserts that Mary will be mad no matter what. Cases like (ib,d) he calls "standing conditionals" because after removing even there is still a conditional meaning. (ib,d) do not assert that Mary will be mad no matter what, but they specify the circumstances under which she will.

Throughout this section I will be referring to the reading of even if where the associate of even is the entire IF-clause, and not a constituent contained therein. In the cases where the associate of even is a constituent of the IF-clause, I have found the presence of then to vary from speaker to speaker. From the discussion in the main text, it will be obvious why the presence of then is expected to improve in the cases where the consequent is not entailed, i.e. in the cases where the associate of even is a constituent of the IF-clause.

expected in the case that John is sober, than in the case that John is drunk. This is conveyed by the fact that if John is drunk is the associate of even. But what is also conveyed is that Bill will vote for John under any circumstances. So in (14a) the antecedent exhausts the universe by the disjunction it contains. In (16a) the antecedent exhausts the universe through the scale associated with even (if) ⁵. In both cases there is no room for the existence of $\sim p$, and therefore (2b) cannot be satisfied, precluding the appearance of then in (16a).

So far we have seen that the proposal in (2) makes the right predictions: then can appear only when the negation of the antecedent will make the consequent false. Now let's look at one case that appears at first sight to be problematic for (2). This is the conditional with only if which also cannot contain then⁶:

⁵ There are other ways to scalarly exhaust the universe. For example:

- (i) If I were the richest linguist on earth, I (still) wouldn't be able to afford this house
- (ii) If he were the last man on earth, she wouldn't marry him

Superlatives (i) are endpoints of scales, as are pragmatically set extremes (ii) (Fauconnier (1975)). As argued in the main text, association with a scale that exhausts the whole universe does not leave room for the existence of an alternative antecedent to satisfy the presupposition of then. The prediction is, then, that then cannot appear in (i) and (ii). This is the case:

- (iii) #If I were the richest linguist on earth, then I wouldn't be able to afford this house
- (iv) #If he were the last man on earth, then she wouldn't marry him

In fact, no concessive conditional permits then, because, as is the case for even if, the assertion is that the consequent is true no matter what. As a result, there is no possible alternative antecedent to imply the negation of the consequent. (See Konig (1986) and references therein, for discussions of concessive conditionals).

⁶ Not allowing then is a similarity between even if and only if conditionals. Some differences are the following:

(i)
EVEN IF

ONLY IF

(a) V2 in consequent	√ (obligatory)	*
(b) topicalization in consequent	*	√
(c) clefting in consequent	*	√
(d) NEG inversion in consequent	*	√
(e) imperative in consequent	*	√
(f) WH-question in consequent	*	√

Generalization (ia) is shown in (ii), (ib) in (iii), (ic) in (iv), (id) in (v), (ie) in (vi), and (iif) in (vii):

- (ii) a. Only if John comes will I come
b. *Only if John comes I will come
c. Even if John comes I will come
- (iii) a. *Only if Mary quits, this man I will hire
b. Even if Mary quits, this man I will hire
- (iv) a. *Only if they make me, it's this man that I'll marry
b. Even if they forbid it, it's this man that I'll marry
- (v) a. *Only if they oblige me, not a thing will I eat
b. Even if they oblige me, not a thing will I eat
- (vi) a. *Only if he calls, wake me!
b. Even if he calls, wake me!
- (vii) a. *Only if it rains, what will we eat?
b. Even if it rains, what will we eat?

Except for the contrast in (v), the rest of the differences hold only when the IF-clauses are in sentence-initial position. When the IF-clauses are sentence-final, topicalization, clefting, imperatives, and WH-questions are possible in both consequents and there is no V2 in only if consequents. We can explain this pattern if we take the even if IF-clause to stand where the sentence-initial HC IF-clause does (namely adjoined to the IP or CP) but the only if IF-clause to stand in the [SPEC,CP]. This positioning of the only if IF-clause, in combination with the fact that like other elements causing NEG-inversion, the only if IF-clause must be immediately followed by the verb, explains why there is literally no space for other CP phenomena. This also makes the correct prediction that while extraction from an even if consequent is possible, it is not from an only if consequent, since the [SPEC,CP] is filled up by the only if IF-clause, blocking long-distance extraction:

- (viii) a. How₁ did every girl say that even if her father comes she will fix the car EC₁?
b. *How₁ did every girl say that only if her father comes will she fix the car EC₁?

If there is no inversion in the embedded clause in (viii b), the sentence is much better:

- (18) a. #Only if it's sunny then will I visit you
 b. #Only if it's sunny then I will visit you

The problem that only if poses for the proposal in (2) is that not only is it compatible with (2b), it satisfies a condition stronger than (2b). Only if

-
- (ix) (%) How₁ did every girl say that only if her father comes she will fix the car EC₁?

Since there is no NEG-inversion in the embedded clause in (ix), the only if IF-clause can be assumed not to stand in the [SPEC, CP], which is therefore left open for elements to move through it. Sentence (ix) has the status of an only if conditional whose sentence-initial IF-clause has not caused V2:

- (x) (%) Only if her father comes she will fix the car

There are speakers for whom (x) is acceptable, and for those (ix) is as well.

The contrast in (v) between only if and even if conditionals remains even when the IF-clauses are sentence-final:

- (xi) a. *Not a thing will I eat only if you oblige me
 b. Not a thing will I eat even if you oblige me

This is due to whatever blocks in a sentence the presence of multiple elements that would each independently cause NEG-inversion:

- (xii) a. *Under no circumstance will I eat not a thing
 b. *Not a thing will I eat under no circumstances

Another difference was observed by Baker (1970b), who noted that the protasis of an even if conditional cannot contain an NPI (the following are not the actual examples that Baker provides; those contain complications irrelevant for the present case):

- (xiii) a. #Even if anybody begs me to go out, I'm staying home
 b. #Even if he visits anybody, John feels lonely
 c. #Even if you ever need company, don't look me up!

The above sentences should be contrasted with those in (xiv), which show that only if IF-clauses *can* contain NPIs:

- (xiv) a. Only if anybody is sick do they wake me up
 b. Only if he visits anybody does John behave well
 c. Only if you are ever in dire need of company should you invite John

I discuss this difference in Iatridou (in prep.)

asserts exactly that *any* antecedent other than the actual one will make the consequent false (just as (2b) requires):

(19) Only if it's sunny will I come. If it isn't sunny I won't come

Since (19) obviously satisfies (2b), we cannot use in the present case the arguments we used for the other cases that do not permit then.

Without choosing among them, I will outline three proposals to account for the fact that only if does not take then. First of all, one might argue that the oddness of the sentences in (18) is due to then blocking a syntactic requirement of only if. Only if in English belongs to the class of "NEG-inverters":

- (20) a. Never have I seen such good scores
- b. Under no circumstances will John visit his ex-wife
- c. Only if it's sunny will I visit you

It has been argued that NEG-inverters stand in the specifier of a CP to whose head the verb must move:

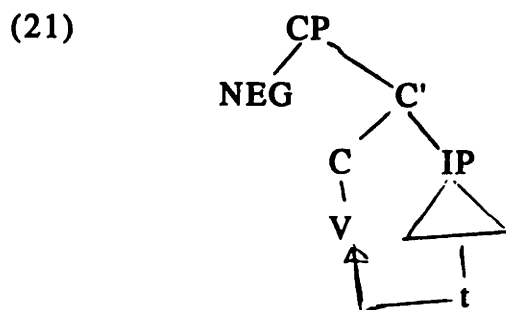

It is possible, therefore, that the presence of then blocks V-movement. This is not implausible, since, as we will see in the next chapter, then blocks movement of other elements from below it. But if this (English-particular) account of the oddness of (18) is correct, the prediction is that in languages without NEG-inversion only if should be compatible with then. So far I have found no language that permits then with only if, even if the language has no NEG-inversion. In Modern Greek, for example, V-movement with fronted negative elements is not obligatory⁷:

(22) Se kamia periptosi o Kostas dhen prepi na mathi oti
 in no circumstance Kostas NEG must know that ...
 'Under no circumstances should Kostas find out that ...'

(23) Monaxa an vreksi o Kostas tha fighi
 Only if rains Kostas FUT leaves
 'Only if it rains will Kostas leave'

But the equivalent of only if is still not compatible with then:

⁷ I say "is not obligatory" because MG word order being very free, it will permit the subject to occur almost anywhere. The point is that unlike in English, or MG Wh-questions, V-movement is not forced with fronted negative elements.

- (24) **Monaxa an vrexsi (#tote) o Kostas tha fighi**
only if rains then Kostas FUT leaves

This means that the syntactic account for why only if and then cannot co-occur in English is not readily transferrable to Modern Greek.

The MG case that I just discussed is a case where then is not possible with only if, even though there is no V-movement in the relevant constructions. There is another way to show that blocking of V2 cannot be the (sole) culprit of the unacceptability of (18). There are languages where then and V2 are fully compatible. Dutch is such a language, where, as we saw in chapter 2, a fronted HC IF-clause behaves as a first element in V2, as in (25a). In such sentences then is perfectly acceptable, as in (25b):

- (25) a. **Als het regent zal ik naar school gaan**
if it rains will I to school go
'If it rains I will go to school'
- b. **Als het regent dan zal ik naar school gaan⁸**
If it rains then will I to school go
'If it rains then I will go to school'

But also in Dutch, only if and then cannot co-occur:

⁸ When there is both an IF-clause and then present in Dutch (and German) the verb appears in third position. There are some other (very few) cases where this happens.

26) Alleen als het regent (#dan) zal ik naar school gaan
only if it rains then will I to school go

In other words, in Dutch V-movement and then are compatible, but not in the case of only if. This indicates that the unacceptability of (18) cannot be straightforwardly attributed to the incompatibility of then with V2.

A final argument against V2 being responsible for the incompatibility of then with only if conditionals was suggested to me by David Pesetsky. He pointed out that in a sentence like (27a) V2 is not acceptable, that is (27b) with no V2 is much better:

- (27) a. ???If, and by the way only if, it rains will I visit you
b. If, and by the way only if, it rains I will visit you

The contrast in (27) is not surprising, given that parentheticals do not trigger grammatical operations in the main sentence. But notice that the presence of then in (27b) is not acceptable:

(28) #If, and by the way only if it rains then I will visit you

The unacceptability of then in (28) cannot be due to its blocking V2, since V2 would not apply anyway. Rather, it is the meaning of only if that seems to be incompatible with then.

Rather than try to find a language-particular account to preclude then from only if conditionals in each of all the languages where the

phenomenon holds, I will assume that there is a semantic account for the incompatibility of then and only if⁹ and I will now go on to suggest one.

I said before that the assertion of an only if conditional is such that it not only satisfies but in some sense strengthens the presupposition of then (as in (2b)). I also said that therefore only if would be predicted to take then. But this, in fact, might well be an ill-posed problem: it is possible that the fact that only if asserts what then presupposes is itself responsible for the unacceptability of sentences like (18). In other words, the fact that an only if conditional asserts what then presupposes might predict that only if and then should not co-occur, contrary to what was said above. This would be consistent with (or follow from) a more general constraint against asserting things that are presupposed. In the words of Stalnaker (1970, p.280):

"The boundaries determined by presuppositions have two sides.

One cannot normally assert, command, promise, or even conjecture what is inconsistent with what is presupposed.

Neither can one assert, command, promise or conjecture what is itself presupposed. There is no point in expressing a

⁹ David Pesetsky (p.c.) also suggested a modification of the NEG-inversion account suggested in the main text that might explain the cross-linguistic incompatibility of only if and then, namely that NEG-inversion be treated as a universal; in English it would happen at S-structure, in a language like MG, at LF. One would have to add, of course, that the fronted negative element requires the verb to be adjacent to it, to exclude sentences like (26) in Dutch. In such a case, the fact that the verb cannot climb over then to satisfy this requirement of only if results in unacceptability. It is possible that such an account is on the right track, but proving that NEG-inversion is universal is outside the scope of this thesis. Moreover, such an account seems less useful for our present purposes, given the discussion of (27) and (28).

proposition unless it distinguishes among the possible worlds which are considered live options in the context"

While the first cases that we discussed were cases of conditionals that cannot contain then because they violate what would fall under Stalnaker's "first side" in asserting or presupposing something that was inconsistent with the presupposition of then, the incompatibility of then with only if would appear to be due to the sentence asserting "what is itself presupposed".

Another proposal to account for (18) was suggested to me by David Pesetsky. He argues that we should change the presupposition of the statement "if p then q" from (2b) to (29):

(29) There is some proposition r compatible with $\sim p$, such that $\sim r$ implies $\sim q$ " AND there is some proposition r', also compatible with $\sim p$, such that r' implies q.

It is obvious that a sentence with only if does not satisfy the second conjunct of (29), although it does satisfy the first. If (29) replaces (2b) then we can account for (18). However, extending (29) for all the other cases seems problematic; it would mean that the speaker of a sentence like (30a) does not only believe a sentence like (30b), but also (30c) and (30d), which seems unlikely:

- (30) a. If it rains then I'll come
b. If it doesn't rain, I won't come
c. If it snows, I'll come

d. If it doesn't rain, I'll come

The extension of (29) to cases other than only if appears therefore not to be a correct move, making the restriction of (29) to only if seem rather idiosyncratic¹⁰.

3.1.3

In sections 3.1.1 and 3.1.2, I gave a proposal for the semantic contribution of then which accounts for why it is at times unacceptable. Two of the cases discussed were even if and only if conditionals. In this section I will outline a suggestion by Irene Heim (p.c.) intended to preclude the appearance of then with even/only if. Since this suggestion is particular to even and only, it is not intended to substitute for the proposal in (2), which makes predictions about different conditionals as well. Moreover the appearance of then with only if and even if might possibly violate both (2) *and* the constraint I am about to outline.

It has been argued that even and only are quantificational in nature. Since resumptive pronouns can never have quantificational antecedents in

¹⁰ Part of the difficulty in comprehending only if conditionals is due to their closeness in meaning to biconditionals. In logic textbooks one finds that "only if p, q" is equivalent to "if q, p". But if one combines this with presuppositional accounts of only (like Horn's (1969)), according to which "only if p, q" has the presupposition "if p, q", one derives the biconditional. It appears, in fact, that only if conditionals are understood as biconditionals by many people. If this is so then (2b) is vacuously satisfied because any sentence that is incompatible with the antecedent will by definition be incompatible with the consequent as well.

English, constituents modified by even or only can never be dislocated (31a), though they can be (marginally) topicalized (31b):

- (31) a. *every boy / (*only/*even) John, I like him
b. ?every boy/ (only/even) John, I like

If we treat then as a resumptive pronoun for the IF-clause, it will follow quite naturally that then cannot have the quantificational even if and only if as antecedents.

For this analysis to go through, then must crucially be a resumptive pronoun and not an anaphor or non-resumptive pronominal, since these can take quantificational antecedents:

- (32) a. every boy / (only/even) John likes his mother
b. every boy / (only/even) John likes himself

As I've already mentioned, accepting this suggestion does not automatically mean rejecting (2), since both may be operative. However, it seems that the proposed parallelism between then and resumptive pronouns leaves some open questions. First of all, a resumptive pronoun can appear far away from its antecedent; in fact, it is said that the more islands that intervene between the two, the more acceptable the resumptive pronoun is. But in the present case, we see that the IF-clause cannot be separated from then. Sentence (33) does not have a reading where the IF-clause belongs to

the embedded clause, which would be expected if then were a resumptive for the IF-clause¹¹:

(33) If it rains Mary thinks that then Bill will come

The relationship between then and the IF-clause is much tighter than the one between a resumptive pronoun and its antecedent. Not even parentheticals can intervene:

(34) *If it rains, I fear/in my opinion/etc., then we can't go out

The unacceptability of (34) suggests that the relation between the IF-clause and then is more like the relationship between a verb or a preposition and their objects, or, between an NP modified by a relative clause and the relative pronoun, none of which permit parentheticals:

- (35) a. *John saw, I fear/in my opinion, Mary
b. *John saw Mary under, I fear/ in my opinion, the table
c. *The man, I fear/in my opinion, who Mary likes, is coming to dinner

¹¹ A similar point was made in Collins (1989), where it was argued that the contrasts between (i) and (ii), and between (iii) and (iv) show that the presence of then blocks movement of the IF-clause:

- (i) It is if Bill comes home that Mary will leave
(ii) *It is if Bill comes home that then Mary will leave
(iii) It is if Bill comes home that John said that Mary would leave
(iv) *It is if Bill comes home that John said that then Mary would leave

One could argue that the unacceptability of (35a) is due to the parenthetical blocking Case assignment to the object, and that when Case is not an issue, the parenthetical is fine. This appears to be true; compare (35a,b) to the sentences in (36):

- (36) a. John put the book, I fear/in my opinion, in the aquarium
b. John believes, I fear/in my opinion, that gnomes stole his book

If Case is responsible for the ungrammaticality of (35a,b), then the strictness of the locality constraints on the relationship between the IF-clause and its "coreferent" then resemble only those between an NP and a relative pronoun^{12 13}.

¹² Sentence (34) is fine if the parenthetical follows then:

- (i) If it rains then, in my opinion/I'm afraid, we can't go

Similarly, if the parenthetical follows the relative pronoun, the sentence is acceptable. Compare (35c) with (ii):

- (ii) The man who, in my opinion/I fear, Mary likes, is coming to dinner

Moreover, if then or the relative pronoun are absent, the parenthetical is acceptable:

- (iii) If it rains, I fear/in my opinion, we can't go
(iv) The man, I fear/in my opinion, Mary likes, is coming to dinner

The acceptability of (iii) and (iv) indicates that the parenthetical stands where it does in (i) and (ii) respectively, and not in (32) and (33c). This is corroborated by the fact that the parenthetical in (iv) is interpreted as belonging to the relative clause and not to the matrix sentence. In other words, (iv) is not related to (v), but to (vi):

- (v) The man, I fear/in my opinion, is coming to dinner
(vi) I fear/in my opinion Mary likes the man

It seems unclear, then, how it can be argued that then is a resumptive pronoun, just calling it a pronominal won't do for the purposes of the proposal discussed, because plain (i.e. non-resumptive) pronominals have no trouble taking quantificational antecedents, as was shown in (32).

3.1.4 A modification of (2b)

I have argued so far that (2), repeated below, describes the distribution of conditional then:

- (2) a. statement= if **p**, then **q**
b. presupposition= "if \sim **p**, \sim **q**" is true
c. assertion = if **p**, **q**

In this section I would like to add one modification. Clause (2b) requires that the speaker *believes* that the negation of the actual antecedent will imply the negation of the consequent. However, this is too strong. It is permissible that the speaker *does not exclude* that the negation of the antecedent will imply the negation of the consequent. In other words,

13 If then seems to behave like a relative pronoun, it is reminiscent of the claim of Geis & Lycan (1990) that its appearance is an instance of a correlative construction, as exemplified in the following pattern, taken from them, judgments including:

- (vii) a.***Who steals my purse, him I won't like
b.**Where he goes, there I'll go
c.*When he leaves, then I'll leave
d. If he leaves, then I'll leave

They suggest that "the correlative construction is going out of the language....[(viid)] is its last remnant".

saying (4a) (If Quayle runs then the Republicans will lose) does not presuppose belief that (4b) is true (If Quayle doesn't run, the Republicans will win), as was argued in section 3.1.1, but that (4b) is possible. Put yet differently, (4a) presupposes that (4b) cannot be excluded, or that it cannot be asserted that (4b) is false. The negation of the actual antecedent does not have to imply the negation of the consequent for the presupposition of then to be satisfied; all that is necessary is that the negation of the antecedent be compatible with the negation of the consequent. This can be seen from the acceptability of (37) (and the contrast between (37) and (5) of section 3.1.1:

(37) If Quayle runs, then the Republicans will lose. If Quayle doesn't run, I don't know what will happen; they might win or they might still lose

The acceptability of (37) indicates that (2b) should be qualified as above, so that we now have (38) instead of (2):

- (38) a. statement= if **p**, then **q**
 b. presupposition= it cannot be asserted that "if $\sim p$, $\sim q$ " is false, i.e. $\sim p$ is compatible with $\sim q$.
 c. assertion = if **p**, **q**

The difference between (2b) and (38b) does not affect the discussion in sections 3.1.1 and 3.1.2 of the cases where the presence of then is degraded. For this reason, and since the formulation in (38b) is somewhat more complex than the one in (2b), I chose the simpler (2b) for ease of

exposition in those sections. As far as I can tell, the difference between (2b) and (38b) shows up only in cases like (37)¹⁴.

3.2.1

In the previous sections I suggested that there is a particular presupposition associated with then which regulates the possibility of its appearance. In this section I will discuss one more context in which the presence of then is degraded.

These are the cases in which the content of the IF-clause is referred to in the consequent:

- (39) a. If John comes to Cambridge (#then) it scares Mary
b. If John comes to Cambridge (#then) it bothers Mary
c. If John comes to Cambridge (#then) Mary hears it
d. If John comes to Cambridge (#then) Mary denies it

The judgments for all the sentences in (39) are on the reading where it refers to John's coming to Cambridge. In the above sentences, the antecedent must be (assumed to be) true for the consequent to be able to be evaluated. If John doesn't come to Cambridge, there will be nothing for Mary to report or to deny, or to be bothered or scared by. When the

¹⁴ Note that (36b) does not face the problem referred to in footnote 3. If the negated antecedent ends up as an impossible proposition (as was the case with the negation of "John is dead or alive") (38b) will not be satisfied, since an impossible proposition is not compatible with anything.

antecedent is not true, the consequent will suffer from presupposition failure. Recall that in order to use then it should be possible that the negation of the antecedent will make the consequent false, or after the modification of the previous section, that the negation of the antecedent must be compatible with the negation of the consequent. But in the sentences in (39), the negation of the antecedent will not be compatible with the negation of the consequent; the negation of the antecedent will make the consequent suffer from presupposition failure. In other words, the presupposition of then cannot be satisfied and its presence is predictably degraded.

The sentences in (39) were cases in which the antecedent is a presupposition of the consequent, and so are the examples in (40):

- (40) a. If Mary bakes a cake she gives some slices of it to John
b. If Mary composes a sonata she dedicates it to Bill
c. If Mary writes an article on knots it gets published in *Nature*

On the readings where Mary gives some slices of the cakes she bakes to John, she dedicates the sonatas she composes to Bill, and her articles on knots are published in *Nature*, the pronoun it is an E-type pronoun (Evans (1980), Heim (1990)). For example in (37b), it refers to the sonata Mary composed and thereby presupposes that Mary composed a sonata, i.e. it presupposes the truth of the antecedent¹⁵. In other words, if Mary doesn't bake cakes, compose sonatas, or write on knots, the consequents in (40a-c) will suffer from presupposition failure. Again, the presupposition of then

¹⁵ Diregarding the issue of uniqueness presupposition.

cannot be satisfied because the negation of the antecedent will make the consequent suffer from presupposition failure, that is, not be false, as the presupposition of then requires. The prediction is that then cannot appear in (40a-c) and this prediction is verified:

- (41) a. If Mary bakes a cake (#then) she gives some slices to John
b. If Mary composes a sonata (#then) she dedicates it to Bill
c. If Mary writes an article on knots (#then) it gets published in *Nature*

Now consider the sentences in (39). The presence of then in these sentences is much more acceptable than in the ones in (39) (although there is a considerable variation among speakers, which I will argue later represents a true ambiguity):

- (42) a. If Mary reads an article on knots (%then) she gives it to John
b. If Mary sees a cake (%then) she buys it for John
c. If Mary finds a stray dog (%then) she feeds it

The most obvious difference between the sentences in (39) and those in (39) is that in the former the IF-clauses contain verbs of creation, while in the latter they contain verbs of use (Erteschik-Shir (1981), Diesing (1991)).

The sentences in (39) are, in fact, ambiguous due to two possible interpretations of the pronoun it. On one of its interpretations, the pronoun it is interpreted as an E-type pronoun referring to the article read by Mary,

the cake seen by Mary, or the stray dog found by Mary. On these interpretations, the negation of the antecedent will again make the consequent suffer from presupposition failure.

But on another interpretation, the pronouns in (39), unlike those in (39) do not depend on the truth of their antecedent for satisfaction of its existential presupposition. The pronoun is a bound variable and as such has no presupposition:

(43) Always_x [[x an article on knots] & M. reads x] [M. gives it_x to J.]

I will return shortly to details of an account along these lines

It seems, then, that the '%' sign on (39a-c) reflects an ambiguity inherent in the IF-clauses in (39), but absent in those in (39). This ambiguity is, in fact, predicted by Diesing (1991). According to Diesing (1991), one of the differences between verbs of use and verbs of creation lies in the interpretations they permit for indefinite objects. Verbs of use permit both what Diesing calls the "quantificational reading" (44b) as well as the "existential reading" (44c):

- (44) a. I always read a book by Robertson Davies
b. Quantificational reading: Whenever I see a book by Robertson Davies, I always read it.
c. Existential reading: First thing in the morning, I always read a book by Robertson Davies

The representation she gives for the quantificational reading involves unselective binding, following Lewis (1975):

(45) Always_x [x is a book by Robertson Davies] I read x

The representation in (45) is the result of QR: the indefinite NP raises and adjoins to the IP, where it enters the restrictive clause of the adverb of quantification always (see Diesing (1991) for more details).

The representation given for the existential reading is:

(46) Always_t [t is in the morning] \exists_x [x a book by R.D. & I read x at t]

In (43), the variable corresponding to the indefinite NP is not bound by the adverb of quantification, but by Existential Closure (Heim (1982)), i.e. an existential quantifier is attached to the VP (the VP being for Diesing the domain of existential closure). Crucially for this reading, the indefinite NP does not raise outside the VP.

Unlike verbs of use, verbs of creation permit only the existential reading. So, as Diesing points out, (47a-b) are unambiguous (without focus or contrastive stress on any constituent):

- (47) a. I usually write a book about slugs
b. I usually draw a map of Belchertown

Obviously, (47b) does not mean "whenever there is a map of Belchertown, I draw it" (the quantificational reading) but "At most times, I am busy drawing a map of Belchertown". As Diesing notes, "one might say that things which are only just brought into existence cannot be mapped into a

Restrictive Clause, and are limited to only the cardinal (existential) reading " (p.192).

This important difference between verbs of creation and verbs of use seems also to be at play in (41)/(42). The content of the IF-clause of (42a) (repeated here as (48)), can give rise to two LF representations, corresponding to the quantificational reading (49a) and the existential reading (49b):

(48) If Mary reads an article on knots, she always gives it to John

(49) a. (IF) x an article on knots & Mary reads x

b. (IF) $\exists x$ [x an article on knots & Mary reads x]

Since the variable is free in (46a), it will be bound by the adverb of quantification, as we saw in (46) above, repeated here as (50):

(50) Always_x [[x an article on knots] & M. reads x] [M. gives it_x to J.]

The variable in (49b), however, is bound inside the VP of the IF-clause, and as a result will not be able to be bound by the adverb of quantification. In other words, when the IF-clause of (48) is interpreted along the lines of (49b), there is no unselective binding and the pronoun it is an E-type pronoun . It is on this construal that the pronoun in (42a-c) refers to the article on knots read by Mary, the cake seen by Mary, or the stray dog found by Mary. And on this construal, if the IF-clause of (42a-c) is not satisfied (as required by the presupposition of then), there will be no articles on knots read by Mary, or cakes seen by her etc., and therefore the

consequent will suffer from presupposition failure. On this reading (the E-type pronoun reading) the presence of then is degraded¹⁶.

On the other hand, if the IF-clause of (48) is interpreted along the lines of (49a), then the negation of the antecedent will not make the consequent suffer from presupposition failure: the pronoun it, being a variable, will have no presupposition to fail and will range over articles, cakes, and stray dogs in general. As a result, then is permitted. The possibility for those two interpretations is what accounts for the '%' in (42a-c); the difference between the two readings being subtle enough to give a Necker cube effect¹⁷.

According to Diesing, verbs of creation permit only the existential reading for an indefinite object. This means that in sentences like the ones in (41), the indefinite will be bound by existential closure and the pronoun will be an E-type pronoun. As a result, an antecedent incompatible with the actual one will always make the consequent suffer from presupposition failure in these sentences, explaining why then is degraded.

¹⁶ When applying the test with the negation of the antecedent, all indexicals should maintain their original reference, i.e. the pronoun it should keep its reference to "John comes to Cambridge" and should not switch to "John doesn't come to Cambridge" when the latter is substituted as the negated antecedent to satisfy (2b). Similarly later in this section the pronoun it in sentences like (41b) ("If Mary composes a sonata, she dedicates it to Bill") does not refer to "the sonata Mary didn't compose" when the negated antecedent "Mary doesn't compose a sonata" substitutes for the actual one in order to test the presupposition of then.

¹⁷ Diesing provides contexts that help disambiguate between the two readings, such as antecedent contained deletion; the use of free choice any and the possibility for scrambling in German are compatible only with the quantificational reading, while extraction is only compatible with the existential reading. The test with free choice any will not work, but the prediction is that whenever there is antecedent contained deletion in the IF-clause, and a coreferent pronoun in the consequent, the presence of then should be acceptable, since it is always acceptable with the quantificational reading of verbs of use:

- (i) If John reads books that Bill does (then) he gives them to Peter

Finally, experiencer verbs permit, according to Diesing, only the quantificational reading. This means that in sentences like (51a-b) the pronoun it is bound, along with the indefinite NP, by unselective binding:

- (51) a. If Mary likes a cake, she buys it for John
b. If Mary detests a film, she makes John watch it

This means that the negation of the antecedent will never make the consequent suffer from presupposition failure, which in turn predicts that the presence of then in (51) will be acceptable. This is true; compare (41) and (42) to (52):

- (52) a. If Mary likes a cake, then she buys it for John
b. If Mary detests a film, then she makes John watch it

It seems, then, that the data discussed in this section provide further support for the proposed account of then. In the next section, I will discuss two more characteristics of the conditionals in (39), (i.e. conditionals where the antecedent is a presupposition of the consequent) but which are not relevant to their inability to take then.

3.3 *Two side-points*

3.3.1 *'Only/even CP' needs Case*

Consider the data in (53) and (54). In these examples an IF-clause whose content is referred to in the consequent by the pronoun *it* cannot be modified by only or even:

- (53) a. ***Only if John goes to Cambridge does Mary report it**
b. ***Only if John goes to Cambridge will it scare Mary**
- (54) a. ***Even if John goes to Cambridge Mary reports it**
b. ***Even if John goes to Cambridge it will scare Mary**

The relevant readings are where the entire boldfaced IP is the associate of only and even and not a constituent contained therein. If a constituent inside the IP is the associate, the sentences are grammatical:

- (55) a. **Only if John goes to Cambridge does Mary hear it**
b. **Only if John goes to Cambridge will it scare Mary**
- (56) a. **Even if John goes to Cambridge Mary hears it**
b. **Even if John goes to Cambridge it will scare Mary**

The difference in the interpretation is brought out if one has in mind that in (55)/(56) the alternatives associated with only and even are along the lines of "(if) John goes to Philadelphia", "(if) John goes to Chicago" etc. But

the alternatives for (53)/(54) are of the type "(if) Bruce Springsteen comes to town", "(if) Chris performs at the Met", "(if) it snows a lot", etc.

According to Irene Heim the discussion of the semantic contribution of then as applied to the cases in section 3.2.1 can be extended to (53)/(54). Sentences containing only and even are associated with alternatives; I gave above some examples of alternatives for the cases where the associate is the entire antecedent of a conditional. In the case of only, all alternatives are supposed to imply the negation of the consequent. Following Horn (1969), a sentence like (57a) can be paraphrased as (57b) and a sentence like (58a) as (58b):

(57) a. Only John left

b. Every person different from John stayed

(58) a. Even John left

b. In addition to John, some person different from John, left (and that person was more likely to leave than John was)¹⁸

Applying this presuppositional account of only and even to conditionals where the entire IF-clause is the associate of only and even, by extending "different from" to "incompatible with", we get (59b) for (59a) and (60b) for (60a):

¹⁸ Alternatively, instead of (58b) we could have "In addition to John, every person different from John left, and all these persons were more likely to leave than John", where "every person" ranges over some relevant domain.

(59) a. Only if **p**, **q**

b. Every **r**, **r** incompatible with **p**, implies \sim **q**

(60) a. Even if **p**, **q**

b. In addition to **p**, some **r**, **r** incompatible with **p**, implies **q**

In (59b) and (60b), **r** is compatible with \sim **p**, and when **p** is a presupposition of **q**, \sim **p** will make **q** suffer from presupposition failure. In other words, if we were to add then to (57a) and (58a), the meanings of only and even would be in conflict with the presupposition of then, resulting in degraded sentences as we saw in (53) and (54).

Finally in this section, I will briefly point out some other instances where a CP cannot be modified by only or even but for reasons entirely different from the aforementioned. An extraposed CP can never be modified by only or even:

(61) a. *I resent it only that he hit Bill

b. *He admits it only that he hit Bill

c. *I resent it even that he hit Bill

d. *He admits it even that he hit Bill

It seems, in fact, that only and even can modify a CP only if the latter is in a Case-marked position (or is an adjunct). In (61) the extraposed clause is not in a Case-assigned position. When the clause is not extraposed, only and even are perfectly acceptable:

- (62) a. I resent only/even that he hit Bill
b. He admits only/even that he hit Bill

Only and even cannot modify a CP inside a complex NP, which is also not a Case assigned position:

- (63) a. *The fact only/even that John and Bill eloped to Gretna Green
b. *My belief only/even that the earth is round
c. *The rumour only/even that John will arrive at 10pm

Neither can they modify a CP complement of an adjective:

- (64) a. I am proud/angry/etc that John left without complaining
b. *I am proud/etc only/even that John left
c. *I am proud John

Sentence (64a) is grammatical because a plain CP does not need to be in a Case-marked position, a CP modified by only or even does, and hence the status of (64b).

There are double object verbs which allow one object to be a CP. These verbs divide into two categories with respect to whether their CP complement can be modified by only or even:

- (65) a. He told me only/even that John had hit Bill
b. He promised me only/even that he would quit smoking

- (66) a. He persuaded me (*even/*only) that the earth is flat
 b. He warned me (*even/*only) that he would be late

This division is exactly the division between verbs that can and verbs that cannot take an NP object in the position of the CP in (65)/(66), i.e. those that can and those that cannot assign Case to that position:

- (67) a. He told me a story
 b. He promised me the moon
- (68) a. *He persuaded me his theory
 b. *He warned me the disaster

The contrast between (65) and (66) therefore adheres to the generalization proposed here¹⁹.

Similarly, CPs that are associated with an expletive cannot be modified by only or even:

- (69) a. It is obvious (??only/??even) that John hit Bill
 b. It is well-known (??only/??even) that John is angry with Bill

¹⁹ The empirical generalization that [only/even CP] is acceptable only in a Case-marked position holds also for Modern Greek and Catalan. I have found only one exception to this paradigm and only for some English speakers. This is the verb convince, which for some speakers can take a CP modified by only or even, but not an NP:

- (i) He convinced me only/even that the earth is flat
 (ii) *He convinced me his theory

Contrast the sentences in (69) with the corresponding sentences in (70), in which the CP is in the (Case-assigned) subject position:

- (70) a. Only/even that John hit Bill is obvious
b. Only/even that John is angry with Bill is well-known

The contrast between the judgment of '??' in (69) versus that of '*' in the previous sentences, if it's real, might be due to the CPs in (73) being associated with a Case-marked position through their association with expletive *it*, which is assigned Case. Howard Lasnik (p.c.) points out that this might be an argument in favour of Case transmission.

So far we have seen that only and even can modify an argument CP only if the latter is in a Case-marked position. Why should this be?

It is possible that the answer can be given by the theories for which only and even create quantificational constituents. In such proposals only/even and their associate undergo QR at LF leaving a variable behind. However, all variables, traces of A-bar movement, must be assigned Case²⁰.

Therefore only and even can only modify a CP in a position that is assigned Case.

This is similar to the observation in Safir (1981), where it was argued that although a CP does normally not need Case, when it is extracted it does:

²⁰ This holds for variables in positions other than adjuncts. In a sentence like (i), it is not obvious that or how the EC gets Case:

- (i) Why₁ did John leave EC₁?

- (71) a. John is angry that Mary left
 b. *What is John angry?

What is proposed here is that the contrast between (71a) and (71b) holds also for LF movement²¹.

Although only and even can only modify argument CPs in a Case-marked position, they can freely modify adjunct CPs:

- (72) a. I will come only/even if it rains
 b. I see him only/even when he gets paid
 etc.

But the data in (72) are not a counterexample to the generalization proposed, because adjuncts never need Case. They are visible (if that is what Case is needed for, although see Epstein (1990)) and freely extractable without it:

- (73) Where/how/when/etc did you see Bill?

²¹ One might ask why a sentence like (58b) cannot be saved by *of*-insertion the way (71c) can:

- (i) a. I am proud of John
 b. *I am proud (of) only/even (of) that John left

This might be explainable if *of*-insertion is a PF phenomenon, that comes too late to save something that happens at LF. This would imply that NPs do not need Case until PF. And this is too big a question for the present context.

Since the trace left by syntactic A-bar movement of an adjunct does not need Case, it is not surprising that the trace left by LF-movement doesn't either.

3.3.2 *pro* cannot refer to events

The discussion in this section involves data like (39) (conditionals whose IF-clause is a presupposition of their consequent) in pro-drop languages. When a (clitic) pronominal in the object position of the consequent refers to the content of the IF-clause, nothing unexpected happens:

(74) An ftasi o Kostas arga i Maria tha to paradhexti (Modern Greek)
 If arrives the K. late the M. FUT it admit
 'If Kostas arrives late, Mary will admit it'

(75) Se Gianni arriva tardi, Maria lo ammetera (Italian)
 if John arrives late Mary it admit/FUT
 'If John arrives late, Mary will admit it'

Things take a different turn, however, when we try to put the pronominal in subject position. We see that *pro* is not permissible:

(76) *An ftasume arga tha tromaksi tin Maria (MG)
 if we arrive late FUT scare the Mary/ACC

(77) *Se vado a Venezia spaventera Maria (Italian)

If I go to Venice will scare Mary

The direct translation into Modern Greek of e.g. (39a) with pro is acceptable. But as the indexing and the translation indicate, pro is understood as referring to John and not to the content of the IF-clause:

(78) An erthi o Kostas₁ sto Cambridge pro₁ tha tromaksi tin Maria
If comes the K. to Cambridge will scare the M.
'If Kostas comes to Cambridge, he will scare Mary'

This confusion is avoided if a third person singular subject is not used in the IF-clause.

Sentences (76) and (77) improve if a demonstrative is used to refer to the IF-clause:

(79) An ftasume arga afto tha tromaksi tin Maria (MG)
if we arrive late this will scare Mary

(80) Se vado a Venezia questo spaventera Maria (Italian)
if I go to Venice this will scare Mary

(79) and (80) have the same status as the English (81):

(81) If John comes to Cambridge this (very fact) will scare Mary

And like in English, if the IF-clauses of (79) and (80) are sentence-final, the sentences become ungrammatical:

(82) *This (very fact) will scare Mary if John comes to Cambridge

(83) *Afto tha tromaksi tin Maria an ftasume arga

(84) *Questo spaventera Maria se vado a Venezia

The ungrammaticality of (82)-(84) is easily accounted for since, as we saw in Chapter 1, the matrix subject *c*-commands the IF-clause when the latter is sentence-final. This means that (82)-(84) are Binding Condition C violations: the content of the IF-clause refers to an event, this CP is an R-expression which should be free in the sentence but isn't in (82)-(84) because it is *c*-commanded by the co-indexed demonstrative. The source of the ungrammaticality of these sentences is the same as that of (85b) (taken from Pullum (1987)) where the boldfaced pronominal refers to the event expressed by the boldfaced clause. (85a) is grammatical because *it* does not *c*-command the boldfaced clause leaving that free in its sentence:

(85) a. The fact that you believed **it** is what first made me suspect that **the butler was guilty**

b. *It led me to think that someone else would know that **the butler was guilty**

Returning to (76) and (77), we saw that although it is possible to salvage these sentences using a demonstrative, it is not possible to use *pro* (referential or expletive) to refer to the event expressed by the IF-clause. In fact, it seems that (86) holds:

(86) pro cannot be used to refer to an event at all.

In support of (86) compare the English (a) sentences to the MG (b) sentences with pro instead of it (Italian, Catalan and Spanish behave like MG in this respect):

(87) a. Forty years after the decipherment of Linear B, it continues to provoke many debates

b. *Saranda xronia meta tin apokriptografisi tis Gramikis forty years after the decipherment of Linear

Vita, pro sinexizi na prokali poles sizitisis

B, continues provoke many discussions

(88) a. She heard that Ventris had deciphered Linear B and it impressed her

b. *Dhiavase oti i Germania ixē bi stin Polonia ke (he/she) read that the Germany had entered into Poland and

pro tin tromakse

her scared

Why should pro not be able to refer to events? I am not going into this to go in great detail, but I think an approximation to an answer (but with many loose threads) could be the following: pro is, or is licensed by, a

realization of Phi-features and events lack. That events lack Phi-features can be seen even in English, with the realization of the feature Plural:

- (89) A: I saw **John leave**
B: I saw **it too**

but:

- (90) A: I saw **John leave and Mary arrive**
B: *I saw **them too**

Similarly if we try to pluralize the events in (91) and (92)²²:

²² I have not been distinguishing between NPs and CPs referring to events. The empirical generalization that events cannot be referred to by a plural pronoun holds in absolute terms when a CP is used. When an NP is used the pattern is less homogeneous:

- (i) A: I witnessed **John's departure and Mary's arrival**
B: I witnessed **them too**

Reference to events by NPs also differs from reference to them by CPs in that the former but not the latter trigger plural agreement on the verb:

- (ii) **John's departure and Mary's arrival scare me**
(iii) ***That John left and Mary arrived scare me**

I don't know why this is.

McCloskey (to appear) points out that two CPs trigger plural agreement "just in case the conjoined propositions are contradictory or incompatible—that is, when they specify two (or more) disjoint states of affairs or situation types. When the co-ordinated clauses denote compatible propositions (that is, when they denote two or more propositions which jointly specify a single complex state of affairs or situation types), then singular agreement is preferred or required:

- ((iv)) That UNO will be elected and that sanctions will be lifted is now equally likely.
((v)) ??That UNO will be elected and that sanctions will be lifted` are now likely.
....
((vi)) That the shares are overvalued and that a decline is in order is widely believed on Wall St.

(91) *Forty years after the decipherment of Linear B and the decoding of DNA, they continue to inspire a lot of literature

(92) *She heard that Ventris had deciphered Linear B and (that) Watson had decoded DNA and they impressed her

The above seem to indicate that events lack, or do not trigger, Phi-features (or modulo footnote 19, reference to events by CPs). It is therefore unsurprising that pro cannot be used to refer to them. However, this leaves open two questions, which I will not attempt to address here:

(93) why is it possible to use it to refer to a CP/event, as in (39), (87a), (88a) and (94), or accusative pronouns in Italian and MG as in (74) and (75)?

(94) If pro has to be associated with Phi-features, how can there be expletive pro?

Finally, (86) seems not to be applicable when the verb of the consequent is the copula:

(95) An o Kostas argisi tha ine dropi (MG)
If the K. is late FUT be shame
'If Kostas arrives late, it will be shameful'

[(vii)] ??That the shares are over-valued and that a decline is in order are widely believed on Wall St."

(96) Se Gianni arriva tardi, sara una brutta cosa (Italian)
If John arrives late will be a bad thing

(97) Se Gianni arriva tardi, sara stupido
If John arrives late will be stupid
'If John is late, it will be stupid'

The same holds for raising predicates:

(98) An argisume tha fani agenes (MG)
if we are late will seem impolite
'If we are late, it will seem impolite'

(99) Se vado a Venezia sembrera stupido (Italian)
If I go to Venice will seem stupid
'If I go to Venice, it will seem stupid'

One obvious difference between the subject positions in (98)-(99) and the ones in (76)-(77) is that in the latter it is assigned a theta-role and in the former it is not²³.

²³ With Passives, the judgments I get are mixed. The MG (i) is acceptable for me and other native speakers, but the one Italian speaker I asked finds (ii) worse than (100)-(104), although not as bad as (82):

(i) An argisume tha dhimosiefti
If we are late will be published
'If we are late, it will be published'

(ii) ??Se Gianni arriva tardi, sara racontato a tutti
If John arrives late, will be told to everybody

I will leave discussion of the pattern described in this section for some future occasion.

..

CHAPTER 4

THE SYNTAX OF "THEN"

0.

In the previous chapter I made a proposal about the semantic contribution of conditional then. In this chapter I will discuss some questions that arise with respect to its syntax.

4.1.1 *What follows then*

The first question that arises regards the nature of the maximal constituent that can follow then. In English, this appears to be a full clause:

- (1) a. If it rains then I will visit you
- b. If it rains then this umbrella I will buy
- c. If it rains then what shall we eat?¹

¹ A question that arises with respect to (1c) is that it is interpreted as a matrix question. This means that the features of the WH-phrase percolate up (or whatever) over then to form a matrix question. But in an embedded question they cannot do so to satisfy the selection requirements of a higher verb:

- (i) I wonder if it rains (*then) what we shall do

This is reminiscent of another instance where a WH-phrase can form a matrix but not an embedded question. This is the case of pied piping:

- (ii) Columbus's discovery of which country pleased the king of Spain?

but not:

- (iii) *I wonder C's discovery of which country pleased the king of Spain

- d. If it breaks down then call the mechanic, not me!
- e. If he's right then what a fool I've been

From (1a), we can see that then can be followed by an IP. Depending on one's view of topicalization, that is, whether it is adjunction to IP (as in Lasnik and Saito (1991)) or movement to [SPEC,CP] (Chomsky, class lectures (1990)), one can conclude from (1b) that then can be followed by an IP or a CP respectively. Similarly, depending on one's view of matrix WH-questions, that is, whether it is movement to [SPEC,IP] (Pesetsky (1988)) or to [SPEC,CP] (Chomsky (1986)), one can conclude from (1c) that then can be followed by IP or CP respectively. But even if the choice between IP or CP is controversial in (1b,c), from (1d,e) we can assume that then can be followed by CP, since, as far as I know, nobody has argued that imperatives or exclamatives are contained inside the IP. Our first observation about the syntax of then is, then, that it can (but of course doesn't have to) be followed by a CP.

4.1.2 Positioning

The second obvious question that arises is whether then is adjoined to the CP that follows it, or whether it is contained in a maximal projection that embeds the CP. The question, in other words, is whether (2a) or (2b) is the correct structure:

I'll temporarily assume that whatever is responsible for the contrast between (ii) and (iii) is also responsible for the contrast between (1c) and (i).



There seem to be some arguments in favour of (2b). These are all based on the following difference between the two structures in (2): if the conditional is embedded, then the CP will be governed by the higher verb if (2a) is the correct structure, but it will not be if (2b) is. The intervening XP will block government of the CP by the embedding verb in (3b), but the adjunction segment in (3a) will not:

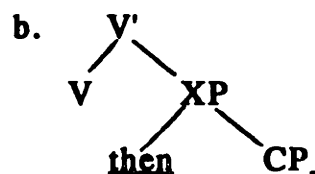
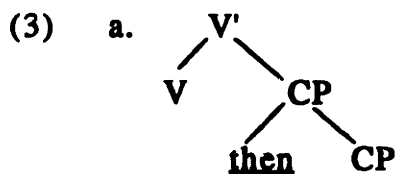

As a result, phenomena that are sensitive to government should distinguish between (2a)/(3a) and (2b)/(3b). Two such phenomena are embedded questions and extraction, and they both point towards (2b)/(3b) as the correct structure.

Verbs like ask and wonder select for a CP with a [+WH] head. In turn, this [+WH] head requires an appropriate specifier for agreement, this being any WH-phrase, including the null counterpart of whether, following Larson (1985). Since selection is satisfied under government, the verb must govern the CP containing the WH-head and phrase. Adjoined elements to a projection do not block government of that projection from a higher head. For example, Clitic Left Dislocation structures do not block the

selection between the higher verb and the embedded WH-phrase, since the CLLDed constituent is adjoined to the embedded CP (Iatridou (1990)). The following is in Modern Greek, but the same effect holds in Italian:

- (4) Anarotieme [ton Kosta [pios ton idhe]]
 (I) wonder the Kosta/ACC who him saw
 (roughly) "I wonder who saw Kostas"

In English, it is harder to find elements adjoined to the CP. I will argue that IF-clauses can, but a more neutral case might be only and even. That these elements are adjoined to the constituents they appear next to can be argued for by the fact that they do not block Case assignment or subcategorization, and they can be followed by an embedded question, without blocking access to the latter of the higher verb:

- (5) a. I saw even/only John
 b. He said even/only that John is sick
 c. He wonders even whether John loves Mary
 d. He asked only what John ate

The same considerations apply for the structures in (3): in (3a) the verb governs the CP, but in (3b) it does not. This means that if an embedded question under then is possible, (3a) is the correct representation; if it is not possible, then (3b) is. And we see that the latter is the case; in (6) we see that a conditional without then can be embedded under a verb like ask or wonder, (thereby also confirming the suggestion in Chapter 1 that an IF-

clause can be adjoined to the CP). But a conditional containing then cannot contain an embedded question, as in (7)²:

- (6) a. Every boy wonders if his mother comes what he will eat
b. Every boy asks himself if he flunks his courses what is going to happen
- (7) a. *Every boy wonders if his mother comes then what he will eat
b. *Every boy asks himself if he flunks his courses then what is going to happen

The ungrammaticality of the sentences in (7) means that, under present assumptions, the matrix verbs do not govern the CP below then and that therefore (2b)/(3b) is the right structure, i.e. there is a separate maximal projection that contains then and which embeds the CP.

WH-extraction is another phenomenon that is sensitive to government and is therefore able to help us distinguish (2a)/(3a) and (2b)/(3b). Extraction from a CP is possible only under certain conditions. Ignoring intricacies of a long and involved debate, for the present purposes I will follow Chomsky (1986), according to whom these conditions are L-marking (i.e. government by a lexical category) by an embedding verb. This means that elements adjoined to an embedded CP do not block extraction from within it, since they do not constitute a barrier to

² In order to avoid the parenthetical reading of the IF-clause (which would make it "transparent" in some fashion and permit the higher verb to govern the CP over it) I will be putting pronouns inside it which should be interpreted as being bound by the QP in the matrix sentence.

government of that CP by the higher verb. Consider again the case of Clitic Left Dislocation, where extraction of pos ('how') is possible from the CP to which to podhilato ('the bicycle') is adjoined:

- (8) Pos₁ ipes to podhilato oti tha to ftiaksi o Kostas EC₁
how (you) said the bicycle that FUT it fix the Kostas/NOM
(roughly) "How did you say that Kostas will fix the bicycle?"

Returning to the structures under consideration, the prediction is that if extraction from below then is possible, then the CP below it is governed by the higher verb and that (2a)/(3a) is the correct structure. If extraction is not possible then the CP below then is not governed by the higher verb, pointing towards (2b)/(3b) as the correct representation. And we find that the latter is the case. WH-extraction from an embedded conditional without then is possible (again confirming the adjoined status of the IF-clause), but impossible from a CP below then:

- (9) a. How/where did every boy say that if his mother comes the car will be fixed?
b. What did every boy say that if his mother comes the guests will eat?
- (10) a. *How/where did every boy say that if his mother comes then the car will be fixed?

- b. ??What did every boy say that if his mother comes then the guests will eat?³

The status of (10a,b) indicates that (2b)/(3b) is the correct structure, corroborating the conclusion we reached from the discussion of (6)-(7) above. In other words, it seems that then is not adjoined to the CP that follows it but contained in a maximal projection that embeds that CP.

There is a need for a short digression here. I argued before that only and even are adjoined to the CP they appear next to. This means that, in combination with the recent discussion, I am making the prediction that extraction from below that CP should be possible. This prediction is verified, but the data need some explication.

When only and even are followed by a CP, they can have either that whole CP as their associate, or something inside it, as for example the underlines constituents in (11b,c):

- (11) a. John said even/only that Bill loves Mary
b. John said even/only that Bill loves Mary
c. John said even/only that Bill loves Mary

This difference in associates is highlighted if one keeps in mind that the alternatives for (11a) are along the lines of "(that) it is raining", "(that) Pavarotti is coming to town", etc. While the alternatives for (11b) are of

³ The difference in judgment between '*' for (10a) and '??' in (10b) is consistent with these sentences being extraction of an adjunct and of an object out of a non-L-marked maximal projection.

the type "(that) Peter loves Mary", "(that) Sandra loves Mary" etc and for (11c) "(that) Bill loves Kathy", "(that) Bill loves Michael" etc.

The difference in associates influences the possibilities for extraction from the CP below only and even. More specifically, it is impossible to extract the associate of even and only outside their scope. The ungrammaticality of (12a) shows that this holds at S-structure and the fact that (12b) has only the reading where the subject has scope over the object, (i. e. it lacks the reading in which everyone raises to take scope over the subject) shows that this holds at LF:

- (12) a. *Who did John say even/only that Bill loves?
b. Someone even/only loves everyone

In other words, the associate of even and only must be lexical (Tancredi (1990)).

However, it isn't just the associate that cannot be extracted. It is also impossible to extract a subconstituent of the associate:

- (13) *Who did John say even/only that Bill loves?

The same phenomenon holds at LF. (14) is ambiguous between the reading where somebody has scope over the object and the reading where the object raises to take scope over somebody:

- (14) Somebody loves everybody's brother

But if we introduce only and even and give them everybody's brother as associate, the sentence becomes unambiguous; it lacks the reading in which the object has scope over the subject:

(15) Somebody (even/only) loves (even/only) everybody's brother

The absence of the aforementioned reading in (15) is due to even and only not permitting everybody to raise at LF.

The facts in (13) and (15) might be explainable in the theories in which even and only create quantificational constituents which raise at LF. As is generally the case, a focussed constituent cannot be questioned. Maybe it is impossible to extract (at S-structure or LF) from within a constituent that must itself extract because it is impossible to create a (S-structure or LF) variable within a (LF) variable. In other words, the range of a variable cannot contain any variables itself. But whatever the explanation of (13) and (15), the facts are clear: it is impossible to extract from within the associate of only and even, just as it is impossible to extract the associates themselves. In other words, extraction from a CP below only and even is restricted, but for reasons independent of the generalization proposed here, according to which elements adjoined to the CP do not block extraction from within the CP.

When none of these factors interferes, extraction from the CP is possible. That is, when a constituent of the CP is the associate of only and even, another constituent can extract:

- (16) a. Who did John say even/only that Bill loves?
b. How did John say even/only that Bill spoke to Mary?

To summarize the argument so far, the extraction possibilities from within a CP preceded by **only** and **even** are limited, but are so due to independent properties of these lexical items. When these properties do not interfere, extraction is possible, thereby confirming the position that elements adjoined to a CP do not block extraction from within it⁴.

Finally in this section, I will point out one more set of extraction data that seems to argue for (2b)/(3b) and that is the extraction of the IF-clause itself. In Chapter 4 I mentioned that when **then** is present, the IF-clause cannot extract long distance:

- (17) *[If it rains]₁ Mary thinks that EC₁ then Bill will come
- (18) a. *It is if Bill comes home that then Mary will leave (Collins (1989))
b. *It is if Bill comes home that John said that then Mary would leave

⁴ Another case in question is constituent negation on the CP which seems to be adjoined, judging from the fact that it doesn't block Case assignment or selection:

- (i) He said not that John is sick but that Peter loves Mary
(ii) He loves not John but Mary
(iii) He asked not what his country can do for him but what he can do for his country

But extraction from within a CP with constituent negation is not possible:

- (iv) *Who did he say not that Peter loves?

It's possible that this is due to the same reason that rules out (13) and (15): constituent negation makes a constituent quantificational, which is especially clear when it is contrasted with alternatives as in (i)-(iii).

As before, this indicates that then adds a barrier for extraction. In the next section I will argue that the IF-clause is adjoined to the maximal projection containing then and not contained in it as, for example, its specifier. If this is correct, then the data in (17) and (18) would seem to indicate that if a constituent is an island for extraction due to it not being L-marked, then elements that are base-generated adjoined to that constituent are also incapable of moving out of it. In other words, it seems that for the purposes in question, domination by only one segment counts as containment, contrary to May (1985) and Chomsky (1986)⁵.

4.1.3 *Head or Specifier*

So far in this chapter I have argued that conditional then is contained in a maximal projection that embeds the consequent. The next question that I will address is whether then is the head of this maximal projection or a maximal projection contained under it (for example as a specifier). The question is, then, between (19a) and (19b):

⁵ In Iatridou (1990) I reached the same conclusion for movement of the Clitic Left Dislocated constituent, which I argued is adjoined to the minimal CP containing the associate clitic. It should be pointed out that both in CLLD and the present case, the adjunction in question is base-generated adjunction, leaving open the possibility that adjunction created by movement might behave differently. This is not really relevant for (17) and (18), however, because the IF-clause appears in the sentence-initial position of the clause it is interpreted in by base-generation, as was argued in Chapter 1.

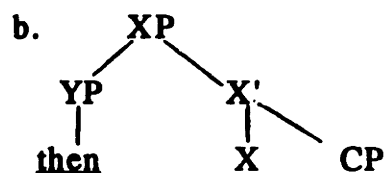
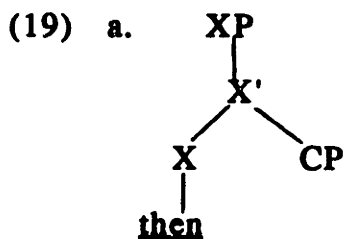

Without considering the evidence overwhelming, I think that there might be reason to believe that (19b) is the correct representation. First of all, one difference between (19a) and (19b) is that (19a) assumes that then may have a specifier and must have a complement, whereas (19b) permits the possibility that then is, or differently put, exhausts a maximal projection. This would put it on a par with pronouns, proper names, adverbs and other elements which are argued to be exhaustively dominated by a maximal projection. And although this is hard to express concretely, I have the intuition that conditional then is one such element. The temporal adverbial then is a maximal projection and conditional then is too close to it to differ in this particular respect. Moreover, it is hard to imagine what a specifier or a complement of conditional then would be or be like; it doesn't seem that it needs auxiliary elements to obtain a semantic value, as is the case for verbs, nouns, etc.

Maybe a stronger argument in favour of (19b) comes from a cross-linguistic comparison between English on the one hand and Dutch and German on the other and this will unfortunately lead us to a somewhat long digression.

In Dutch and German, a sentence-initial IF-clause behaves as the first element in V2:

- (20) Als Jan komt kom ik ook (D)
 If John comes come I too
 'If John comes I will come too'

Current analyses of V2 argue that the first element is in the [SPEC,CP] and the verb in the head of that CP. In other words, the structure of (20) would be as in (21):

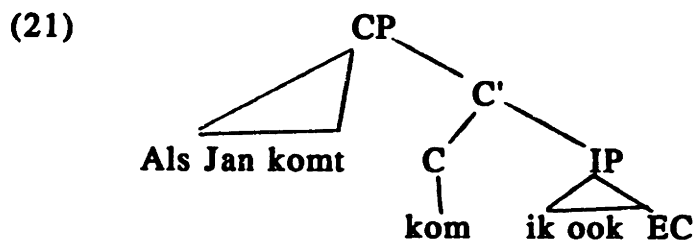

That the IF-clause causes inversion indicates that it stands in the [SPEC,CP] and it predicts that extraction from the consequent should not be possible. This is true; compare the ungrammaticality of the German (22) to the grammaticality of its English counterpart in the translation:

- (22) *Was sagte Johann wenn Maria kommt gehe er essen?
 What said John if Mary comes goes he eat
 'What did Mary say that if John comes he will eat?'

This difference between English and German/Dutch is in a way transparent: the sentence-initial IF-clause stands in the [SPEC,CP] in Dutch and German and like most sentence-initial elements in these languages behaves as the first element in V2. English, on the other hand, is not a productive

V2 language and most sentence-initial elements do not cause V2. This difference is replicated by many fronted elements:

- (23) a. **Yesterday I went to school**
b. **Gisteren ben ik naar school gegaan**
yesterday am I to school gone
- c. **This book I have given to John**
d. **Dit boek heb ik aan Jan gegeven**
this book have I to John given
- e. **This I want to do**
f. **Dit wil ik doen**
this want I do
- g. **That John is sick I know**
h. **Dat Jan ziek is weet ik**
that John sick is know I

But this clearcut distinction between English and Dutch/German is only partial: in the latter languages almost everything that is sentence-initial causes V2 and everything that causes V2 creates an island; in English only some sentence-initial elements cause V2 (24a), and these create islands (24b), but of the sentence-initial elements that do not cause V2, some create islands (25a) and some don't (25b):

- (24) a. Never in his life has John seen such good scores
 b. *How₁ did Bill say that never in his life did John fix the car EC₁?
- (25) a. *How₁ did Bill say that this bicycle John has fixed EC₁?
 b. How₁ did Bill say that yesterday Peter had fixed the car EC₁?

In other words, it is not possible that the crucial difference between English and Dutch/German is only that sentence-initial elements cause V2 in Dutch/German but not in English. Rather, the picture that arises is that sentence-initial elements in Dutch/German stand in [SPEC,CP] and that in English sentence-initial elements fall into two categories: those that form islands and are therefore arguably in [SPEC,CP] (some of these, like affective elements, cause V2; others do not), and those do not form islands and are therefore not in [SPEC,CP] but adjoined to the IP (or CP). Of the categories that do not cause V2, the first (i.e. those that create islands) seems to describe sentence-initial arguments (as in (25a)) and the second (i.e. those that do not create islands) sentence-initial adverbials or other adjuncts (as in (25b)). The difference in behaviour between IF-clauses in English and Dutch/German falls in this last category: in Dutch/German they stand in the [SPEC,CP] causing V2 and islandhood, in English they are adjoined to the IP/CP, not causing islandhood.

So far we have seen that the difference between IF-clauses in German/Dutch and English fall within a general pattern of differences among those languages. Now let's go back to conditional then. The question is to what extent we can consider English then similar to Dutch dan and German dann. The words are cognates and seem to have the same semantics. But is their syntax the same?

Dan(n) must be immediately followed by the verb in a matrix sentence:

- (26) Als je weggaat dan ga ik ook weg
if you away go then go I also away
'If you leave then I will also leave

Using the tests of the previous section to see whether dan(n) is adjoined to the consequent or contained in a maximal projection that embeds it will not work since as we just saw above in (22), extraction from the consequent, even in the absence of dan is not possible. But rather than proclaiming total agnosticism, let's assume that also in Dutch and German the equivalent of then are contained in an XP that embeds the consequent. Unfortunately, we can assume only so much about such a similarity, because unlike in English, in Dutch/German dan(n) cannot be followed by a question or topicalization:

- (27) a. *Wenn es regnet, dann was machen wir
if it rains then what do we
b. *Wenn es regnet, dann dieses buch solltest du lesen
if it rains then this book must you read

In (27a) there are three elements in front of the verb: the IF-clause, dann, and the WH-word was. In (27b) there are the IF-clause, dann, and the topicalized constituent dieses buch. One might argue that three elements before the verb are way too many and that there isn't one in particular that is responsible for the ungrammaticality of the sentences in (27). However, if we reduce the number of pre-verbal elements by one, we get one

acceptable and one unacceptable combination. If we remove dann as in (28a,b), the resulting sentences are equally ungrammatical; in other words with just the IF-clause and WH-phrase or topicalized constituent we still get an ungrammatical sentence. But if we remove the WH-phrase or the topicalized constituent but leave the IF-clause and dann we get acceptable sentences:

- (28) a. *Wenn es regnet, was machen wir ⁶
 if it rains what do we
- b. *Wenn es regnet, dieses buch solltest du lesen
 if it rains this book must you read
- c. Wenn es regnet dann solltest du dieses buch lesen
 if it rains then must you this book read

It seems, then, that in German (28c) and Dutch (26) we have a rare case where two elements can appear before the verb. The difference in status

⁶ Irene Heim (p.c.) pointed out to me that when the topicalized constituent contains an anaphoric reference to a constituent of the IF-clause, these sentences are fine. Compare (28a,b) to (i) and (ii):

- (i) Wenn einer mich anschreit, den zeige ich an
 If someone me yells-at, him/that one report I
 "If someone yells at me, I report him to the police"
- (ii) Wenn einer mich anschreit, dessen Auto mache ich kaputt
 his car make I broken
 "If someone yells at me, I destroy his car"

I have no explanation for this. Sentences (i) and (ii) are ungrammatical with dann.

between (28c) and (28a,b) obviously lies in the difference between dan(n) and a WH-word or topicalized constituent⁷.

Following all of the above, as well as the idea that in V2 the element immediately to the left of the verb is in the specifier of that maximal projection, and assuming that also Dutch/German have a separate XP that contains then and embeds the consequent, we are led to conclude that dan(n) stands in that position and that the IF-clause is adjoined to the XP:

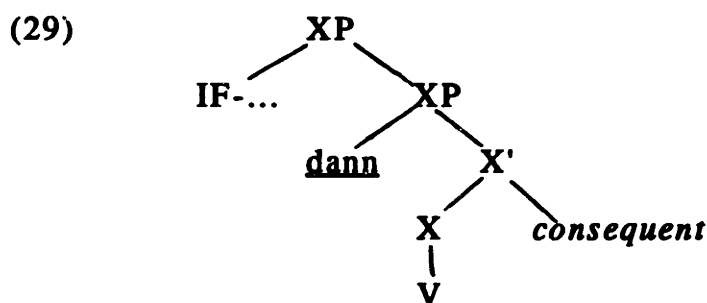

But if (29) is correct and if we want to take cross-linguistic evidence seriously, then (19b) must be the correct structure for English as well. Since the XP containing dann/then must have its head free to receive the verb in V2, it follows that dann/then cannot be that head. Since dann immediately precedes the verb, it follows that dann (and therefore then) is the specifier of XP. The position of the IF-clause is, unfortunately, gotten by elimination; within present theoretical assumptions there is no place for it but to be adjoined to XP:

⁷ I don't know what this difference might consist of. One possibility might be that elements that are speaker oriented or about the sentence as a speech act do not count for V2. This would include the IF-clause of the Relevance Conditional (see Chapter 2) as well some other elements (aber, "but", denn, "therefore", among others). Possibly, then is speaker oriented through the presupposition about the speaker's beliefs that it introduces, as discussed in the previous Chapter. But it is far from clear that this suffices.

(30)

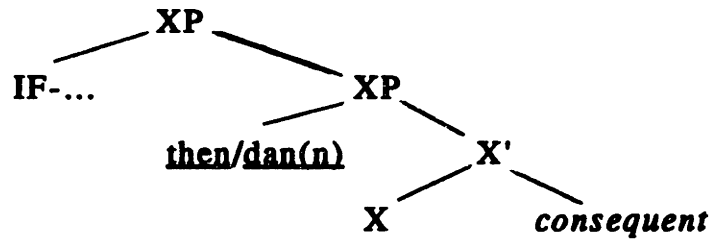

So far we have seen that the consequent in English can be a CP (since it can contain exclamatives, etc as in (1)) and that in German/Dutch it can only be an IP (see (27)). But this follows from already mentioned differences between these languages. In German/Dutch the verb must be able to leave the consequent to move to the head of the XP. If the consequent is a CP this movement is not possible. In German/Dutch the verb never leaves the CP, for whatever reason. (This may be consistent with the discussion of English, where it was argued that the clause below then is not L-marked and therefore a barrier to movement)

If all the speculative steps I have made in this section are correct, then the Dutch/German data would show that (19b) is the right representation, i.e. that then is NOT the head of the XP that contains it. Dutch and German show that this head must be free to receive the verb in V2 languages⁸.

⁸ There is one alternative that is consistent with all the aspects discussed in this section and that is the following:

The obvious question now is what the nature is of the head of XP (and therefore of the XP itself) and whether it's not *ad hoc* to postulate the existence of such an empty head. It's not clear to me what the answer should be. However, XP is not much different from other functional categories that embed sentences, i.e. from CPs, and especially from [+WH] CPs. These also contain a specialized maximal projection in the specifier and also have a head to which the verb moves in V2. I will therefore assume that XP in (19b) is a CP, but only in the sense that it is a maximal projection that embeds a sentence⁹.

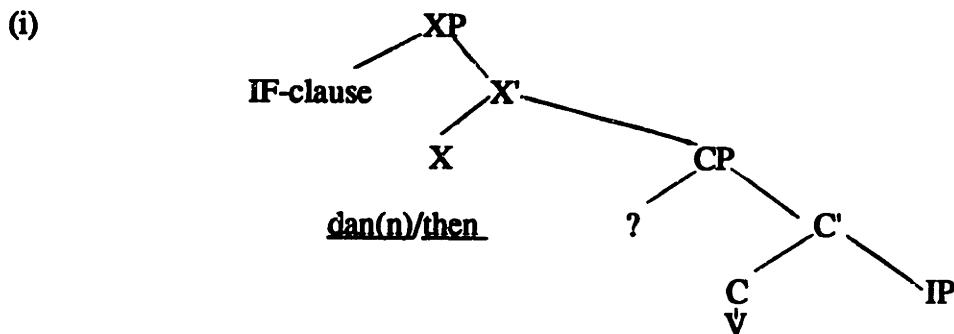

It is easy to check that (i) is consistent with everything discussed, but it leaves open the question what the element is that triggers V2, i.e. what is in the position marked '?'. This position must be filled by something (obviously phonetically null) since it causes V2 and since it blocks topicalized elements and WH-words in Dutch and German to move into it. I find this difficulty unsurpassable for now. For this reason and for the intuition mentioned in the beginning of this section that then is exhaustively dominated by a maximal projection, I will adhere to (30).

⁹ This means that the XP in (2b)/(3b) is a CP which in turn embeds the second CP. These structures should not be confused with (2a)/(3a) where the two CP segments represent adjunction.

4.2 *Some more environments where then cannot appear*

So far in this Chapter I have argued that in the absence of conditional then, the IF-clause is adjoined to the consequent which can be an IP or a CP in English. In Dutch and German the IF-clause stands in the specifier of a CP, causing the verb to raise to the head of that CP out of the consequent which is an IP. In the presence of conditional then I have argued that this is the specifier of a CP whose complement is the consequent. In English the consequent can be IP or another CP, in Dutch and German only IP. The IF-clause would be adjoined to the higher CP.

In this section I will discuss some environments where a conditional without then can appear, but a conditional containing then cannot and suggest a solution. These cases are different from the ones discussed in the previous Chapter, where the presence of then resulted in sentences that were semantically degraded. The sentences in this section that illicitly contain then do not improve when the content of the IF-clause or the consequent changes, making it obvious that it is a matter of syntactic unacceptability.

4.2.1 *Negative Contexts*

One first environment that can contain a conditional, but not a conditional with then is the complement of negative verbs. Contrast (31) and (32):

- (31) I believe that if it rains (then) the party will be cancelled
said

read

wrote

(32) I doubt that if it rains (??then) the party will be cancelled

deny

reject

am surprised

The contrast between (31) and (32) exists in other languages as well. In Basque, the verbs in (32) take the negative complementizer (Laka (1990)) and it seems that the latter can never embed orduan, the Basque then.

Contrast (33) and (34):

(33) Jonek curia egiten badu (orduan) jaia seiretan

John rain makes if-does (then) party at six

hasiko dela uste du

start COMP(AFF) thought has

'John thinks that if it rains then the party will start at six'

(34) Jonek ez du uste curia egiten badu (??orduan)

John not has though rain make if-does (??then)

jaia seiretan hasiko denik

party at six start COMP(NEG)

'John doesn't think that if it rains (??then) the party will start at six'

Laka (1990) argues that English, like Basque, has a negative complementizer, but the English one happens to be the same as the affirmative complementizer that. If she is right, the data in (32) and (34) show the same phenomenon.

Laka also argues that Spanish has a negative complementizer and that eventhough this one is, as in English, the same as its affirmative counterpart, its presence can be detected by the fact that the clause it introduces must be in the subjunctive:

- (35) a. Dudo que Maria venga/*viene
I doubt that Maria come/SUBJ/*IND
- b. Niego que Maria sepa/*sabe la verdad
I deny that Maria know/SUBJ/*IND the truth

As might be expected by now, the presence of the Spanish equivalent of then is degraded in these contexts:

- (36) Cada chico niega/duda que si su madre viene (??entonces)
Each boy denies/doubts that if his mother comes (??then)
- el partido comience a las siete
the party start/SUBJ at seven

What is it that does not permit the verbs in (32) to embed a conditional with then although they can embed a conditional without it? One

first answer (that I will replace later) comes to mind if we look at another characteristic of the verbs in (32) namely that they can license Negative Polarity Items in the clause they embed¹⁰:

- (37) I doubt that anybody came
deny
am surprised

Whatever the correct explanation is for environments that can carry an NPI, it seems that then cannot appear in them. A quick check of some other such contexts shows the same thing. First of all, NEG-raising verbs can embed an NPI:

- (38) I don't think that he has a hope in hell of winning
It isn't likely
I don't imagine

And as expected, the presence of conditional then is degraded:

- (39) I don't think that if it rains (??then) the party will be cancelled

¹⁰ In other languages (e.g. Classical Greek) the verb fear takes the negative complementizer 'mh'. This might make the prediction that English fear behaves like the verbs in (32), but it doesn't:

- (i) I fear that if it rains (then) the party will be cancelled

However, note that fear does not embed an NPI:

- (ii) *I fear that anybody came

In other words, English fear is not a negative verb at all.

It isn't likely

I don't imagine

A negated non-NEG-raising verb cannot embed an NPI and can embed conditional then:

(40) *I didn't write/say/hear that he has a hope in hell of winning

(41) I didn't write/etc that if it rains then the party will be cancelled

(For more on NEG-raising environments and why any might be better in (40), see Horn (1989))

A first possible answer to the contrast in (31) and (32) is that then cannot appear in environments where NPIs can appear, that then, in other words, is a positive polarity item¹¹. I will not explore this further here, but

¹¹ Conditional then is also degraded in embedded yes-no questions:

(i) Every boy wonders whether if his mother comes (??then) the party will be cancelled

At first this seems to support the generalization that then cannot appear where NPIs can:

(ii) I wonder whether he has a hope in hell of winning

But a closer look shows that then cannot appear in embedded questions (as in (iii,iv)) that do not permit NPIs either (as in (v)):

(iii) Every boy wonders where/how if his mother comes (*then) the party will take place EC

(iv) Every boy wonders what if his mother comes (*then) they will eat

(v) *I wonder how/where anybody fixed the car

But the ungrammaticality of then in (i), (iii) and (iv) is also related to the fact that the presence of then forms a barrier for movement from the consequent, as discussed in the beginning of this chapter. As a result, whether, how etc cannot move to the [SPEC,CP] immediately below the matrix verb. For more on NPIs in WH-questions see Lawler (1971)).

merely leave it as an option. It is not clear to me why or how then should be a positive polarity item, but more importantly, in the next section I will discuss some environments where then cannot appear and that have nothing to do with NPI licensing. I will argue that the explanation of these environments can also be expanded to the data in this section.

4.2.2 *Embedded Contexts*

In this section I will go over some more environments where the appearance of then is degraded. I will argue that that if the presence of then marks the presence of an additional CP, the degraded presence of then marks the degraded status of CP-recursion in these environments (see Vikner (1990) and references therein for CP-recursion). It will turn out that all of them are cases of CPs that are not L-marked by a verb. If this is right, it means that CP-recursion is possible in the same environments where extraction is permitted. In other words, it will appear that the following correlation holds:

(42) <u>L-marked by V</u>	<u>not L-marked by V</u>
CP-recursion	*CP-recursion
extraction	*extraction

That then is not possible inside islands is shown by the following:

(43) Inside an extraposed CP:

I regret/admit it that if it rains (??then) the party will be cancelled

(44) Inside a topicalized CP:

That if John is hungry (??then) he yells at Bill Mary knows

(45) Sentential Subject¹²:

That if John is hungry (??then) he yells at Mary bothers me

Cases of adjuncts are hard to find for the present purposes. (One case might be the following: He came walking in here like if I said a word (??then) he was going to clobber me) All adjuncts introduced by a WH-word won't do because the WH-word cannot extract from below then anyway. Adjuncts containing gerunds are also out on independent reasons: although it is possible for a gerundive adjunct to contain a conditional, as in (46):

(46) Walk to school [biting into this apple if you cross a street]

The IF-clause cannot precede the consequent:

(47) *Walk to school [if you cross a street biting into this apple]

Which, in turn, might be the result of whatever constrains topicalization in adjuncts:

¹² According to Koster (1978), sentential subjects are base-generated topics and not actual subjects. If this is so, the environments in (44) and (45) should be collapsed into one, still supporting the same point, of course.

(48) *Walk to school this apple biting

Which in turn, might be the result of a more general constraint against topicalization in non-finite clauses:

(49) *I tried this book to read

This independent ungrammaticality of (ii) is relevant in that the IF-clause must precede the consequent, for then to appear.

Another island is a relative clause, and indeed, then cannot appear inside one:

(50) I saw the man who if it rains (*then) my mother gives shelter to

But unfortunately (50) is not an argument for the present case, since its ungrammaticality can be due to the non-extractability of the relative pronoun from below then.

Conditional then is also degraded in the following environments:

(51) Inside a Complex NP:

John reported the rumour that if it rains (?then) the party will be cancelled

(52) Inside the complement of non-bridge verbs:

Every boy whispered that if his mother shows up (?then) the party will start at six

(53) WH-island (although see footnote 9):

Every boy wonders whether if his mother shows up (??then) his
mother will be ruined

We see that the presence of then patterns more or less with the possibility for object extraction. That the appearance of then patterns with object extraction and not with adjunct extraction can also be seen if we look at environments where the possibilities for object extraction diverge drastically from those of adjunct extraction. One such case is the "factive island"

(54) What did John verify that Bill has written?

(55) *Why₁ did John verify that Bill had fixed the car EC₁ ?

The appearance of then is perfectly acceptable:

(56) John verified that if a man has blond hair (then) he has blue eye

To summarize the argument so far, I am taking the possibility of embedding conditional then to indicate the possibility of CP-recursion. Judging from the above, it appears that CP-recursion is degraded inside islands, supporting the general correlation in (42). The next logical step (which I took in a previous version of the present) is to see whether other cases that have been argued to be instances of CP-recursion in English follow the pattern of conditional then. A quick check shows that embedded NEG-inversion and embedded topicalization behave more or less like then in the islands above. However, I will not include discussion of these cases here.

First of all, even the best cases of embedded NEG-inversion and embedded topicalization are marked constructions for most speakers. As David Pesetsky (p.c.) pointed out, these phenomena might be restricted by Hooper and Thompson (1973) type of effects, i.e. they would be root phenomena. Moreover the debate of whether these cases are really instances of CP-recursion (and not for example adjunction to IP, or movement to a specialized position for NEG-phrases) is too wide open at the moment to provide concrete back-ground for an already speculative proposal. In the next section I will propose a rough outline of a suggestion for why (42) might hold.

4.2.3 Towards a solution

If the discussion in the previous section is correct, it seems that embedded CP-recursion is possible to the extent that (object) extraction is possible. *Prima facie* this means that L-marking by the verb is the common factor and that whatever is a barrier for extraction is a barrier for CP-recursion. More specifically, I will suggest that an L-marked CP is in some fashion "transparent" and therefore permits the appearance of another CP below it or extraction from within it. In other words, in a structure like (57), the CP carrying that is made transparent by being L-marked by the embedding verb and a second CP can be licensed (i.e. selected) across the CP containing that:

(57)

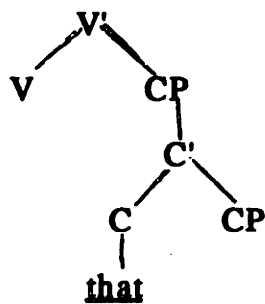

This makes the correct prediction that we cannot have three or more CPs in a row, i.e. double recursion (see Vikner and Schwartz (1991)):

(58) *

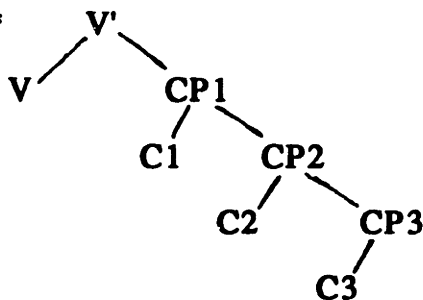

The structure in (58) is out because CP3 is not licensed. The verb makes CP1 transparent by L-marking, and CP2 can be licensed by the higher verb. But CP2 is not L-marked and therefore it is a barrier for the licensing of CP3 by the verb.

In section 4.2.1 I presented some data that showed that conditional then cannot appear below the negative complementizers of Laka (1990). At that point I had mentioned the suggestion that then is a positive polarity item. However, the considerations in this section might be able to explain those data as well, without resorting to a polarity behaviour of then. Specifically, we can propose that complementizers that are semantically contentful cannot be made transparent by L-marking. In other words, when

a CP contains a contentful complementizer, the matrix verb cannot make it transparent and license another CP over it. Following Laka (1990), I will suggest that CPs containing COMP(NEG) or COMP(WH) fall within this category. This means that recursion below such CPs is degraded:

- (59) a. ?(?) ... V [CP1(NEG) [CP2]]
 b. ?(?) ... V [CP1(WH) [CP2]] (although see fn 9 for this one)

That something like this would hold is not surprising; COMP(NEG) satisfies the selection requirements of the higher verb and these are satisfied (or checked) at LF. On the other hand licensing (of CP2) also takes place at LF. For the latter to be licensed, CP1 must be made transparent, ignored so to speak, but then the selection requirements of the negative verb will not be met yielding degraded sentences. In other words, the degraded status of sentences that have the form of (59a) or (59b) is due to the conflict that arises between the licensing conditions for CP-recursion (the COMP(NEG/WH) must not be transparent at LF) and the selection requirements of the higher verbs (the COMP(NEG/WH) must be there at LF. In the cases where that is the complementizer of the highest CP, the selection requirements of the higher verb will be satisfied by the CP containing then. This is possible since a CP containing then is equally affirmative, so to speak, as one containing that and can therefore satisfy the selection requirements of the same verb class.

REFERENCES

- Akatsuka, N. (1986). "Conditionals are Discourse-bound." In Traugott, E., ter Meulen, A., Reilly, J. and Ferguson, C. *On Conditionals*. Cambridge: Cambridge University Press, 333-351.
- van der Auwera, J. (1986). "Conditionals and Speech Acts." In Traugott, E., ter Meulen, A., Reilly, J. and Ferguson, C. *On Conditionals*. Cambridge: Cambridge University Press, 309-331.
- Bennett, J. (1982). "Even if." *Linguistics and Philosophy* 5, 403-18.
- Chomsky, N. (1981). *Lectures on Government and Binding*. Dordrecht: Foris.
- Chomsky, N. (1986). *Barriers*. The MIT Press, Cambridge, MA.
- Collins (1989). "Extraction from Conditionals" ms. MIT
- Diesing (1991). Ph.D. thesis, University Massachusetts, Amherst
- Emonds, J. (1979). "Appositive Relatives Have No Properties." *Linguistic Inquiry* 10.2, 211-43.
- Emonds, J. (1985). *A Unified Theory of Syntactic Categories*. Dordrecht: Foris Publications.
- Erteschik-Shir, N. (1981). "More on Extractability from Quasi-NPs." *Linguistic Inquiry* 12.4, 665-70, SD.
- Evans, G. (1980). "Pronouns." *Linguistic Inquiry* 11.2, 337-62.
- Farkas, D. and Sugioka, Y. (1983). "Restrictive if/when clauses." *Linguistics and Philosophy* 6, 225-258.
- Fauconnier, G. (1975). "Polarity and the Scale Principle." *CLS* 11, 188-199.
- Geis, M. and Lycan (1989). *A treatise on Conditionals*, typescript
- Haegeman, L. and Wekker, H. (1984). "The Syntax and Interpretation of Futurate Conditionals in English." *Journal of Linguistics* 7, 263-281.
- Heim, (1982). *The Semantics of Definite and Indefinite Noun Phrases Ph.D. Dissertation, University Massachusetts, Amherst*
- Heim, (1989). "Lecture Notes" ms. MIT
- Hooper, J. and Thompson, S. (1973). "On the Applicability of Root Transformations." *Linguistic Inquiry* 4.4, 465-497.
- Horn (1969). "A Presuppositional Analysis of *Only* and *Even*." In *Papers from the Fifth Regional Meeting of the Chicago Linguistic Society*. Chicago: University of Chicago, Department of Linguistics.

- Iatridou, S. (1990). "Clitics and Island Effects" ms. MIT
- Iatridou, S (in preparation). "Negative Polarity Items and Conditionals"
- Kratzer, A. (1986). "Conditionals." In A.M. Farley, P.T. Farley and K.E. McCulloch eds, *Papers from the Parasession on Pragmatics and Grammatical Theory at the Twenty Second Regional Meeting of the Chicago Linguistic Society*. Chicago: Chicago Linguistic Society.
- Laka, I. (1990). *Negation in Syntax: On the Nature of Functional Categories and Projections*. Ph.D. Thesis, MIT.
- Larson, R. (1985). *Restrictive Modification: Relative Clauses and Adverbs*. Ph.D. Thesis, U. of Wisconsin at Madison.
- Lasnik, H. (1986). "On Accessibility." *Linguistic Inquiry* 17.1, 126-129, RR.
- Lasnik, H. and Saito (1991). *Move a* MIT. Press
- Levinson, (1983). *Pragmatics* Cambridge University Press
- Lewis, (1975). "Adverbs of Quantification"
- Linebarger, (1980). *The Grammar of Negative Polarity* Ph.D. Dissertation MIT
- May, R. (1985). *Logical Form: Its Structure and Derivation*. MIT Press
- Pesetsky, D. "Language Particular Processes and the Earliness Principle" ms. MIT
- Rizzi, L. (1990). *Relativized Minimality* MIT Press, Cambridge
- Ross, (1970). *Constraints on Variable in Syntax* Ph.D. dissertation MIT
- Safir, K. (1985). *Syntactic Chains* Cambridge University Press
- Safir, K. (1986). "Relative Clauses in a Theory of Binding and Levels." *Linguistic Inquiry* 17.4, 663-689.
- Stalnaker, R. (1970). "Probability and Conditionals." *Philosophy of Science* 37, 64-80. Reprinted in Harper, W., Stalnaker, R. and Pearce, G. eds. (1981). *Ifs*. Dordrecht.
- Stowell, T. (1990). *Origins of Phrase Structure* Ph.D. dissertation MIT
- Stuurman, F. (1983). "Appositives and X-Bar Theory." *Linguistic Inquiry* 14.4, 736-744, SD.